

(No Model.)

F. A. BAILEY.  
ROLLER SKATE.

No. 301,041.

Patented June 24, 1884.

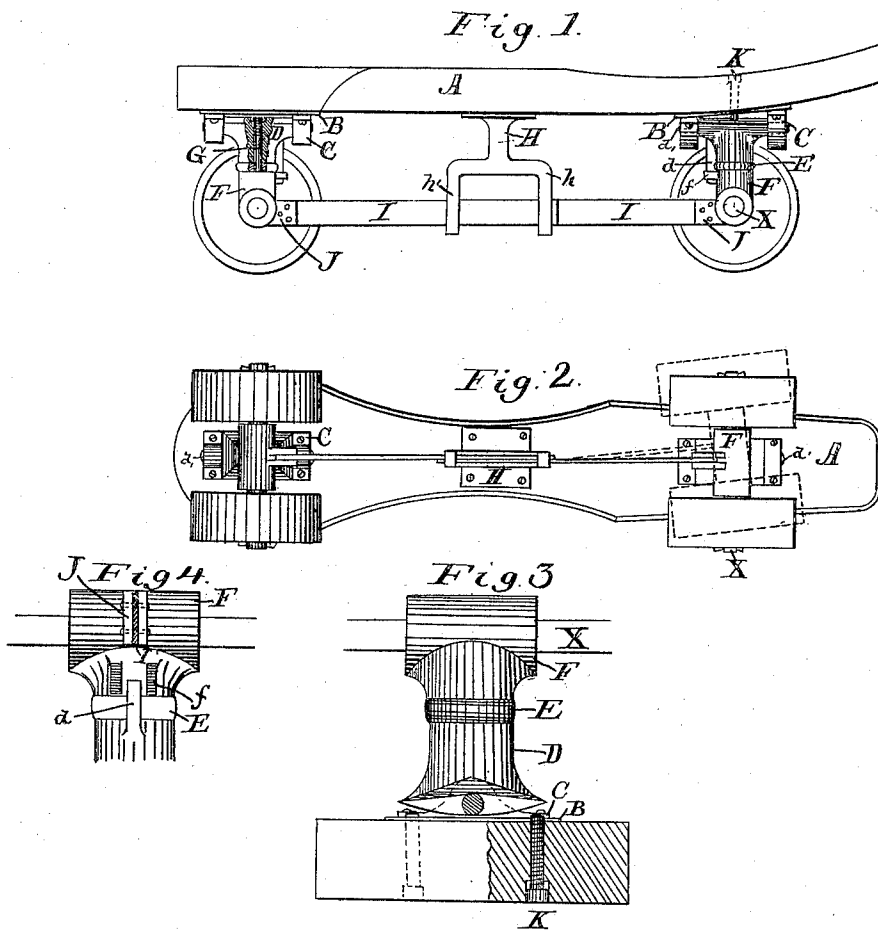

Witnesses:  
C. E. Sturtevant.  
E. W. Roberts.

Inventor:  
Fred. A. Bailey  
by S. M. Bates  
his atty.

# UNITED STATES PATENT OFFICE.

FRED A. BAILEY, OF OAKLAND, MAINE.

## ROLLER-SKATE.

SPECIFICATION forming part of Letters Patent No. 301,041, dated June 24, 1884.

Application filed April 16, 1884. (No model.)

*To all whom it may concern:*

Be it known that I, FRED A. BAILEY, a citizen of the United States, residing at Oakland, in the county of Kennebec and State of Maine, have invented certain new and useful Improvements in Roller-Skates, of which the following is a specification, reference being had therein to the accompanying drawings.

My invention relates to roller-skates; and the object of my invention is to do away with rubber springs and to substitute therefor straight longitudinal steel springs of such form that they will be subjected to little wear and may easily be made with different degrees of stiffness. I accomplish this result by means of the arrangements shown in the accompanying drawings, in which—

Figure 1 shows side elevation of skate. Fig. 2 is a bottom view of same. Fig. 3 is a view of rear truck, looking to the front. Fig. 4 is a front view of same.

A is the foot-plate of the skate, attached to the under side of which are the forward and rear trucks in their usual positions. These trucks are alike in their construction and operation.

B is a plate, on each end of which are the journal-boxes C, through which screws pass, securing the plate B to the wood. The hanger D is hung by journals *d d'* to the boxes C C.

F is the hub through which pass the axles X X, which contain the rolls. The hub F is joined to the hanger D by the rod G, with a nut on its upper side. The rod G forms an axis about which the hub F is free to move.

E is a rubber washer placed between the hub F and hanger D. Two spurs, *ff*, project from the upper part of the hub F, while a stop, *d*, is cast in the hanger D, and plays between the spurs *f*. Half-way between the trucks is the bifurcated standard H, having the two arms *h* and *h'*. Through slots in these arms pass two straight springs, I I. One end of each spring is secured to one of the trucks, while the opposite ends overlap each other, both passing through the arms *h* and *h'*, as described. The screws K K pass through the foot-plate of the skate and project underneath on each side of the hanger D in such a manner that when the hangers turn in their bear-

ings the motion of the hangers will be stopped by the ends of the screws K K.

Having thus described the construction of my skate, I now proceed to explain its mode of operation. When one side of the skate is pressed, the lower end of the truck is thrown one side of the center of the skate, as shown by the dotted lines in Fig. 2. The motion takes place about the bearings *d d'* of the hanger D. As the rolls are thus thrown over the hub F is made to swing around at an angle with the center line of the skate, turning on the axis G by the action of the spring I, one end of which remains fast to the standard H, while the other end swings with the truck. As soon as the truck is moved to one side the tension of the spring I begins to be felt, and as soon as pressure on the skate is removed the spring I brings the truck again into line with the center of the skate. When it is desired to limit the motion of the trucks, the screws K are raised or lowered, and are thus made to stop the hangers at any desired inclination. The stop *d*, playing between the spurs *ff*, serves to prevent the hub F from turning beyond a fixed point, and so breaking the spring I. The springs I may be attached to the hub F with bolts and nuts, which may be readily removed, and the springs thus changed.

It is designed to manufacture springs of varying stiffness, so that different tastes may be suited in this respect.

Instead of two overlapping springs, I may have one horizontal spring, each end secured to one of the hubs, and the middle secured by the standard.

In place of one bifurcated standard, I may use two single standards, in which case, by moving each from or toward the truck, I can govern the sharpness of the curvature of the truck when pressed to one side.

It is evident that by the use of long straight springs I am able to line the trucks more carefully, and the springs themselves act with more delicacy and certainty than by the use of rubber springs.

I claim—

1. In a roller-skate, the combination of the hanger D and hub F, having between them

the rubber washer E, with the horizontal overlapping springs I I and the bifurcated standard H, substantially as shown and described.

2. In a roller-skate, the combination of the  
5 standard H, springs I, hub F, and hanger D, with the regulating-screws K K, substantially as shown and described.

In testimony whereof I affix my signature in presence of two witnesses.

FRED A. BAILEY.

Witnesses:

S. W. BATES,

C. E. STURTEVANT.