

(19) World Intellectual Property Organization
International Bureau



(43) International Publication Date
4 August 2011 (04.08.2011)

PCT

(10) International Publication Number
WO 2011/094099 A1

- (51) **International Patent Classification:**
B60H 1/00 (2006.01) F25B 27/00 (2006.01)
B60H 1/32 (2006.01)
- (21) **International Application Number:**
PCT/US2011/021694
- (22) **International Filing Date:**
19 January 2011 (19.01.2011)
- (25) **Filing Language:** English
- (26) **Publication Language:** English
- (30) **Priority Data:**
61/299,827 29 January 2010 (29.01.2010) US
- (71) **Applicant (for all designated States except US):** CARRIER CORPORATION [US/US]; One Carrier Place, Farmington, CT 06034 (US).
- (72) **Inventors; and**
- (75) **Inventors/Applicants (for US only):** BLASKO, Vladimir [US/US]; 8 Anvil Drive, Avon, CT 06001 (US). BENDAPUDI, Satyam [US/US]; 39 Buckland Street, Apt. 9231, Manchester, CT 06040 (US). OGGIANU, Stella, M. [US/US]; 39 Buckland Street, Apt. 1031-1, Manchester, CT 06042 (US).
- (74) **Agent:** HABELT, William, W.; 250 South Clinton Street, Suite 300, Syracuse, NY 13202 (US).

- (81) **Designated States (unless otherwise indicated, for every kind of national protection available):** AE, AG, AL, AM, AO, AT, AU, AZ, BA, BB, BG, BH, BR, BW, BY, BZ, CA, CH, CL, CN, CO, CR, CU, CZ, DE, DK, DM, DO, DZ, EC, EE, EG, ES, FI, GB, GD, GE, GH, GM, GT, HN, HR, HU, ID, IL, IN, IS, JP, KE, KG, KM, KN, KP, KR, KZ, LA, LC, LK, LR, LS, LT, LU, LY, MA, MD, ME, MG, MK, MN, MW, MX, MY, MZ, NA, NG, NI, NO, NZ, OM, PE, PG, PH, PL, PT, RO, RS, RU, SC, SD, SE, SG, SK, SL, SM, ST, SV, SY, TH, TJ, TM, TN, TR, TT, TZ, UA, UG, US, UZ, VC, VN, ZA, ZM, ZW.
- (84) **Designated States (unless otherwise indicated, for every kind of regional protection available):** ARIPO (BW, GH, GM, KE, LR, LS, MW, MZ, NA, SD, SL, SZ, TZ, UG, ZM, ZW), Eurasian (AM, AZ, BY, KG, KZ, MD, RU, TJ, TM), European (AL, AT, BE, BG, CH, CY, CZ, DE, DK, EE, ES, FI, FR, GB, GR, HR, HU, IE, IS, IT, LT, LU, LV, MC, MK, MT, NL, NO, PL, PT, RO, RS, SE, SI, SK, SM, TR), OAPI (BF, BJ, CF, CG, CI, CM, GA, GN, GQ, GW, ML, MR, NE, SN, TD, TG).

Published:

— with international search report (Art. 21(3))

(54) **Title:** SOLAR POWER ASSISTED TRANSPORT REFRIGERATION SYSTEMS, TRANSPORT REFRIGERATION UNITS AND METHODS FOR SAME

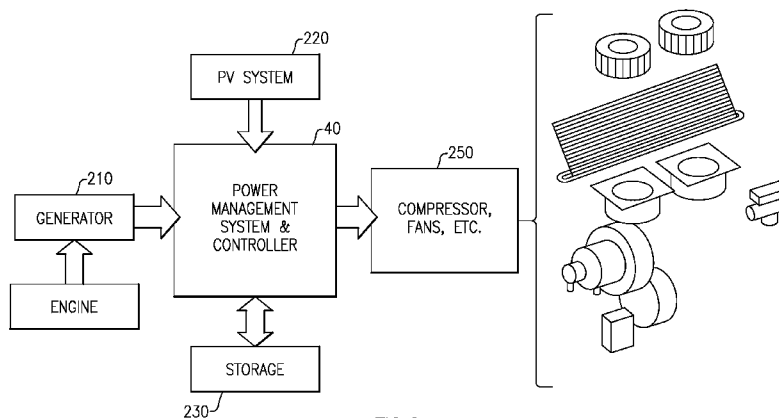

FIG.2

(57) **Abstract:** A transport refrigeration system, comprising: a compressor (22); a first electric motor (26) that provides a motive force to the compressor; at least one fan (52, 56, 82, 84, 86); a second electric fan motor (54, 56, 88, 90, 92) that provides a motive force to the fan; a solar PV electrical power source (220); an electric energy power source (230); a engine driven generator electrical power source (210); and a power management controller (40) coupled to route power selectively and concurrently from two of the electrical power sources (210, 220, 230) to provide electrical power to the first motor (26) and the second motor (54, 56, 88, 90, 92).

WO 2011/094099 A1

SOLAR POWER ASSISTED TRANSPORT REFRIGERATION SYSTEMS, TRANSPORT REFRIGERATION UNITS AND METHODS FOR SAME

CROSS-REFERENCE TO RELATED APPLICATION

[0001] This application claims priority to U.S. Provisional Patent Application Serial No. 61/299,827 entitled "Solar Power Assisted Transport Refrigeration Systems, Transport Refrigeration Units and Methods for Same" filed on January 29, 2010. The content of this application is incorporated herein by reference in its entirety.

FIELD OF THE INVENTION

[0002] This invention relates generally to the field of transport refrigeration systems and methods of operating the same, and more particularly to the integration of disparate power sources or energy storage device.

BACKGROUND OF THE INVENTION

[0003] Transport refrigeration systems such as containers, truck, trailer, and bus, depend on fossil-fuel driven prime movers to provide the electrical energy needed to run the components of the transport refrigeration system. This fuel consumption is over and above what is required to operate the vehicle and becomes a significant added cost of operation. Solar panels have been used to support truck refrigeration. However, these related art systems manually switch between a fuel driven engine and the solar panel to separately provide the energy to the transport refrigeration system and required extra container insulation and downsizing of the original equipment to which the solar power is being applied to, which leads to either a performance penalty or a higher initial cost due to redesign or both.

SUMMARY OF THE INVENTION

[0004] Perishable items must be maintained within a temperature range to reduce or prevent, depending on the items, spoilage, or conversely damage from freezing during transport. A transport refrigeration unit is used to maintain proper conditions within a transport cargo space. The transport refrigeration unit can regulate conditioned air delivery by the transport refrigeration unit to a container or the transport cargo space. The transport refrigeration unit can be under the direction of a controller that can operate a transport refrigeration system including a power management capability.

[0005] In view of the background, one aspect of the application is to provide a novel power system configuration, management, and methods for same for a transport refrigeration system.

[0006] In view of the background, it is an object of the application to provide a transport refrigeration system, transport refrigeration unit, and methods of operating same that can ensure real-time allocation from integrated solar power into the refrigeration system, both as a function of load or demand, and/or solar energy availability.

[0007] Embodiments of power management configurations and control architectures can integrate solar power into the electrical system of a transport refrigeration system.

[0008] Embodiments of power management systems and methods can integrate solar power into the electrical system of a transport refrigeration system to ensure real-time allocation of energy from disparate power sources into the refrigeration system, both as a function of load or demand, as well as of solar energy availability.

[0009] Embodiments of power management system can integrate solar power into the electrical system of a transport refrigeration system with no loss of functionality to the container during maintenance or shipping and handling of the container.

[00010] Embodiments of power management system can combine solar power into the electrical system of a transport refrigeration system and use peak power tracking to integrate use of the solar generated power.

[00011] In one embodiment, solar fabrics are used and attached to surfaces of the container or trailer body to allow removal and re-installation depending on operational needs (*e.g.*, in the field).

[00012] One embodiment according to the application can include a control module for a transport refrigeration system for controlling an improved all-electric transport refrigeration system that receives its compressor drive motor power and all other electrical power concurrently from a combination of a solar photovoltaic (PV) system and fossil fuel driven prime movers.

[00013] One embodiment of a transport refrigeration system according to the application can include a power control module to control concurrent supply of electrical energy from a solar PV system, an engine driven generator, and batteries.

[00014] In an aspect of the invention, a transport refrigeration system can include a compressor; a first electric motor that provides a motive force to the compressor; at least one fan; a second electric fan motor that provides a motive force to the fan; a solar PV electrical power source; a battery electrical power source; an engine driven generator electrical power source; and a power management controller coupled to route power selectively and concurrently from two of the electrical power sources to provide electrical power to the first motor and the second motor.

BRIEF DESCRIPTION OF THE DRAWINGS

[00015] Novel features that are characteristic of exemplary embodiments of the invention are set forth with particularity in the claims. Embodiments of the invention itself may be best understood, with respect to its organization and method of operation, with reference to the following description taken in connection with the accompanying drawings in which:

[00016] FIG. 1 is diagram that schematically illustrates an exemplary transport refrigeration system having a compressor with an integrated electric drive motor powered by an electrical power system designed according to embodiments of the application;

[00017] FIG. 2 is diagram that illustrates a power control apparatus for a transport refrigeration system according to embodiments of the application;

[00018] FIG. 3 is a diagram that illustrates an exemplary embodiment of a power management system for a transport refrigeration system according to the application;

[00019] FIG. 4 is a diagram that illustrates another exemplary embodiment of a power management system for a transport refrigeration system according to the application;

[00020] FIG. 5 is a diagram that illustrates another exemplary embodiment of a power management system for a transport refrigeration system according to the application;

[00021] FIG. 6 is a diagram that shows an exemplary power output characteristics of solar PV films;

[00022] FIG. 7 is a diagram that illustrates an exemplary embodiment of a solar film mounting platform affixed to a container according to the application; and

[00023] FIG. 8 is a diagram that illustrates another exemplary embodiment of a power management system for a transport refrigeration system according to the application.

DETAILED DESCRIPTION OF EXEMPLARY EMBODIMENTS

[00024] Reference will now be made in detail to exemplary embodiments of the application, examples of which are illustrated in the accompanying drawings. Whenever possible, the same reference numerals will be used throughout the drawings to refer to the same or like parts.

[00025] Transportation refrigeration systems can be offered in diverse architectures, for example, for use with trucks, truck-trailers, and containers. Refrigerant vapor compression systems used in connection with transport refrigeration systems are generally subject to more stringent operating conditions than in air conditioning or commercial refrigeration applications due to the wide range of operating load conditions and the wide range of outdoor ambient conditions over which the refrigerant vapor compression system must operate to maintain product within the cargo space at a desired temperature. The desired temperature at which the cargo needs to be controlled can also vary over a wide range depending on the nature of cargo to be preserved. The refrigerant vapor compression system must not only have sufficient capacity to rapidly pull down the temperature of product loaded into the cargo space at ambient temperature, but also operate efficiently at low load when maintaining a stable product temperature during transport. Additionally, transport refrigerant vapor compression systems are subject to cycling between an operating mode and standstill mode, *e.g.*, an idle state.

[00026] Fig. 1 is a diagram that shows an exemplary embodiment of a transport refrigeration system. Referring to FIG. 1, a trailer refrigeration system 20 is schematically illustrated with a compressor 22. A compressing mechanism 24, an electric compressor motor 26 and an interconnecting drive shaft 28 are all sealed within a common housing of the compressor 22. In one example, the compressor 22 is a variant of a 06D compressor manufactured by Carrier Corporation.

[00027] A power management system 40 that is capable of fully powering the internal electric motor 26 of the compressor preferably also provides power to satisfy the electrical requirements of other portions of the system 20 as will be explained. For example, the power management system 40 can integrate a plurality of disparate power sources into the system 20. In one embodiment, the power sources can include a solar PV system, batteries, and fuel driven prime movers (*e.g.*, diesel engines). A controller 42, which may be a commercially available microprocessor, can be used to control power usage in the system 20 or incorporated into the power management system 40.

[00028] Operations of the refrigeration system 20 can be described starting at the compressor 22, where the refrigerant enters the compressor and is compressed to a higher temperature and pressure. Refrigerant gas then moves into the air-cooled condenser 44. Air flowing across a group of condenser coil fins and tubes 46 can cool the gas to its saturation temperature. The air flow across the condenser can be energized by a condenser fan assembly 50 having two fans. The illustrated example includes fan 52, electrical condenser fan motor 54 and fan 56 having electrical motor 58. The controller 42 can regulate power supply to the fan motors 54, 58.

[00029] By removing latent heat, the gas can condense to a high pressure/high temperature liquid and flow to a receiver 60 that provides storage for excess liquid refrigerant during low temperature operation. From the receiver 60, the liquid refrigerant can pass through a subcooler heat exchanger 64, through a filter dryer 66 that can keep the refrigerant cool and dry, then to a heat exchanger 68 that can increase the refrigerant subcooling, and then pass to a thermostatic expansion valve 70.

[00030] As the liquid refrigerant passes through the expansion valve 70, some of it vaporizes into a gas. Return air from the refrigerated space flows over the heat transfer surface of an evaporator 72. As refrigerant flows through tubes 74 in the evaporator 72, the remaining liquid refrigerant absorbs heat from the return air, and in so doing, can be vaporized. The air flow across the evaporator can be energized by an evaporator fan assembly 80. The illustrated example includes three fans 82, 84 and 86 that are respectively powered by electric fan motors 88, 90, and 92. The fan motors 88, 90 and 92 can receive their electrical power from the power management system 40. The controller 42 can control the consumption of power and operations of the fan motors 88, 90, 92 of the evaporator fan assembly.

[00031] Refrigerant vapor can flow through a suction modulation valve 100 back to the compressor 22 and integral drive motor 26. A thermostatic expansion valve bulb or sensor can be located on the evaporator outlet tube. The bulb can control the thermostatic expansion valve 70, to control refrigerant super-heating at the evaporator outlet tubing.

[00032] Exemplary embodiments of transport refrigeration systems integrate three energy systems: the generator for pull-down and off-solar operation, the solar films, and the battery system. Each of these energy sources has a distinct set of power characteristics that need to be conditioned before being fed between each other, or to the loads. The generator puts out 3-phase AC, while the solar PV and the battery produce DC power. The power management system 40 can actively manage these energy sources to ensure performance, reliability, availability and/or energy efficiency. In one embodiment, inclusion of a storage system, which can be selected using a trade-off between weight, cost, and size, can provide dual functionality of capturing solar energy in excess of load, as well as a source for starting up the generator's engine.

[00033] Exemplary connections of the power management system 40 are shown in FIG. 2. As shown in FIG. 2, the power management system 40 can transfer and receive power from generator 210, receive power from solar PV system 220, transfer and receive power from storage 230 (*e.g.*, battery). The power management system 40 can transmit and receive control signals to and from the generator 210, the solar PV system 220, and the electrical energy storage 230.

[00034] The power management system 40 can controllably provide electrical energy for a dynamic load 250 of the transport refrigeration unit. The load 250 can include the AC driven and DC driven components. The power management system 40 can supply the power needed for the electrical motors associated with the compressor 22, condenser fan assembly 50, and the evaporator fan assembly 80.

[00035] Exemplary power electronic architectures for the embodiments of power management systems are shown in FIGS. 3-5. An exemplary embodiment of a power controller is shown in FIG. 3. As shown in FIG. 3, power management system and controller 340 is electrically coupled to engine driven generator 310, solar PV system 320 and electric energy source 330 (*e.g.*, rechargeable battery, capacitor, super capacitor).

[00036] The power management system and controller 340 can connect the generator 310 to provide power to the components of the transport refrigeration unit. The generator 310, compressor 352 (*e.g.*, drive motor), battery charger 344, and also optional additional electrically powered components 356 are connected to an AC power bus. Exemplary additional components 356 can include sensors (*e.g.*, temperature sensors), valves (*e.g.*, expansion valve, solenoid valves), and the like. Driven by controller 342, the generator 310 can supply AC power to battery charger 344 and AC electricity to the compressor. Controller 346 can be connected to a DC power bus between the solar PV system 320 and DC powered fans 354 and between the electric energy source 330 and the DC powered fans 354. In one embodiment, the DC power bus can operate between 24 volts DC and 48 volts DC. As shown in FIG. 3A, the DC/DC converter can manage the energy flows from solar power and the electric energy source to the DC fans 354. The power management system and controller 340 has a low cost implementation that can integrate the solar power for selected components of the transport refrigeration unit (*e.g.*, the DC fans 354) through a DC bus.

[00037] An exemplary embodiment of a power controller is shown in FIG. 4. As shown in FIG. 4, power management system and controller 440 is electrically coupled to generator 310, solar PV system 320 and electric energy source 330 (*e.g.*, rechargeable battery).

[00038] The power management system and controller 440 can connect the generator 310, the solar PV system 320, and electric energy source 330 to an AC power bus coupled to components of the transport refrigeration unit. The generator 310 is connected to the compressor 24, AC fans and also optional additional electrically powered components 356. Driven by controller 442, the generator 310 can supply AC power to single phase loads (*e.g.*, fans) and three phase loads (*e.g.*, the compressor 24). Controller 444 is connected between the solar PV system 320 and load (single phase load) representing the transport refrigeration unit. Controller 446 is connected between the electric energy source 330 and the single phase load. The controllers 444, 446 can include DC/AC converters to convert the DC to AC to enable the fans to retain AC motors and can synchronize the power and levels between the three sources. For example, additional electrically powered components 356 can include additional single phase AC load, a three phase AC load, or any DC load (*e.g.*, additional fans/compressor, additional heating system).

[00039] As shown in FIG. 4, the power management system and controller 440 requires little change in the load hardware. The power management system and controller 440 retains

the AC motors for the fans, and enables single-phase and 3-phase loads as needed. The power management system and controller 440 can perform field matching and power matching between power supplied by different sources before it can be provided to the transport refrigeration unit. Such conditioning can be performed by hardware (*e.g.*, inverters) and/or software (*e.g.* using a processor or controller). However, the power management system and controller 440 provides AC power only from the transport refrigeration unit side, in contrast to the two different power modes as shown in FIG. 3.

[00040] An exemplary embodiment of a power controller is shown in FIG. 5. As shown in FIG. 5, power management system and controller 540 is electrically coupled to generator 310, solar PV system 320 and electric energy source 330 (*e.g.*, battery).

[00041] The power management system and controller 540 can selectively connect between each of the generator 310, the solar PV system 320, and the electric energy source 330 and can provide a connection to the load represented by the transport refrigeration system 200 (*e.g.*, the single phase load and three phase load). Driven by controller 540, the three power sources can supply AC power to single phase loads (*e.g.*, fans) and three phase loads (*e.g.*, the compressor 24). The power management system and controller 540 can have an integrated power system with optimized controllers that can be designed for additional functionality. The power management system and controller 540 control the engine-generator starter and can control variable speed compressors and fans.

[00042] In one embodiment, power management system and controller 540 can include a dedicated power unit to include a single converter to integrate connected energy sources for power management. The converter can interface directly with all the generator 310, the solar PV system 320, and the electric energy source 330 to output single three phase AC output. In this embodiment, the power management system and controller 540 can replace the plurality of converters (*e.g.*, DC/DC converters, DC/AC converters) previously needed, which can be cost effective and can reduce complexity of the control required for multiple converters. Further, the dedicated power unit can ensure the voltage at output on R, S, T has fixed voltage and fixed frequency regardless of variation of variation of voltage and frequency at generator. Accordingly, control of generator can be reduced and/or greater engine variation can be accepted to reduce overall consumption. Also, the engine could be driven at greater efficiency levels less dependent of fluctuations of the load.

[00043] In one embodiment, power management system and controller 540 can include a power transfer panel to transfer loads (*e.g.*, automatically) between the additional power sources (320 and 330) and the generator 310 (engine). The transfer panel for the power management system and controller 540 can monitor the solar PV set power and/or the electric energy source/battery set available energy. When the solar PV set power and/or the battery set state of charge is unsatisfactory (*e.g.*, under-voltage monitoring on each power source, low battery state of charge, power source failure), the power management system and controller 540 can switch or transfer the load to the generator (*e.g.*, can initiate start-up of the engine-generator). The transfer panel for the power management system and controller 540 can immediately sense when the solar PV set power and/or the electric energy source/battery set power is restored to can switch or transfer the load from the generator. Exemplary load transfers can include partial or complete. The load transfer can include selected components only (*e.g.*, fans). The load transfer can include single phase load transfer.

[00044] Table 1 compares the three embodiments for the power management system and controller 340, 440, 540.

Table 1: Comparison of Exemplary Architectures

Concept Architecture	Compressor		Fans	Extras
	Power	Solar Driven		
FIG. 3	AC	N	DC	N
FIG. 4	AC	N	AC	N
FIG. 5	AC	Y	AC	Y

[00045] Exemplary engines used for generators can be operated inefficiently because the desired power output is constantly changing in response to needs of the transport refrigeration unit (*e.g.*, to maintain a constant temperature in a corresponding). In one embodiment, the power management system can size the incorporated storage system like a battery set so that the engine can operate (*e.g.*, always) at a steady condition or at least a much more predictable condition and/or reduce an amount of bouncing around or changing speeds/power level. Accordingly, the power management system can control whenever there is excess power it goes to store the excess electric energy for example in storage such as a battery and likewise, when there is insufficient power, the deficit can be drawn from storage or solar PV system. In one embodiment, the engine can be operated at a constant speed or peak efficiency point or RPM.

[00046] Embodiments of transport refrigeration systems and methods for same can integrate and provide concurrent use of the solar energy and/or the solar PV system 220. Electrical characteristics of solar PV films have power output that increases linearly with voltage up to a peak 610 as shown in FIG. 6. Beyond the peak 610, the output can drop rapidly. To increase utilization of the solar energy, and therefore increase or maximize fuel savings to the transport refrigeration systems, the power management controller needs to operate the solar PV system 220 at (or near and preferably before) the peak power point. Accordingly, in one embodiment, the power management system 40 (*e.g.*, 540) can implement a maximum point tracking (*e.g.*, solar power peak tracking) for the solar PV system to adjust the current and/or electrical energy drawn from the solar film to cause the solar PV system 220 to follow peak output under varying irradiance and load conditions.

[00047] In situations when portions of the solar film are obscured (for example, under spotty clouds) or are otherwise compromised, the solar energy usage can still be increased or maximized by incorporating a health-monitoring system in the power management controller. For example, the power management system 40 can be designed to monitor the health and output of the solar films, and dynamically adjust the power drawn from the healthiest and/or highest output sections of the solar film to be different from the power drawn from damaged (permanent modification) or obscured (temporary modification) portions of the solar film. In one embodiment, the solar film can have modular unit construction to remove (*e.g.*, electrically isolate) damaged portions from the solar PV system.

[00048] In one embodiment, the power management system and controller can use the storage to primarily drive the control priority. For example, the power management system and controller 540 can prioritize electrical energy sources or storage (*e.g.*, battery usage and/or lifetime), over control for the solar PV system or generator. In one embodiment, operations for battery lifetime and overall reduced power consumption can provide control requirements for the power management system and controller. Battery lifetime can be increased differently by type of battery, but an exemplary battery can have increased of maximum lifetime with charge levels between 40-60% or 25-75% (*e.g.*, NiMH), which can provide secondary control requirements for the generator and solar PV system that can be implemented using exemplary converters. One exemplary energy management control can always keep selected battery control conditions (*e.g.*, when to charge and withdraw electrical energy), then receive solar PV power at the controlled or maximum amount that does not

conflict with the battery condition, then drive generator to achieve reduced overall power consumption over a selected time period. In one embodiment, the solar PV system is driven at less than maximum point tracking to provide acceptable battery control. In addition, power and energy management control can vary dependent on relative proportions of energy supplied from different energy sources (*e.g.*, storage, solar PV system, or generator).

[00049] In one embodiment, the power management system and controller can determine the selected power flowing from and to the energy storage system, from the engine and/or from the solar PV based on respective forecasts and estimates for solar PV power and refrigeration consumption. The power set-points for each of the components will be based on energy and power management strategies that will address or prioritize either life-time of the individual equipment or the full system, prioritize on energy efficiency, and/or prioritize on environmental constraints. For example, a load requirement for a transport refrigeration unit can be forecast (*e.g.*, indefinitely) using for example ambient conditions, the cargo itself, and transport refrigeration unit components. The solar PV system capability can be forecast for a relatively short time (*e.g.*, 6 hours, 12 hours, 24 hours), however, with less certainty. Embodiments for energy management control using the power management system and controller can selectively control the amount of energy from each of the storage (*e.g.*, battery), the solar PV system, or the generator using the forecast information. Further, the energy management control can prioritize overall energy consumption by different modes of use such as but not limited to environmental friendly (*e.g.*, prioritize renewable energy sources), overall power consumption (*e.g.*, operate generator at peak efficiency), field conditions (*e.g.*, utilize the solar PV system or battery to reduce noise near a hazardous location), operation convenience (*e.g.*, the generator to load and the solar PV system to charge battery, or the generator to charge battery and the solar PV system to the load).

[00050] Mechanical integration of the solar PV system 320 can be achieved without significant modification to the trailer. The form profile of the trailer needs to be maintained low to avoid damage from air-flow when the vehicle is in motion. Trailers are designed to be handled by cranes, and may be stacked on rail yards. Often, maintenance personnel need to walk on the roofs as part of hitching and unhitching to cranes. Embodiments of the application incorporate removable and re-installable solar PV systems with no loss of functionality of the container during shipping, handling and/or maintenance. As shown in FIG. 7, a frame 710 in one embodiment can allow for installation of a solar film that will

shield the container from solar radiation (a physical barrier), and allow removal for shipping and handling, allow access for maintenance while achieving a low profile. For example, the frame 710 can be mechanically fastened to container corners using existing features.

Alternatively, the solar PV film can be mounted to a backing sheet for attachment or removal from the container without modification to the container itself. In one embodiment, the solar PV system can be additionally selectively mounted on an additional side of the container or trailer.

[00051] FIG. 8 is a diagram that illustrates another exemplary embodiment of a power management system for a transport refrigeration system according to the application. As shown in FIG. 8, power management system and controller 840 can operate to directly supply power from the solar PV system to the transport refrigeration unit 850. The power management system and controller 840 can adapt power voltage, frequency, and phases (*e.g.*, converters) to levels used by the existing transport refrigeration unit 850. Alternatively, energy storage 860 such as batteries can be optionally included.

[00052] Embodiments of the transport refrigeration systems and methods can increase or maximize the use of solar energy during the times that it is available. In one embodiment, the solar PV system is a high efficiency solar PV system and power management system 40 constantly monitors and dynamically draws the power from the solar PV system to achieve efficient operations of the solar PV system (*e.g.*, over an operational interval or instantaneously). To maintain the critical functional requirements of the refrigeration system, the power management system 40 also needs to handle the dynamics of energy supply and demand in real-time.

[00053] In one embodiment, a solar-assisted refrigeration system is provided where the solar availability (*e.g.*, like the energy availability from a falling elevator) is a random variable that needs to be dynamically adapted to by the power management controller.

[00054] Embodiments of an all electric transportation refrigeration system can reduce mechanical hardware such as the stand-by motor, clutches, belts, and pulleys, which can be replaced by cheaper, efficient, and more robust electrical hardware.

[00055] The all-electric system can improve performance by enabling better control algorithms that can seamlessly transition between available energy sources as available. Since solar energy availability can fluctuate, it is important to have a control system that can

seamlessly transition between solar power, additional energy sources and the generator to ensure that the refrigeration system power needs are always met.

[00056] Embodiments of the transport refrigeration system have various advantages. The use of thin film solar PV enables increased or maximized coverage over the trailer surfaces; the solar PV is removable and re-installable on the trailer, *e.g.*, no loss of functionality to the trailer; solar utilization is increased or maximized by a peak-power tracking in the controller to follow the power profile of the PV system; overall system controllability is improved over the conventional direct drive system since mechanical actuators are replaced with electrical and electronic systems; fuel-savings are increased or maximized through power management system that seamlessly transitions between available energy sources as required by the load; hardware reduction is achieved by eliminating the stand-by motor and associated mechanical drive components, and reliability is increased by eliminating two-thirds of the serviceable mechanical components found in conventional systems, such as idler pulleys, vibrasorbers, most belts, fan shafts, the compressor shaft seal and clutch.

[00057] Embodiments of the transport refrigeration system (hybrid-electric) enable it to have power from the engine and solar PV cells available for use in the various parts of the refrigeration unit at any given time. In addition, the controller can intelligently manage the storage system and can also be used to start-up the diesel generator when needed. Embodiments of the transport refrigeration system can incorporate such algorithmic features to use the available solar energy, all of which are enabled by the all-electric system.

[00058] It should be understood that although the present application has been described as useful in transport refrigeration systems, those of skill in the art will readily understand and appreciate that the present invention may also be useful, and provide many benefits, in other types of refrigeration systems.

[00059] Exemplary containers and transport refrigeration systems described herein may be towed by a semi-truck for road transport. However, those having ordinary skill in the art will appreciate that exemplary containers according to embodiments of the application is not limited to such trailers and may encompass, by way of example only and not by way of limitation, transport refrigeration systems for intermodal use, trailers adapted for piggy-back use, railroad cars, and container bodies contemplated for land and sea service.

[00060] Components of the transport refrigeration unit (*e.g.*, motors, fans, sensors), as known to one skilled in the art, can communicate with a controller (*e.g.*, transport refrigeration unit) through wire or wireless communications. For example, wireless communications can include one or more radio transceivers such as one or more of 802.11 radio transceiver, Bluetooth radio transceiver, GSM/GPS radio transceiver or WIMAX (802.16) radio transceiver. Information collected by sensor and components can be used as input parameters for a controller to control various components in transport refrigeration systems. In one embodiment, sensors may monitor additional criteria such as humidity, species concentration or the like in the container.

[00061] Embodiments of systems, apparatus, and/or methods can provide power management system configurations and control for integrating solar power into the electrical system of a transport refrigeration system. Embodiments can ensure real-time allocation of power flow into the refrigeration system, both as a function of load or demand, and/or solar energy availability. In one embodiment, thin-film solar fabrics removably attached to the surfaces of the container or trailer body to allow removal and re-installation depending on operational needs in the field.

[00062] While the present invention has been described with reference to a number of specific embodiments, it will be understood that the true spirit and scope of the invention should be determined only with respect to claims that can be supported by the present specification. Further, while in numerous cases herein wherein systems and apparatuses and methods are described as having a certain number of elements it will be understood that such systems, apparatuses and methods can be practiced with fewer than the mentioned certain number of elements. Also, while a number of particular embodiments have been set forth, it will be understood that features and aspects that have been described with reference to each particular embodiment can be used with each remaining particularly set forth embodiment. For example, aspects and/or features of embodiments described with respect to FIG. 5 can be combined with aspects or features of embodiments described with respect to FIG. 1 or FIG. 4.

WE CLAIM:

1. A transport refrigeration system, comprising:
 - a compressor;
 - a first electric motor that provides a motive force to the compressor;
 - at least one fan;
 - a second electric fan motor that provides a motive force to the fan;
 - a solar PV electrical power source;
 - an electric energy power source;
 - a engine driven generator electrical power source; and
 - a power management controller coupled to route power selectively and concurrently from two of the electrical power sources to provide electrical power to the first motor and the second motor.
2. The transport refrigeration system of claim 1, wherein the received power is provided responsive to a dynamic load of the transport refrigeration system.
3. The transport refrigeration system of claim 2, wherein the dynamic load comprises a single phase AC load, a three phase AC load or any DC load.
4. The transport refrigeration system of claim 2, where the power management controller comprises:
 - a DC/DC converter connected to the solar PV electrical power source and the electric energy power source;
 - a DC power bus connected between the DC/DC converter and at least one DC fan motor;
 - an AC power bus connected between the engine driven generator electrical power source and the first electric motor.
5. The transport refrigeration system of claim 2, where the power management controller comprises:
 - an AC power bus to connect the engine driven generator electrical power source to the first electric motor and the second electric fan motor;
 - a first control circuit connected to control the generator electrical power source;

a first DC/AC converter connected to the solar PV electrical power source and the AC power bus;

a second control circuit connected to control the solar PV electrical power source;

a second DC/AC converter connected to the energy storage electrical power source and the AC power bus; and

a third control circuit connected to control the energy storage electrical power source.

6. The transport refrigeration system of claim 2, where the power management controller comprises:

an AC power bus to connect the power management controller to the first electric motor and the second electric fan motor;

a first control circuit connected to control start-up and shut-down for an engine connected to provide motive force to the generator electrical power source;

where the power management controller is directly connected to receive electrical energy from the generator electrical power source, the solar PV electrical power source, and the electric energy power source; and

where the power management controller is configured to control peak power monitoring of the solar PV electrical power source.

7. The system of claim 1, including a condenser fan assembly having at least one fan motor and an evaporator fan assembly having at least one fan motor and wherein the power management controller routes electrical power to the condenser fan assembly and the evaporator fan assembly.

8. The transport refrigeration system of claim 1, wherein the power management controller provides peak-power tracking of the solar PV system.

9. The transport refrigeration system of claim 1, wherein the power management controller transitions between the solar PV system, the electric energy power source and the generator to provide temperature control for a container.

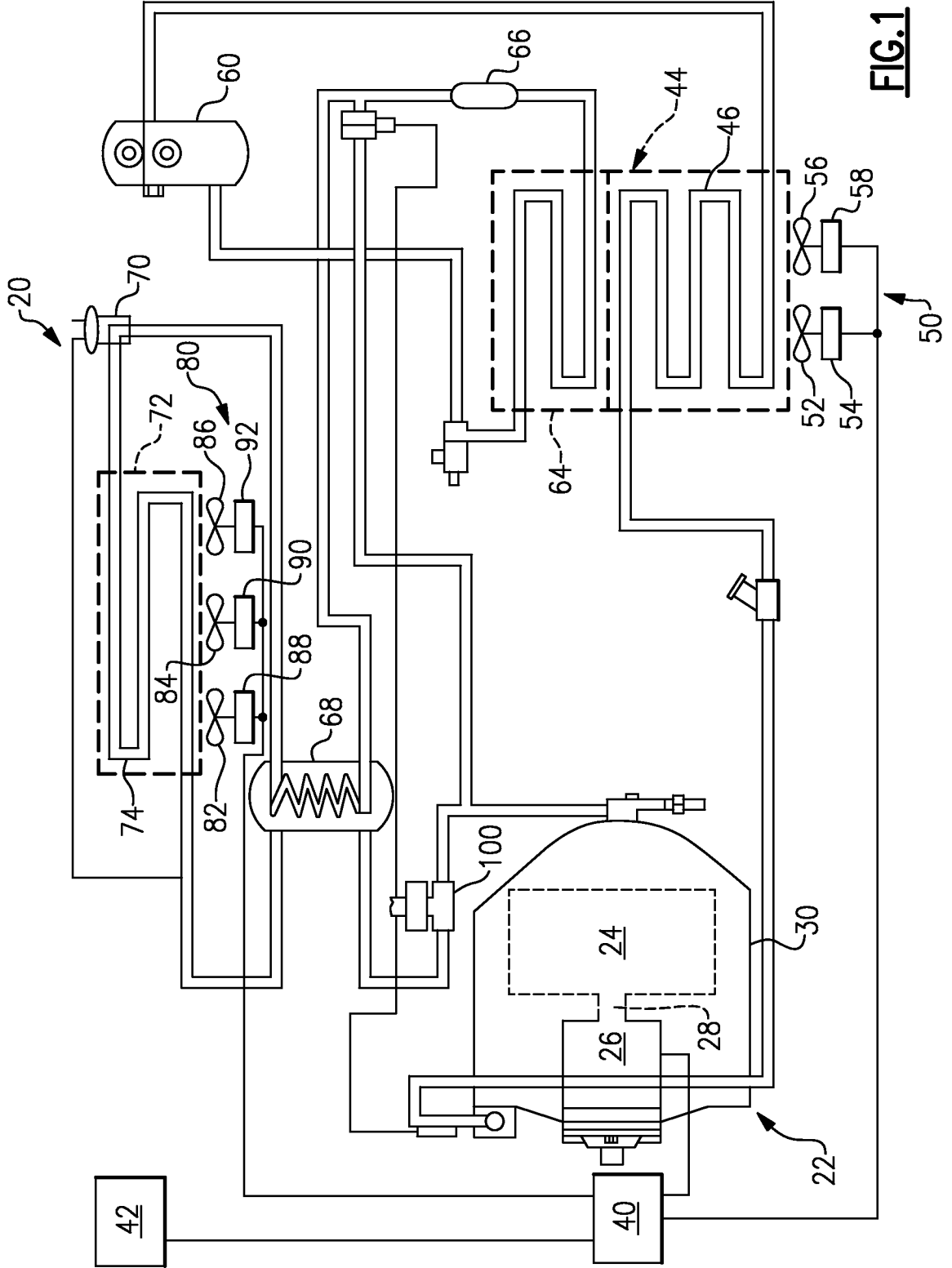

FIG. 1

2/8

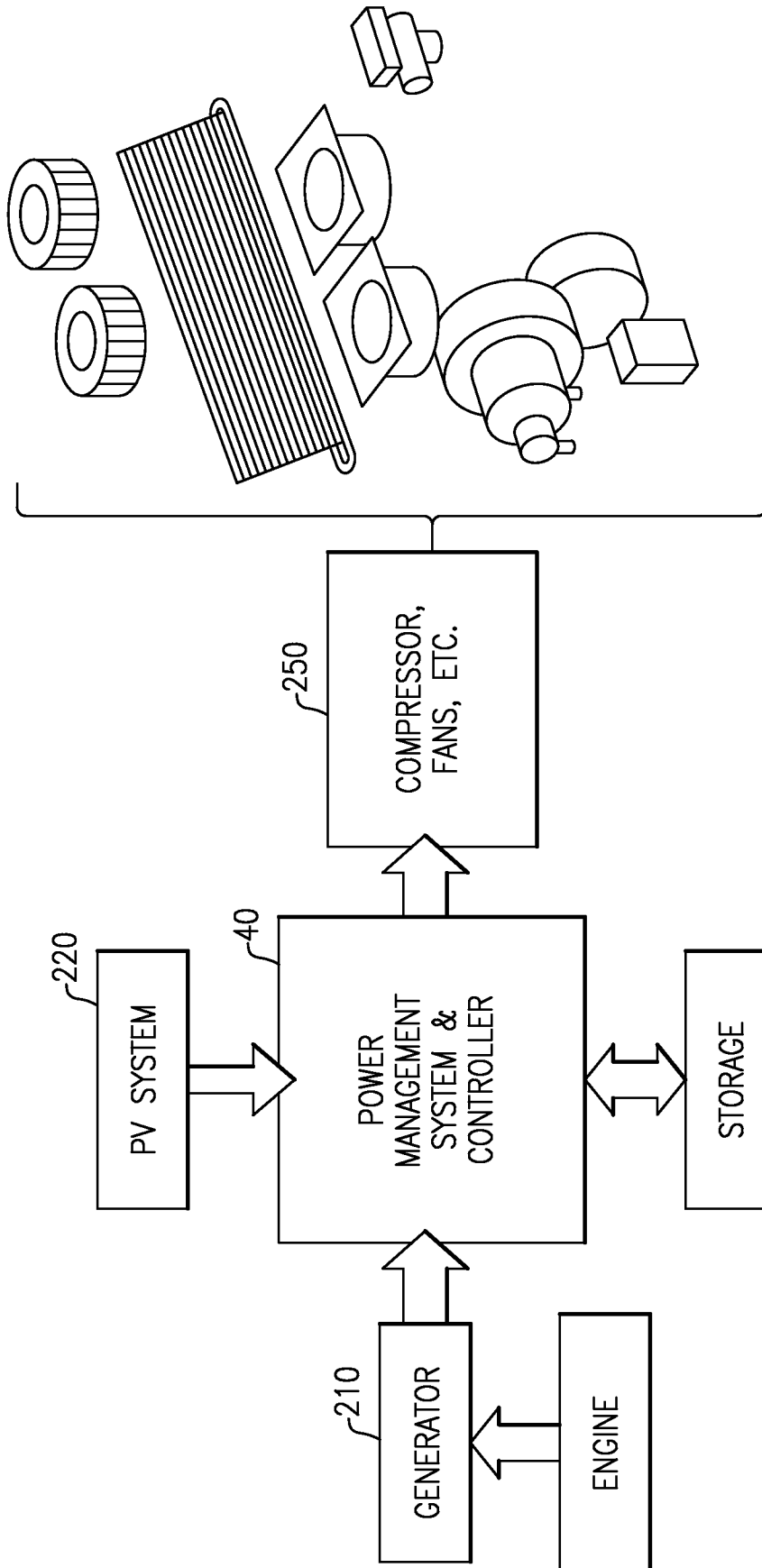

FIG. 2

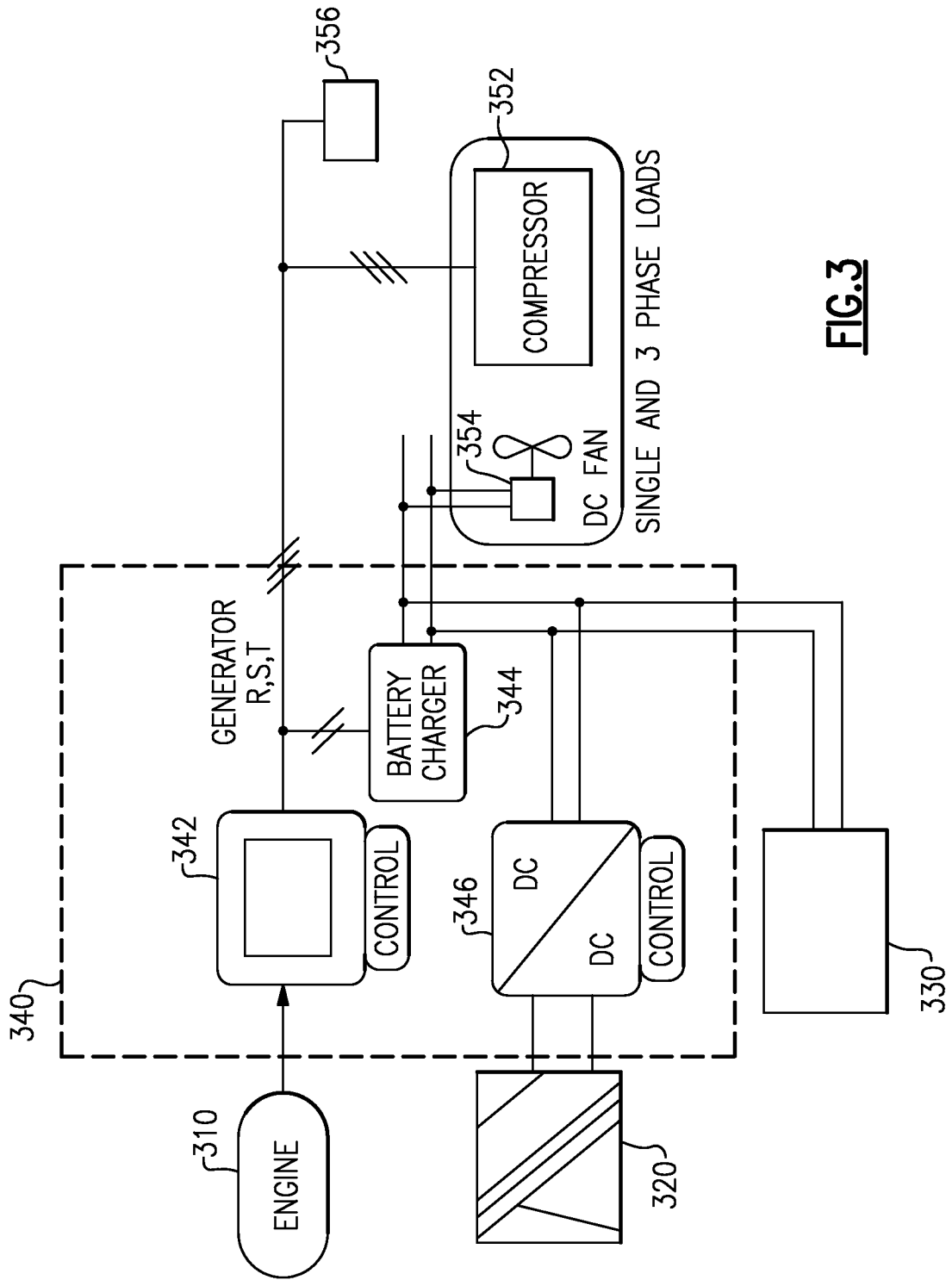

FIG.3

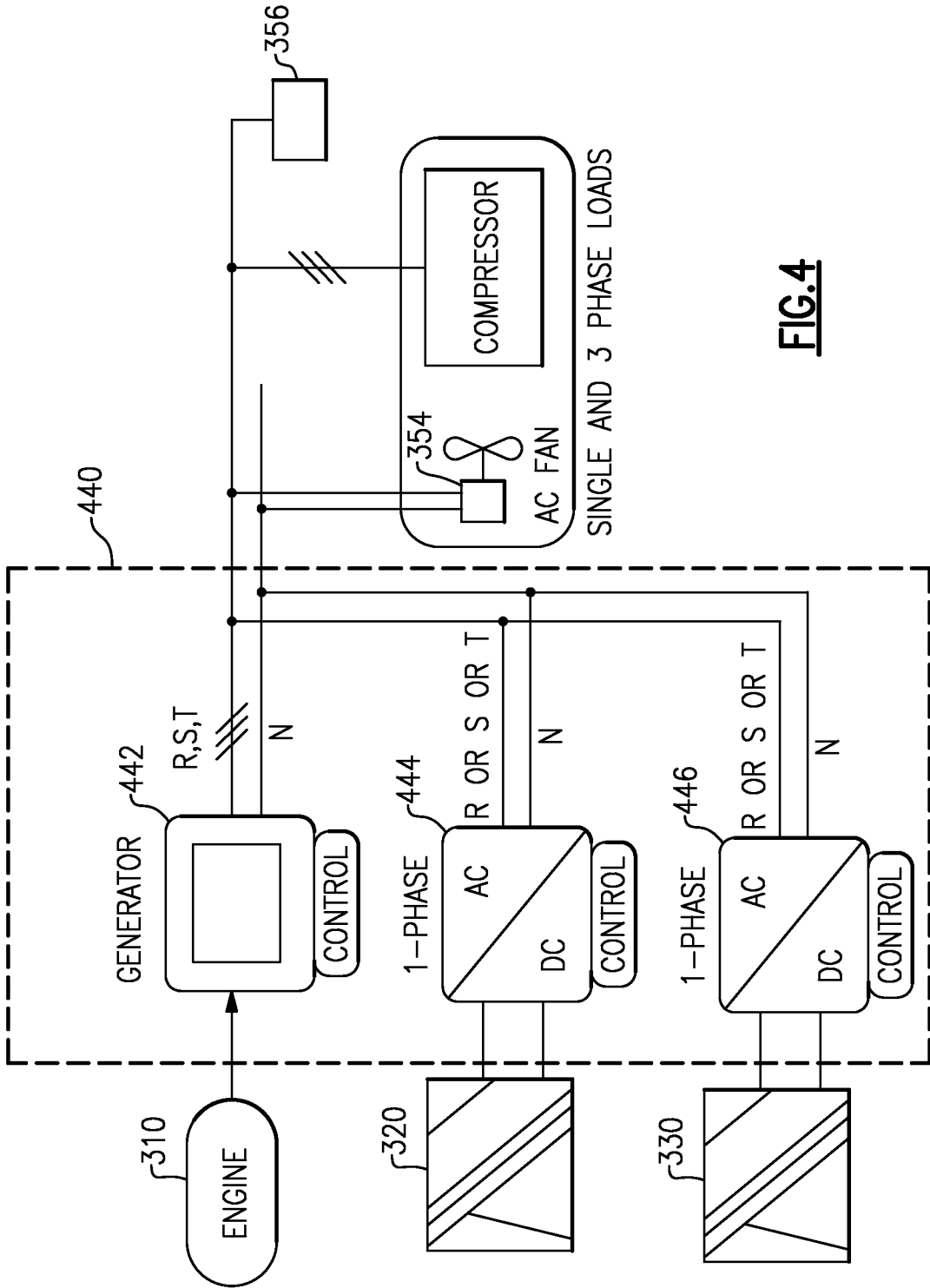

FIG. 4

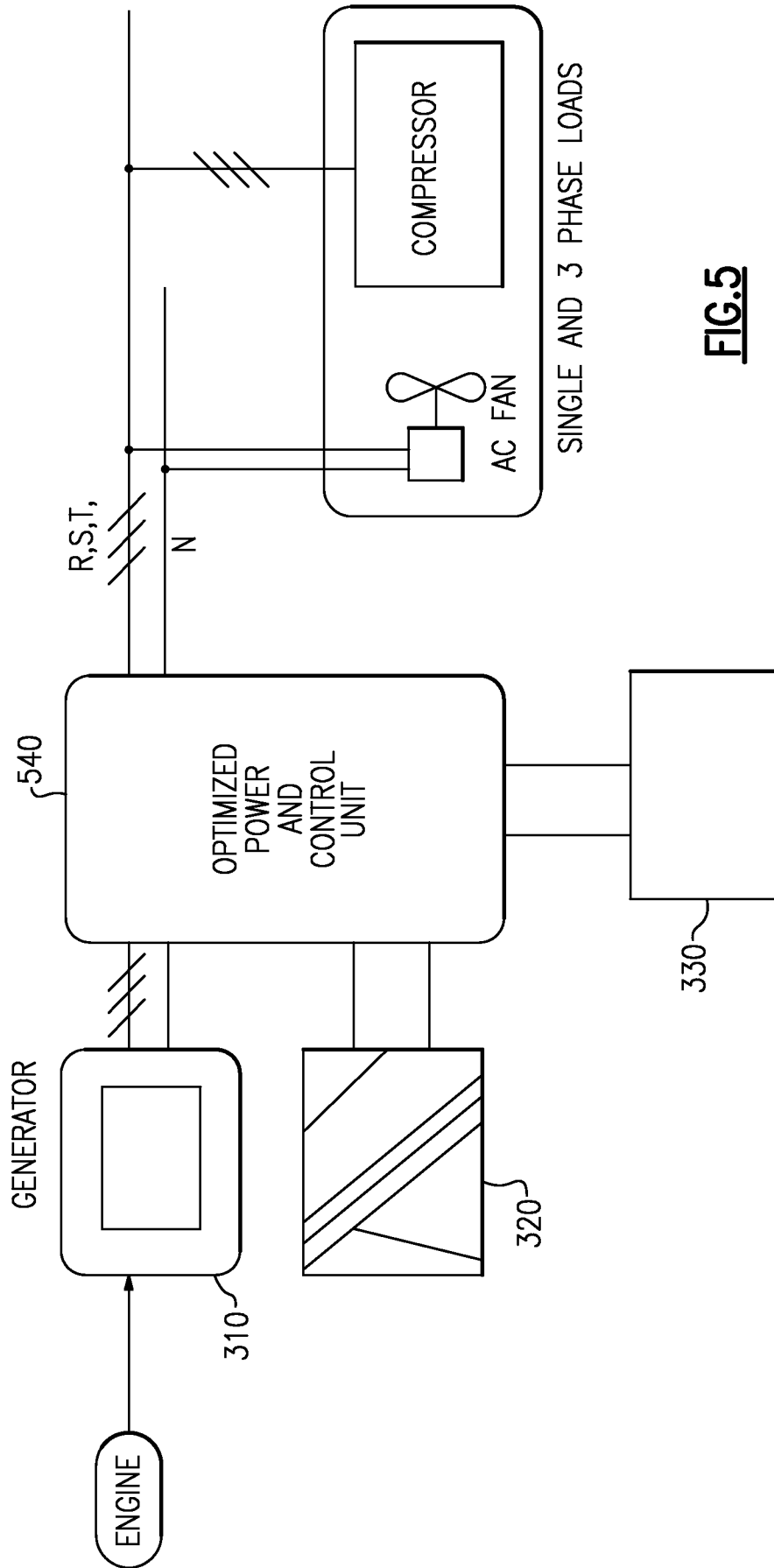

FIG. 5

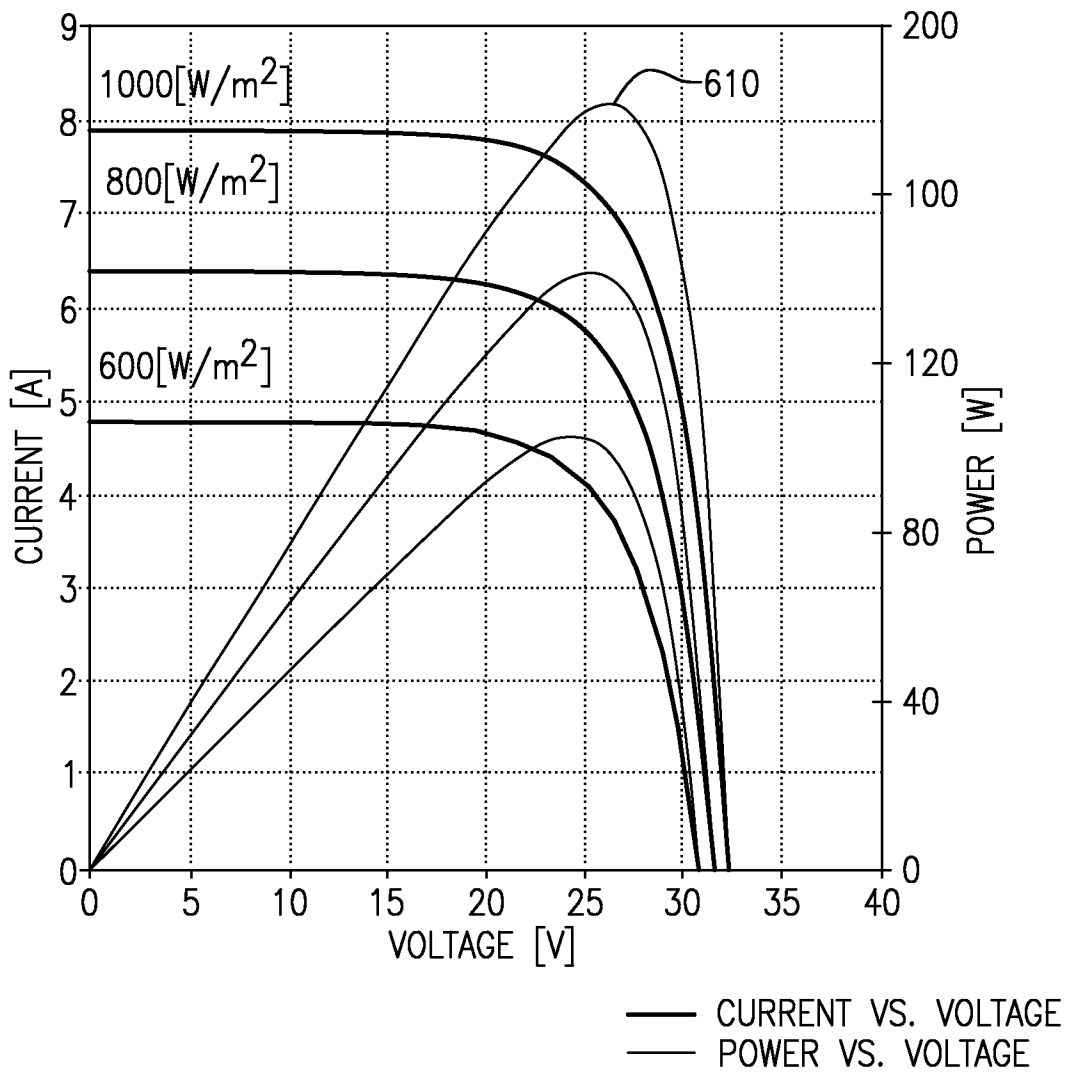

FIG.6

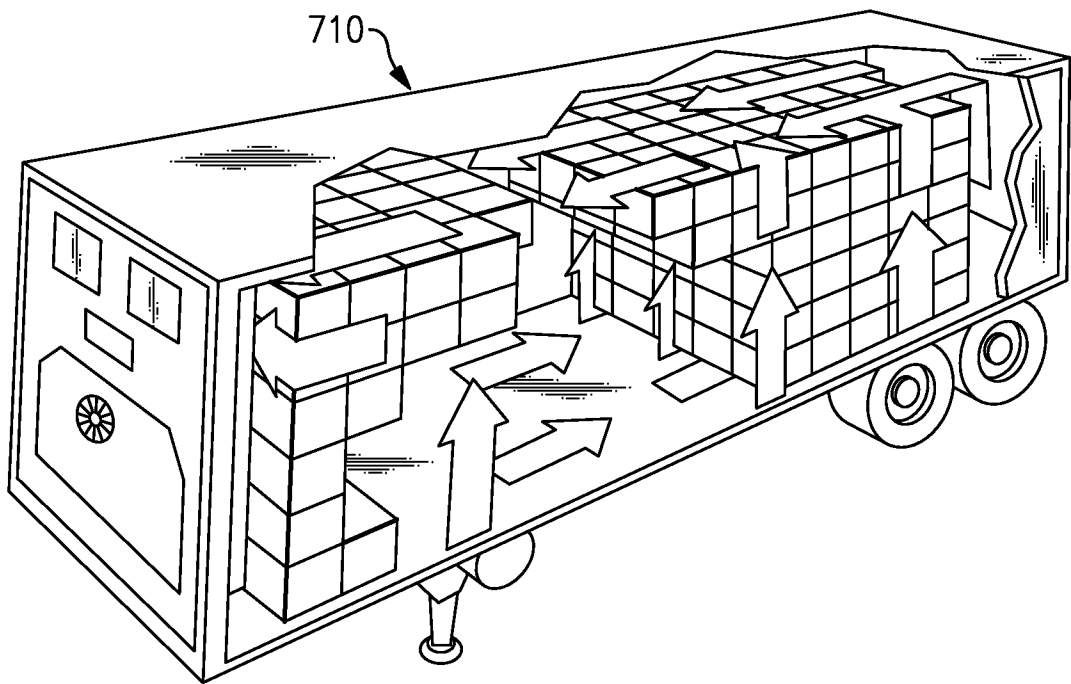

FIG. 7

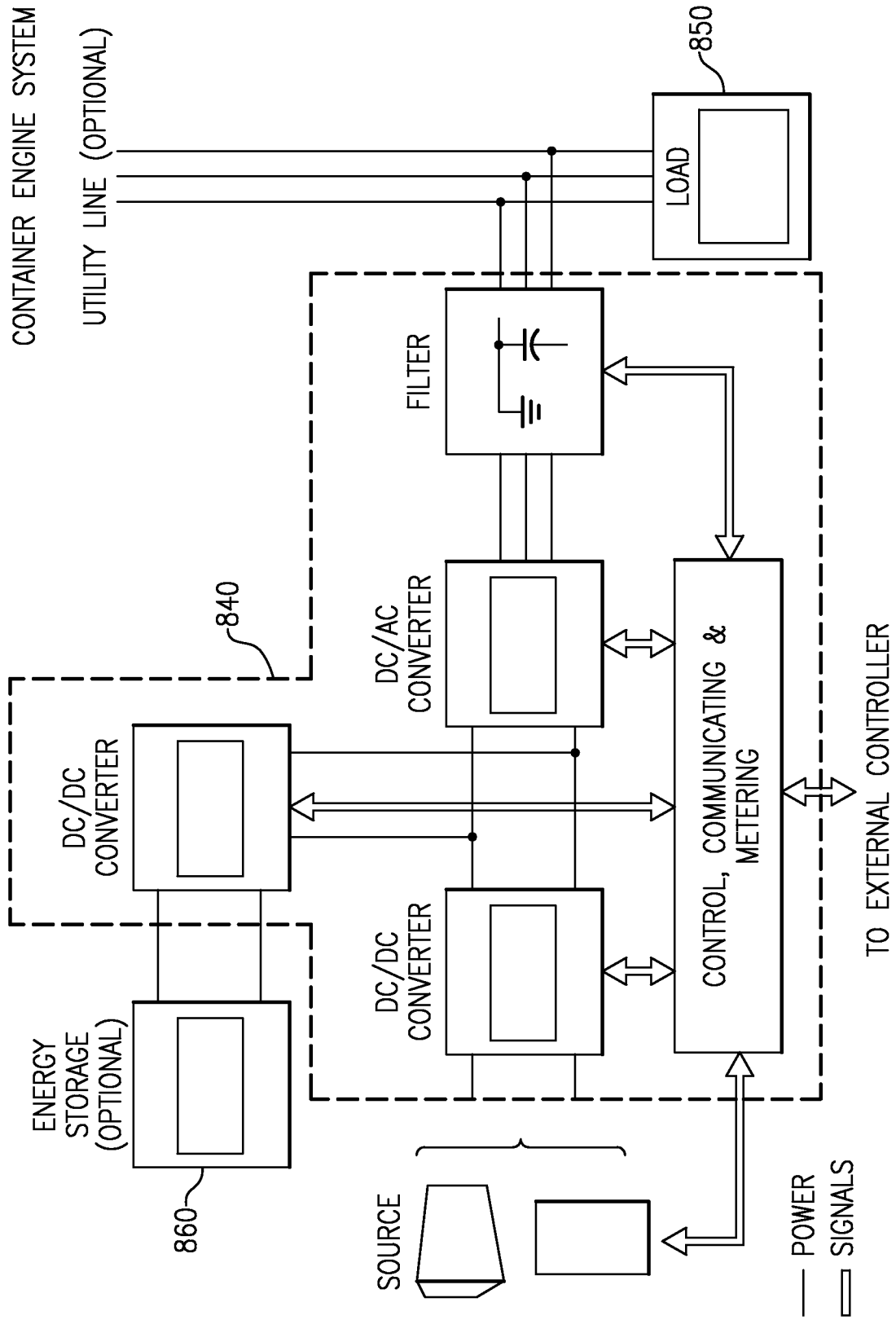

FIG. 8

INTERNATIONAL SEARCH REPORT

International application No
PCT/US2011/021694

A. CLASSIFICATION OF SUBJECT MATTER
 INV. B60H1/00 B60H1/32 F25B27/00
 ADD.
 According to International Patent Classification (IPC) or to both national classification and IPC

B. FIELDS SEARCHED
 Minimum documentation searched (classification system followed by classification symbols)
 B60H F25B

Documentation searched other than minimum documentation to the extent that such documents are included in the fields searched

Electronic data base consulted during the international search (name of data base and, where practical, search terms used)
 EPO-Internal

C. DOCUMENTS CONSIDERED TO BE RELEVANT

Category*	Citation of document, with indication, where appropriate, of the relevant passages	Relevant to claim No.
X	US 2008/257622 A1 (TESCHNER HELMUT [DE] ET AL) 23 October 2008 (2008-10-23)	1-4,7,8
Y	paragraph [0027]; figure 1	9
X	DE 10 2008 009848 A1 (BITZER KUEHLMASCHINENBAU GMBH [DE]) 13 August 2009 (2009-08-13)	1-3,7,8
X	paragraph [0027]; figure 2	
X	US 5 479 557 A (GANZ THOMAS [DE] ET AL) 26 December 1995 (1995-12-26)	1
X	abstract	
X	US 6 253 563 B1 (EWERT MICHAEL K [US] ET AL) 3 July 2001 (2001-07-03)	1
	figure 2	
	----- -/--	

Further documents are listed in the continuation of Box C.

See patent family annex.

* Special categories of cited documents :

<p>"A" document defining the general state of the art which is not considered to be of particular relevance</p> <p>"E" earlier document but published on or after the international filing date</p> <p>"L" document which may throw doubts on priority claim(s) or which is cited to establish the publication date of another citation or other special reason (as specified)</p> <p>"O" document referring to an oral disclosure, use, exhibition or other means</p> <p>"P" document published prior to the international filing date but later than the priority date claimed</p>	<p>"T" later document published after the international filing date or priority date and not in conflict with the application but cited to understand the principle or theory underlying the invention</p> <p>"X" document of particular relevance; the claimed invention cannot be considered novel or cannot be considered to involve an inventive step when the document is taken alone</p> <p>"Y" document of particular relevance; the claimed invention cannot be considered to involve an inventive step when the document is combined with one or more other such documents, such combination being obvious to a person skilled in the art.</p> <p>"&" document member of the same patent family</p>
--	--

Date of the actual completion of the international search 14 April 2011	Date of mailing of the international search report 26/04/2011
--	--

Name and mailing address of the ISA/ European Patent Office, P.B. 5818 Patentlaan 2 NL - 2280 HV Rijswijk Tel. (+31-70) 340-2040, Fax: (+31-70) 340-3016	Authorized officer Marangoni, Giovanni
--	---

INTERNATIONAL SEARCH REPORT

International application No

PCT/US2011/021694

C(Continuation). DOCUMENTS CONSIDERED TO BE RELEVANT

Category*	Citation of document, with indication, where appropriate, of the relevant passages	Relevant to claim No.
Y	WO 2004/065865 A1 (INST LUFT UND KAELTETECHNIK GG [DE]; METALL GMBH K [DE]; RUDISCHER RAI) 5 August 2004 (2004-08-05) paragraph [0004] -----	9

INTERNATIONAL SEARCH REPORT

Information on patent family members

International application No

PCT/US2011/021694

Patent document cited in search report	Publication date	Patent family member(s)	Publication date
US 2008257622	A1	23-10-2008	
		AU 2007209665 A1	02-08-2007
		BR PI0706451 A2	05-04-2011
		CN 101374684 A	25-02-2009
		WO 2007085239 A1	02-08-2007
		DE 102006003424 A1	02-08-2007
		EP 1976718 A1	08-10-2008
		JP 2009523643 T	25-06-2009
		KR 20080081306 A	09-09-2008

DE 102008009848	A1	13-08-2009	NONE

US 5479557	A	26-12-1995	
		DE 4336223 C1	22-09-1994
		EP 0652137 A1	10-05-1995
		JP 7177682 A	14-07-1995

US 6253563	B1	03-07-2001	
		US 2002023450 A1	28-02-2002
		US 2002020181 A1	21-02-2002

WO 2004065865	A1	05-08-2004	
		DE 10301878 A1	05-08-2004
