

No. 633,500.

Patented Sept. 19, 1899.

F. BURGER.  
ADJUSTABLE TIE PLATE.

(Application filed Jan. 9, 1899.)

(No Model.)

2 Sheets—Sheet 1.

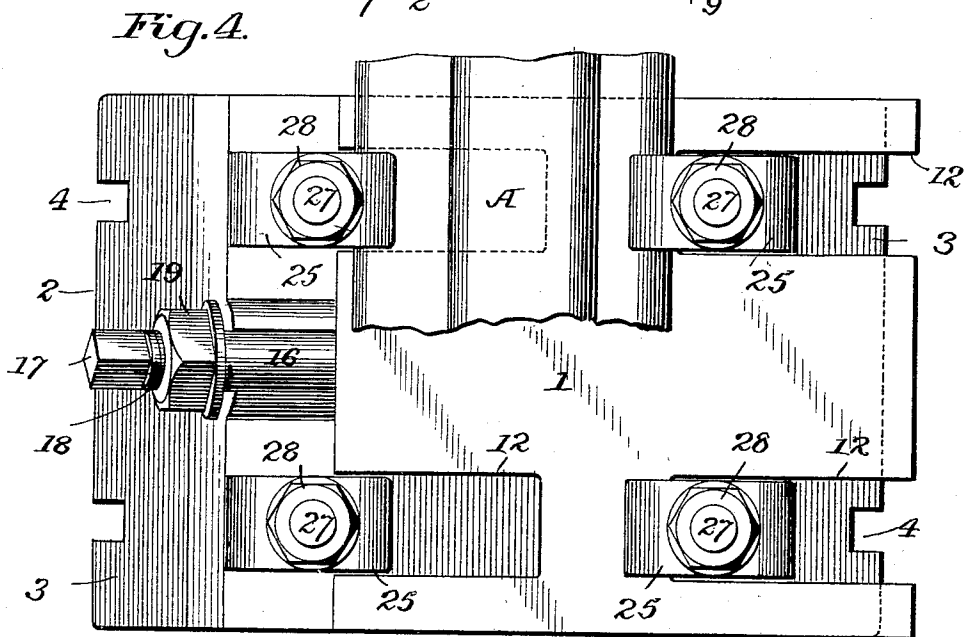
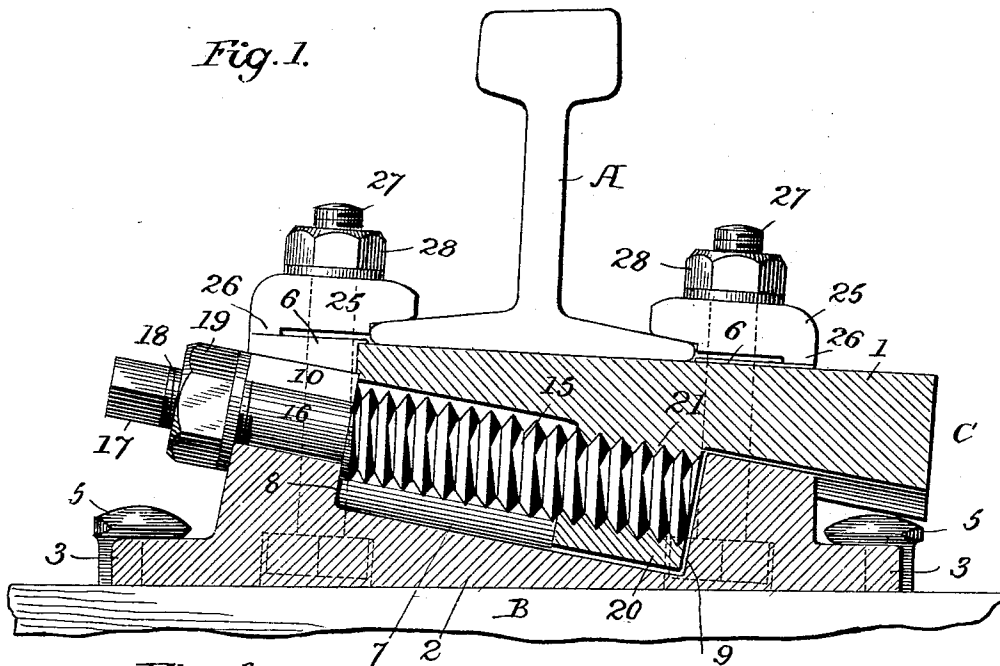

Witnesses  
*H. Hinkel*  
*Harry C. Hay*

Inventor  
*Franz Burger*  
by *John Freeman*  
Attorneys

F. BURGER.  
ADJUSTABLE TIE PLATE.

(Application filed Jan. 9, 1899.)

(No Model.)

2 Sheets—Sheet 2.

Fig. 2.

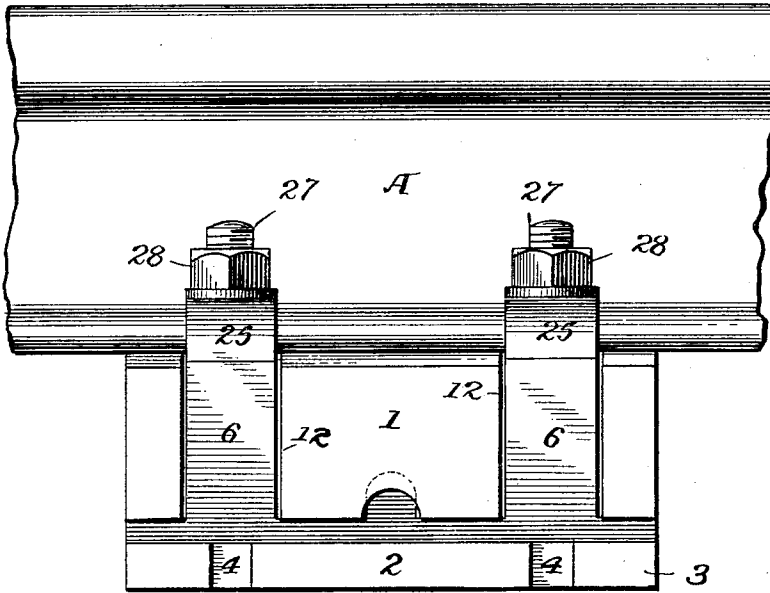
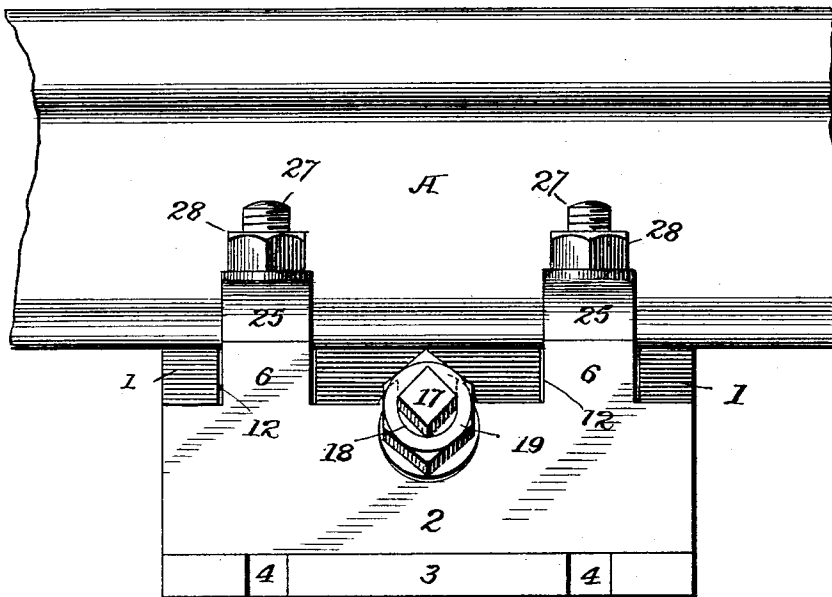

Fig. 3.



Witnesses  
*J. Hinkel*  
*Harry E. Hay*

Inventor  
*Franz Burger*  
 by *Joseph Freeman*  
 Attorneys

# UNITED STATES PATENT OFFICE.

FRANZ BURGER, OF FORT WAYNE, INDIANA, ASSIGNOR OF THREE-FOURTHS  
TO HENRY M. WILLIAMS, OF SAME PLACE.

## ADJUSTABLE TIE-PLATE.

SPECIFICATION forming part of Letters Patent No. 633,500, dated September 19, 1899.

Application filed January 9, 1899. Serial No. 701,657. (No model.)

*To all whom it may concern:*

Be it known that I, FRANZ BURGER, a citizen of the United States, residing at Fort Wayne, in the county of Allen and State of Indiana, have invented certain new and useful Improvements in Adjustable Tie-Plates, of which the following is a specification.

This invention relates to certain new and useful improvements in adjustable tie-plates more especially adapted for use at the curves in railway-tracks, but equally applicable for use upon the straight sections thereof, the invention having for its object to provide a simple and effective tie-plate which in use will prevent spreading of the rails of a track and by means of which the rails may be raised or lowered relative to a cross-tie or in relation to each other.

With this object in view the invention consists in the novel construction, combination, and arrangement of the parts hereinafter pointed out with greater particularity.

In the accompanying drawings, forming a part of this specification, and in which like letters and figures of reference indicate corresponding parts, Figure 1 is a sectional view of a tie-plate embodying the invention, a rail being shown secured thereto. Fig. 2 is an end view of one end of the tie-plate. Fig. 3 is a similar view of the opposite end thereof; and Fig. 4 is a plan view of the tie-plate, the rail being indicated in dotted lines.

Referring more particularly to the drawings, A designates a rail of a railway-track, B a cross-tie, and C one of the tie-plates upon which the rails are supported. As shown, the tie-plate is formed of an upper and a lower or base section 1 2, respectively, and each of these sections is wedge-shaped in longitudinal cross-section, and they are adapted to be adjusted one upon the other—that is to say, each of the sections is formed with upper and lower faces one of which is inclined with respect to the other, and normally the thickest portion of one of the sections rests upon the thinnest portion of the opposing section in order that a rail resting upon the upper section will be raised or lowered accordingly as said section is moved upwardly or down-

wardly upon the inclined surface of the lower section.

Different means may be employed for adjusting the tie-plate sections relative to each other, but that shown is preferred on account of its simplicity, inexpensiveness, and effectiveness. Thus the lower tie-plate section 2 is formed with transverse flanges 3, in the edges of which are formed openings or recesses 4 for reception of spikes 5, by means of which the said section is secured to the cross-tie.

Near each transverse edge the lower section 2 is formed with one or more vertically-extending projections 6, which serve the combined purpose of bearings and guides in the manner hereinafter more fully described. As shown, there are two of these guiding-bearings 6 near each edge of the section 2, and such projections are arranged at separated points.

In the transverse center of the lower tie-plate section is formed a longitudinally-extending recess 7, the end walls of which constitute bearings 8 9, and the bearing 8 is formed with a vertical slot or recess 10, which extends from the upper face of the tie-plate section, as does also the recess 7.

Upon the upper inclined face of the lower tie-plate section 2 rests the upper section 1, with its inclined face engaging that of the lower section. The said upper section is provided with elongated slots 12, which, as shown, extend inwardly from the transverse edges of the section 1 and are adapted to receive the bearings 6 and conform closely to the side edges thereof to prevent lateral shifting of the tie-plate sections relative to each other. The slots 12 being elongated, the upper tie-plate section may be moved longitudinally up or down the inclined surface of the lower section by any suitable adjusting means. A simple construction for effecting this adjustment consists of an adjusting bolt or screw having an inner threaded portion 15, a smooth portion 16 contiguous thereto, but of less diameter, a many-sided outer end 17 for reception of a wrench, and a second threaded portion 18 for receiving a securing-nut 19.

The smooth portion 16 of the bolt is adapted to be received in the slot 10, and the threaded portion 15 extends longitudinally and centrally through the recess 7 and bears at its extreme end upon the bearing 9, the shoulder intermediate the smooth and threaded portions 15 16 engaging the inner surface of the bearing 8 upon opposite sides of the slot thereof. The threaded portion 18 of the bolt projects beyond the bearing and receives the lock or securing nut 19, which when tightened against the outer face of the bearing holds the bolt against rotation.

Extending from the lower face of the upper tie-plate section into the recess 7 is a projection 20, having a threaded opening 21, through which the threaded portion 15 of the bolt extends.

From the above it will be apparent that by loosening the securing-nut 19 and turning the adjusting-bolt the upper tie-plate section may be readily moved in either direction upon the lower section and a rail resting thereon may be raised or lowered.

As is well known, cross-ties often settle under the weight of trains passing over the rails of a track, and thereby more firmly embed themselves in the track-bed and secure a better foundation, and it has been customary heretofore to raise the cross-ties to their proper level by tamping earth beneath them, thus destroying the foundation which they have made for themselves. This is very undesirable and is overcome by the employment of the adjustable tie-plate above described, since it will be apparent that the rails of a track may be raised or lowered, as desired, without the necessity of changing the position of the cross-ties beneath the same.

Various devices may be employed for securing rails to the upper tie-plate sections; but it is preferred to effect this by means of clamping-plates 25, which engage and conform to the edges of the rail-bases at their rear edges. The clamping-plates are formed with toes 26, which bear upon the upper faces of the projections 6. As a convenient means of holding the plates 25 into firm contact with the rails and projections 6 bolts 27 are employed, which have their heads countersunk in recesses in the lower faces of the lower tie-plate section 2, and said bolts extend vertically through the said lower section and through the slots 12 of the upper section and

passing through the clamping-plates receive nuts 28 at their upper ends, which nuts serve to hold the plates in place.

Without limiting myself to the precise construction and operation of the parts shown and described, since it will be obvious that various changes in such construction and arrangement may be made without departing from the spirit or scope of the invention and some of the features of the invention used without others,

What I claim is—

1. A tie-plate comprising two superposed sections wedge-shaped in cross-section and an adjusting-screw engaging both of the sections for moving them, one in relation to the other, substantially as described.

2. A tie-plate comprising two superposed sections, each wedge-shaped in cross-section, one of said sections being formed with slots and the other with guiding projections adapted to engage the same, and means for adjusting the sections one in relation to the other, substantially as described.

3. A tie-plate comprising a lower section formed with recessed flanges at its transverse edges, an upper section superposed upon the first, each of said sections being wedge-shaped in cross-section, and means for adjusting the upper section upon the lower section, substantially as described.

4. A tie-plate comprising two superposed sections, each being wedge-shaped in cross-section, one of said sections being formed with a bearing and with a recess and the other with a projection extending into the recess of the opposing section and having a threaded opening and an adjusting-screw extending through the recess and engaging the bearing and the threaded opening of the two sections, respectively, substantially as set forth.

5. A tie-plate comprising two superposed sections wedge-shaped in cross-section and mechanical means for moving one of said sections in relation to the other, substantially as described.

In testimony whereof I have signed my name to this specification in the presence of two subscribing witnesses.

FRANZ BURGER.

Witnesses:

GEO. K. TORRENCE,  
J. V. LOCHINE.