



- (51) International Patent Classification:  
A61L 2/16 (2006.01)
- (21) International Application Number:  
PCT/US2015/029019
- (22) International Filing Date:  
4 May 2015 (04.05.2015)
- (25) Filing Language: English
- (26) Publication Language: English
- (30) Priority Data:  
61/987,981 2 May 2014 (02.05.2014) US
- (71) Applicant: EXCELSIOR MEDICAL CORPORATION  
[US/US]; 1933 Heck Avenue, Neptune, NJ 07753 (US).
- (72) Inventor: GARDNER, Christopher, E.; 5 Ogden Lane,  
Manalapan, NJ 07726 (US).
- (74) Agent: FRISCIA, Michael, R.; McCarter & English, LLP,  
Four Gateway Center, 100 Mulberry Street, Newark, NJ  
07102 (US).
- (81) Designated States (unless otherwise indicated, for every  
kind of national protection available): AE, AG, AL, AM,

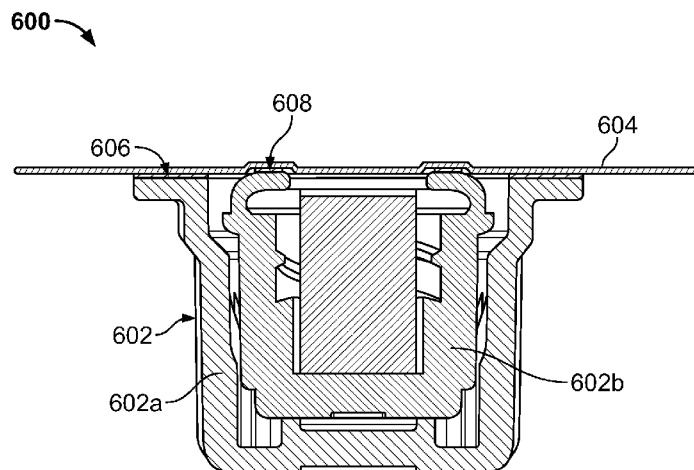
AO, AT, AU, AZ, BA, BB, BG, BH, BN, BR, BW, BY,  
BZ, CA, CH, CL, CN, CO, CR, CU, CZ, DE, DK, DM,  
DO, DZ, EC, EE, EG, ES, FI, GB, GD, GE, GH, GM, GT,  
HN, HR, HU, ID, IL, IN, IR, IS, JP, KE, KG, KN, KP, KR,  
KZ, LA, LC, LK, LR, LS, LU, LY, MA, MD, ME, MG,  
MK, MN, MW, MX, MY, MZ, NA, NG, NI, NO, NZ, OM,  
PA, PE, PG, PH, PL, PT, QA, RO, RS, RU, RW, SA, SC,  
SD, SE, SG, SK, SL, SM, ST, SV, SY, TH, TJ, TM, TN,  
TR, TT, TZ, UA, UG, US, UZ, VC, VN, ZA, ZM, ZW.

- (84) Designated States (unless otherwise indicated, for every  
kind of regional protection available): ARIPO (BW, GH,  
GM, KE, LR, LS, MW, MZ, NA, RW, SD, SL, ST, SZ,  
TZ, UG, ZM, ZW), Eurasian (AM, AZ, BY, KG, KZ, RU,  
TJ, TM), European (AL, AT, BE, BG, CH, CY, CZ, DE,  
DK, EE, ES, FI, FR, GB, GR, HR, HU, IE, IS, IT, LT, LU,  
LV, MC, MK, MT, NL, NO, PL, PT, RO, RS, SE, SI, SK,  
SM, TR), OAPI (BF, BJ, CF, CG, CI, CM, GA, GN, GQ,  
GW, KM, ML, MR, NE, SN, TD, TG).

**Published:**

— with international search report (Art. 21(3))

(54) Title: STRIP PACKAGE FOR ANTISEPTIC CAP



DETAIL B  
SCALE 2:1

FIG. 65

(57) Abstract: A syringe assembly includes (1) a syringe barrel defining a chamber; (2) a plunger mounted in the chamber and moveable with respect to the barrel; and (3) a cap assembly containing a cap and an absorbent material is removably attached to the plunger. A strip package includes at least two cap assemblies. Each of the cap assemblies includes a cap holder and an antiseptic cap positioned in the cap holder. The antiseptic cap includes a sidewall defining a chamber and an antiseptic substance within the chamber. A strip extends over at least two cap assemblies. The strip includes a first seal engaged to the cap holder and a second seal engaged to the antiseptic cap.

WO 2015/168677 A1

## STRIP PACKAGE FOR ANTISEPTIC CAP

### CROSS-REFERENCE TO RELATED APPLICATIONS

The present application claims the priority of U.S. Provisional Application Serial No. 61/987,981 filed May 2, 2014, the disclosure of which is expressly incorporated herein by reference in its entirety.

### BACKGROUND OF THE INVENTION

#### Technical Field

The present invention relates to an antiseptic cap having a thread cover to enhance a seal between the cap and an access site to a body of a mammal. More particularly the invention relates to an antiseptic cap for attaching to an access site of an indwelling, central venous catheter and having a thread cover to enhance a seal between the cap and the access site.

#### Background Art

Catheters are widely used to treat patients requiring a variety of medical procedures. Catheters can either be acute, or temporary, for short-term use or chronic for long-term treatment. Catheters are commonly inserted into central veins (such as the vena cava) from peripheral vein sites to provide access to a patient's vascular system. Catheters offer many advantages for patients; for example, chronic catheters provide ready access without repeated punctures or repeated vessel cannulation for administration of large volumes of fluids, nutrients and medications and for withdrawal of blood on an intermittent basis. With respect to the use of catheters for infusion of fluids, examples include the infusion of drugs, electrolytes or fluids used in chemotherapy. In chemotherapy, catheters are used for infusion of drugs on an intermittent basis, ranging from daily to weekly. Another example includes the use of catheters in hyperalimentation treatment, wherein the catheters are usually used for infusion of large volumes of fluids.

For hemodialysis, catheters are commonly used--usually three times per week--for aspiration of blood for dialysis treatment and rapid return of the blood to circulation after treatment. Although a preferred mode of vascular access for a hemodialysis patient involves using an arteriovenous (AV) fistula of either the upper or lower extremities or an arteriovenous "bridge" graft (typically utilizing PTFE), use of these access devices is not

always possible or desirable. When either of these modes of vascular access is not available, for example, due to a paucity of adequate blood vessels for creation of AV “shunts” or due to nonoptimally functioning established AV shunts, a large bore venous line catheter is typically required for hemodialysis. Catheters used for hemodialysis usually include two relatively large diameter lumens (usually molded as one catheter) for aspiration and rapid return of blood required during the hemodialysis procedure. One lumen of such a catheter is used for aspiration, or removal, of blood, while the other lumen is used for returning the blood to the patient's bloodstream.

Catheter connections, such as, for example, connections of catheters to dialysis machine tubing, to IV line tubing, to infusion ports and to catheter caps, which are used to seal the end of a catheter to protect the sterility of the catheter and prevent fluid loss and/or particle contamination, are most often made utilizing the medical industry's standardized Luer taper fittings. These fittings, which may either be male couplings or female couplings, include a tapered end of standardized dimensions. Coupling is made by the press-fit of mating parts. A threaded lock-fit or other type of securing mechanism is commonly utilized to ensure the integrity of the pressure fit of the Luer fittings.

Catheters, especially chronic venous catheters, provide challenges in their use. One such challenge is that such catheters can become occluded by a thrombus. In order to prevent clotting of catheters in blood vessels between uses, such as, for example, between dialysis treatments when the catheter is essentially nonfunctioning and dwells inside a “central” vein (i.e. superior vena cava, inferior vena cava, iliac, etc), the lumens of the catheter are often filled with a lock solution of a concentrated solution of the commonly used anticoagulant, heparin (up to 10,000 units of heparin per catheter lumen).

As used herein, the terms “lock solution” or “locking solution” refer to a solution that is injected or otherwise infused into a lumen of a catheter with the intention of allowing a substantial portion of the lock solution to remain in the lumen and not in the systemic blood circulation until it is desired or required to access that particular lumen again, typically for additional treatment, i.e., infusion or withdrawal of fluid. In addition, attention has been given to the development of alternative lock solutions with the goal of improving the patency rates of vascular catheters. For example, lower-alcohol containing locking solutions are under development wherein the lower alcohols include ethanol, propanol and butanol. Anti-microbial and or anticoagulant additives can optionally be added to the lower-alcohol containing locking solution. Preferably the lock solution can

remain in the lumen for a desired amount of time lasting from about 1 hour to 3 or 4 days or longer.

For the reasons set forth above, significant care must be taken when infusing medications, nutrients and the like into a catheter, and when “locking” a catheter between uses, to minimize the risks associated with an indwelling catheter, including the risk of thrombosis or clotting, the risk of excessive anticoagulating and the risk of infection. Syringes are typically used to administer the required amount of catheter lock solution (determined by the catheter manufacturer) into an indwelling catheter after a given use. Flush procedures also require that care be taken to prevent blood reflux into the catheter. Reflux in IV therapy is the term commonly used to describe the fluid that is drawn back into the catheter after a flush procedure. The concern is that the reflux fluid contains blood or solution that could cause the catheter to occlude. To ensure that reflux does not occur, flush procedures suggest two techniques: 1) at the end of the flush solution delivery, the user maintains pressure on the syringe plunger while clamping the IV line; or 2) while delivering the last 0.5 ml of flush solution disconnect the syringe from the IV port or clamp the IV line. Either technique maintains positive pressure on the fluid in the catheter to prevent reflux of fluid and blood.

In light of the above-described problems, there is a continuing need for advancements in catheter lock techniques, devices and procedures to improve the safety and efficacy of catheter locking procedures and of overall patient care.

SUMMARY

In accordance with the present disclosure, a package for a cap assembly is provided. The package includes an outer seal engaged to a cap holder, and an inner seal arranged substantially concentric with respect to the outer seal. The inner seal engaged to an antiseptic cap positioned in the cap holder.

In accordance with an embodiment, a strip package includes at least two cap assemblies. Each of the cap assemblies includes a cap holder and an antiseptic cap positioned in the cap holder. The antiseptic cap includes a sidewall defining a chamber and an antiseptic substance within the chamber. A strip extends over at least two cap assemblies. The strip has a sterile cover. The strip includes a first seal engaged to the cap holder and a second seal engaged to the antiseptic cap. In another embodiment, the strip includes a single seal engaged to the cap holder.

BRIEF DESCRIPTION OF THE DRAWINGS

**FIG. 1** is a perspective view of an antiseptic cap equipped plunger and syringe barrel assembly prior to connection of a syringe tip to an access point to a central venous catheter;

**FIG. 2** is a perspective view of an antiseptic cap equipped plunger and syringe barrel assembly with the syringe tip connected to an access point to a central venous catheter;

**FIG. 3** is a perspective view of an antiseptic cap equipped plunger and syringe barrel assembly prior to connection of the antiseptic cap to an access point to a central venous catheter;

**FIG. 4** is a perspective view of an antiseptic cap equipped plunger and syringe barrel assembly after connection of the antiseptic cap to an access point to a central venous catheter;

**FIG. 5** is a perspective view assembly drawing of an antiseptic cap equipped plunger;

**FIG. 6** is a perspective view of an antiseptic cap equipped plunger in a partially assembled state;

**FIG. 7** is a perspective view of the antiseptic cap equipped plunger of **FIG. 6** with a top seal;

**FIG. 8** is a perspective view of an antiseptic cap equipped plunger of **FIG. 7** mounted in a lumen of a syringe barrel;

**FIG. 9** is a side view in cutaway of an antiseptic cap equipped plunger and syringe barrel assembly;

**FIG. 10** shows an exploded view of a detail of **FIG. 9** of one embodiment of the antiseptic cap equipped plunger and syringe barrel assembly;

**FIG. 11** shows an exploded view of a detail of **FIG. 9** of another embodiment of the antiseptic cap equipped plunger and syringe barrel assembly;

**FIGS. 12-14** show various embodiments of grips of the antiseptic cap equipped plunger assembly;

**FIGS. 15-17** show various views of one embodiment antiseptic cap equipped plunger and syringe barrel assembly with a barrel lock to resist rotation of the plunger assembly with respect to the syringe barrel;

**FIG. 18** shows another embodiment of a barrel lock to resist rotation of the plunger assembly with respect to the syringe barrel;

**FIGS. 19-20** show various views of another embodiment antiseptic cap equipped plunger and anti-reflux syringe barrel assembly with a barrel lock to resist rotation of the plunger assembly with respect to the syringe barrel;

**FIG. 21** shows a perspective view of another embodiment antiseptic cap equipped plunger and syringe barrel assembly with a barrel lock to resist rotation of the plunger assembly with respect to the syringe barrel;

**FIGS. 22 a,b** are respectively a perspective view of an antiseptic cap without a sponge and with a sponge;

**FIGS. 23** and **24** are different embodiments of the antiseptic cap with varying gripping features;

**FIG. 25** is a perspective view of the antiseptic cap of **FIG. 22b** prior to docking with a valve;

**FIG. 26** is a perspective view of the antiseptic cap of **FIG. 22b** docked with a valve;

**FIG. 27** is a side view in cutaway of the antiseptic cap and valve assembly shown in **FIG. 26**;

**FIGS. 28-30** are side views in cutaway of two different embodiments of the antiseptic cap;

**FIGS. 31 a,b** are, respectively, side views in cutaway showing an antiseptic cap with a centrally disposed actuation post mounted on a valve with the valve in the unactivated and activated positions;

**FIGS. 32** and **33** are side views in cutaway showing two different embodiments of an antiseptic cap having a molded sponge;

**FIG. 34** is a side view in cutaway showing another embodiment of an antiseptic cap having a molded sponge docked to a valve;

**FIG. 35** is a side view in cutaway showing a step of attaching a molded sponge to an antiseptic cap;

**FIG. 36** is a side view in cutaway showing a step of delivering an antiseptic compound to a molded sponge positioned within a cap;

**FIG. 37** shows a side view in cutaway of an antiseptic cap docking to a valve with the antiseptic cap having an antiseptic coating;

**FIG. 38** shows a perspective view of an antiseptic cap in a blister package;

**FIG. 39** is a side cross-sectional view of an antiseptic cap with a thread cover;

**FIG. 40** is a side cross-sectional view of an antiseptic cap with a thread cover;

**FIG. 41** is a side cross-sectional view of an antiseptic cap with a thread cover;

**FIGS. 42a,b** are perspective front and back views of an antiseptic cap with a thread cover connected to a Cardinal SMART SITE access site;

**FIGS. 43 a,b** are perspective front and back views of an antiseptic cap without a thread cover connected to a Cardinal SMART SITE access site;

**FIGS. 44 a,b** are perspective front and back views of an antiseptic cap with a thread cover connected to a Hospira (ICU) C1000 Clave access device;

**FIGS. 45 a,b** are perspective front and back views of an antiseptic cap without a thread cover connected to a Hospira (ICU) C1000 Clave access device;

**FIGS. 46 a,b** are perspective front and back views of an antiseptic cap with a thread cover connected to a B. Braun ULTRASITE access device;

**FIGS. 47 a,b** are perspective front and back views of an antiseptic cap without a thread cover connected to a B. Braun ULTRASITE access device;

**FIGS. 48 a,b** are perspective front and back views of an antiseptic cap with a thread cover connected to a Rymed INVISION PLUS access device;

**FIGS. 49 a,b** are perspective front and back views of an antiseptic cap without a thread cover connected to a Rymed INVISION PLUS access device;

**FIG. 50** is a side cross-sectional view of an antiseptic cap with a thread cover connected to a Cardinal SMARTSITE PLUS access device;

**FIG. 51** is a side cross-sectional view of an antiseptic cap with a thread cover connected to a Cardinal SMARTSITE PLUS access device and the thread cover having a reduced diameter when compared to the thread cover shown in **FIG. 50**;

**FIG. 52** is a side cross-sectional view of an antiseptic cap with a thread cover connected to a Hospira (ICU) C1000 Clave access device having a thread cover with an alternative profile;

**FIG. 53** is an assembly view of an antiseptic cap and cup holder equipped plunger and syringe barrel system;

**FIG. 54** is an assembly view of a cup-holder-antiseptic cap assembly adjacent a plunger and syringe barrel system;



**FIG. 55** is a side view in cross-section of an antiseptic cap and cup holder equipped plunger and syringe barrel assembly;

**FIG. 56a** is a perspective view of a medical access device adjacent an antiseptic cap equipped plunger and syringe barrel assembly with a lid stock peeled back in preparation for docking;

**FIG. 56b** is a perspective view of a medical access device docked to an antiseptic cap equipped plunger and syringe barrel assembly;

**FIG. 56c** is a perspective view of a medical access device docked to an antiseptic cap adjacent a plunger and syringe barrel assembly;

**FIG. 57** is an enlarged view of a cup holder and antiseptic cap assembly adjacent an open and empty chamber of a syringe plunger;

**FIG. 58** is an enlarged view of a cup holder and antiseptic cap assembly positioned within a chamber of a syringe plunger;

**FIG. 59** is a perspective view of an alternative embodiment of an antiseptic cap assembly adjacent a syringe plunger and barrel assembly;

**FIG. 60** is a perspective view of an alternative embodiment of an antiseptic cap assembly docked to a syringe plunger and barrel assembly;

**FIG. 61** is a perspective view of an alternative embodiment of an antiseptic cap assembly docked to a syringe plunger and barrel assembly with an outer wall being transparent to reveal interior portions of the assembly;

**FIG. 62** is a top view of a strip package for antiseptic cap holder assemblies;

**FIG. 63** is a cross-sectional view taken along line A-A of **FIG. 62**;

**FIG. 64** is a side view of the strip package; and,

**FIG. 65** is an enlarged view taken at location "B" of **FIG. 63**.

### DETAILED DESCRIPTION OF THE INVENTION

While this invention is susceptible of embodiment in many different forms, there is shown in the drawings, and will be described herein in detail, specific embodiments thereof with the understanding that the present disclosure is to be considered as an exemplification of the principles of the invention and is not intended to limit the invention to the specific embodiments illustrated.

**FIGS. 1 and 2** show an antiseptic cap equipped plunger and syringe barrel assembly **10** having an antiseptic cap equipped plunger (or piston) assembly **12** and a syringe barrel **14**. The barrel **14** has a side wall **16** defining a chamber **18** and the barrel has a proximal end **20** and a distal end **22**. The proximal end **20** has an opening **23** to the chamber **18** and a flange **24** extending radially outwardly from the wall **16**. The flange **24** has upper and lower surfaces **26, 28** and provides gripping surfaces for a user of the assembly **10**. The distal end **22** of the barrel **14** has an end wall **30** and an elongate tip **32** extending distally therefrom and having a passageway **34** therethrough and in fluid communication with the chamber **18**. The distal end wall **30**, in one preferred form of the invention, is generally conically shaped and, as is well known in the art, can have a locking luer collar **35** concentrically surrounding the tip **32** and having a set of threads **37** on an inside surface thereof. The luer collar **35** allows for attaching a needle or a cannula to barrel **14** and for docking the assembly **10** to mating threads located on other devices such as valves, injection sites and other medical access devices well known in the art. **FIG. 1** shows the syringe assembly proximate an access site **38** having a valve **39** controlling access to a lumen of a tubing **41**.

In one preferred form of the invention the chamber **18** of the syringe assembly **10** will be filled with a locking solution or a flush solution for use with an indwelling, central venous catheter. The manner of using a locking or flush solution with a catheter is well known in the art. Suitable locking or flushing solutions will be set forth below. The flush or locking solution is injected into a fluid access site of the catheter to clean and disinfect the catheter and can be withdrawn from the catheter or allowed to remain in an end portion of the catheter to serve as a barrier to the ingress of pathogens and contaminants.

The antiseptic cap plunger assembly **12** has an elongate shaft **40**, a proximal end **42** and a distal end **44**. The elongate shaft **40**, in one preferred form of the invention, is generally cruciform in cross-sectional shape. A stopper or piston **50** is connected to the distal end **44** of the plunger **40**. The piston **50** is dimensioned such that when inserted into

the syringe barrel chamber **18** an outer circumferential surface of the piston **50** is in fluid-tight engagement with an inner surface **54** of the syringe barrel. The piston assembly **14** when moved proximally (or when being withdrawn) can draw fluid into the chamber and when moved distally (or when inserted into the syringe chamber) can drive fluid out of the chamber. **FIG. 1** shows the piston assembly **12** partially inserted into the syringe chamber and **FIG. 2** shows the piston assembly fully inserted into the syringe chamber to deliver fluid to the tubing **41**.

A housing **60** is located at the proximal end **42** of the plunger assembly **12** and has a wall **62** defining a chamber **64** having an open end **66** which can be sealed by any suitable structure or material such as a cap or by a foil material **68**. An optional annular flange **70** extends radially outwardly from the wall **62** and provides a surface upon which the sealing structure can be attached.

**FIG. 5** shows a cap assembly **80** proximate the chamber **64** of the housing **60** and **FIG. 6** shows the cap assembly **80** positioned within the chamber **64**. In one preferred form of the invention, the cap assembly **80** has a cap **82** having a wall **83** defining a chamber **84** containing an absorbent material **86** such as a sponge. The sponge **86**, in a preferred form of the invention, is wetted or soaked with an agent such as an antiseptic, anticoagulant or antimicrobial (“antiseptic solution”) and can be selected from the locking and flushing solutions set forth below or the antiseptic solutions set forth below. The cap **82** has an interior surface **87** with a set of threads **88** for mating with a set of threads on the access site **38**.

**FIGS. 7** and **8** show the cap assembly **80** sealed with a foil material or lid stock material **68** which can be attached to the flange **70** by any suitable method such as by adhesives or by conductive or inductive heat sealing techniques. **FIG. 7** shows the antiseptic cap piston assembly **12** and **FIG. 8** shows the antiseptic cap equipped piston assembly **12** inserted into the chamber of the syringe barrel **14** to define the antiseptic cap equipped piston and syringe barrel assembly **10**.

**FIGS. 3** and **4** show one possible method for utilizing the cap assembly **80** by docking with the access device **38**. **FIG. 3** shows the lid stock **68** peeled away from the flange **70** and **FIG. 4** shows docking the antiseptic cap assembly **80** to the valve **39**. The syringe barrel is rotated clockwise or counterclockwise to engage the threads **88** of the antiseptic cap assembly **80** with the threads of the access site **38**. After engagement, the syringe barrel **14** will be moved away from the access site **38** and the antiseptic cap

assembly **80** will slide outward from the housing **60** and remain docked to the access site **38**. The antiseptic cap assembly **80** can remain docked to the valve **39** of the access site **38** for any suitable period of time from a few minutes to numerous hours. When the antiseptic cap assembly **80** is docked to the valve **39** the tubing or catheter **41** is sealed to block the ingress into the catheter of pathogens and contaminants and a portion of the access site **38** is exposed to the antiseptic material in the sponge **86**.

It is desirable that during the rotation of the syringe barrel that the antiseptic cap assembly **80** does not rotate with respect to the housing and/or optionally that the plunger assembly **12** does not rotate with respect to the syringe barrel **14** until the threads **88** of the antiseptic cap can fully engaged the threads of the access site **38**. The present invention provides a mechanism associated with the assembly **10** for preventing the rotation of the antiseptic cap assembly **80** with respect to the plunger assembly **12** and more preferably a mechanism on either the plunger assembly or on the antiseptic cap **80** to prevent relative rotational movement between the antiseptic cap **80** and the plunger assembly **12**. In an even more preferred form of the invention, the mechanism for preventing relative rotation of the antiseptic cap assembly **80** with respect to the plunger assembly **12** has mating portions on both parts that when assembled cooperatively engage one another to prevent relative rotation. It is also contemplated that a separate mechanism, device or member could be used to lock the two parts together to achieve this purpose.

If a user grasps the assembly **10** by the antiseptic cap and plunger assembly **12** then the interlocking structures between the plunger assembly **12** and the syringe barrel **14** would not necessarily be needed. Accordingly, **FIGS. 5, 9-11** show exemplary structures for locking the antiseptic cap assembly **80** inside the housing **60** so that these parts rotate together and one part does not rotate in a direction or at a rate different from that of the other part. Further, **FIGS. 15-18** show exemplary structures for interlocking the antiseptic cap plunger assembly **12** with the syringe barrel **14**.

In one preferred form of the invention the housing **60** will have a feature or structure that forms an interference fit with an external surface **83** of the antiseptic cap **80**. Even more preferable, an internal surface **63** of the side wall **62** of the housing **60** will have a feature or structure to form an interference fit with a portion of the antiseptic cap assembly **80**. In another preferred form of the invention the antiseptic cap assembly **80** will have a feature to form an interference fit with the housing **60** and even more

preferably the outer surface **83** of the antiseptic cap **80** will have a feature to contact the inner surface **63** of the housing side wall **62**.

In another preferred form of the invention the plunger housing **60** and the cap assembly **80** each will have a feature or structure that cooperatively engage one another to prevent relative rotation of the cap assembly **80** and the housing **60**. **FIG. 5** shows one preferred form of the invention having a plurality of circumferentially spaced and axially extending ribs **100** on the internal surface **63** of the housing side wall **62** (internal ribs **100**) for engaging the wall **83** of the antiseptic cap **82** to lock the cap assembly **80** in place to prevent rotation of the cap assembly **80** when positioned inside the housing **60**. In a preferred form of the invention, the internal ribs **100** extend from a bottom wall **102** up to an intermediate height of the housing sidewall **62**. In a preferred form of the invention the internal ribs **100** will have a height roughly equal to a height of the cap **82**. A plurality of internal slots **108** are defined between each set of adjacent internal ribs **100**. The internal ribs **100**, in a preferred form of the invention, will have a width that tapers inwardly from proximate the bottom wall **102** to a top **104** of the internal ribs **100** so that the width of the internal ribs decrease from a bottom **106** of a rib to the top **104** of the rib. Also, it is preferable that the top of the internal ribs **100** have a generally arcuate profile to act as a lead-in during insertion of the antiseptic cap assembly **80** into the housing **60**. In a preferred form of the invention, the internal ribs **100** will terminate short of a top **113** of the housing sidewall **62** to define an annular gap **111** between the top of the rib **104** and the top **113**. Also, extending radially inwardly from the internal surface **63** of the cap **82** is a detent **109** positioned proximate a top portion **113** of the side wall **62**.

The antiseptic cap **82** has a plurality of circumferentially spaced and axially extending ribs **120** extending along an external surface **121** of the cap **83** of cap **82** (external ribs **120**). In one preferred form of the invention external ribs **120** extend between annular flange **123** at a proximal end **124** of the cap **82** to a position proximate a distal end **126** of the cap **82**. The external ribs **120** are dimensioned for engaging a portion of the interior wall surface **63** of the housing **62** to prevent relative rotation of the cap assembly **80** and the plunger assembly **12**. Spacing between the external ribs define a plurality of external slots **122** between each adjacent pair of external ribs **120**. When the cap **82** is positioned within the chamber **64** (**FIGS. 9** and **11**) each of the external ribs **120** are positioned within an internal slot **108** and each of the internal ribs **100** are positioned within an external slot **122** to lock together these parts to assure that the cap rotates in the

same direction as the plunger rod assembly **12**. **FIGS. 6** and **11** also show that when the cap **82** is positioned within the housing **60**, the detent **109** contacts the annular flange **123** to hold the cap assembly **80** in the plunger housing chamber **64** to prevent or resist inadvertent dropping of the cap assembly **80** from the housing chamber **64** prior to docking of the cap assembly **80** with the access site **38**.

**FIGS. 12-14** show several embodiments of gripping surfaces on the housing **60** (with lid stock **68** removed) to facilitate use of the assembly **10** or the plunger assembly **12**. **FIG. 12** shows axially extending and circumferentially spaced protuberances **130** on an outer surface of the wall **62**. The protuberances **130** can have numerous different cross-sectional shapes including circular, polygonal, oval and irregular and, in a preferred form of the invention, extend from the flange **70** to a bottom of the housing.

**FIG. 13** shows a housing **60** that has no flange **70** and has protuberances **130** on the wall **62** extending substantially the entire height of the housing **60**. **FIG. 14** shows a housing **60** where the outer surface of the wall **62** is relatively smooth but has a series of circumferentially spaced and axially extending protuberances **130** on a circumferential edge of the flange **70**.

As with the cap and plunger assembly rotational locking features or structures, the optional plunger assembly **12** and syringe barrel **14** locking feature or structure can be positioned alone on the plunger assembly **12**, or alone on the syringe barrel **14** or have cooperating structures on both the plunger assembly **12** and the syringe barrel **14**. It is also contemplated that a separate mechanism, device or member could be used to lock the two parts together to achieve this purpose.

**FIGS. 15-18** show various embodiments for the optional feature of locking the plunger assembly **12** from rotational motion with respect to the syringe barrel **14**. In one embodiment shown in **FIGS. 15-17** and **21** a wing **150** extending axially along an outside surface of the housing side wall **62** engages a tooth **152** positioned on an interior surface of the syringe barrel **14** at its proximal end **20**. More preferably, the plunger assembly **12** will have more than one wing **150** with each wing being circumferentially spaced from the other. In an even more preferred form of the invention the plunger assembly will have four wings **150** spaced 90 degrees from one another. Also, in a more preferred form of the invention, the syringe barrel **14** will have a plurality of circumferentially spaced teeth **152**. When the plunger assembly **12** is nearly fully inserted into the syringe barrel **14** each of the

wings **150** will extend into a tooth **152** to prevent rotation of the plunger assembly **12** with respect to the syringe barrel **14**.

**FIG. 18** shows another embodiment of a locking feature to prevent rotation of the plunger assembly **12** with respect to the syringe barrel **14** and also prevents relative translational motion of the parts. In this embodiment an annular protuberance **160** positioned on an interior surface of the syringe barrel at its proximal end **20** engages an annular detent **162** on an outside surface of the plunger rod.

**FIGS. 19** and **20** show an antiseptic cap equipped plunger assembly **12** and non-refluxing syringe assembly **170**. Non-refluxing syringes are well known in the art and there are numerous methodologies for reducing reflux while accessing the access site of a central venous catheter. In this embodiment the annular flange **70** of the plunger assembly **12** abuts the flange **24** of the syringe barrel prior to the piston **50** contacting an interior surface of the syringe distal end wall **30**.

It is contemplated that the antiseptic cap assembly **80** of the present invention need not be coupled or combined with a plunger or a syringe barrel. **FIGS. 22a,b** show a stand-alone antiseptic cap assembly **200** having three circumferentially spaced ribs **120** for grasping by the hand of a user of the cap assembly. **FIG. 22a** shows the cap **82** without an absorbent material **86** and **FIG. 22b** shows the cap with an absorbent material. The cap **200** can be used for the same purposes of the cap assembly **80** described above but will be used by hand. All other features of the cap **200** are essentially the same as described above with the exception that the cap **200** does not have to be dimensioned to fit within a chamber carried by a syringe plunger. **FIGS. 23** and **24** show varying frequency of ribs **120** and varying shapes and sizes.

**FIG. 25** shows the cap **200** proximate the access site **38** and **FIGS. 26** and **27** show the cap **200** docked to the access site **38**.

A suitable absorbent material **86** includes medical grade materials capable of storing and releasing an antiseptic liquid, or liquid having other medical purposes, and includes materials such as sponges, rupturable capsules and other materials or devices capable of serving this purpose. Suitable sponges can include any sponge suitable for use for medical purposes and can be naturally occurring or synthetic. The sponges can be die cut into suitable shapes or can be molded into the desired shape. It is desirable that the sponge **86** be attached to the antiseptic cap **82** to prevent the sponge **86** from inadvertently falling out of the cap **82**. **FIG. 28** shows the sponge **86** is captured between an annular

wall **202** and a disc **204** attached to the cap **82** by any suitable method such as ultrasonic or vibrational welding or other techniques well known in the art.

**FIGS. 29** and **30** show a variation on the cap assembly **200** of **FIG. 28**. In this embodiment, the sponge is retained in the cap **82** with a plastic sheet **206** heat welded to the cap. In one preferred form of the invention the sponge is attached by an adhesive or by other method to form an assembly which is then attached to the cap.

**FIGS. 31 a,b** show the cap **200** having a coaxially disposed and axially extending actuating post **220** circumferentially surrounded by a sponge **86** having a centrally positioned hole to fit over the post **220**. **FIG. 31a** shows the cap **200** in initial engagement with the access site **38** and **FIG. 31b** shows the cap threaded onto the access site **38** and the actuating post opens the valve **39** and antiseptic fluid is allowed to flow into the valve.

**FIGS. 32-34** show varying shaped sponges that, in one preferred form of the invention, were molded into various desirable shapes. The sponge of **FIG. 34** has a central opening **230** to facilitate attaching the sponge to the cap and to filling the sponge with antiseptic, anticoagulant or other suitable fluids set forth above. **FIG. 35** shows the cap having a centrally disposed energy director **231**, an ultrasonic welder **232** being brought into cooperative engagement with the sponge on a side of the sponge opposite the energy director **231**. By applying ultrasonic energy the energy director **231** melts and attaches the sponge to the cap. **FIG. 36** shows a filling device **240**, having a lumen **242** and a dispensing head **244** in fluid communication with a source of antiseptic, anticoagulant or the like for dispensing a metered amount of such fluid into the interior portion of the sponge.

**FIG. 37** shows an alternative embodiment of the antiseptic cap **200** where the sponge is replaced by an antiseptic coating on the actuating post **220**.

**FIG. 38** shows the antiseptic cap **200** positioned in a blister pack **233** prior to sealing the blister pack.

**FIG. 39** shows an antiseptic cap **300** with a thread cover **302**. The thread cover **302** can be part of any of the antiseptic caps discussed herein. The thread cover **302** is made of a deformable material capable of flexing upon application of moderate force applied by hand. In one preferred form of the invention the thread cover **302** is made from a polymeric containing material and more preferably a polymeric material having a modulus of elasticity of less than 20,000 psi. In another preferred form of the invention the polymeric material will be an elastomer or plastomer or like material. The thread cover



**302** enhances the connection between the antiseptic cap **300** and a device such as a valve or other access devices **38**. The thread cover **302** provides a physical barrier to the ingress of pathogens, dust or other contaminants through the mating threads of the antiseptic cap **300** and the access device or valve to which it is docked. The thread cover **302** also serves to retain antiseptic fluids from the antiseptic cap **300** from leaking out through the threads. The thread cover can be made a part of the antiseptic cap **300** using techniques well known in the art such as overmolding, or by attaching as a separate part using welding techniques such as heat conductive welding, heat induction welding, vibrational welding, stretch or friction fit, or by using a suitable adhesive.

The thread cover **302** can provide a universal fit to most commercially available valves, connectors and access devices, or the thread cover **302** can be customized to dock with a particular access device.

**FIG. 39** shows, as is described above, the antiseptic cap **300** has an annular wall **305** having a first end **306** and a second end **320** with the first end having a greater diametrical dimension than the second end. The annular wall defines a central chamber **322** having an open end **323**. In one preferred form of the invention, the chamber **322** will have a sponge **86** positioned therein as shown in **FIG. 5** and **6** above, although it is not shown in **FIG. 39**. The thread cover **302** is shown attached by an optional bonding layer **304** to the first end **306** of the annular wall **305**. The thread cover **302** has a first leg **308** and a second leg **310**. The first leg **308** extends parallel to the annular wall **305** and the second leg **310** extends radially inwardly from the annular wall **305** in a direction transverse to the first leg **308** and across a portion of the open end **323** and defines a central opening **312**, having a reduced diameter when compared to the open end **323**, into the chamber **322**. The second leg **310** terminates at a distal end **330** with a rounded outer surface **332**.

**FIG. 40** shows an alternative embodiment of the antiseptic cap **300** having the thread cover **302** having both the first and second legs **308**, **310** attached to the first end **306** of the annular wall **305** through bonding layers **304 a,b**. A top surface **340** of the first end **306** is shown having the same thickness or diametrical dimension as the remainder of the first end but it is contemplated the top surface could have a radially extending flange **123** as shown in **FIG. 5**.

**FIG. 41** shows an alternative embodiment of the antiseptic cap **300** that differs from the antiseptic cap shown in **FIGS. 39** and **40** by not including a counterbore **336**

shown in these figures. The counterbore **336** provides a chamber of reduced diameter and, therefore, will form a tighter fit with access devices with a more narrow outer diameter when compared to the cap shown in **FIG. 41** which does not include the counterbore. This is just one example of the modifications that can be made to the geometry of the antiseptic cap to enhance the connection between the cap and an access site.

**FIGS. 42a,b** show front and back views of the antiseptic cap **300** with the thread cover **302** connected to a Cardinal SMART SITE access site **350**. **FIGS. 43 a,b** are perspective front and back views of the antiseptic cap without the thread cover **302** connected to the Cardinal SMART SITE access site.

**FIGS. 44a,b** are perspective front and back views of the antiseptic cap **300** with the thread cover **302** connected to a Hospira (ICU) C1000 Clave access device **352**. **FIGS. 45a,b** are perspective front and back views of the antiseptic cap, without a thread cover **302**, connected to the Hospira (ICU) C1000 Clave access device.

**FIGS. 46a,b** are perspective front and back views of the antiseptic cap **300** with the thread cover **302** connected to a B. Braun ULTRASITE access device **354**. **FIGS. 47a,b** are perspective front and back views of the antiseptic cap without the thread cover **302** connected to the B. Braun ULTRASITE access device.

**FIGS. 48a,b** are perspective front and back views of the antiseptic cap with the thread cover **302** connected to a Rymed INVISION PLUS access device; **356**. **FIGS. 49a,b** are perspective front and back views of the antiseptic cap without the thread cover **302** connected to a Rymed INVISION PLUS access device.

**FIGS. 50-52** show various embodiments of the thread cover **302**. **FIG. 50** differs from **FIG. 51** in that the second leg **310** extends farther across the opening of the chamber in **FIG. 51** than shown in **FIG. 50**. **FIG. 52** shows another embodiment of the thread cover **302** having a segmented second leg **310a,b**. This embodiment may be desirable to provide a more effective seal for certain access devices.

**FIG. 53** shows an exploded view of an alternative embodiment **400** of the syringe barrel assemblies **10**, discussed above, incorporating a cap holder **402** into the system of parts. Thus, the alternative assembly and system **400** has an antiseptic cap and cap holder equipped plunger assembly **12'**, a syringe barrel **14**, an antiseptic cap **82** (shown with an optional thread cover **302**), an absorbent material **86**, and peelable lid stock **68**. **FIG. 54** shows an exploded view of an antiseptic cap holder assembly **404** including the cap holder **402** with the antiseptic cap assembly **80** positioned within a chamber **406** of the cap holder

**402.** This embodiment **400** allows for the separate manufacture, assembly, and sterilization of the assembly **400** from the plunger assembly and the syringe barrel.

The cap holder **402** has a proximal and distal ends **408**, **410**, and an inner wall surface **412** and an outer wall surface **414**, an opening **416** into the chamber **406**, and a radially outwardly extending flange **418** circumjacent the opening **416** and extending from the proximal end **408** of the cap holder **402**. The cap holder **402** will also have an optional bottom wall **419**.

In a preferred form of the invention, the cap holder **402** or the antiseptic cap **82** will have a structure, element or the like that prevents the relative rotation of the cap holder **402** and the antiseptic cap **82** until the antiseptic cap assembly **80** is securely docked to the access device **38**. Also, in a preferred form of the invention the cap holder **402** or the plunger assembly **12'** will have a structure, element or the like for preventing the relative rotation of the cap holder **402** and the plunger assembly **12'** until the antiseptic cap assembly **80** is securely docked to the access device **38**. Any of the anti-rotation devices discussed above to stop the rotation of the antiseptic cap assembly **80** with the plunger assembly **12** would be suitable for, these purposes. Also, it is contemplated the devices discussed above in reference to **FIGS. 15-21** to prevent the relative rotation of the plunger assembly **12** and the syringe barrel **14** could be incorporated into this embodiment **400**.

**FIG. 53** shows the inner wall surface **412** of the cap holder **402** carries the internal ribs **100** and the internal slots **108** that interact with the external ribs and external slots **120**, **122** of the cap **82** as is described above with respect to **FIG. 5**. These structures prevent or resist the relative rotation of the cap holder **402** with respect to the antiseptic cap assembly **80**. The term "ribs" referred to herein are structures that are raised or extend outward from a surface. The term "slots" refer to structures that extend below a surface or is defined between two ribs and is at a lower level than the ribs.

**FIG. 53** also shows an interlocking structure for preventing the relative rotation of the cap holder **402**, or the cap holder assembly **404**, with respect to the plunger assembly **12'**. The outer wall surface **414** has a plurality of circumferentially spaced and axially extending ribs **420** defining slots **424** between each pair of adjacent ribs. In a preferred form of the invention, the ribs **420** are generally triangular in shape having a base portion **426** and an apex portion **428**. The slots **424** are oppositely-oriented triangularly shaped areas having slot base portions **430** extending between two adjacent rib apex portions **428** and slot apex portions **432** separating adjacent rib base portions **426**. On the internal wall

surface **63** of the plunger chamber **64** are similarly shaped plunger ribs **434** and plunger slots **436**. The ribs **420** are dimensioned to fit within the plunger slots **436** and the slots **424** are dimensioned to fit over and receive the plunger ribs **434**. Thus, when the cap holder **402** or the cap holder assembly **404** is inserted in the plunger chamber **64** the cap holder ribs **420** are interdigitated with the plunger ribs **434** to prevent or resist the relative rotation of the cap holder **402**, or cap holder assembly **404**, with respect to the plunger assembly **12'**.

In yet another preferred form of the invention, the cap holder **402**, the cap holder assembly **404** or the plunger assembly **12'** will have a structure, element or the like that resists the relative axial movement of these parts when the cap holder **402** or the cap holder assembly **404** is positioned fully within the plunger assembly **12'**. In one preferred form of the invention the cap holder **402** has an annular protuberance **440** that is dimensioned to fit within an annular groove **442** on the inner wall surface **414** of the cap holder and preferably extends in line with the base portions of the plunger ribs **434**. A second locking structure is provided having a plurality of teeth **450** which extend axially outward from the outer wall surface **414** of the cap holder and are positioned in slots **424**. In a preferred form of the invention the teeth extend axially outwardly to a height beyond the height of the ribs **434**. The teeth **450** can be positioned in one or more of the slots or in each of the slots **424** or in alternating slots or, as is shown, circumferentially spaced 90° from one another. The teeth **450** preferably are positioned at an intermediate portion, between the base and the apex, of a slot **424**. The teeth **450** are dimensioned to fit within a segmented annular groove **452** that extends circumferentially about the inner surface **412** crossing through the plunger ribs **434** at an intermediate portion, between the base and the apex, of the plunger ribs **434**.

**FIGS. 56a,b,c** respectively show the assembly **400** in a ready-for-use position, docked position, and used position. The assembly **400** is used in essentially the same fashion as described above with respect to **FIGS. 3** and **4** except that when the assembly **400** is in the used position the cap holder **402** remains in the plunger assembly **12'**.

The syringe barrel and plunger can be fabricated from any material suitable for its purpose and includes glass and polymeric material. Suitable polymeric materials include, but are not limited to, homopolymers, copolymers and terpolymers formed from monomers such as olefins, cyclic olefins, amides, esters, and ethers. The polymeric material may be a blend of more than one polymeric material and can be a monolayer structure or a

multilayer structure. In one preferred form of the invention the syringe barrel and the plunger are injection molded from a polypropylene material.

**FIGS. 59-61** show a third embodiment **500** of an antiseptic cap equipped syringe plunger and barrel assembly with the antiseptic cap assembly **80** and lid stock **68** removed for clarity. The third embodiment **500** provides for retrofitting an antiseptic cap assembly **502** to a standard plunger **504**. The antiseptic cap **502** has a first generally cylindrical outer wall **506** having a proximal end **508** and a distal end **510**. The proximal end **508** is removably or fixedly attached to a button **512** of the plunger **504**. The proximal end has an opening **514** dimensioned to fit about the button **512** and has a member for attaching to the button. In one preferred form of the invention, the attaching member includes a plurality of circumferentially spaced, and axially inwardly directed tabs **516** extending from an inner wall surface **518** and the tabs engage a lower surface of the button **512** to attach the antiseptic cap assembly **502** to the plunger **504**.

The distal end of the antiseptic cap **502** has a top annular flange **520** extending radially inwardly from the first cylindrical wall **506** and defines a generally circular opening **522**. A second cylindrical wall **524** extends axially downwardly from the top annular flange **520** and is coaxially disposed within the first cylindrical wall **506**. When the antiseptic cap **502** is attached to the plunger button **512** a bottom peripheral edge of the second cylindrical wall **524** will abut a top surface of the plunger button **512** thereby capturing, by oppositely directed axially forces, the plunger button **512** between the tabs **516** and the second cylindrical wall. It is contemplated, however, that a second set of tabs could be provided spaced axially away from the first set of tabs and the piston button **512** could be trapped between the two sets of tabs. Further, it is contemplated other attaching means could be used that are well known in the art and the attaching member shown is merely exemplary.

The second cylindrical wall **524** defines a chamber as is shown in greater detail in **FIG. 5** above with the ribs and slots as described for engaging the antiseptic cap assembly **80** to prevent relative rotational movement and to resist relative axial movement of the parts when the antiseptic cap assembly **80** is fully inserted into the chamber. Further, it is contemplated adapting the plunger and syringe as described above to prevent or resist the relative rotational movement of the plunger with respect to the barrel.

The piston **50** can be formed from any suitable material including a polymeric material or a silicone material. The stopper can be selected from a material with a desired

durometer so that reflux is reduced when the stopper engages an inner surface of the distal end wall of the syringe barrel.

**FIGS. 62-65** show a strip package **600** having a plurality of antiseptic cap holder assemblies **602**, attached to a single cover, or strip **604**. Each of the cap holder assemblies **602** includes a cap holder **602a** and an antiseptic cap **602b**. The antiseptic cap **602b** could be any cap discussed herein, such as the antiseptic cap **300** (**FIG. 39**) with a thread cover **302**. Any number of disinfectant filled devices as discussed herein, such as the antiseptic cap holder assemblies **602**, can be attached to one common cover or strip **604** of non-permeable (or very low permeable) film or foil laminate. The cover or strip **604** can be sealed to the holder **602a** of each disinfectant cap **602b**, or it could include a double seal, with one seal **606** between the strip **604** and the holder **602a**, and another seal **608** between the strip **604** and the cap **602b**, e.g., sealed to the thread cover. The seal(s) could be between the strip **604** and the holder **602a**. The double seal can provide an extra barrier to keep the disinfectant from evaporating from the cap **602b** which provides improved shelf life. Each device still remains individually sterile, but a plurality of devices is chained to one another for convenience through the use of the common strip **604**. The strip package **600** can include one or more holes, such as a die cut hole or holes, or a hanger **610** for hanging the strip **604** of product on a convenient hanger such as an IV pole. The strip **604** may have notches and/or perforations and/or scores that allow the user to tear an individual unit off for future use and still retain the individual sterile barrier of the unit.

The strip **604** could be thermally bonded to the holder **602a** and/or the cap **602b** using standard heat sealing technology, such as impulse, induction, conduction, radiant, or other heat sealing techniques. Alternatively, the strip **604** could be attached to the holder **602a** and/or the cap **602b** utilizing an adhesive bond or by a suitable mechanical or friction connection, such as a snap-fit. The caps **602b** are peelable from the strip **604** such that the peel force is less than the strength of the hanger **610**. The peel force could generally be less than two pounds of force to start peeling, and less than one pound of force to continue peeling. The strip **604** could be made of any suitable material, such as foil, plastic, a laminate, etc. In one aspect, the strip **604** could be made of a foil material having a thickness of approximately 1 to 2 mil. The strip **604** could have a thick foil with a top coat of PET (polyethylene terephthalate), such as 48-gauge PET, then a polymer coat such as PDX which could be white, and a bottom coat of a peelable sealing layer, such as Allegro B, manufactured by Rollprint Packaging Products, Inc. The sealing layer could form an

adhesive bond that could be peelable. The caps **602b** could be attached to the strip **604** by induction heating of the foil, which melts the peelable sealing layer to adhere it to the caps **602b**.

The holder **602a** prevents contamination of the cap **602b** when handled by virtue of the flange of the holder **602a** which extends out from the holder **602a** and acts as a guard against contact of the top of the cap **602b** by an user.

Suitable locking and flush solutions include a lower alcohol selected from ethanol, propanol and butanol. The locking solution can be a single lower alcohol or a blend of lower alcohols.

Suitable locking solutions can also include a lower alcohol with an antimicrobial and or an anticoagulant. Suitable locking solutions can contain at least one lower alcohol in a range from 1% to 99% by volume and at least one other anti-microbial and/or anti-coagulant compound in a range from 1% to 99% by volume. The lower alcohol will usually be in aqueous solution, typically at 1% to 99% by volume, usually from 5% to 95% by volume. The at least one other anti-microbial is selected from the group consisting of taurolidine and triclosan, and the at least one anti-coagulant is selected from the group consisting of riboflavin, sodium citrate, ethylene diamine tetraacetic acid, and citric acid.

In one preferred form of the invention, the syringe assembly **10** will be pre-filled with one of the locking solutions and will be packaged by a manufacture and shipped to a health care provider. A cannula or needle will be attached to the distal end of the barrel and placed into fluid communication with the fluid access site of an indwelling central venous catheter. The flush solution will be injected into the catheter to clean or lock the catheter. Afterwards, the cap assembly **80** will be removed from the plunger **17** and the cap will be docked to the fluid access site of the catheter.

#### Citrate salt containing antiseptic solutions

In one form, the antiseptic is a solution a citrate salt and in another form of the invention the citrate salt solution is a hypertonic solution. The term hypertonic is used herein to refer to a fluid having an osmotic concentration and a density greater than the osmotic concentration and density of the blood of the patient. The antiseptic solution preferably comprises a citrate salt with a concentration range, in weight percent, of from about 1.5% to about 50% with an osmolality of about 300 to about 6400 mOsm. More preferably, the antiseptic solution comprises citrate salt in a concentration range of from

about 10% to about 40%, yet more preferably, in a concentration range of from about 20% to about 30%.

In a preferred embodiment, the antiseptic solution is prepared to have a pH lower than that of the pH of the patient's blood. The citrate salt solution may be prepared to have a pH lower than about 6.5, more preferably, from about 4.5 to about 6.5. Also, the citrate salt solution can include pharmaceutically acceptable agents such as sodium chloride and sodium heparin. The citrate salt solution can also include a variety of other antibacterial, antimicrobial and anticoagulant agents such as gentamicin, vancomycin, and mixtures of these agents. Additional anticoagulant agents include, for example heparin, urokinase, tissue plasminogen activation (tPA) and mixtures of these agents.

By "pharmaceutically acceptable," it is meant that the citrate salt solution and the included salts and other additives which are, within the scope of sound medical judgment, suitable for use in contact with tissues of humans and lower animals without undue toxicity, irritation, and allergic response. It is also typically necessary that a composition be sterilized to reduce the risk of infection.

#### Antibacterial agent containing antiseptic solutions

An antimicrobial agent containing antiseptic solution of the present invention may contain at least one alcohol, at least one antimicrobial agent and at least one chelator and/or anticoagulant. Various antimicrobial substances as disclosed herein and that are well known to one of ordinary skill in the art may be combined with the locking solution in order to inhibit infection. The antimicrobial locking solution of the present invention may be used for filling or flushing a medical device such as an indwelling device such as an implanted catheter. Other medical devices that are contemplated for use in the present invention are disclosed herein.

In another preferred form of the invention, the antiseptic agent can contain antibacterial agents such as those classified as aminoglycosides, beta lactams, quinolones or fluoroquinolones, macrolides, sulfonamides, sulfamethoxazoles, tetracyclines, treptogramins, oxazolidinones (such as linezolid), clindamycins, lincomycins, rifamycins, glycopeptides, polymyxins, lipo-peptide antibiotics, as well as pharmacologically acceptable sodium salts, pharmacologically acceptable calcium salts, pharmacologically acceptable potassium salts, lipid formulations, derivatives and/or analogs of the above.

The aminoglycosides are bactericidal antibiotics that bind to the 30S ribosome and inhibit bacterial protein synthesis. They are typically active against aerobic gram-negative



*bacilli* and *staphylococci*. Exemplary aminoglycosides that may be used in some specific aspects of the invention include amikacin, kanamycin, gentamicin, tobramycin, or netilmicin.

Suitable beta lactams are selected from a class of antibacterials that inhibit bacterial cell wall synthesis. A majority of the clinically useful beta-lactams belong to either the penicillin group (penam) or cephalosporin (cephem) groups. The beta-lactams also include the carbapenems (e.g., imipenem), and monobactams (e.g., aztreonam). Inhibitors of beta-lactamase such as clavulanic acid and its derivatives are also included in this category.

Non-limiting examples of the penicillin group of antibiotics that may be used in the solutions of the present invention include amoxicillin, ampicillin, benzathine penicillin G, carbenicillin, cloxacillin, dicloxacillin, piperacillin, or ticarcillin, etc. Examples of cephalosporins include ceftiofur, ceftiofur sodium, cefazolin, cefaclor, ceftibuten, ceftizoxime, cefoperazone, cefuroxime, cefprozil, ceftazidime, cefotaxime, cefadroxil, cephalixin, cefamandole, cefepime, cefdinir, ceftriaxone, cefixime, cefpodoximeproxetil, cephalirin, cefoxitin, cefotetan etc. Other examples of beta lactams include mipenem or meropenem which are extremely active parenteral antibiotics with a spectrum against almost all gram-positive and gram-negative organisms, both aerobic and anaerobic and to which *Enterococci*, *B. fragilis*, and *P. aeruginosa* are particularly susceptible.

Suitable beta lactamase inhibitors include clavulanate, sulbactam, or tazobactam. In some aspects of the present invention, the antibacterial solutions may comprise a combination of at least one beta lactam and at least one beta lactamase inhibitor.

Macrolide antibiotics are another class of bacteriostatic agents that bind to the 50S subunit of ribosomes and inhibit bacterial protein synthesis. These drugs are active against aerobic and anaerobic gram-positive cocci, with the exception of enterococci, and against gramnegative anaerobes. Exemplary macrolides include erythromycin, azithromycin, clarithromycin.

Quinolones and fluoroquinolones typically function by their ability to inhibit the activity of DNA gyrase. Examples include nalidixic acid, cinoxacin, trovafloxacin, ofloxacin, levofloxacin, grepafloxacin, trovafloxacin, sparfloxacin, norfloxacin, ciprofloxacin, moxifloxacin and gatifloxacin.

Sulphonamides are synthetic bacteriostatic antibiotics with a wide spectrum against most gram-positive and many gram-negative organisms. These drugs inhibit multiplication of bacteria by acting as competitive inhibitors of p-aminobenzoic acid in the

folic acid metabolism cycle. Examples include mafenide, sulfisoxazole, sulfamethoxazole, and sulfadiazine.

The tetracycline group of antibiotics include tetracycline derivatives such as tigecycline which is an investigational new drug (IND), minocycline, doxycycline or demeclocycline and analogs such as anhydrotetracycline, chlorotetracycline, or epioxytetracycline.

Suitable streptogramin class of antibacterial agents include quinupristin, dalfopristin or the combination of two streptogramins.

Drugs of the rifamycin class typically inhibit DNA-dependent RNA polymerase, leading to suppression of RNA synthesis and have a very broad spectrum of activity against most gram-positive and gram-negative bacteria including *Pseudomonas aeruginosa* and *Mycobacterium* species. An exemplary rifamycin is rifampicin.

Other antibacterial drugs are glycopeptides such as vancomycin, teicoplanin and derivatives thereof. Yet other antibacterial drugs are the polymyxins which are exemplified by colistin.

In addition to these several other antibacterial agents such as prestinomycin, chloramphenicol, trimethoprim, fusidic acid, metronidazole, bacitracin, spectinomycin, nitrofurantoin, daptomycin or other leptoptides, oritavancin, dalbavancin, ramoplanin, ketolide etc. may be used in preparing the antiseptic solutions described herein. Of these, metronidazole is active only against protozoa, such as *Giardia lamblia*, *Entamoeba histolytica* and *Trichomonas vaginalis*, and strictly anaerobic bacteria. Spectinomycin, is a bacteriostatic antibiotic that binds to the 30S subunit of the ribosome, thus inhibiting bacterial protein synthesis and nitrofurantoin is used orally for the treatment or prophylaxis of UTI as it is active against *Escherichia coli*, *Klebsiella-Enterobacter* species, *staphylococci*, and *enterococci*.

In other embodiments, the antimicrobial agent is an antifungal agent. Some exemplary classes of antifungal agents include imidazoles or triazoles such as clotrimazole, miconazole, ketoconazole, econazole, butoconazole, omoconazole, oxiconazole, terconazole, itraconazole, fluconazole, voriconazole, posaconazole, ravuconazole or flutrimazole; the polyene antifungals such as amphotericin B, liposomal amphoterecin B, natamycin, nystatin and nystatin lipid formulations; the cell wall active cyclic lipopeptide antifungals, including the echinocandins such as caspofungin, micafungin, anidulfungin, cilofungin; LY121019; LY303366; the allylamine group of antifungals such as terbinafine.

Yet other non-limiting examples of antifungal agents include naftifine, tolnaftate, mediocidin, candicidin, trichomycin, hamycin, aurefungin, ascosin, ayfattin, azacolutin, trichomycin, levorin, heptamycin, candimycin, griseofulvin, BF-796, MTCH 24, BTG-137586, pradimicins (MNS 18184), benanomycin; ambisome; nikkomycin Z; flucytosine, or perimycin.

In another preferred form of the invention, the antimicrobial agent is an antiviral agent. Non-limiting examples of antiviral agents include cidofovir, amantadine, rimantadine, acyclovir, gancyclovir, pencyclovir, famciclovir, foscarnet, ribavirin, or valcyclovir. In some forms of the invention the antimicrobial agent is an innate immune peptide or proteins. Some exemplary classes of innate peptides or proteins are transferrins, lactoferrins, defensins, phospholipases, lysozyme, cathelicidins, serprocidins, bacteriocidal permeability increasing proteins, amphipathic alpha helical peptides, and other synthetic antimicrobial proteins.

In other embodiments of the invention, the antimicrobial agent is an antiseptic agent. Several antiseptic agents are known in the art and these include a taurinamide derivative, a phenol, a quaternary ammonium surfactant, a chlorine-containing agent, a quinaldinium, a lactone, a dye, a thiosemicarbazone, a quinone, a carbamate, urea, salicylamide, carbanilide, a guanide, an amidine, an imidazoline biocide, acetic acid, benzoic acid, sorbic acid, propionic acid, boric acid, dehydroacetic acid, sulfurous acid, vanillic acid, esters of p-hydroxybenzoic acid, isopropanol, propylene glycol, benzyl alcohol, chlorobutanol, phenylethyl alcohol, 2-bromo-2-nitropropan-1,3-diol, formaldehyde, glutaraldehyde, calcium hypochlorite, potassium hypochlorite, sodium hypochlorite, iodine (in various solvents), povidone-iodine, hexamethylenetetramine, noxythiolin, 1-(3-chloroallyl)-3,5,7-triazolo-1-azoniaadamantane chloride, taurolidine, taurultam, N(5-nitro-2-furfurylidene)-1-amino-hydantoin, 5-nitro-2-furaldehyde semicarbazone, 3,4,4'-trichlorocarbanilide, 3,4,5-tribromosalicylanilide, 3-trifluoromethyl-4,4'-dichlorocarbanilide, 8-hydroxyquinoline, 1-cyclopropyl-6-fluoro-1,4-dihydro-4-oxo-7-(1-piperazinyl)-3-quinolinecarboxylic acid, 1,4-dihydro-1-ethyl-6-fluoro-4-oxo-7-(1-piperazinyl)-3-quinolinecarboxylic acid, hydrogen peroxide, peracetic acid, phenol, sodium oxychlorosene, parachlorometaxyleneol, 2,4,4'-trichloro-2'-hydroxydiphenol, thymol, chlorhexidine, benzalkonium chloride, cetylpyridinium chloride, silver sulfadiazine, or silver nitrate.

In another preferred form of the invention, the antiseptic solution includes a basic reagent and a dye. The basic reagent may be a guanidium compound, a biguanide, a bipyridine, a phenoxide antiseptic, an alkyl oxide, an aryl oxide, a thiol, a halide, an aliphatic amine, or an aromatic amine. In some specific aspects, the basic reagent is a guanidium compound. Non-limiting examples of guanidium compounds include chlorhexidine, alexidine, hexamidine. In other specific embodiments, the basic reagent is a bipyridine. One example of a bipyridine is octenidine. In yet other aspects, the basic reagent is a phenoxide antiseptic.

The dye may be a triarylmethane dye, a monoazo dye, a diazo dye, an indigoid dye, a xanthene dye, an anthraquinone dye, a quinoline dye, an FD&C dye. Non-limiting examples of triarylmethane dye include gentian violet, crystal violet, ethyl violet, or brilliant green. Exemplary monoazo dyes include FD&C Yellow No. 5, or FD&C Yellow No. 6. Other non-limiting examples of FD&C dye include Blue No. 1 or Green No. 3. One non-limiting example of diazo dyes is D&C Red No. 17. An example of an indigoid dye is FD&C Blue No. 2. An example of a xanthene dye is FD&C Red No. 3; of an anthraquinone dye is D&C Green No. 6; and of a quinoline dye is D&C Yellow No. 1.

Other examples of antiseptics that may be used to the solutions of the invention are the phenoxide antiseptics such as clofoctol, chloroxylenol or triclosan. Still other antiseptic agents that may be used to prepare the antimicrobial solutions of the invention are gendine, genlenol, genlosan, or genfoctol.

One of skill in the art will appreciate that one can use one or more of the antimicrobial agents including one or more antibacterial agent, and/or one or more antifungal agent, and/or one or more antiviral agent, and/or one or more antiseptic agent, and/or combinations thereof.

A wide variety of chelator agents are contemplated as useful in preparing the antiseptic solutions of the invention. This includes chelators such as EDTA free acid, EDTA 2Na, EDTA 3Na, EDTA 4Na, EDTA 2K, EDTA 2Li, EDTA 2NH<sub>4</sub>, EDTA 3K, Ba(II)-EDTA, Ca(II)-EDTA, Co(II)-EDTA, Cu(II)-EDTA, Dy(III)-EDTA, Eu(III)-EDTA, Fe(III)-EDTA, In(III)-EDTA, La(III)-EDTA, CyDTA, DHEG, diethylenetriamine penta acetic acid (DTPA), DTPA-OH, EDDA, EDDP, EDDPO, EDTA-OH, EDTPO, EGTA, HBED, HDTA, HIDA, IDA, MethylEDTA, NTA, NTP, NTPO, O-Bistren, TTHA, EGTA, DMSA, deferoxamine, dimercaprol, zinc citrate, a combination of bismuth and citrate, penicillamine, succimer or Etidronate. It is contemplated that any chelator which binds

barium, calcium, cerium, cobalt, copper, iron, magnesium, manganese, nickel, strontium, or zinc will be acceptable for use in the present invention.

Alternatively, one may use at least one anticoagulant such as heparin, hirudin, EGTA, EDTA, urokinase, streptokinase, hydrogen peroxide etc., in the preparation of the antimicrobial solutions of the invention.

In addition to the alcohols set forth above, a variety of alcohols are contemplated as useful in the preparation of the instant antiseptic solution, and include any antimicrobially active alcohol. Non-limiting examples of alcohols include ethanol, methanol, isopropanol, propylene glycol, benzyl alcohol, chlorobutanol, phenylethyl alcohol, and the like.

One of skill in the art will appreciate that the solutions of the instant invention can comprise various combinations of at least one alcohol, at least one antimicrobial agent, and at least one chelator/anticoagulant. In some specific embodiments, the solution of the invention comprises at least one alcohol, at least one tetracycline and at least one chelator/anticoagulant. In a specific aspect, such an antimicrobial solution comprises ethanol, at least one tetracycline and EDTA or heparin.

In other specific aspects, such a solution comprises ethanol, minocycline and EDTA or heparin. In one embodiment of this aspect, the concentration of minocycline is 0.001 mg/ml to 100 mg/ml. In another embodiment, the concentration of minocycline is about 3 mg/ml. In another aspect, the concentration of EDTA is in the range of 10-100 mg/ml. In one embodiment of this aspect, the concentration of EDTA is about 30 mg/ml.

In another preferred form of the invention, the antiseptic solution includes a pharmacologically acceptable sodium salt, a pharmacologically acceptable calcium salt, a pharmacologically acceptable potassium salt and about one milligram per milliliter polyhexamethylene biguanide hydrochloride in an aqueous admixture. Additionally, the solution of the invention may also contain a pharmacologically acceptable salt of lactic acid.

#### Salt containing antiseptic solutions

One preferred antiseptic solution includes a pharmacologically acceptable sodium salt such as sodium chloride or the like in a concentration of between about 820 mg to about 900 mg, a pharmacologically acceptable calcium salt, such as calcium chloride dihydrate or the like in a concentration between about 30.0 mg to about 36.0 mg, a pharmacologically acceptable potassium salt, such as potassium chloride or the like in a concentration between about 28.5 to about 31.5 mg and about one milligram per milliliter

polyhexamethylene biguanide hydrochloride in an aqueous admixture with one hundred milliliters of water for injection U.S.P. For particular applications, the solution of the invention may also include sodium lactate in a concentration between about 290 mg and about 330 mg in the one hundred milliliter aqueous admixture.

#### Photo-oxidant solutions

In another preferred form of the present invention, the antiseptic solution contains an anticoagulant and a photo-oxidant. In certain embodiments, a photo-oxidant is selected that has an antiseptic effect. As used herein, the term "photo-oxidant" is intended to refer to a compound (usually an organic dye) that has photo-oxidation properties, in which the compound exhibits an increased oxidizing potential upon exposure to radiant energy such as light. The term "photooxidant" also refers to a composition that releases one or more electrons when struck by light.

In one preferred aspect of the invention, the photo-oxidant is methylene blue, which advantageously provides antibiotic and antifungal activity, and also provides a color to make the antiseptic solution clearly identifiable. In addition to methylene blue, other photo-oxidants may include Rose Bengal, hypericin, methylene violet, proflavine, rivanol, acriflavine, toluidine blue, trypan blue, neutral red, a variety of other dyes or mixtures thereof. Therefore, in alternate aspects of the invention, one or more alternative photo-oxidants, preferably a colored photo-oxidant is used in accordance with the invention in place of methylene blue.

#### Enhanced viscosity solutions

In another preferred form of the invention, the antiseptic solution includes a low viscosity antibacterial agent mixed with a viscosity increasing agent. Examples of antibacterial agents which may be used, in addition to those described above, comprise alcohols, chlorhexidine, Chlorpactin, iodine, taurolin, citric acid, and soluble citric acid salts, particularly sodium citrate, optionally mixed with water.

Suitable viscosity increasing agents include Carbopol, starch, methylcellulose, carboxypolyethylene, carboxymethyl cellulose, hydroxypropylcellulose, or the like. Carbopol is a cross-linked polyacrylic acid based polymer sold by Noveon, Inc. It is preferably neutralized to about pH 7 with a base material such as tetrahydroxypropyl ethylene diamine, triethanolamine, or sodium hydroxide. Derivatives of starch may also be used, such as hydroxyethylstarch, hydroxypropylstarch, or starch having bonded organic acid ester groups, to improve compatibility with antibacterial agents such as

alcohols, for example, ethanol or isopropanol. Such ester groups may be the reaction product of two to twelve carbon organic acids with the starch, for example. Also, the elevated viscosity antiseptic solution may be created by the use of a fat emulsion, or other dispersions in water/alcohol of glycerol mono or di esters of fatty acids, or fatty acid esters of other polyols such as sugars having one or more bonded fatty acid groups per molecule. Analogous compounds with ether linkages may also be used.

Also, other materials such as alginic acid, with or without calcium citrate may be used, or polyvinyl alcohol, with or without borax, povidone, polyethylene glycol alginate, sodium alginate, and/or tragacanth. If desired, the fluid of this invention may also contain an effective amount of an antithrombogenic agent such as heparin, and a diluent such as water, along with other desired ingredients.

In one preferred form of the invention, the antiseptic solution contains a mixture of isopropyl alcohol and neutralized Carbopol, with other optional ingredients being present such as water, antithrombogenic agents such as heparin, and the like. Preferably, about 0.4 to 2 weight percent of Carbopol is present. Citric acid may also be present as an antibacterial agent, either with or as a substitute for another anti-bacterial agent such as isopropyl alcohol or ethanol.

In another embodiment, the antiseptic solution is a gel of an isopropyl alcohol, optionally with up to about 30 weight percent water, and about 2.2 weight percent hydroxypropylcellulose, to form a high viscosity antiseptic solution.

In yet another preferred form of the invention, the antiseptic solution contains carbohydrates and/or glucose degradation products. Suitable carbohydrates are chosen from the group of glucose and/or fructose. Suitable degradation products include 3-deoxyglucosone (3-DG), acetaldehyde, formaldehyde, glyoxal, methylglyoxal, 5-hydroxymethyl-2-furaldehyde (5-HMF), 2-furaldehyde, and 3,4-dideoxyglucosone-3-ene (3,4-DGE).

Other suitable agents to be used in this embodiment of the antiseptic solution includes substances having anticoagulatory properties i.e., inhibitors of the coagulation cascade such as heparin of standard and low molecular weight, fractionated heparin, synthetic inhibitors in the coagulation cascade, Futhan as a broad protease inhibitor, complexing and chelating substances such as citrate, EDTA, EGTA, substances and mixtures used for preservation of blood products (platelets or plasma), CDPA (citrate, sodium phosphate, dextrose, adenine), synthetic or natural thrombin inhibitor substances.

Other suitable additives include fucosidan, riboflavin, vitamin E, alphatocopherol, folic acid and amino acids. Furthermore, antiinflammatory compounds and drugs could also be used, e.g. cortison, mycophenolic acid (MPA) and derivates thereof, sirolimus, tacrolimus and cyclosporin, diclofenac, etc.

Inhibitory peptides can also be used in the antiseptic solution such as defensins, (dermacidine), and others. Radicals, such as reactive oxygene species, NO-releasing systems or nitric oxide (NO), and peroxyxynitrite may also be used. A buffer composition may also be included in the antiseptic solution, and in one preferred form of the invention, the buffer contains lactate, bicarbonate, pyruvate, ethyl pyruvate and citric acid in combination and mixtures including adjustment of pH by acetic acid, hydrochloric acid or sulphuric acid. Furthermore, viscosity enhancing additives may be added, such as lipids or lipidic substances (also to get water insoluble vitamins or complexes into solution), nutrients in high concentration density gradient e.g. aminoacid containing fluids, polyglucose, Icodextrin, pectine, hydroxyethyl starch (HES), alginate, hyaluronic acid, etc. Taurolidine antiseptic solutions and gels

The antiseptic solutions of the present invention can include Taurolidine and/or Taurultam to prevent clotting and Biofilm formation or the elements can be combined with other antimicrobial agents. One embodiment of the present invention is a gel with thixotropic properties to keep the solution inside the antiseptic cap and not spill out during the time interval between uses. This is accomplished by making a hydrogel matrix as a drug delivery vehicle containing a biocompatible antimicrobial agent alone or with another active agent, which may be useful for particular purposes. The hydrogel matrix is biocompatible and, biodegradable in the bloodstream. The matrix can be a hydrogel (e.g., pectin, gelatin, etc), a protein (e.g., collagen, hemoglobin, etc), a colloidal substance (e.g., serum albumin etc.), an emulsion or other adjuvant. Preferably, the matrix shall have structural integrity and be thixotropic. Thixotropy is a property, which is exhibited by certain gels. It is a property characterized by a solid or semisolid substance that when shaken, stirred or subject to high shear forces becomes fluid like and can flow and then returns to the semisolid state when the forces and/movement are stopped. Alternatively, the gel could have the properties similar to that of the colloidal dispersion which resists movement, or flow until a high shear force is imparted to the fluid and then it flows easily.

Other ingredients may be added to the gel matrix to provide further functional benefit. The preferred antimicrobial is Taurolidine, which can be added to the matrix as a



micro particle powder, or encapsulated in liposomes, microspheres, or nanospheres. It should be appreciated that numerous active agents and drugs can be added to the thixotropic gel including sterileants, lysing agents (such as Urokinase), imaging enhancers, catheter surface modifiers, antibiotics and antimicrobial chemicals.

A hydrogel comprises a three-dimensional molecular network containing large quantities of water giving them good biocompatibility with material consistency that is soft solid-like with high diffusive properties to gases, chemicals and proteins. Suitable hydrogels include natural polymers including serum albumin, collagen, or alginates, polyvinyl alcohol, poly (ethylene oxide) or poly (hydroxyethylene) and polyelectrolytes, such as poly(acrylic acid), poly(styrene sulfonate), and carboxymethylcellulose (CMC).

One preferred form of the antiseptic solution includes Taurolidine with Salicylic acid or Sodium Salicylate in an aqueous solvent. Salicylic Acid and Sodium Salicylate are drugs that have been used with antibiotic locks in catheters to enhance the biocidal action of the antibiotic alone and to inhibit the attachment of microbes to surfaces. This last attribute is especially important because the initiation of a Biofilm expression and growth require that the individual bacteria must first attach themselves to the underlying surface. By stopping attachment, Biofilm formation is blocked.

Sodium salicylate has been demonstrated to have remarkable antibacterial activity, including the ability to enhance the activities of certain antibiotics. This drug inhibits adherence, growth and Biofilm formation.

EDTA containing antiseptic solutions

In one preferred antiseptic solution of the present invention provides antimicrobial, antifungal, anti-viral and anti-amoebic properties and may also serve as an anti-coagulant. Specified salts and compositions of ethylene diamine tetraacetic acid (EDTA) ( $C_{10}H_{12}N_2Na_4O_8$ ) are used at specified concentrations and pH levels.

The EDTA formulations of the present invention are safe for human administration and are biocompatible and non-corrosive. They may also have anticoagulant properties and are thus useful for preventing and/or treating a variety of catheter-related infections. In one embodiment, antiseptic solutions of the present invention have at least four, and preferably at least five, of the following properties: anticoagulant properties; inhibitory and/or bactericidal activity against a broad spectrum of bacteria in a planktonic form; inhibitory and/or fungicidal activity against a spectrum of fungal pathogens; inhibitory and/or bactericidal activity against a broad spectrum of bacteria in a sessile form;

inhibitory activity against protozoan infections; inhibitory activity against Acanthamoeba infections; safe and biocompatible, at least in modest volumes, in contact with a patient; safe and biocompatible, at least in modest volumes, in a patient's bloodstream; and safe and compatible with industrial objects and surfaces. The antiseptic solution can have a pH higher than physiological pH such as a pH of  $>8.0$ , or at a pH  $>8.5$ , or at a pH  $>9$ , or at a pH  $>9.5$ .

In another preferred form of the invention, the antiseptic solution contain a sodium EDTA salt (or combination of sodium salts) in solution at a pH in the range between 8.5 and 12.5 and, in another embodiment, at a pH of between 9.5 and 11.5 and, in yet another embodiment, at a pH of between 10.5 and 11.5.

When used herein, the term "EDTA salt" may refer to a single salt, such as a di-sodium or tri-sodium or tetra-sodium salt, or another EDTA salt form, or it may refer to a combination of such salts. The composition of EDTA salt(s) depends both on the EDTA salts used to formulate the composition, and on the pH of the composition. For antiseptic solutions of the present invention consisting of sodium EDTA salt(s), and at the desired pH ranges (specified above), the sodium EDTA salts are predominantly present in both the tri-sodium and tetra-sodium salt forms.

In one embodiment, the antiseptic solution contains a combination of at least the tri-sodium and tetra-sodium salts of EDTA, and more preferably solutions containing at least 10% of the EDTA in the composition is present in the tetra-sodium salt form. In yet another embodiment, at least 50% and, more preferably at least 60%, of the EDTA in the composition is present in the tri-sodium salt form.

EDTA solutions of the present invention are preferably provided in a sterile and non-pyrogenic form and may be packaged in any convenient fashion. The compositions may be prepared under sterile, aseptic conditions, or they may be sterilized following preparation and/or packaging using any of a variety of suitable sterilization techniques.

Formulation and production of antiseptic compositions of the present invention is generally straightforward. In one embodiment, desired antiseptic solutions of the present invention are formulated by dissolving one or more EDTA salt(s) in an aqueous solvent, such as purified water, to the desired concentration and adjusting the pH of the EDTA salt solution to the desired pH. The antiseptic solution may then be sterilized using conventional means, such as autoclaving, UV irradiation, filtration and/or ultrafiltration, and other means. The preferred osmolarity range for EDTA solutions is from 240-500

mOsM/Kg, more preferably from 300-420 mOsm/Kg. The solutions are preferably formulated using USP materials.

Antiseptic solutions containing sodium salts of EDTA other than tri- and tetra-sodium salts, such as di-sodium EDTA, is also contemplated. For example di-sodium EDTA solutions can be used but such solutions have a lower pH in solution than the desired pH range of compositions of the present invention but, upon pH adjustment to the desired range using a pH adjustment material, such as sodium hydroxide, sodium acetate, and other well-known pH adjustment agents, EDTA solutions prepared using di-sodium salts are converted to the preferred combination di- and/or tri- and/or tetra-sodium salt EDTA solutions of the present invention. Thus, different forms and combinations of EDTA salts may be used in the preparation of EDTA compositions of the present invention, provided that the pH of the composition is adjusted to the desired pH range prior to use. In one embodiment, antiseptic compositions consisting of a mixture of primarily tri- and tetra-sodium EDTA is provided by dissolving di-sodium EDTA in an aqueous solution, 3%-5% on a weight/volume basis, and adding sodium hydroxide in a volume and/or concentration sufficient to provide the desired pH of >8.5 and <12.0.

#### Antibacterial enzyme containing antiseptic solutions

“Antibacterial enzyme” refers to any proteolytic, pore-forming, degradative or inhibitory enzyme that kills or damages a bacterial species or particular strain thereof. The result may be achieved by damaging the cell wall of the bacteria, disrupting cell membranes associated with the cell wall or within the bacteria, inhibiting protein synthesis within the bacteria, disrupting the sugar backbone, or by any other mechanism attributed to a peptide or protein considered by those skilled in the art to be an antibacterial enzyme. The enzyme may be a natural, wild-type enzyme, modified by conventional techniques, conjugated to other molecules, recombinantly expressed, or synthetically constructed.

One example of an antibacterial enzyme is lysostaphin. Lysostaphin is important because it is effective in the treatment of staphylococci and biofilms formed therefrom. “Lysostaphin,” and “lysostaphin analogues” are defined as including lysostaphin (wild type), any lysostaphin mutant or variant, any recombinant, or related enzyme (analogue) or any synthetic version or fragment of lysostaphin (whether synthetic or otherwise) that retains the proteolytic ability, in vivo and in vitro, to cleave the cross-linked polyglycine bridges in the cell wall peptidoglycan of staphylococci. The enzymes may be generated by post-translational processing of the protein (either by enzymes present in a producer strain

or by means of enzymes or reagents introduced at any stage of the process) or by mutation of the structural gene. Mutations may include site deletion, insertion, domain removal and replacement mutations.

The lysostaphin may be synthetically constructed, expressed in mammalian cells, insects, bacteria, yeast, reptiles or fungi, recombinantly expressed from a cell culture or higher recombinant species such as a mouse, or otherwise. This would include the activity-retaining synthetic construction including synthetic peptides and polypeptides or recombinant expression of portions of the lysostaphin enzyme responsible for its activity against staphylococci as part of a larger protein or peptide, include chimeric proteins, containing the active sites of one or more other antibacterial enzymes that are effective either against staphylococci or other biofilmforming bacteria species.

The antibacterial enzymes may also be coated on the surface of the devices described herein by immersion of the device in a solution of the enzyme for a length of time sufficient to form a biofilm-formation inhibiting coating of the enzyme on the susceptible surface. Even the most minimal concentration of enzyme will confer some protection. Typically, a concentration of from about 10  $\mu\text{g/ml}$  to about 100  $\text{mg/ml}$  can be used. With device surfaces, the coatings may also be formed by covalent attachment of the enzyme thereto.

#### Antiseptic coatings

It is contemplated that the devices described herein can be coated with an antiseptic coating by any suitable technique such as immersion of the part into an antiseptic solution, by spray coating the part with the antiseptic solution, by blending the antiseptic solution or material into the polymeric material used to fabricate the device.

In one preferred form of the invention, a quantity of physiological, antimicrobial metal compound is added to the resin for direct molding of an article. Physiological, antimicrobial metals are meant to include the precious metals, such as silver, gold and platinum, and copper and zinc. Physiological, antimicrobial metal compounds used herein include oxides and salts of preferably silver and also gold, for example: silver acetate, silver benzoate, silver carbonate, silver citrate, silver chloride, silver iodide, silver nitrate, silver oxide, silver sulfa diazine, silver sulfate, gold chloride and gold oxide. Platinum compounds such as chloroplatinic acid or its salts (e.g., sodium and calcium chloroplatinate) may also be used. Also, compounds of copper and zinc may be used, for example: oxides and salts of copper and zinc such as those indicated above for silver.

Single physiological, antimicrobial metal compounds or combinations of physiological, antimicrobial metal compounds may be used.

Preferred physiological, antimicrobial metal compounds used in this invention are silver acetate, silver oxide, silver sulfate, gold chloride and a combination of silver oxide and gold chloride. The particles of the silver compounds are sufficiently able to be extracted to form a zone of inhibition to prevent and kill bacteria growth.

In another preferred form of the invention the devices herein are impregnated with triclosan and silver compounds or triclosan and chlorhexidine.

It is to be understood that the foregoing description is not intended to limit the spirit or scope of the disclosure. It will be understood that the aspects of the disclosure described herein are merely exemplary and that a person skilled in the art may make many variations and modification without departing from the spirit and scope of the disclosure. All such variations and modifications, including those discussed above, are intended to be included within the scope of the disclosure.

CLAIMS

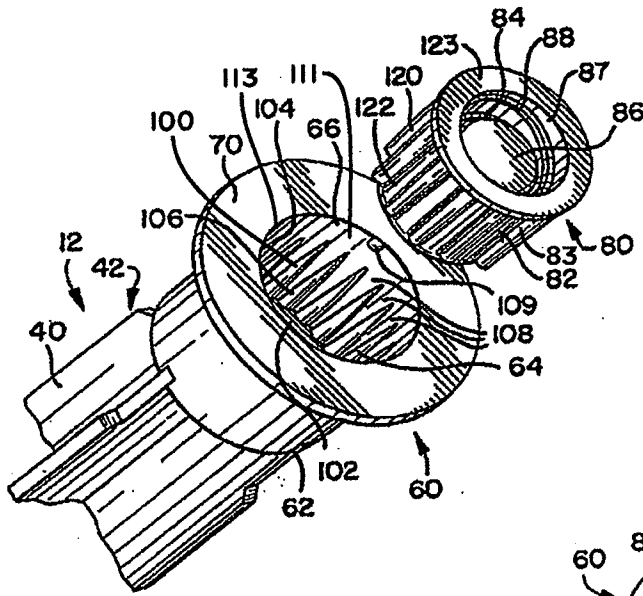
What is claimed is:

1. A package for a cap assembly comprising:  
an outer seal engaged to a cap holder; and an inner seal arranged substantially concentric with respect to said outer seal, said inner seal engaged to an antiseptic cap positioned in the cap holder.
2. The package of Claim 1, further comprising a strip including at least two of said outer seals and at least two of said inner seals.
3. The package of Claim 2, wherein said strip includes a hole.
4. The package of Claim 1, wherein an unsealed portion is located between said outer seal and said inner seal.
5. A strip package comprising:  
at least two cap assemblies, each of said at least two cap assemblies including a cap holder and an antiseptic cap positioned in said cap holder, said antiseptic cap including a sidewall defining a chamber and an antiseptic substance within said chamber; and  
a strip extending over said at least two cap assemblies, said strip including a first seal engaged to said cap holder and a second seal engaged to said antiseptic cap.
6. The strip package of Claim 5, wherein each of said at least two cap assemblies is individually removable from said strip.
7. The strip package of Claim 6, wherein said first seal is between said strip and said cap holder, and said second seal is between said strip and said antiseptic cap.
8. The strip package of Claim 7, wherein said strip includes a hole.
9. The strip package of Claim 8, wherein an unsealed portion is located between said first seal and said second seal.
10. A strip package comprising:  
at least two cap assemblies, each of said at least two cap assemblies including a cap holder and an antiseptic cap positioned in said cap holder, said antiseptic cap including a sidewall defining a chamber and an antiseptic substance within said chamber; and  
a strip extending over said at least two cap assemblies, said strip including a seal engaged to said cap holder.
11. The strip package of Claim 10, wherein each of said at least two cap assemblies is individually removable from said strip.

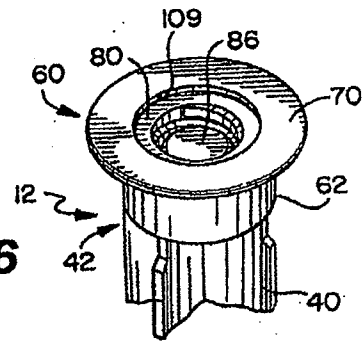
12. The strip package of Claim 11, wherein said strip includes a second seal engaged to said antiseptic cap.
13. The strip package of Claim 12, wherein said seal is between said strip and said cap holder, and said second seal is between said strip and said antiseptic cap.
14. The strip package of Claim 13, wherein said strip includes a hole.
15. The strip package of Claim 14, wherein an unsealed portion is located between said seal and said second seal.



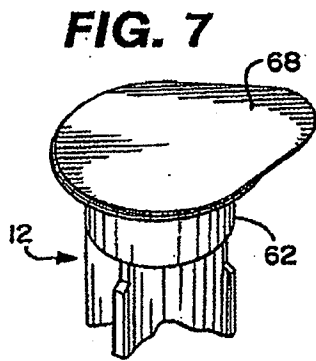




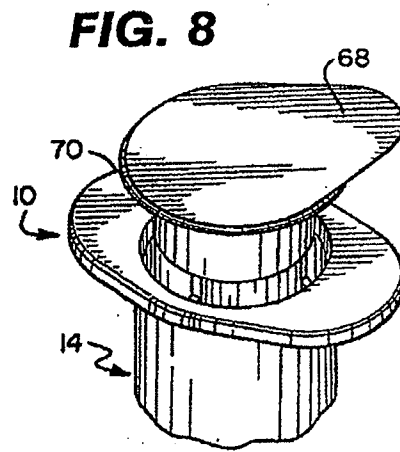
**FIG. 5**



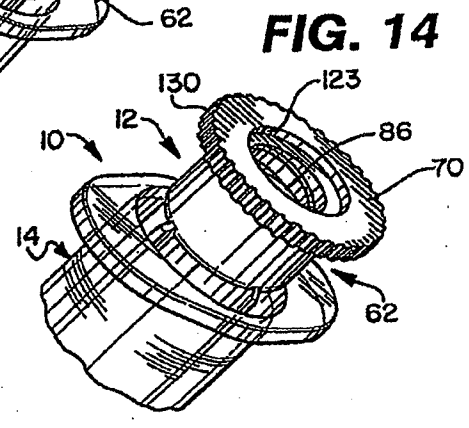
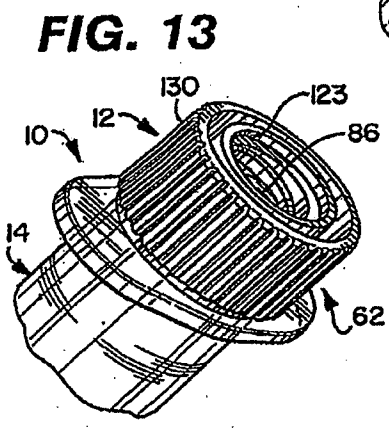
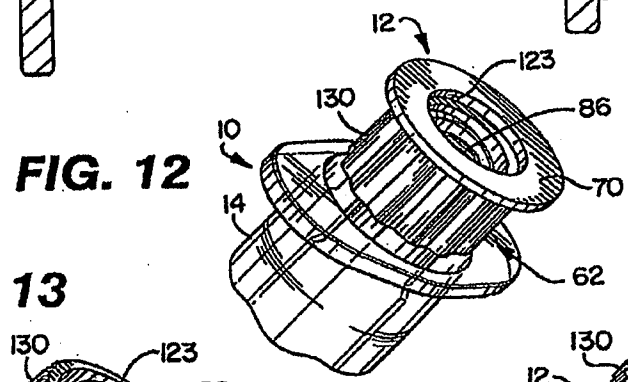
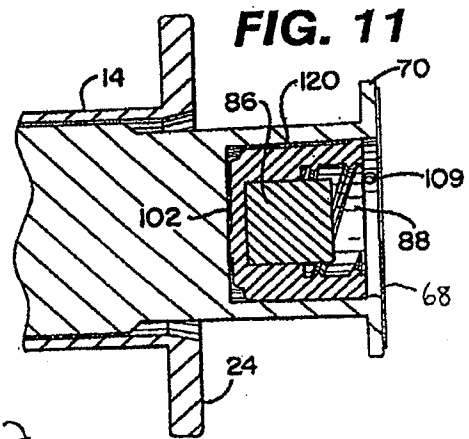
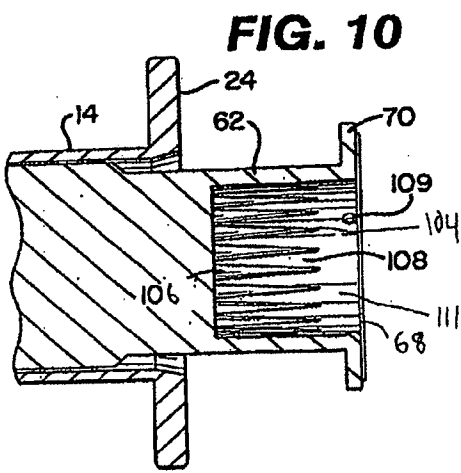
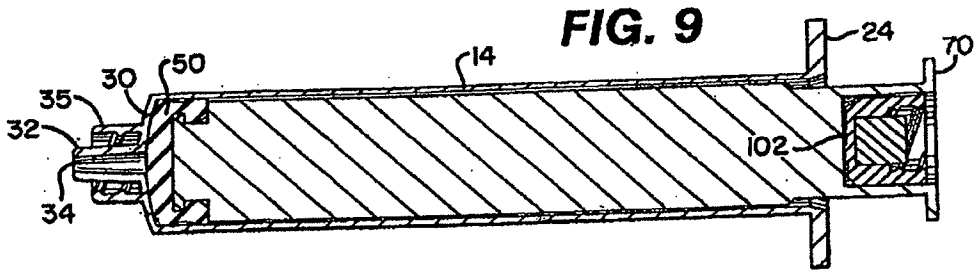
**FIG. 6**

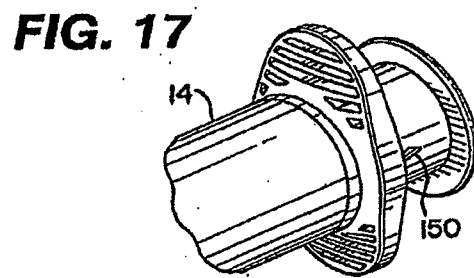
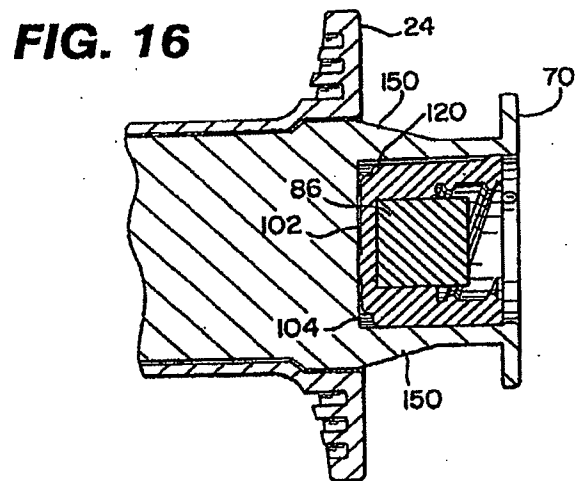
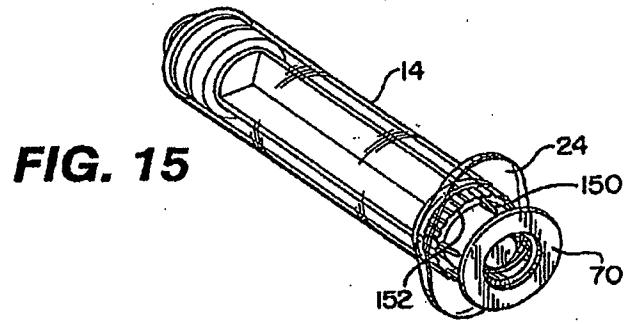


**FIG. 7**

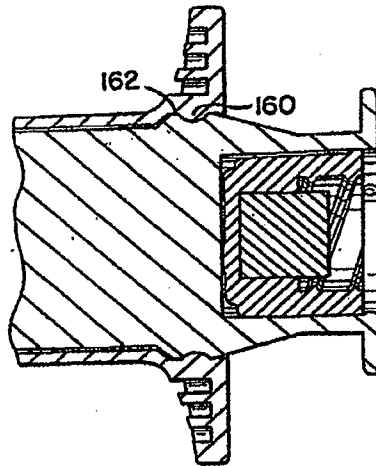


**FIG. 8**

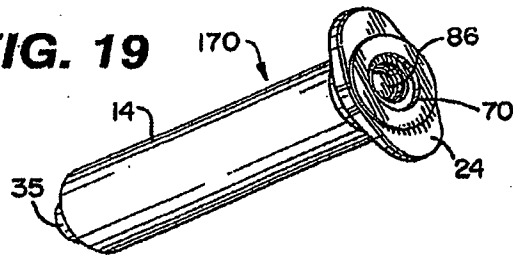




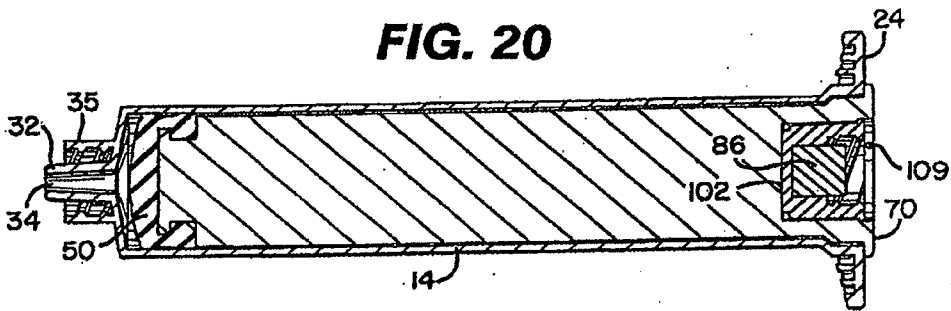
**FIG. 18**



**FIG. 19**



**FIG. 20**



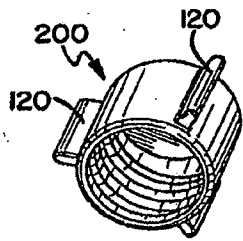
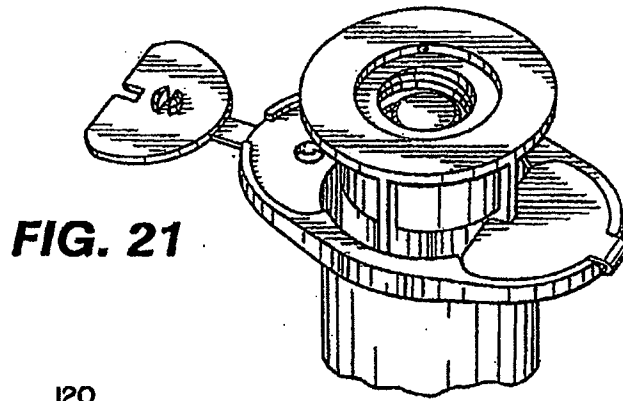


FIG. 22a

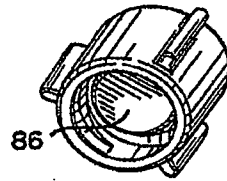


FIG. 22b

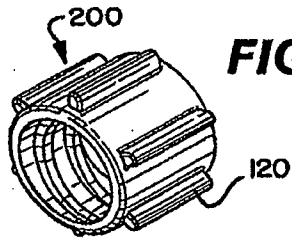


FIG. 23

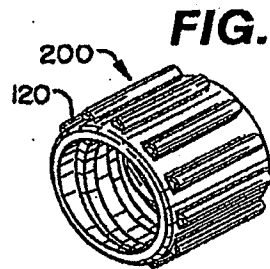


FIG. 24

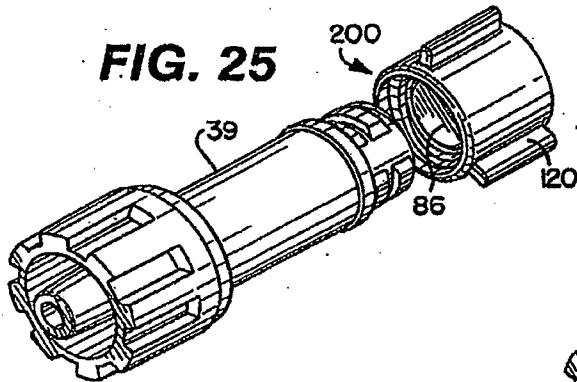


FIG. 25

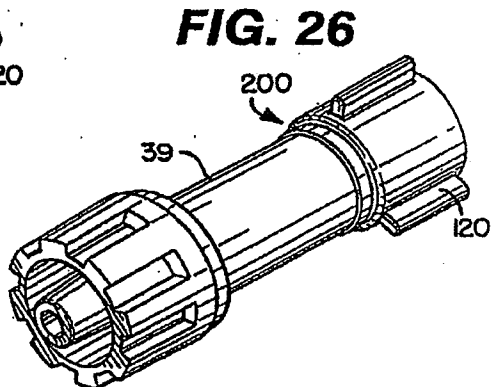
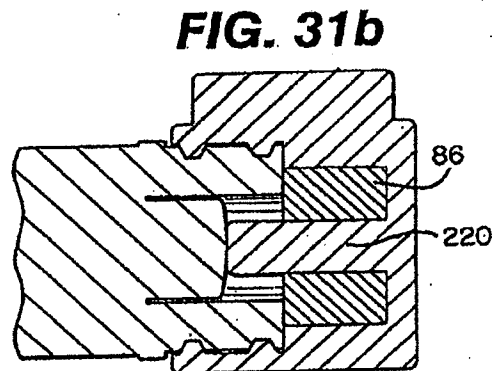
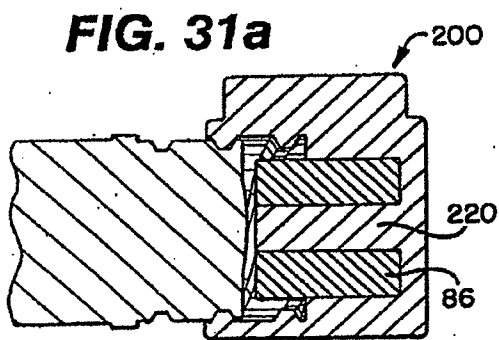
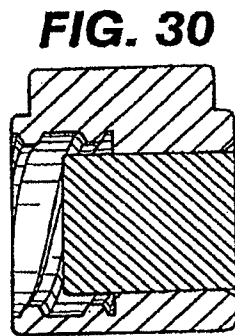
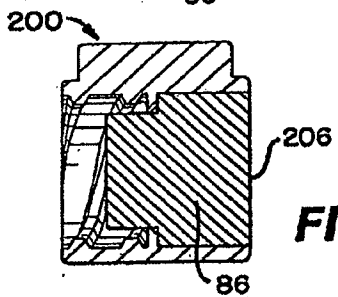
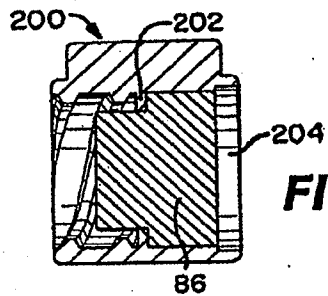
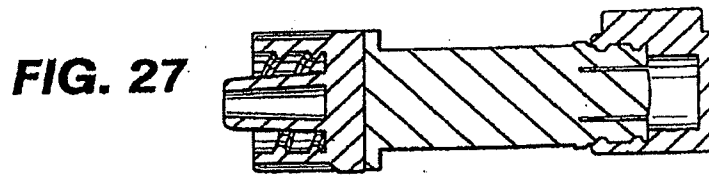
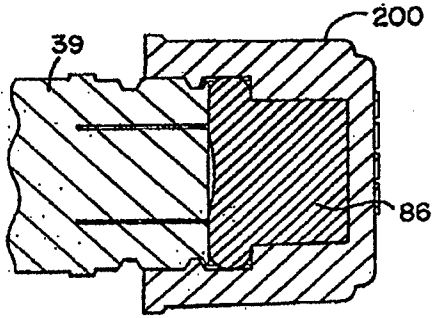


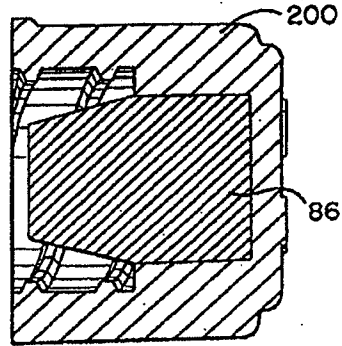
FIG. 26



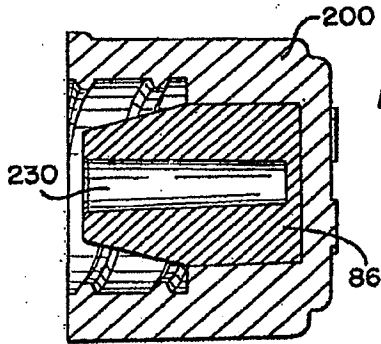
**FIG. 32**



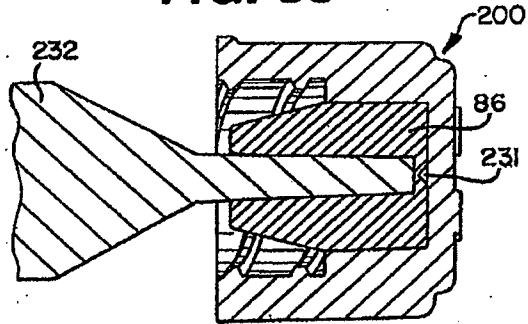
**FIG. 33**



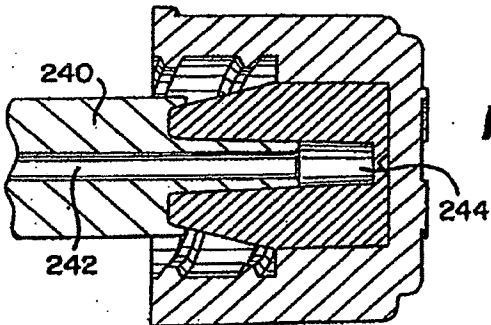
**FIG. 34**



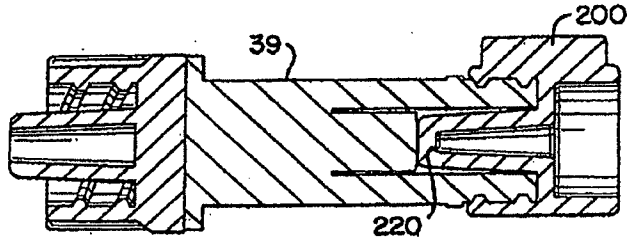
**FIG. 35**



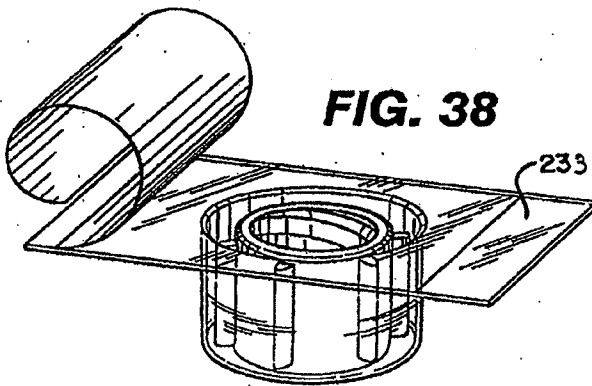
**FIG. 36**



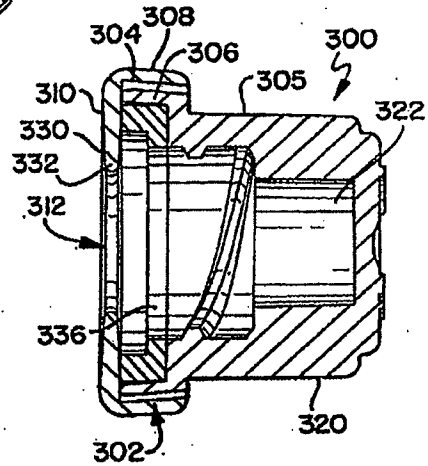
**FIG. 37**



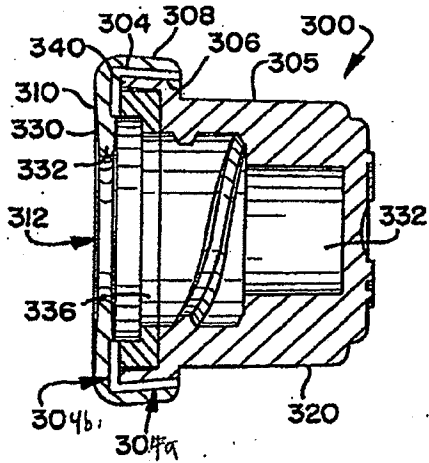
**FIG. 38**



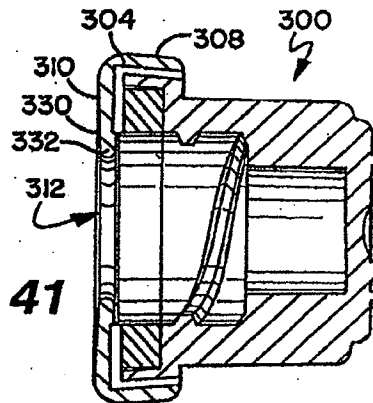
**FIG. 39**



**FIG. 40**

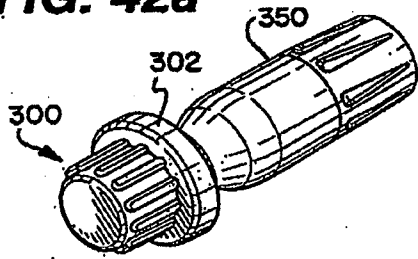


**FIG. 41**

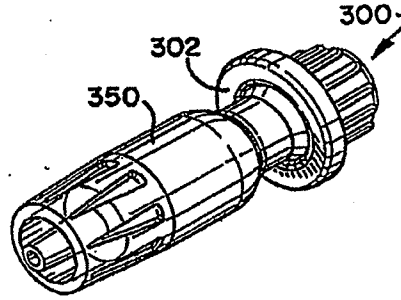




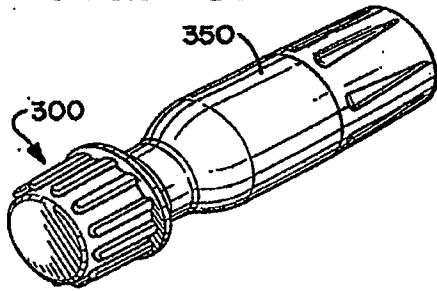
**FIG. 42a**



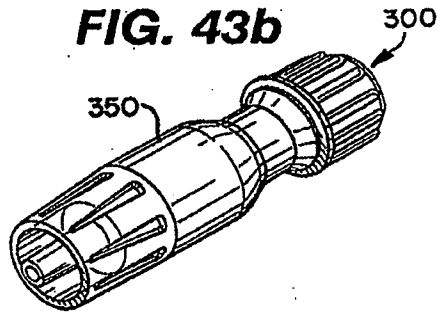
**FIG. 42b**



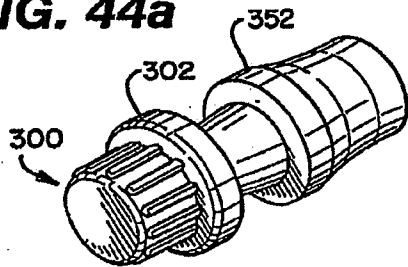
**FIG. 43a**



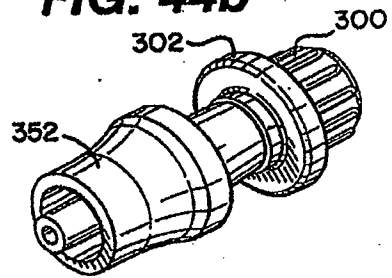
**FIG. 43b**



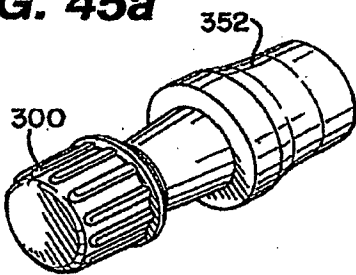
**FIG. 44a**



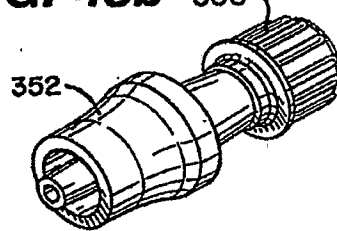
**FIG. 44b**

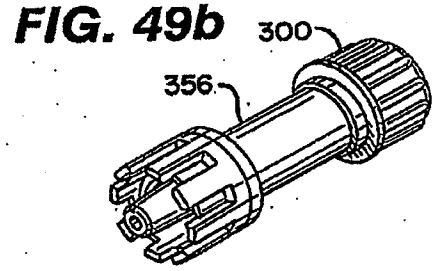
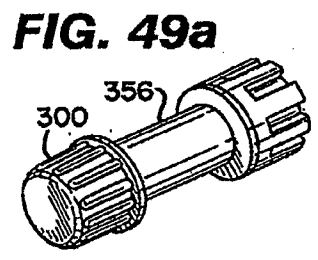
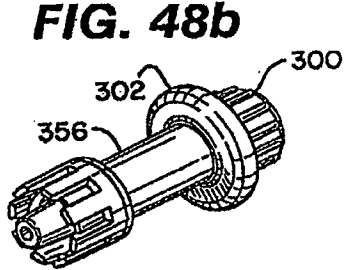
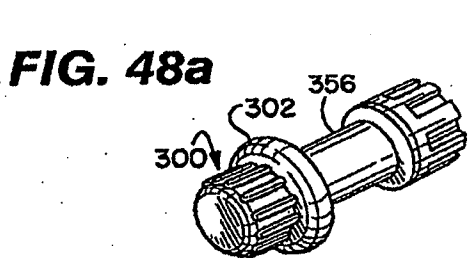
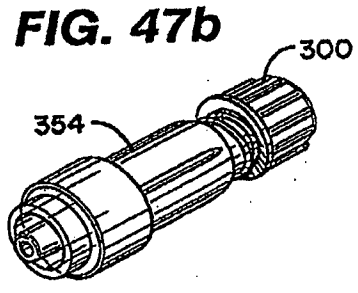
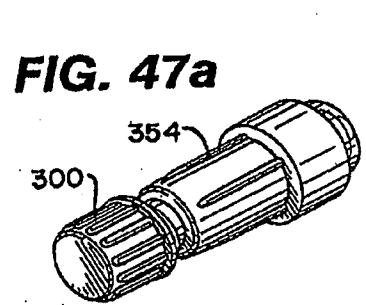
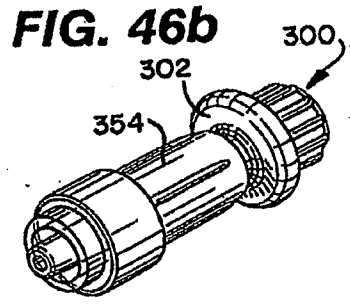
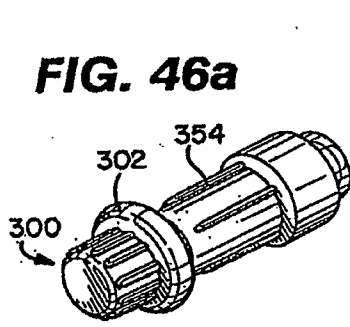


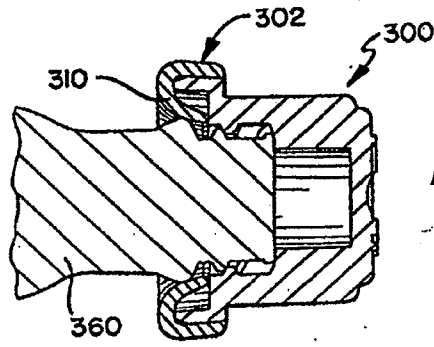
**FIG. 45a**



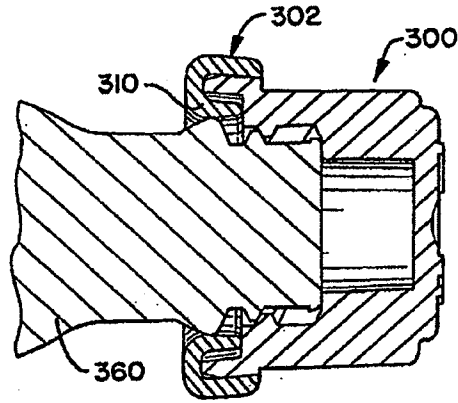
**FIG. 45b**



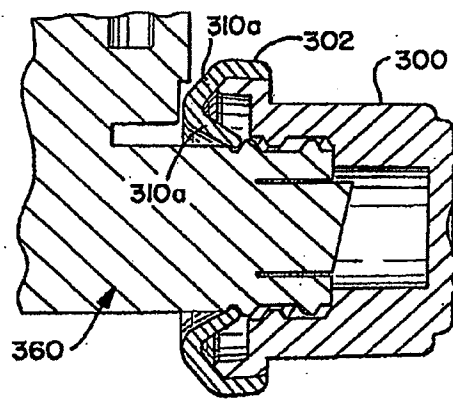




**FIG. 50**

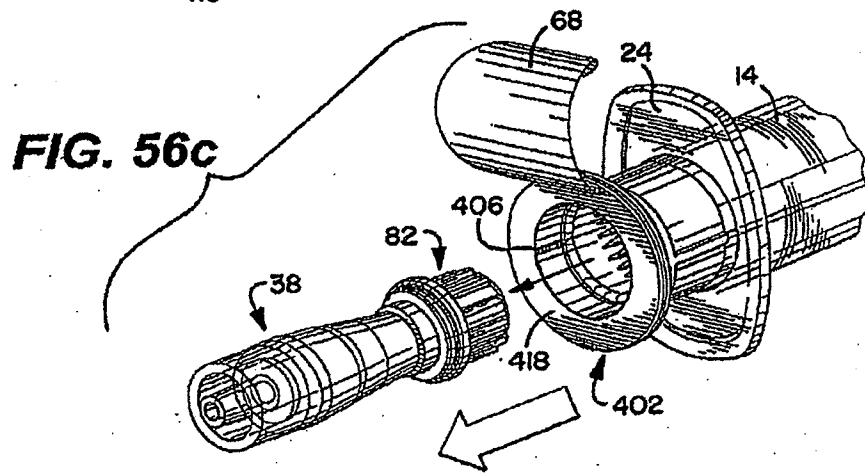
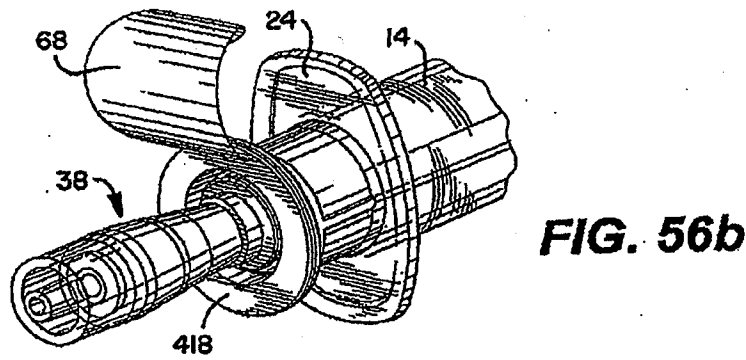
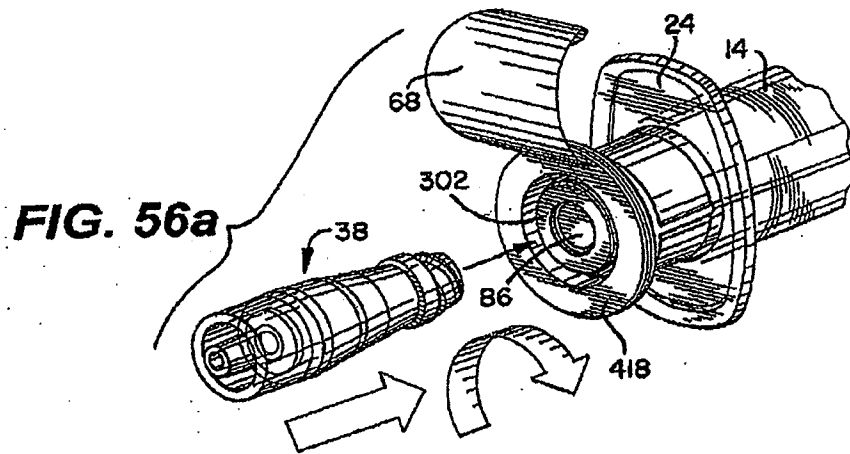


**FIG. 51**

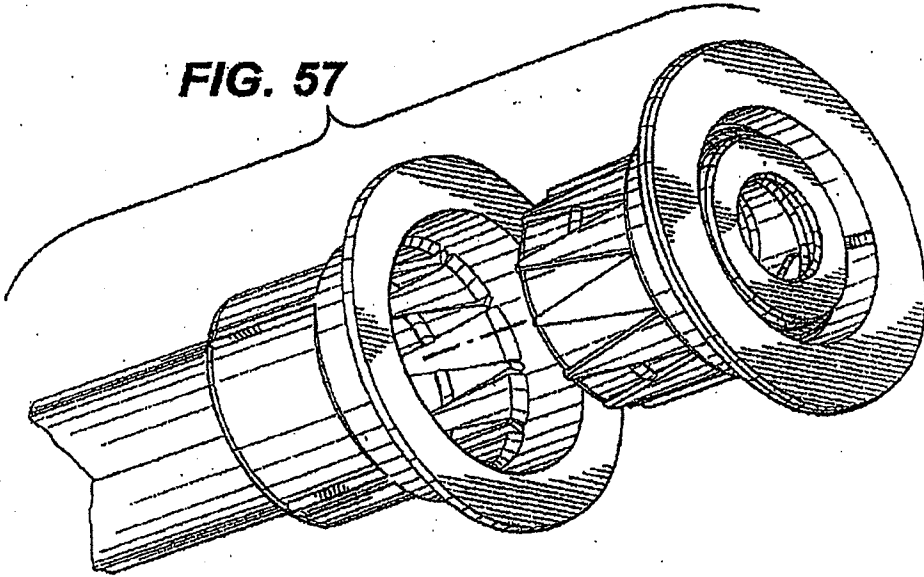


**FIG. 52**

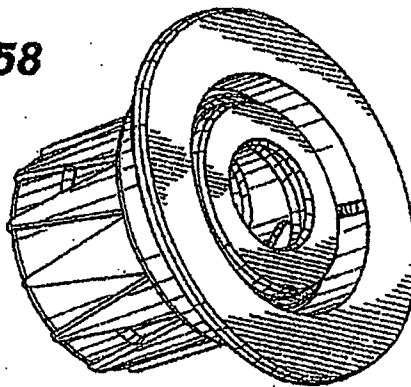




**FIG. 57**



**FIG. 58**





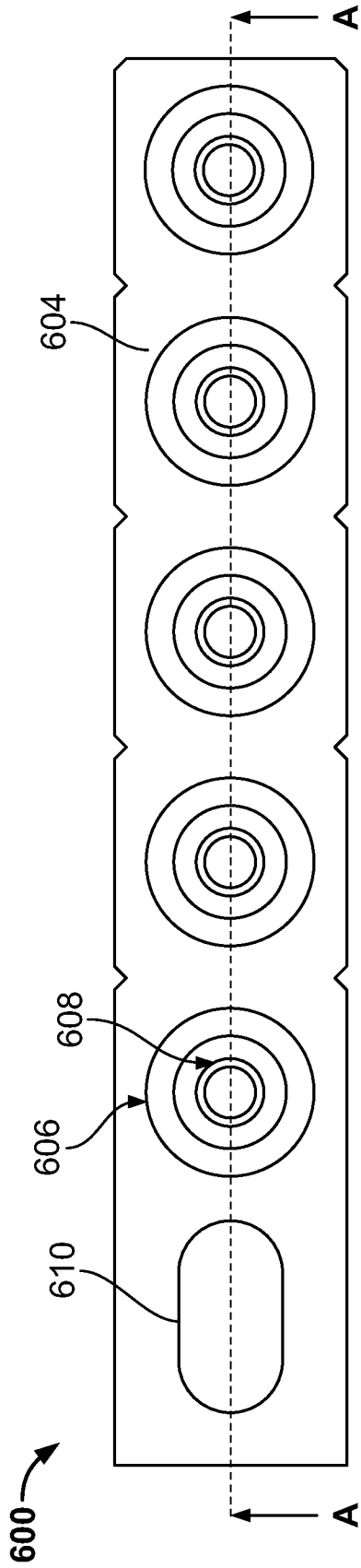


FIG. 62

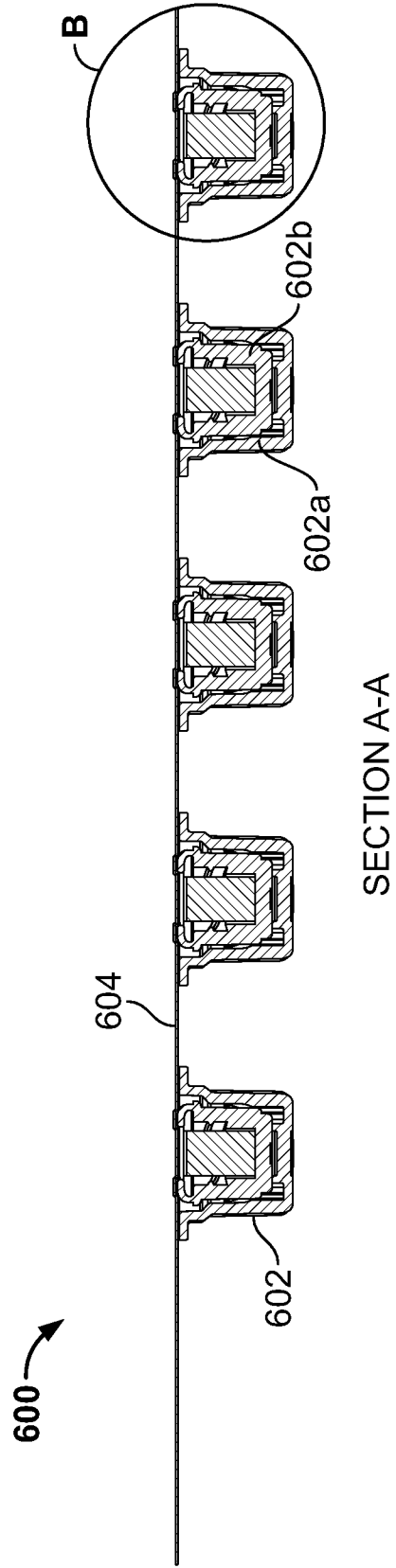


FIG. 63



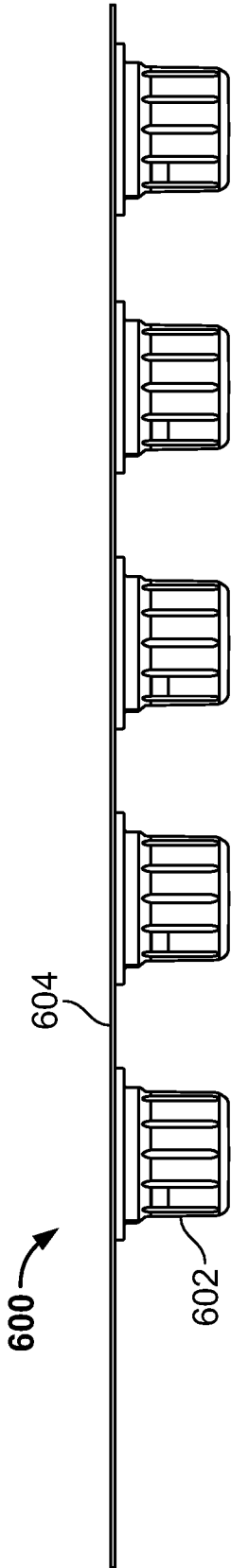
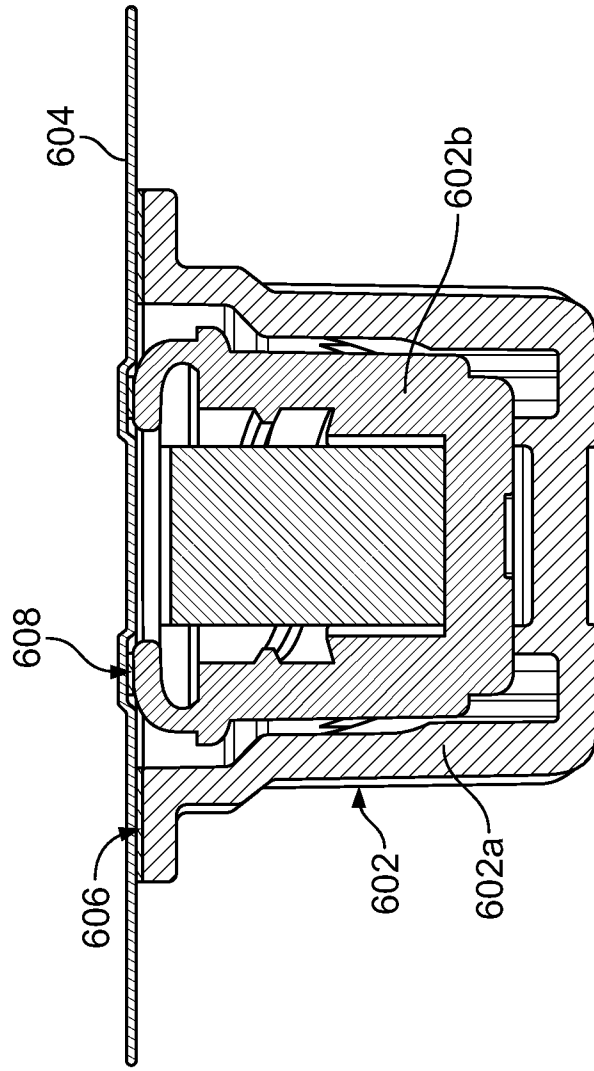


FIG. 64

600



DETAIL B  
SCALE 2:1

FIG. 65

**INTERNATIONAL SEARCH REPORT**

International application No.

PCT/US 15/29019

**A. CLASSIFICATION OF SUBJECT MATTER**

IPC(8) - A61L 2/16 (2015.01)

CPC - A61L 2202/24

According to International Patent Classification (IPC) or to both national classification and IPC

**B. FIELDS SEARCHED**

Minimum documentation searched (classification system followed by classification symbols)  
CPC: A61L 2202/24; IPC(8): A61L 2/16 (2015.01); USPC: 206/210

Documentation searched other than minimum documentation to the extent that such documents are included in the fields searched  
CPC: A61L 2/16, A61L 2/26, A61L 19/34; IPC(8): A61L 2/18 (2015.01); USPC: 15/104.93, 206/467 (keyword limited; terms below)

Electronic data base consulted during the international search (name of data base and, where practicable, search terms used)  
PatBase; Google (Web, Patents, Scholar) Search Terms Used: Medical luer Antiseptic cap plug disinfecting sterilizing Packaging sealing Strip substrate lid cover Adhesive Hole aperture Chamber cavity Outer inner

**C. DOCUMENTS CONSIDERED TO BE RELEVANT**

Category*	Citation of document, with indication, where appropriate, of the relevant passages	Relevant to claim No.
X -- Y	US 2012/0216359 A1 (Rogers et al.), 30 August 2012 (30.08.2012), entire document, especially Fig. 3-4 and 11-13; para [0025], [0030], [0032], [0035], [0045]-[0048] and [0057]	1-3, 5-8 and 10-14 ----- 4, 9 and 15
Y	US 4,444,310 A (Odell), 24 April 1984 (24.04.1984), entire document, especially Fig. 2; col 4, ln 28-35	4, 9 and 15
A	US 3,301,392 A (Eddingfield), 31 January 1967 (31.01.1967), entire document	1-15
A	US 2012/0302970 A1 (Tennican), 29 November 2012 (29.11.2012), entire document, especially Fig. 20-22	1-15
A	US 2014/0034540 A1 (Solomon et al.), 06 February 2014 (06.02.2014), entire document	1-15
A	US 2013/0053751 A1 (Holtham), 28 February 2013 (28.02.2013), entire document	1-15

Further documents are listed in the continuation of Box C.

* Special categories of cited documents:	"T" later document published after the international filing date or priority date and not in conflict with the application but cited to understand the principle or theory underlying the invention
"A" document defining the general state of the art which is not considered to be of particular relevance	"X" document of particular relevance; the claimed invention cannot be considered novel or cannot be considered to involve an inventive step when the document is taken alone
"E" earlier application or patent but published on or after the international filing date	"Y" document of particular relevance; the claimed invention cannot be considered to involve an inventive step when the document is combined with one or more other such documents, such combination being obvious to a person skilled in the art
"L" document which may throw doubts on priority claim(s) or which is cited to establish the publication date of another citation or other special reason (as specified)	"&" document member of the same patent family
"O" document referring to an oral disclosure, use, exhibition or other means	
"P" document published prior to the international filing date but later than the priority date claimed	

Date of the actual completion of the international search  
09 July 2015 (09.07.2015)

Date of mailing of the international search report  
**28 JUL 2015**

Name and mailing address of the ISA/US  
Mail Stop PCT, Attn: ISA/US, Commissioner for Patents  
P.O. Box 1450, Alexandria, Virginia 22313-1450  
Facsimile No. 571-273-8300

Authorized officer:  
**Lee W. Young**  
PCT Helpdesk: 571-272-4300  
PCT OSP: 571-272-7774