

(19) (KR)  
(12) (Y1)

(51) 。 Int. Cl. 7  
B66B 7/06

(45) 2002 05 24  
(11) 20 - 0276511  
(24) 2002 05 13

(21) 20 - 2002 - 0005423  
(22) 2002 02 23

(73) 597 - 2

(72) 7 - 5 201

(74)

:

가 :

(54)

60' ) , (150a)(150b)가 (110) 가 (160)(160') (160)(1 (110)

(130) , (150a)(150b), (140) (180)(180') , (170a)(170b)가 가 (120)

(190)가 , 가 (170a)(170b) 가

가

2

, , , ,

1

2

3 2

4 2

5

\* \*

100 : 110 :

120 : 130 :

140 : 150a : 1

150b : 2 160,160' :

170a : 1 170b : 2

180,180' : 190 :

1:1

가

가

가  
가

1996 - 000750

US5,566,785

.

,  
가

,

1 (1) , (1) 가 (10) , 가  
 (2) (3) , (3) (2) , (1) (2)  
 (2) (4) . 가 (1)

, (1) 1 2 (5a,5b)가 ,  
 (2) (2) 가 (6)가 (4) ,  
 1 (5a) (3) , 1 2 (5a,5b)  
 (6)

, (10) , 2:1 , 가

1:1 ,

, 가 가  
 , 가  
 가 , 가

, 1 , 1

2 , 2

, 1 가 ,

, 가 ,

, , 1,2

, 1,2 ,

2 , 4 2 , 5 , 3 2

가 (110) (120) ; (120) (100) , 가 (110) (130) ;

(120) (120) (140) ; (110) ( )

(160)(160') ; (150a)(150b)가 가 (160)(160')

(110) (180)(180') ; (170a)(170b)가 가

(150a)(150b), (140) (170a)(170b) (120) (13

0)

(160)(160') "ㄷ" (1 (200) , 1 (200) (1

60)(160') "ㄱ" (110) (210) (200)

(160)(160')

(160)(160')

(160)(160') 1 (200) (100)

(230)(230') (160)(160') 1 (200) (230)(230')가 (220)

(160)(160') (180)(180')

(180') (240) (100) (160)(160') (180)

(250)(250')가 , (250)(250') (240)

(230)(230')(250)(250')

(151) (160)(160') 1 (150a) 가 " "  
 가 " " 1 (152) (150a) 2 (150b)  
 (160)

80)(180') (180)(180') "ㄷ" (1) (1)  
 (260)(260') "ㄱ" (260)(260') (110) 2  
 (270) (180)(180')  
 (280)

(171) (180)(180') 1 (170a) 가 " "  
 가 " " 1 (170a) 2 (170b)  
 (172) (180)

b) (120) (190) (190) 1,2 (150a)(150  
 (190) 1,2 (170a)(170b) (140) (130)

1 (160)(160') (180)(180') (110)  
 (200) 2 (260)(260')  
 (160)(160') (180)(180') (110)

(110) 가 (120) (130)

(100)

(120) (140)가 (140)가  
 (150b) (140)가 (190) 1 (150a) 2  
 (190) (150a) 2 (150b)  
 (120) (150a)(150b)가 (120)  
 (120) 1,2 (170a)(170b) (130)

가 1:1 가  
 가  
 가

(57)

1.

(110) (150a)(15  
 0b)가 가 (160)(160') (160)(160') (110)  
 (170a)(170b)가 가 (120) (150a)(1  
 50b), (180)(180') (170a)(170b) (130)  
 (190)가

2.

1 (160)(160') 1 (200) (110) 1 (200)  
 (160)(160') (160)(160') (220) (210)  
 (240) (180)(180')  
 (110) 2 (260)(260') (180)(180') 2 (260)(260')  
 (280) (270) (180)(180')

3.

2 (160)(160') 1 (200) (100)  
 (230)(230') (260) (230)(230')가

4.

2 , (160)(160') (180)(180') ( (250)(250')가  
 100) , (250)(250') (240)

5.

3 4 , (230)(230')(250)(250')

6.

1 , (190) (120) , (120) (180)  
 (180) 1,2 (150a)(150b) , (190) 1,2  
 (140) , (190) (130)  
 (170a)(170b)

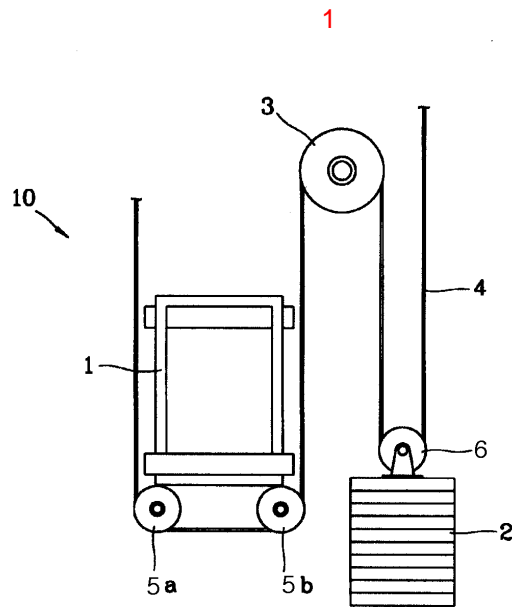

2

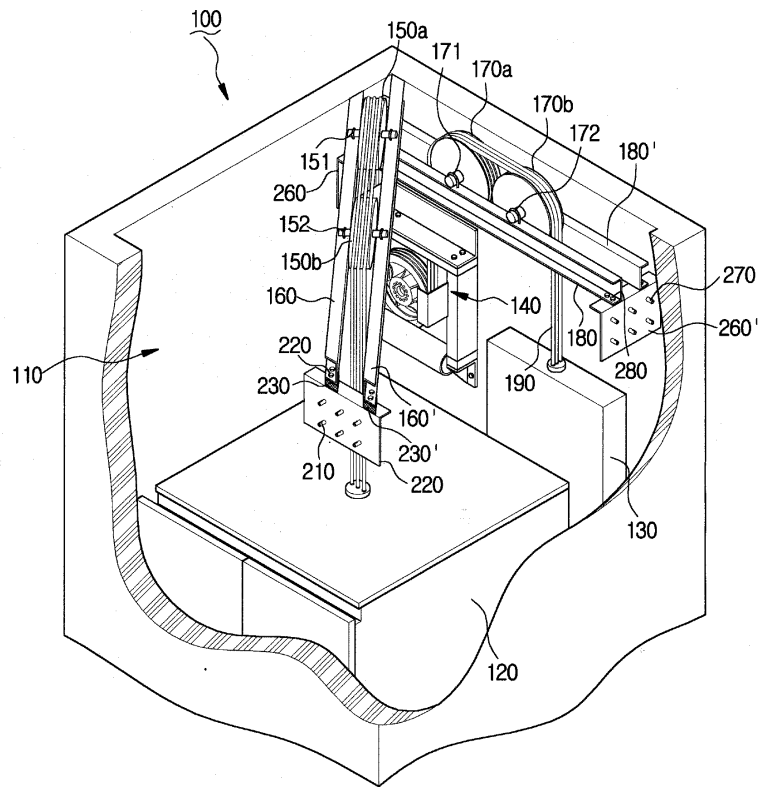



3

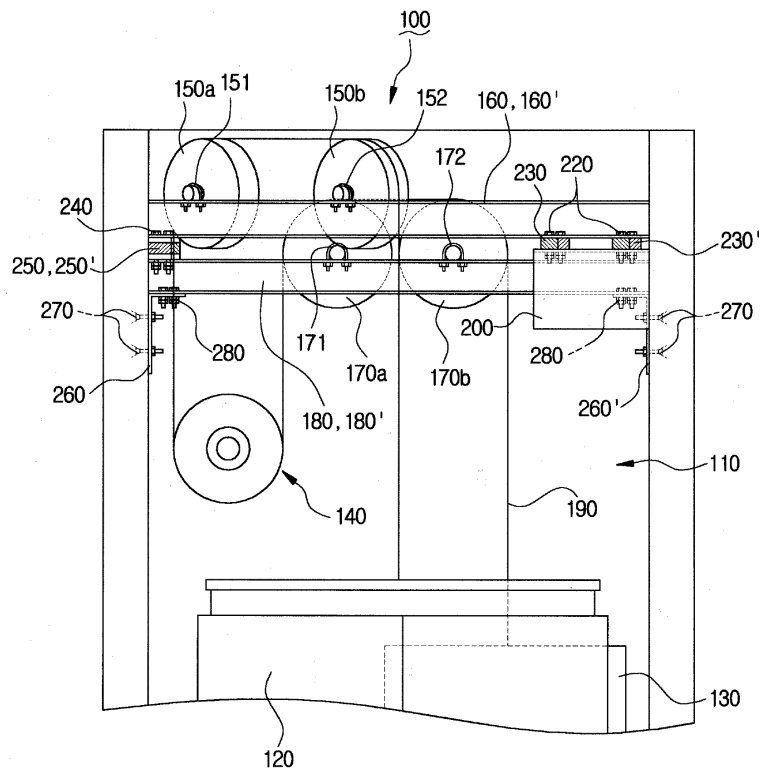

4

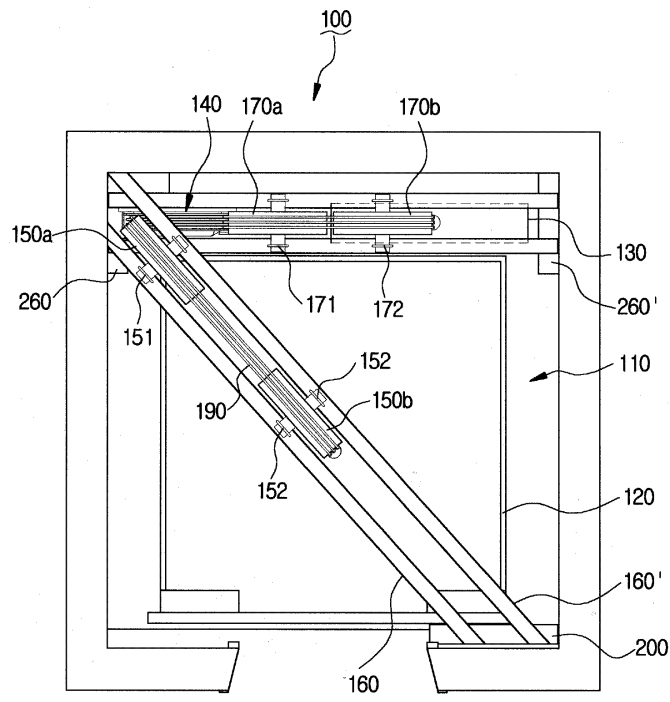

5

