

No. 855,453.

PATENTED JUNE 4, 1907.

C. H. FOSTER.  
BOILER SUPPORT.  
APPLICATION FILED NOV. 8, 1906.

2 SHEETS—SHEET 1.

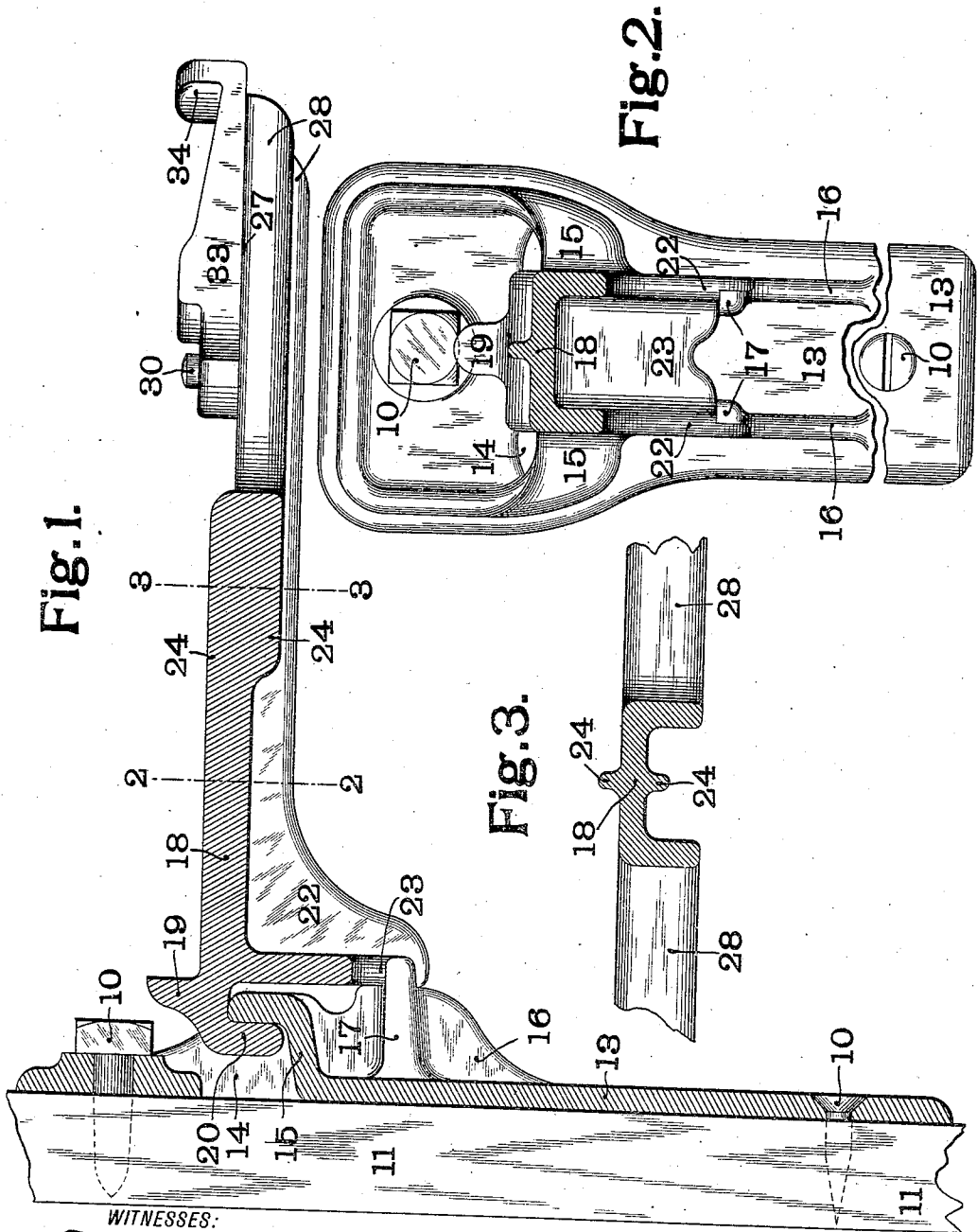

WITNESSES:  
*Fred Hauke*  
*Walter Shelton*

INVENTOR  
Chas. H. Foster.  
BY  
*Lowell P. Brown*  
ATTORNEYS.

No. 855,453.

PATENTED JUNE 4, 1907.

C. H. FOSTER.  
BOILER SUPPORT.  
APPLICATION FILED NOV. 8, 1905.

2 SHEETS—SHEET 2.

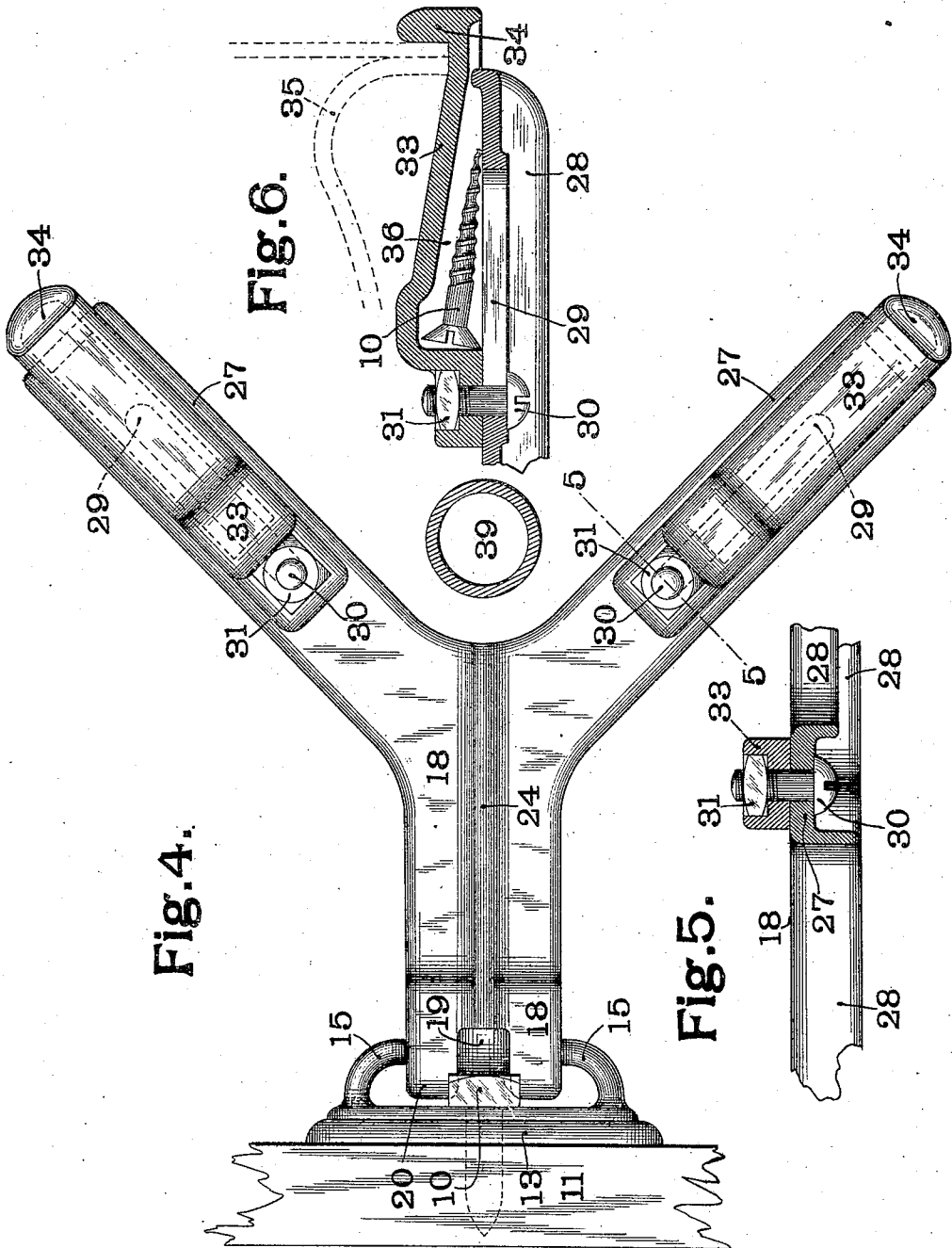

WITNESSES:  
*Fred Kemke*  
*Walter Shelton*

INVENTOR  
 Chas. H. Foster.  
 BY  
*London & Engstrom*  
 ATTORNEYS.

# UNITED STATES PATENT OFFICE.

CHARLES H. FOSTER, OF ST. LOUIS, MISSOURI.

## BOILER-SUPPORT.

No. 855,453.

Specification of Letters Patent.

Patented June 4, 1907.

Application filed November 8, 1905. Serial No. 286,342.

*To all whom it may concern:*

Be it known that I, CHARLES H. FOSTER, a citizen of the United States, residing at the city of St. Louis, in the State of Missouri, have invented a certain new and useful Boiler-Support, of which the following is such a full, clear, and exact description as will enable any one skilled in the art to which it appertains to make and use the same, reference being had to the accompanying drawings, forming part of this specification.

My invention relates more particularly to a boiler stand intended primarily to be supported from the wall, and has for its object to provide such a boiler stand which will be simple and inexpensive in construction, and will be provided with suitable means for storing the fastening devices used in securing the boiler support to the wall. It has been found that in setting up this class of boiler supports or stands inadequate fastening devices are sometimes used in fastening the support to the wall. As a result, the stand, after the boiler is placed thereupon, frequently pulls away from its fastening. It is desirable, therefore, to ship with each stand a fastening device adequate to the strain to be placed upon it. It frequently happens, however, that these fastening devices are mislaid or lost, and by my invention I provide a simple and secure means for shipping the fastening devices with the stand in such position that they cannot readily become detached from the same.

In the drawings, in which like characters of reference indicate similar parts in the different views, Figure 1 is a vertical section of my boiler support; Fig. 2 is a section on the line 2—2 of Fig. 1; Fig. 3 is a detail section on the line 3—3 of Fig. 1; Fig. 4 is a top plan view of the stand; Fig. 5 is a detail section on the line 5—5 of Fig. 4, and Fig. 6 is an enlarged vertical sectional view of the adjustable bearing showing the means for securing the fastening devices to the stand.

10 indicates the screws for fastening the device to the wall 11. The upper screw 10 passes through a suitable perforation in the upper part of the wall piece 13. This is provided at 14 with an opening. Across the lower edge of this opening is an outwardly and upwardly extending flange 15. The flange 15 is provided with downwardly extending ribs 16 having lugs 17, as best shown in Figs. 1 and 2. The horizontally extend-

ing arm 18 is provided with a lug 19 and a downwardly extending flange 20 adapted to fit over the flange 15. It is also provided with downwardly extending strengthening ribs 22 connected by a web 23 adapted to fit over the lugs 17 above described, as best shown in Figs. 1 and 2. The horizontally extending arm 18 is also provided with strengthening ribs 24. The outer end of the arm 18 carries two laterally extending arms 27, disposed at substantially right angles to one another. These arms 27 are provided with downwardly extending strengthening ribs 28 and with longitudinal slots 29. Through the slots 29 pass screw bolts 30 provided with nuts 31. These bolts also pass through perforations in one end of bearings 33. The opposite end of each of the bearings 33 is provided with a lug 34 against which the boiler is adapted to rest, as indicated by dotted lines at 35 in Fig. 6. The under side of the bearing 33 is recessed, as shown at 36, to receive the screw 10 of a proper size for use in fastening the wall piece 13 in position.

39 is the boiler waste pipe, which passes upward to the boiler between the arms 27.

My boiler stand is customarily shipped with the portion constituting the arms 18 and 27 detached from the wall piece 13. The fastening devices, or screws 10, are placed in the recesses 36 and the bolts 30 tightened, thereby fastening the screws 10 securely to the arms 27. When the device is unpacked for use, the screws 10 are removed by loosening the bolts 30 and the wall piece 13 secured by them in position. The horizontal arms 18 and 27 are then detachably secured to the wall piece 13 by means of the lugs 20 and 23. It will be seen also that the bearings 33 are longitudinally adjustable on the arms 27, thus enabling the stand to be adjusted to boilers of various diameters, the lugs 19 and 34 being in contact with the sides of the boiler.

Having fully described my invention, what I claim as new and desire to secure by Letters Patent of the United States, is—

1. In a boiler support, the combination with a wall bracket, of an arm carried thereby and provided with a bearing for the boiler, arms extending laterally from said first named arm, and removable bearing pieces for the boiler carried by said second named arms, the spaces between said arms

and bearing pieces forming recesses constituting receptacles for the fastening means for the bracket.

2. In a boiler support, the combination  
5 with a wall bracket, of an arm carried there-  
by and provided with a bearing for the  
boiler, arms extending laterally from said  
first named arm, and adjustable bearing  
pieces for the boiler carried by said second  
10 named arms, the spaces between said arms  
and bearing pieces forming recesses consti-  
tuting receptacles for the fastening means  
for the bracket.

3. In a boiler stand, the combination with  
15 a wall bracket, of a slotted arm carried by

said bracket, a bearing piece for the boiler,  
means at one end of said bearing piece for  
movably and detachably securing it to said  
slotted arm, and an upwardly extending lug  
at the other end of said bearing piece, the  
20 under face of said bearing piece being pro-  
vided with a recess for receiving the fasten-  
ing means for said wall bracket.

In testimony whereof, I have hereunto set  
my hand and affixed my seal in the presence  
25 of the two subscribing witnesses.

CHARLES H. FOSTER. [L. s.]

Witnesses:

HAROLD R. SMALL,  
W. A. ALEXANDER.