

(12) **United States Design Patent**  
**Hasbrook et al.**

(10) **Patent No.:** **US D675,625 S**  
(45) **Date of Patent:** **\*\* Feb. 5, 2013**

(54) **TABLET COMPUTER KEYBOARD-CASE**

(75) Inventors: **William Benjamin Hasbrook**, Tualatin, OR (US); **William Westwood**, Escondido, CA (US); **Sean Michael Stuck**, Portland, OR (US)

(73) Assignee: **mophie, Inc.**, Santa Ana, CA (US)

(\*\*) Term: **14 Years**

(21) Appl. No.: **29/400,009**

(22) Filed: **Aug. 22, 2011**

(51) **LOC (9) Cl.** ..... **14-02**

(52) **U.S. Cl.** ..... **D14/440**

(58) **Field of Classification Search** ..... D14/250, D14/251, 253, 240, 217, 496, 440, 203.3, D14/203.4, 203.5, 203.8, 432, 439, 300; D3/218, 215, 201; 220/4.02; 248/309.1; 361/679.56, 679.03; 379/426, 433.11, 455; 455/575.1, 575.8; 190/100; 206/305, 320

See application file for complete search history.

(56) **References Cited**

U.S. PATENT DOCUMENTS

4,259,568 A \* 3/1981 Dynesen ..... 235/1 D  
(Continued)

*Primary Examiner* — Cynthia Underwood

(57) **CLAIM**

The ornamental design for a tablet computer keyboard-case, as shown and described in the Figures.

**DESCRIPTION**

FIG. 1 is a three-quarter view of a tablet computer being inserted into the tablet computer keyboard-case, the tablet computer keyboard-case being opened to 180 degrees; FIG. 2 is a three-quarter view of the tablet computer being inserted into the tablet computer keyboard-case, the tablet computer keyboard-case being opened to 90 degrees; FIG. 3 is a three-quarter view of the tablet computer within the tablet computer keyboard-case, the tablet computer keyboard-case being open;

FIG. 4 is a three-quarter view of the tablet computer within the tablet computer keyboard-case, the tablet computer keyboard-case being opened to 90 degrees;

FIG. 5 is a three-quarter view of the tablet computer within the tablet computer keyboard-case, where the tablet computer is rotated less than 90 degrees;

FIG. 6 is a three-quarter view of the tablet computer within the tablet computer keyboard-case, where the tablet computer is rotated 90 degrees;

FIG. 7 is a three-quarter view of the tablet computer within the tablet computer keyboard-case, where the tablet computer is rotated more than 90 degrees;

FIG. 8 is a three-quarter view of the tablet computer within the tablet computer keyboard-case, where the tablet computer is rotated 180 degrees;

FIG. 9 is a bottom three-quarter view of the tablet computer within the tablet computer keyboard-case, the tablet computer keyboard-case being open, and a case stand being closed;

FIG. 10 is a bottom three-quarter view of the tablet computer within the tablet computer keyboard-case, the tablet computer keyboard-case being open, and a case stand being partially-open;

FIG. 11 is a bottom three-quarter view of the tablet computer within the tablet computer keyboard-case, the tablet computer keyboard-case being open, and a case stand being open;

FIG. 12 is a bottom three-quarter view of the tablet computer within the tablet computer keyboard-case, the tablet computer keyboard-case being open, and a case stand being fully-open;

FIG. 13 is a three-quarter view of the tablet computer within the tablet computer keyboard-case, where the tablet computer is rotated 180 degrees, and the tablet computer keyboard-case is partially closed;

FIG. 14 is a three-quarter view of the tablet computer within the tablet computer keyboard-case, where the tablet computer is rotated 180 degrees, and the tablet computer keyboard-case is fully closed; and,

FIG. 15 is a three-quarter view of the tablet computer within the tablet computer keyboard-case, where the tablet computer is rotated zero degrees, and the tablet computer keyboard-case is fully closed.

The broken lines showing the tablet computer are for the purpose of illustrating environmental structure, and forms no part of the claimed design.

**1 Claim, 15 Drawing Sheets**

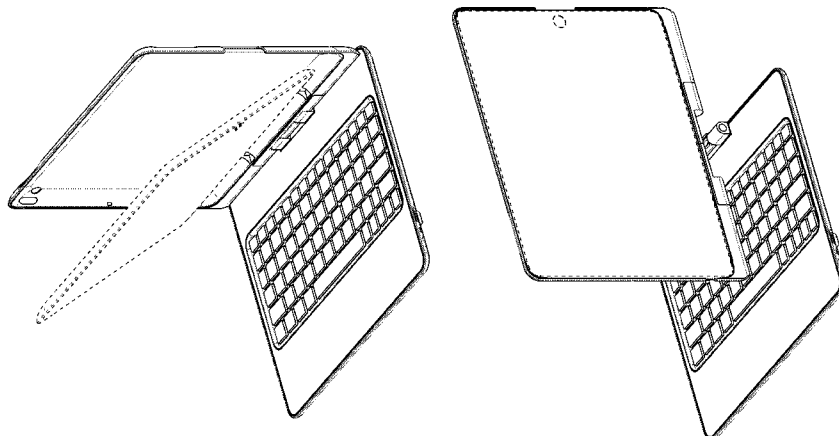

# US D675,625 S

Page 2

## U.S. PATENT DOCUMENTS

5,375,076	A *	12/1994	Goodrich et al. ....	361/679.17	D652,831	S *	1/2012	Lee et al. ....	D14/315
5,383,138	A *	1/1995	Motoyama et al. ....	361/679.27	8,139,357	B2 *	3/2012	Trang ....	361/679.59
5,847,698	A *	12/1998	Reavey et al. ....	345/173	D659,139	S *	5/2012	Gengler ....	D14/392
7,042,712	B2 *	5/2006	Ghosh et al. ....	361/679.03	8,201,687	B2 *	6/2012	Zeliff et al. ....	206/320
7,318,521	B2 *	1/2008	Lau ....	206/45.24	8,230,992	B2 *	7/2012	Law et al. ....	206/320
7,502,225	B2 *	3/2009	Solomon et al. ....	361/679.41	2001/0009500	A1 *	7/2001	Selker ....	361/683
D611,045	S *	3/2010	Andre et al. ....	D14/327	2009/0017883	A1 *	1/2009	Lin ....	455/575.8
D620,001	S *	7/2010	Reed et al. ....	D14/315	2010/0294909	A1 *	11/2010	Hauser et al. ....	248/456
D637,596	S *	5/2011	Akana et al. ....	D14/341	2012/0194448	A1 *	8/2012	Rothkopf ....	345/173

\* cited by examiner

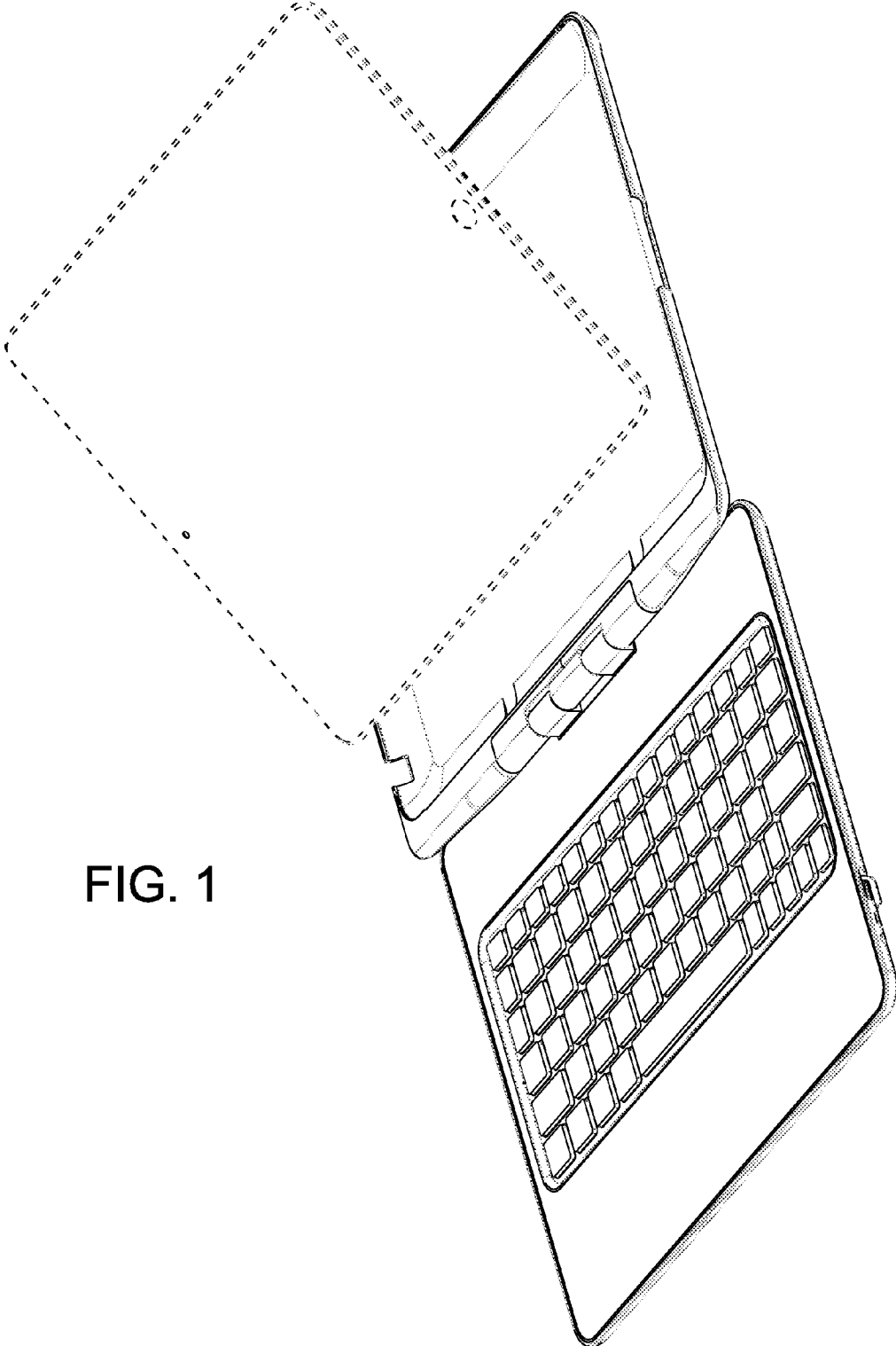

FIG. 1

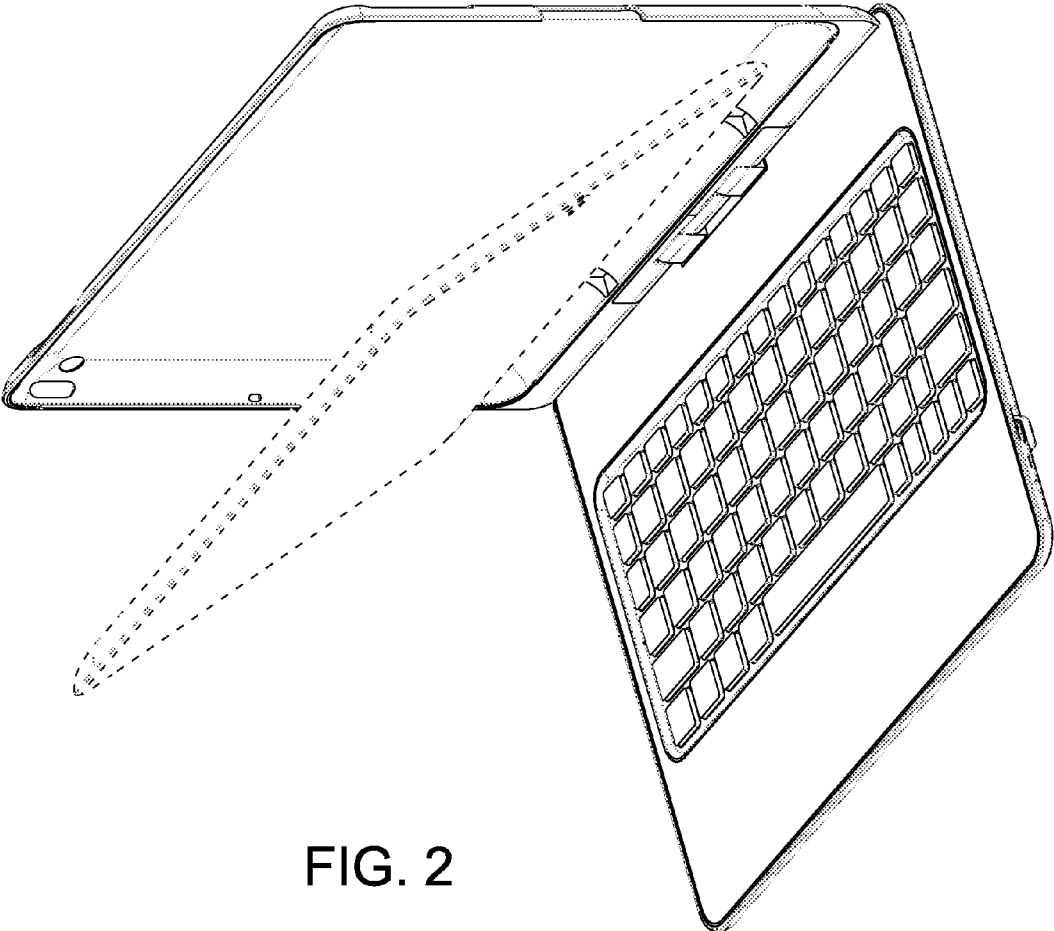

FIG. 2

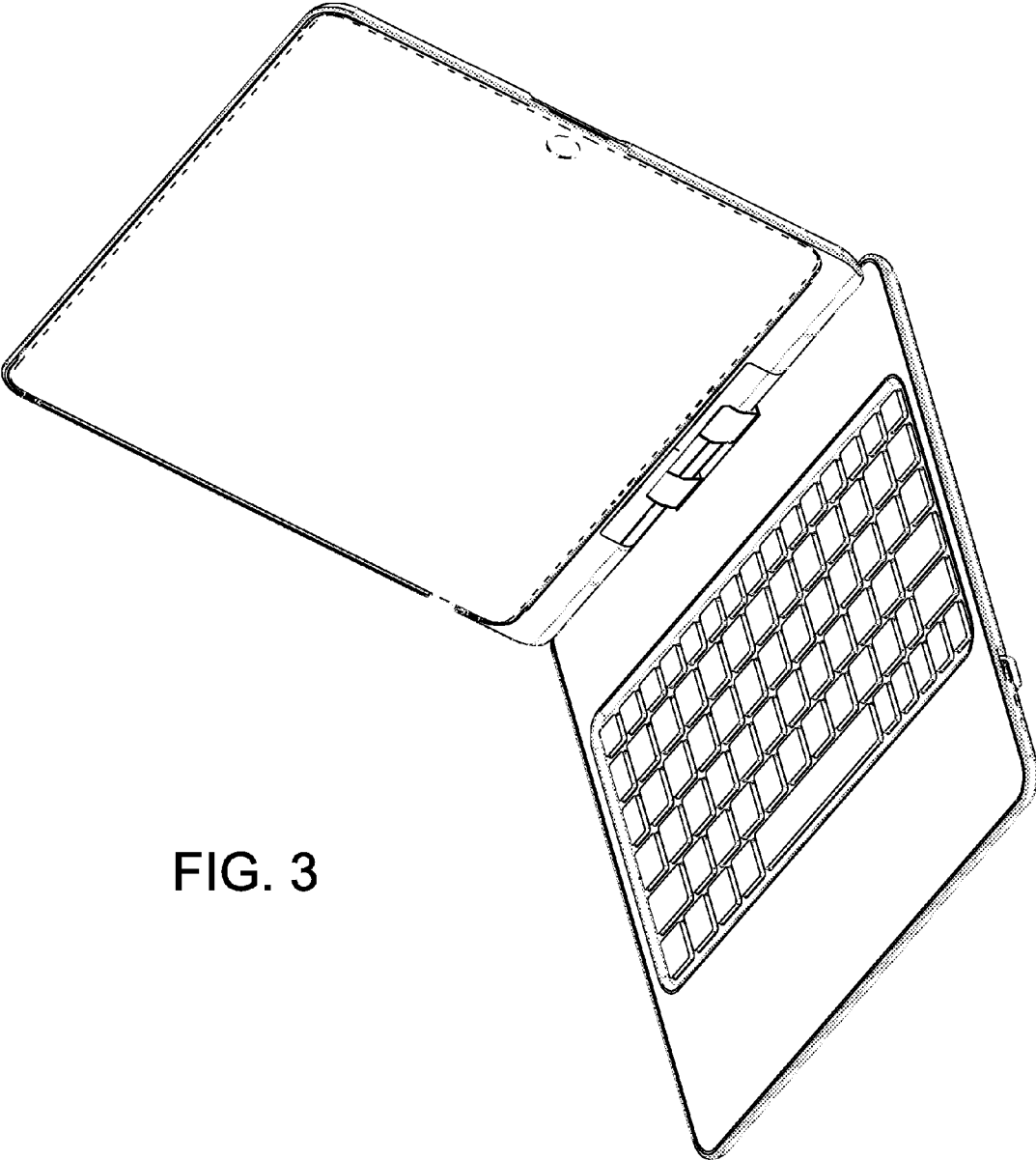

FIG. 3

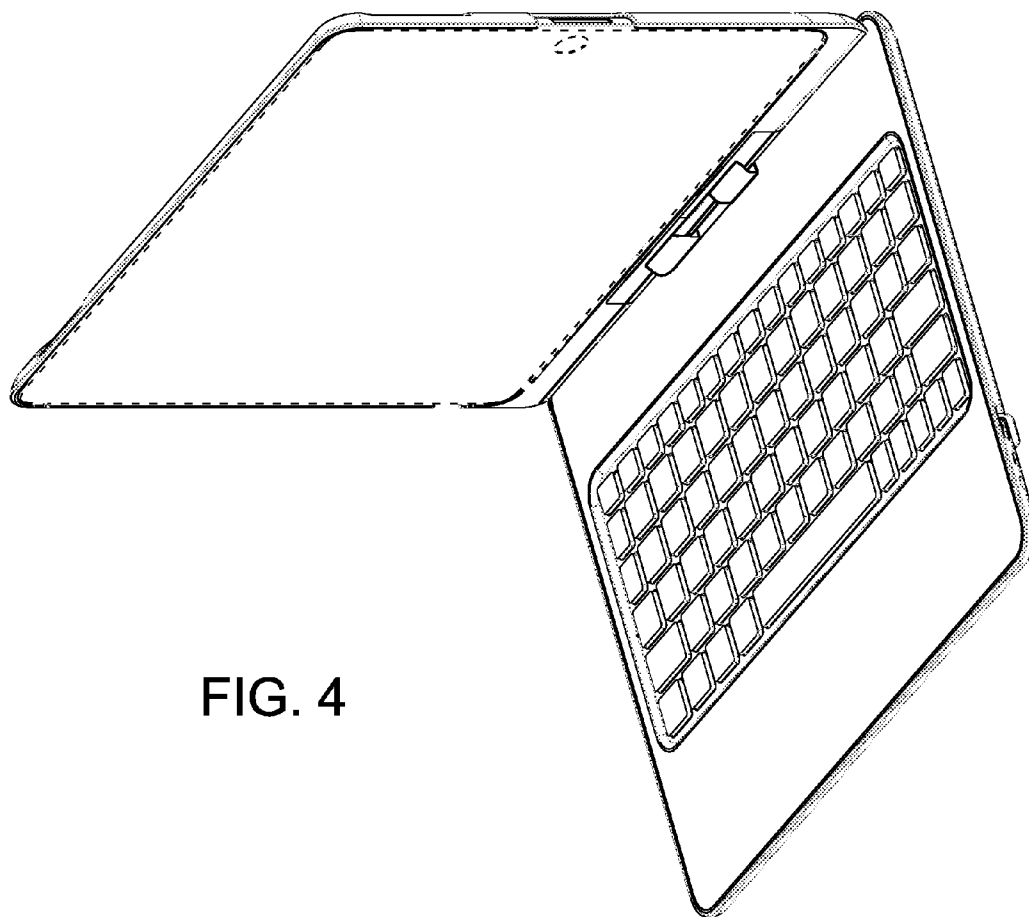

FIG. 4

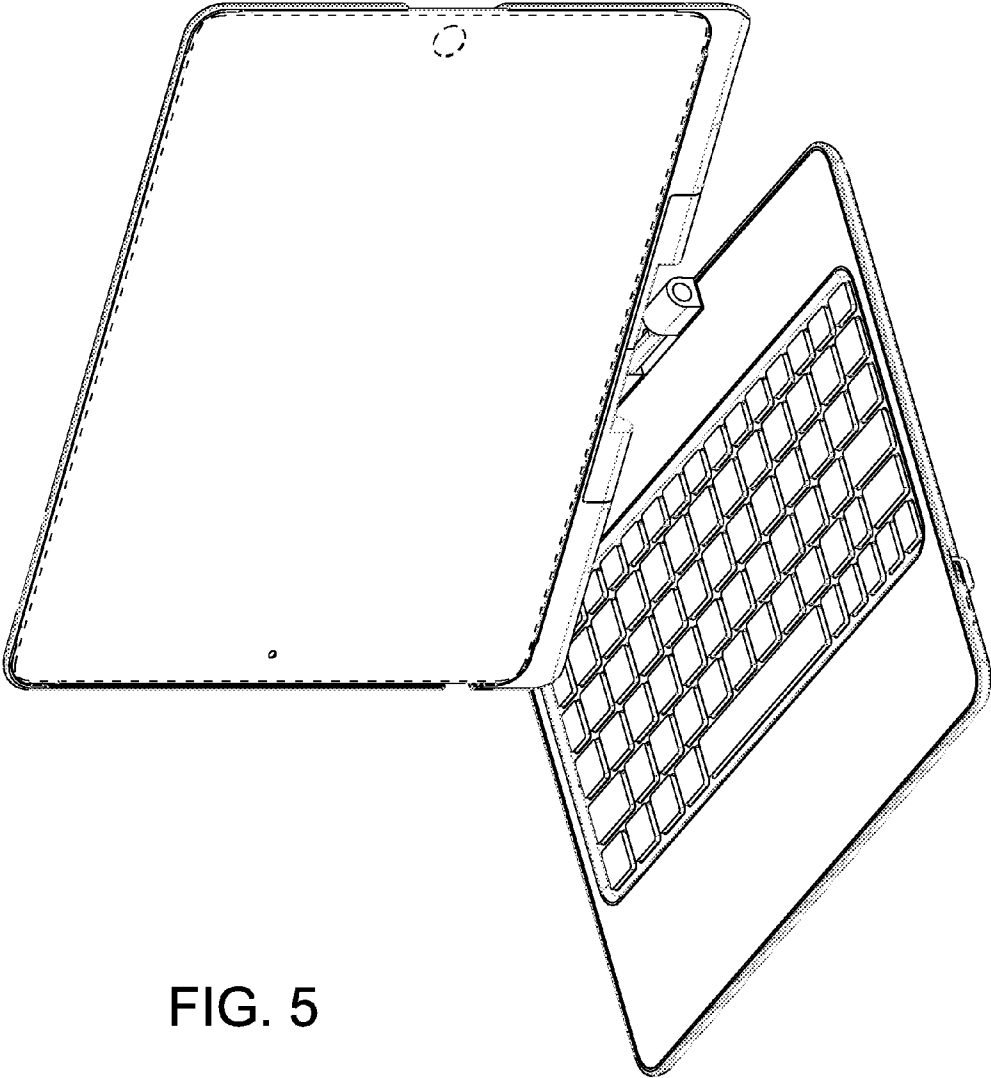

FIG. 5

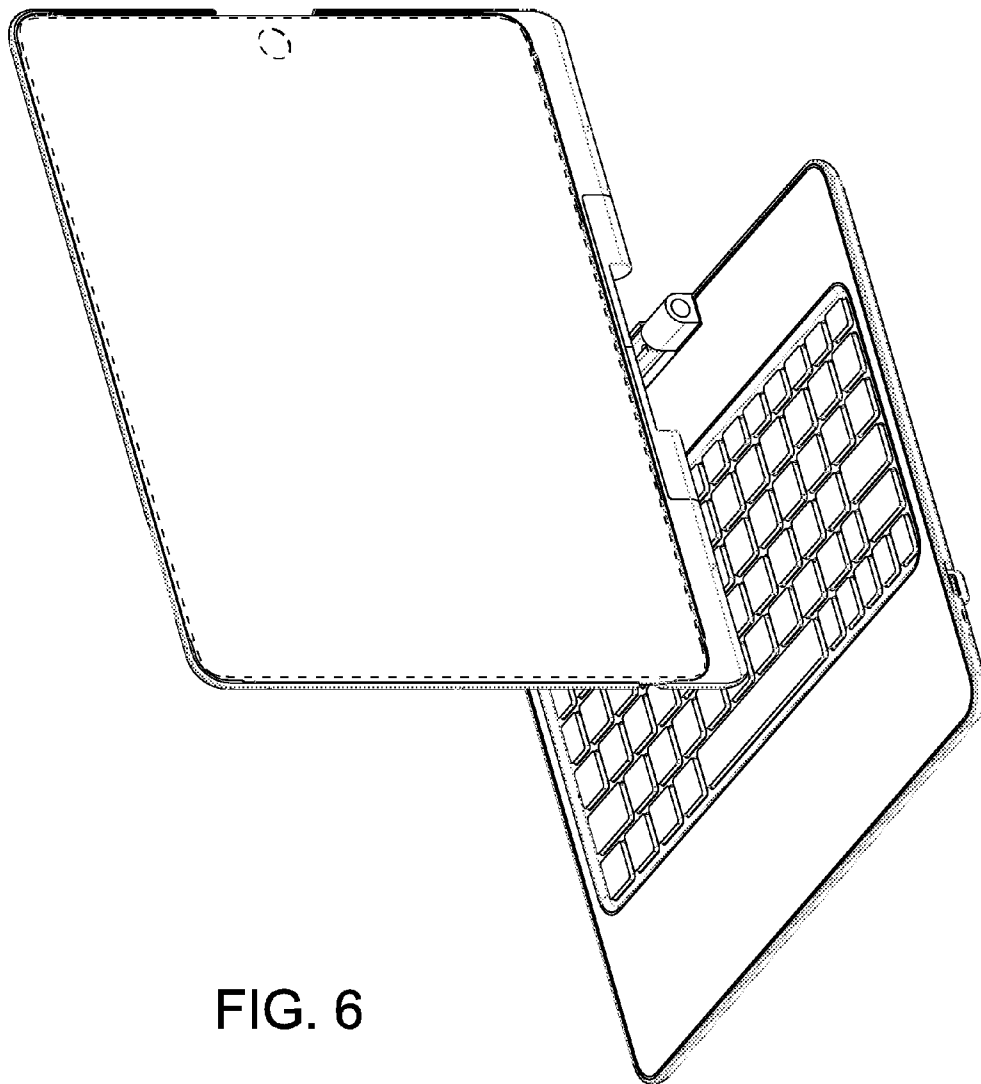

FIG. 6



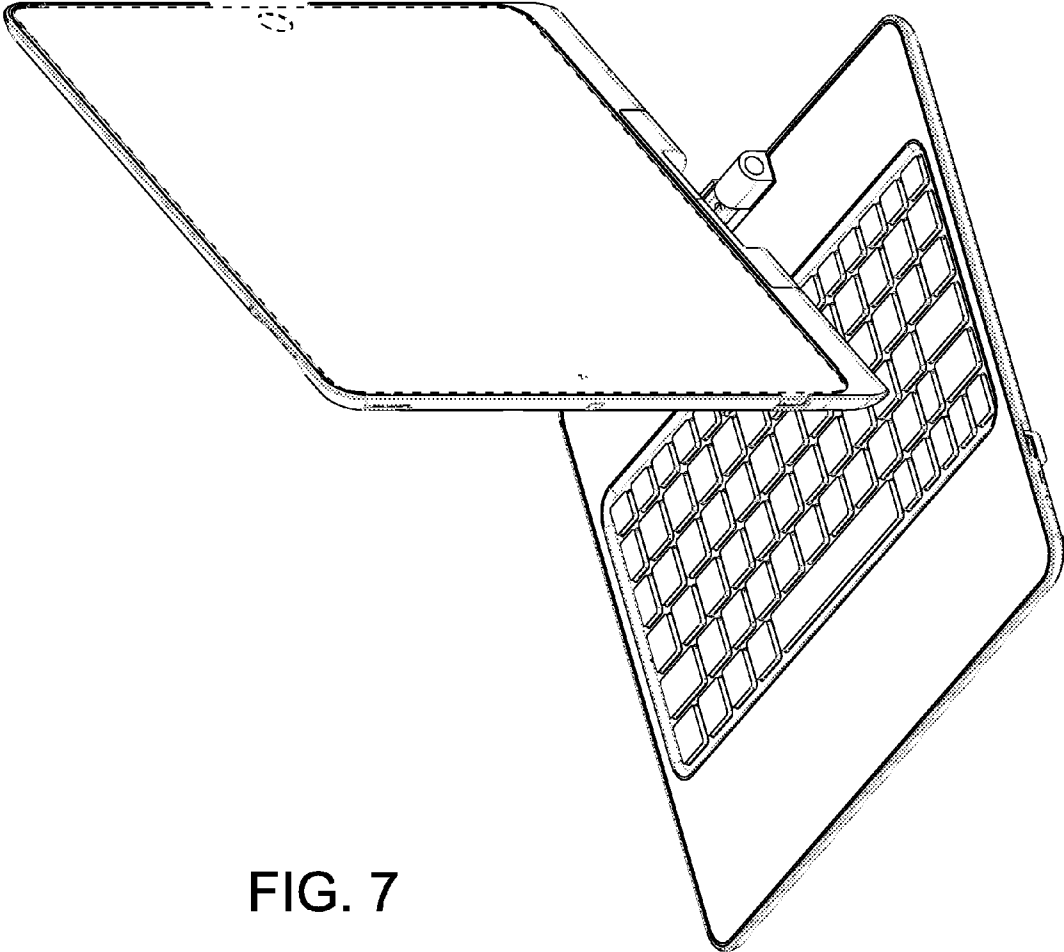

FIG. 7

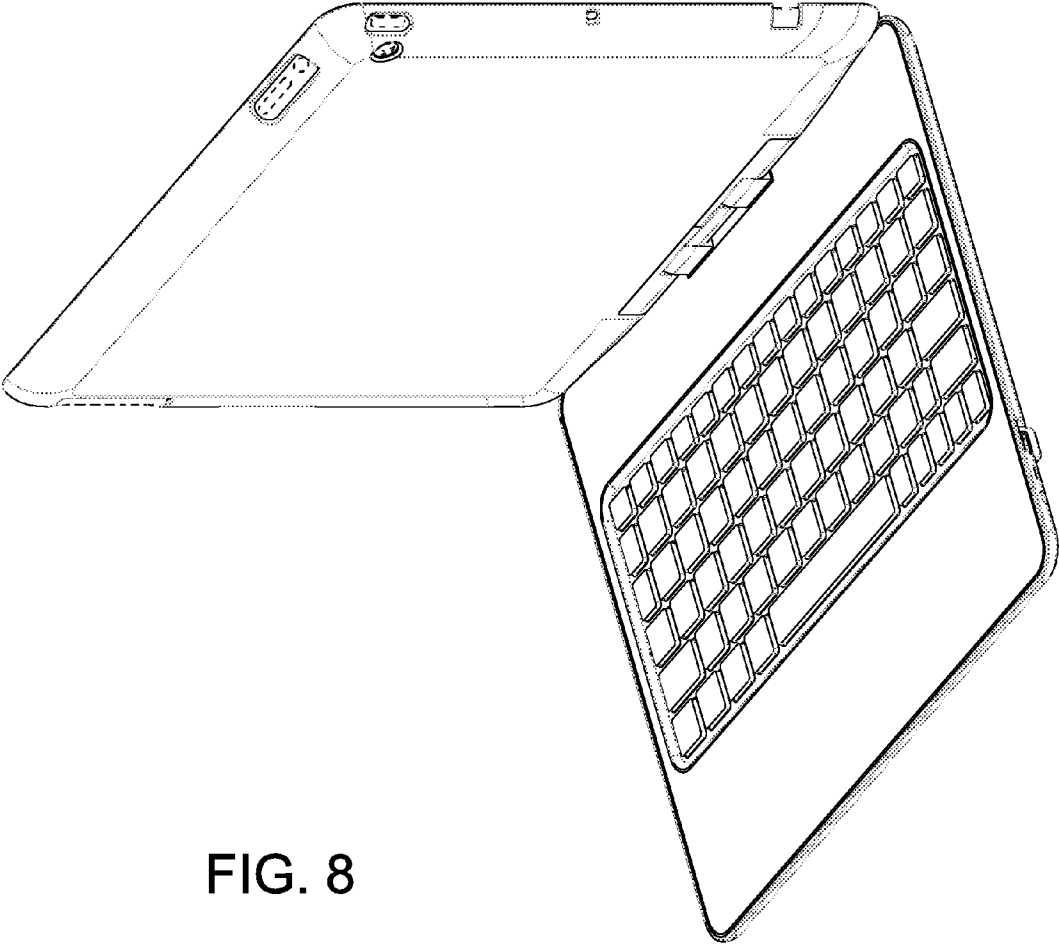

FIG. 8

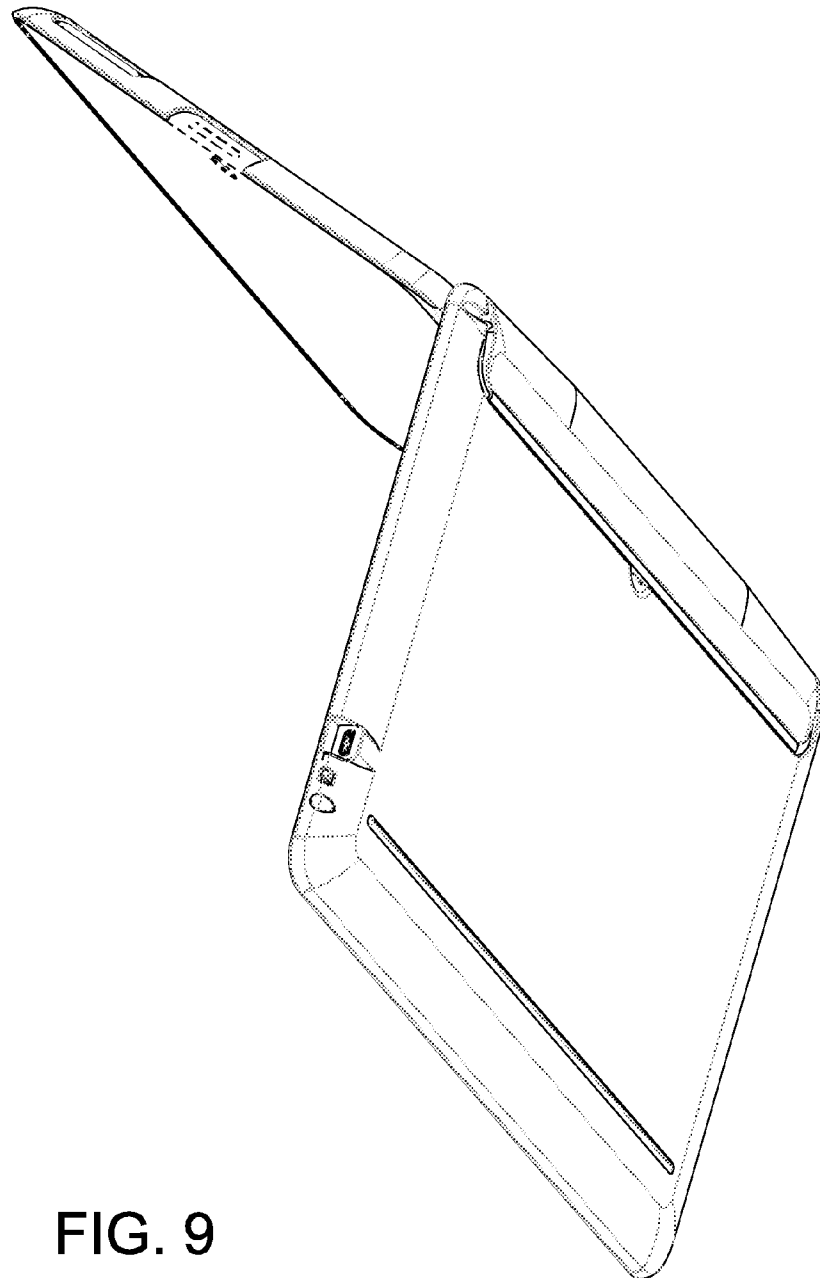

FIG. 9

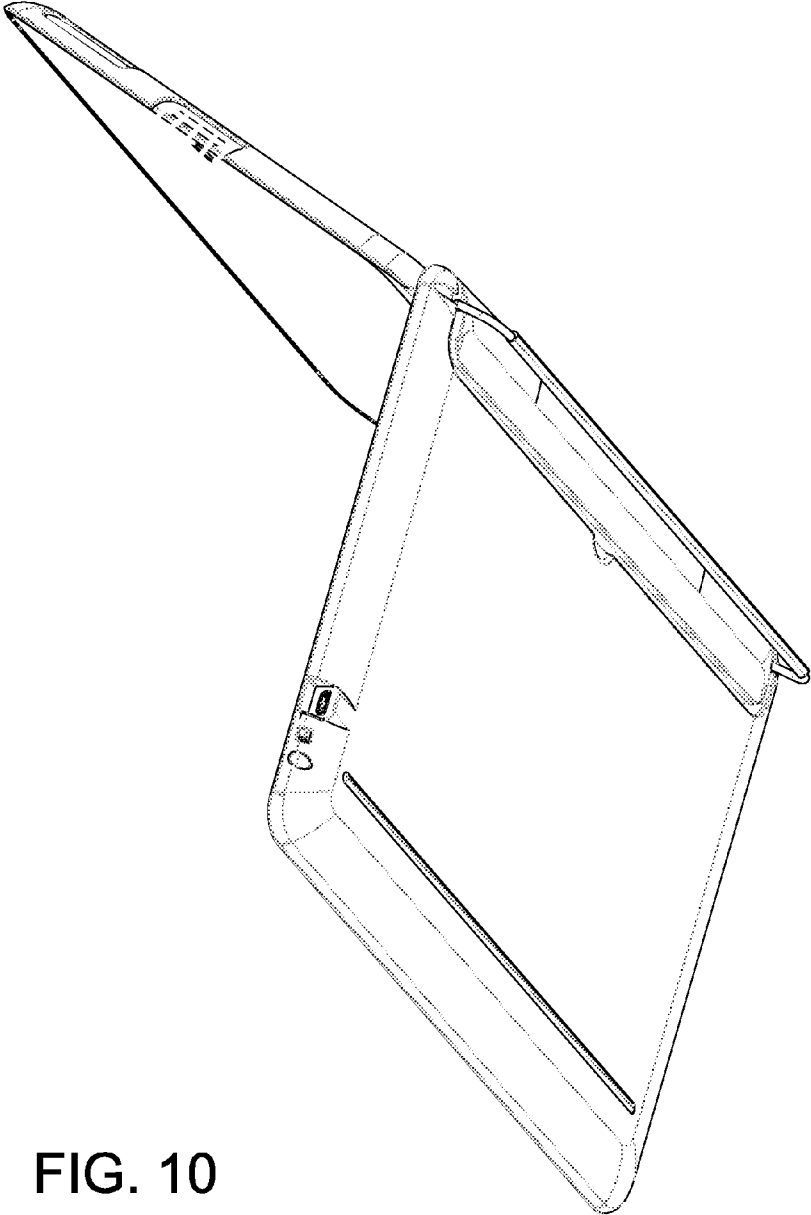

FIG. 10

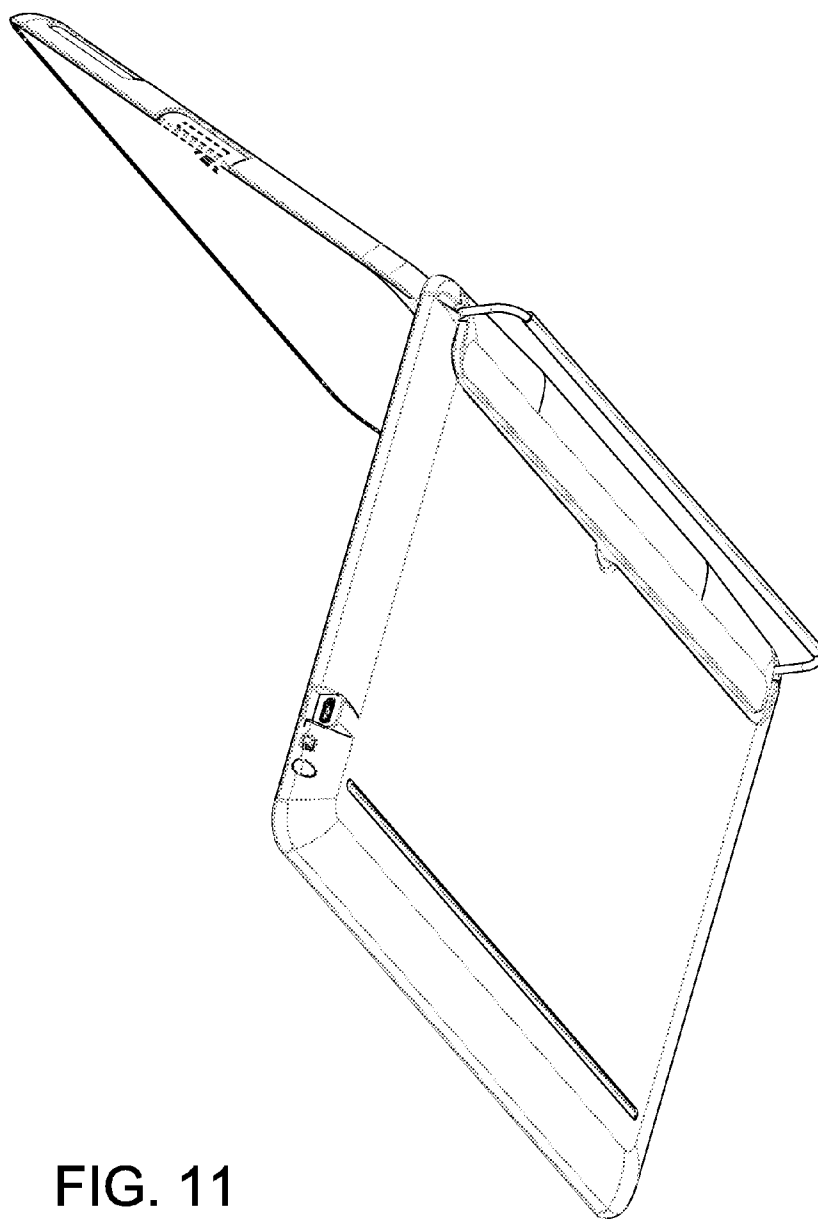

FIG. 11

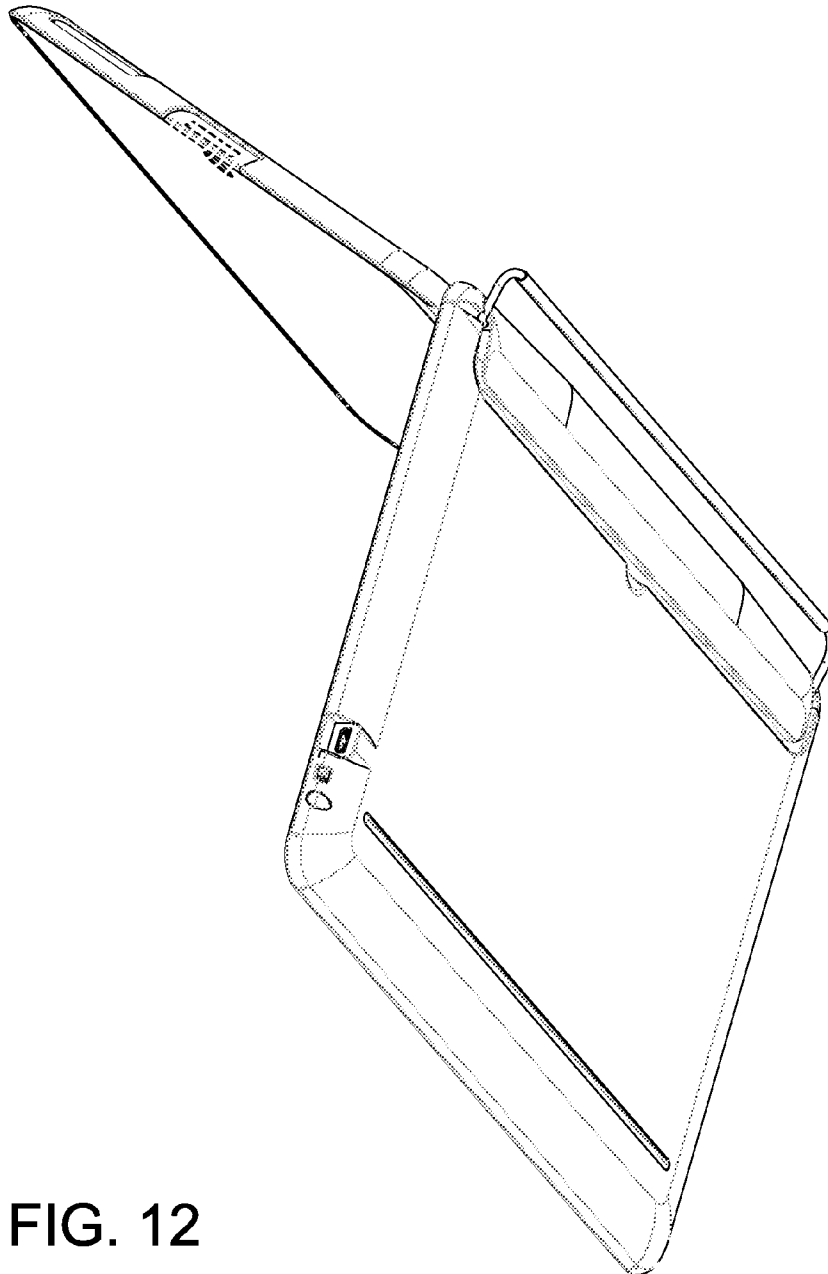

FIG. 12

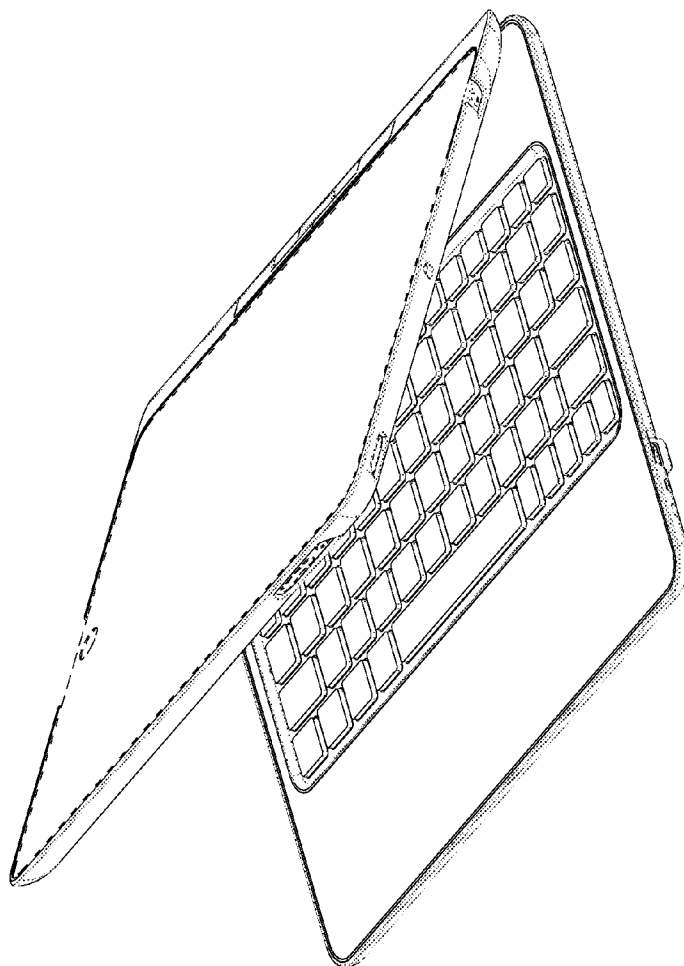

FIG. 13

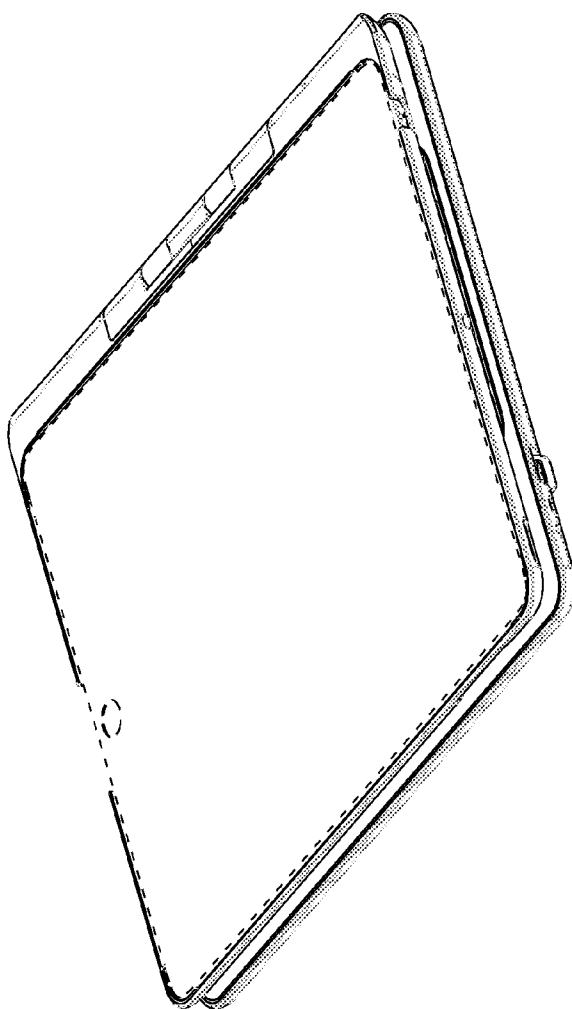

FIG. 14



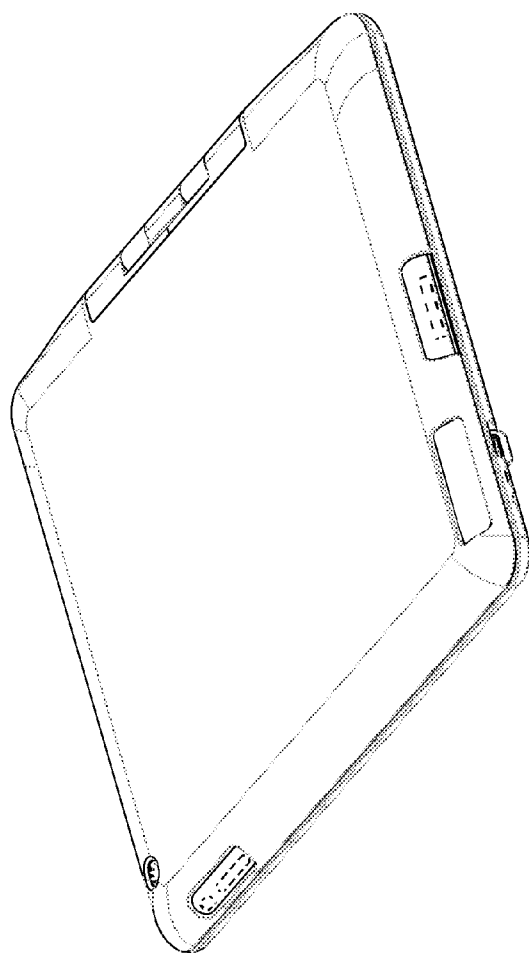

FIG. 15