

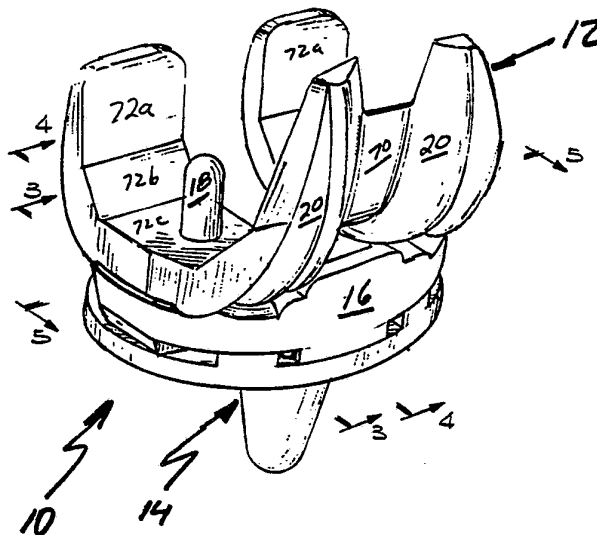

INTERNATIONAL APPLICATION PUBLISHED UNDER THE PATENT COOPERATION TREATY (PCT)

<p>(51) International Patent Classification ⁵ : A61F 2/38</p>	<p>A1</p>	<p>(11) International Publication Number: WO 92/08424 (43) International Publication Date: 29 May 1992 (29.05.92)</p>
<p>(21) International Application Number: PCT/US91/08520 (22) International Filing Date: 14 November 1991 (14.11.91) (30) Priority data: 613,331 14 November 1990 (14.11.90) US (71) Applicant: ARCH DEVELOPMENT CORPORATION [US/US]; 1115-25 East 58th Street, Chicago, IL 60637 (US). (72) Inventors: POTTENGER, Lawrence ; 1038 E. 48th Street, Chicago, IL 60615 (US). DRAGANICH, Louis, F. ; 5619 South Dorchester, Chicago, IL 60637 (US). (74) Agent: SCHNEIDER, Robert, J.; McDermott, Will & Emery, 227 West Monroe Street, Chicago, IL 60606-5096 (US).</p>		<p>(81) Designated States: AT (European patent), AU, BE (European patent), CA, CH (European patent), DE (European patent), DK (European patent), ES (European patent), FR (European patent), GB (European patent), GR (European patent), IT (European patent), JP, LU (European patent), NL (European patent), SE (European patent).</p> <p>Published <i>With international search report. Before the expiration of the time limit for amending the claims and to be republished in the event of the receipt of amendments.</i></p>

(54) Title: IMPROVED FLOATING BEARING PROSTHETIC KNEE



(57) Abstract

A semiconstrained prosthetic knee for surgical replacement of a dysfunctional knee includes a tibial platform (22), a movable bearing element (16), and a femoral component (12). The femoral component (12) includes a polycentric convex bearing which slidably engages a movable bearing (16). The superior surface of the bearing element (16) is designed to congruently slidably engage the inferior surface of the bearing portion of the femoral component (12). The inferior surface of the femoral component (12) is generally convex with two or more offset portions of varying radii of curvature matching complementary superior surfaces of the bearing element (16). The inferior surface of the femoral component (12) may have more than one radius of curvature at different points along the convex surface. The superior surface of the tibial platform (22) is generally flat and includes at least one protrusion for controlling the movement of the bearing element (16).

FOR THE PURPOSES OF INFORMATION ONLY

Codes used to identify States party to the PCT on the front pages of pamphlets publishing international applications under the PCT.

AT	Austria	ES	Spain	MG	Madagascar
AU	Australia	FI	Finland	ML	Mali
BB	Barbados	FR	France	MN	Mongolia
BE	Belgium	GA	Gabon	MR	Mauritania
BF	Burkina Faso	GB	United Kingdom	MW	Malawi
BG	Bulgaria	GN	Guinea	NL	Netherlands
BJ	Benin	GR	Greece	NO	Norway
BR	Brazil	HU	Hungary	PL	Poland
CA	Canada	IT	Italy	RO	Romania
CF	Central African Republic	JP	Japan	SD	Sudan
CG	Congo	KP	Democratic People's Republic of Korea	SE	Sweden
CH	Switzerland	KR	Republic of Korea	SN	Senegal
CI	Côte d'Ivoire	LI	Liechtenstein	SU ⁺	Soviet Union
CM	Cameroon	LK	Sri Lanka	TD	Chad
CS	Czechoslovakia	LU	Luxembourg	TG	Togo
DE*	Germany	MC	Monaco	US	United States of America
DK	Denmark				

⁺ Any designation of "SU" has effect in the Russian Federation. It is not yet known whether any such designation has effect in other States of the former Soviet Union.

IMPROVED FLOATING BEARING PROSTHETIC KNEE

BACKGROUND OF THE INVENTION

1. FIELD OF THE INVENTION

This invention relates to prosthetic joints generally, and more particularly to an improved, unconstrained prosthetic knee replacement for a dysfunctional knee.

2. PRIOR ART

Referring now to prior art knee endoprostheses, there are basically two types of prosthetic replacement knees known generally as constrained and unconstrained knees. An example of an unconstrained or floating meniscal bearing knee is disclosed in Buechel et al Patent No. 4,340,978. An embodiment of the Buechle invention is manufactured and sold by Depuy, Inc. of Wausau, Indiana. Preferably, the bearing elements of these types of knees are manufactured with high density polyethylene such as that disclosed in Zachariades Patent No. 4,587,163 developed by Polteco Inc. of Alameda, California because of its superior wear resistant characteristics. Both classes of prior art prosthetic knees have had problems often resulting in failures requiring additional surgery and repair or reconstruction.

Referring next to typical prior art tibial-femoral knee prostheses, prostheses which allow axial rotation and A-P motion in addition to flexion-extension motion have incongruent contact (usually theoretical point-contact) between the femoral and tibial bearing surfaces, have been found to produce excessive contact stresses leading to deformation and/or early wear and undesirably short prosthetic life. Also, wear

products have been shown to produce undesirable tissue reactions which may contribute to loosening of the prosthetic components.

Those prior art knee prostheses which do provide congruent or area bearing contact fail to provide the needed axial rotation, or when cruciates are present the needed anterior-posterior motion. This lack of axial rotation and anterior-posterior motion has been found clinically and experimentally to result in deformation and loosening of the tibial components, and such prostheses now appear to be falling into disuse.

Pre-existing constrained knees have often resulted in early failure as a result of hinge constraint. The degree of rotation was limited to either only one plane or a very small arc causing a loosening and failure of the connection points between the prosthesis and the tibia or femur. Also, as shown in U.S. Patent No. 4,219,893, very little flexibility was possible in the shape of the patello-femoral interfaces because of the requirement to maintain congruent patello-femoral contact over the range of motion of the knee. As a result, patello-femoral tracking problems became commonplace.

It was necessary to use a large circumference when used to resurface allografts resulting in problems with soft tissue necrosis and/or patello-femoral tracking problems as described above. Furthermore, most implants were known as

custom devices since they had to be specially made to fit a particular patient's size and thus required excess manufacturing time and unnecessary delays.

An additional, significant problem with prior art constrained knees results from the fact that the range of motion prevents the normal A-P movement of the inferior end of the femur relative to the posterior end of the tibia. This "sliding" movement is necessary in order to maintain the full range of motion desired in a prosthetic device.

Current prostheses of the dislocatable cruciate retaining type, such as the Geomedic knee replacement shown in U.S. Patent No. 3,728,742 to Averill et al, that produce area contact provide only one axis of rotation relative to the femur for the flexion-extension motion. Normal flexion-extension is, however, characterized by a polycentric flexion-extension motion where rotation relative to the femur occurs about many axes.

This polycentric motion, which results from the action of the cruciate ligaments and condylar shape, allows for more efficient utilization of muscle forces by providing a posterior shift of the axis when effective quadriceps action is important and an anterior shift when hamstrings effectiveness is important. Furthermore, in the human knee it is this action and the A-P shift, and the shape of the posterior condyles, which influence this motion so as to allow full flexion

capability for the knee. Failure to provide appropriate knee geometry inhibits, when cruciate ligaments are present, this natural motion and thus tends to restrict muscle effectiveness and inhibit flexion. These restrictions tend to increase both loading on the prosthesis (which increases wear or likelihood of deformation or breakage) and loading between prosthesis and bone (which increases the possibility of component loosening).

It has been found that loosening problems result from the direct attachment of plastic prosthetic components to bone through the use of relatively brittle cement that is weak in tension. Specifically, it has been demonstrated that even relatively thick plastic components when loaded in a normal fashion produce undesirable tensile stresses in the acrylic cement commonly used to secure such plastic components to bone. Such loading tends to produce bending of the plastic component which causes the ends of the plastic component to lift away from the bone, thereby subjecting the bone-cement attachment to tension. As is known, cement has very poor tensile fatigue properties. The bone to which the plastic prosthesis is cemented also appears to be adversely affected by tensile loads. Accordingly, these combined effects contribute substantially to prosthetic loosening problems and, specifically, it has been noted where clinical failure due to loosening occurs in a knee prosthesis that is almost always the plastic prosthesis component which loosens.

Another prior art prosthesis problem exists with regard to knee endoprostheses for implantation in those cases wherein the cruciate ligaments are functionally absent but where the collateral ligaments are functional or at least reconstructable. In the absence of cruciate ligaments, the prosthetic replacement must provide anterior-posterior knee joint stability so as to replace that stability otherwise provided by the cruciates. Until recently most such cases were treated by a constrained type knee prosthesis which may suffer from the loosening problems described above caused by the stresses described above. Necrosis of the bone, caused by altered mechanical bone stresses, is also a problem with the prior art constrained knee prostheses.

Where the cruciate ligaments are present, most surgeons would prefer their retention, since they provide important internal stabilizers and, together with the condylar geometry of the femur and tibia, control the rotation axis and A-P motion of the knee. Furthermore, these ligaments provide anterior-posterior stability. Thus, it is desirable to reserve the cruciate ligaments, even though reasonable stability can be provided by a properly designed full platform type prosthesis.

In addition, the action of the cruciate ligaments produces a shift in the rotation axis of the knee which results in more efficient muscle utilization. Thus, preservation of these structures provides better physiological function after knee replacement.

It is not, however, clear that the physiological advantages gained in retaining the cruciates outweigh the disadvantages of the design compromises, such as increased bearing surface incongruency and reduced tibial prosthesis bearing area, required to retain these ligaments. Thus, the desirability of retaining the cruciate ligaments in the cases of unconstrained knee replacement is not well established.

A recent unconstrained knee concept, the New Jersey knee, appears to provide a partial solution to the problem of overconstraint while attempting to maintain congruency by the use of mensical floating elements. Unfortunately, this knee suffers from several design problems which appear to limit its usefulness.

The present invention, the Pottenger/Draganich Knee utilizes new concepts combined in an improved design in order to avoid some of the anticipated difficulties of the prior art design.

SUMMARY OF THE INVENTION

The present invention is directed to an improved prosthesis for the replacement of all or a portion of a dysfunctional human knee joint.

An object of the present invention is to provide an improved semiconstrained knee prosthesis with a novel polycentric femoral component having different radii of curvature in different sagittal sections.

An object of the present invention is to provide a knee prosthesis which facilitates rotation about one or more axes in the presence of congruency of the bearing surfaces.

A further object of the present invention is to provide a knee prosthesis which substantially reduces the possibility of tipping and/or dislocation of the bearing insert or inserts in the absence of the anterior and posterior cruciate ligaments.

A further object of the present invention is to provide a knee prosthesis which allows full flexion of the reconstructed knee without applying shear forces.

A further object of the present invention is to provide a knee prosthesis where the tibiofemoral area contact controls the movement of the femoral component and thus increases quadriceps effectiveness.

An object of the present invention is to provide a knee prosthesis in which A-P sliding of the bearing element with knee flexion allows the normal anatomical shift in the center of the area of contact between femoral and tibial condyles.

A further object of the present invention is to provide a knee prosthesis with improved medial-lateral stability, substantially unaffected by axial rotation or anterior-posterior (A-P) shift of the bearing element.

A further object of the present invention is to provide a knee prosthesis which includes constraints at the

limits of normal motion to compensate for missing cruciate ligaments and prevent dislocation.

A further object of the present invention is to provide a semiconstrained knee prosthesis where the femoral component may articulate in extremely close proximity with the tibia to eliminate patella baha problems.

In accordance with the foregoing and other objects, the unconstrained prosthetic knee of the present invention includes a femoral prosthesis having a condylar portion with at least two saggittally spaced arcuate segments of different radii, a tibial prosthesis having a bearing surface for supporting weight, and an intermediate load-bearing member having a thrust-bearing surface for matingly engaging the bearing surface of the tibial prosthesis and adapted to distribute weight and to transmit forces in a plane substantially perpendicular to the axis of the tibia and a mutually congruent superior surface for engaging the condyles of the femoral prosthesis to provide area contact throughout the full range of flexion/extension of the knee.

BRIEF DESCRIPTION OF THE DRAWINGS

A complete understanding of the invention may be obtained from the detailed description which follows, together with the accompanying drawings, wherein:

Fig. 1 is a perspective view of the unconstrained prosthetic knee of the present invention;

Fig. 2 is an exploded perspective view of the tibial component and bearing element of the prosthetic knee of the present invention;

Fig. 3 is a vertical section taken generally along the line 3-3 of Fig. 1;

Fig. 4 is a vertical section taken generally along the line 4-4 of Fig. 1;

Fig. 5 is a vertical section taken generally along the line 5-5 of Fig. 1;

Fig. 6 is a top plan view of the bearing element made in accordance with the present invention;

Fig. 7 is a front elevational view of the bearing element of Fig. 6;

Fig. 8 is a bottom view of the bearing element of Fig. 6;

Fig. 9 is a rear elevational view of the bearing element of Fig. 6;

Fig. 10 is a side elevational view of the bearing element of Fig. 6;

Fig. 11 is a vertical section taken generally along the line 11-11 of Fig. 6;

Fig. 12 is a vertical section taken generally along the line 12-12 of Fig. 6;

Fig. 13 is another vertical section taken generally along the line 13-13 of Fig. 6;

Fig. 14 is a diagrammatic representation of the assembled bearing element and tibia portion showing the bearing element in its forwardmost position;

Fig. 15 is a diagrammatic representation similar to Fig. 14 showing the bearing element in its rearwardmost position;

Fig. 16 is a top plan view of the femoral component on a reduced scale;

Fig. 17 is a vertical section taken generally along the line 17-17 of Fig. 16;

Fig. 18 is a front elevational view of the prosthesis assembly implanted within a patient;

Fig. 19 is a rear elevational view of the prosthesis assembly implanted within a patient;

Fig. 20 is a side elevational view of the prosthesis assembly in a generally, straight extended position; and

Fig. 21 is a diagrammatic representation of the prosthesis assembly with the knee shown in flexion.

BRIEF DESCRIPTION OF THE PREFERRED EMBODIMENT

The floating bearing prosthetic knee, generally designated 10 in Fig. 1, provides area contact as opposed to line contact or point contact throughout the entire

flexion/extension range of the prosthesis. Through this design, some degree of rollback automatically occurs as the knee flexes and additional rollback is allowed to will occur through the movement of the sliding bearing. Area contact throughout the full range of motion is obtained through the use of multiple arcuate sections along the path of conduct of the condyles with the bearing insert. However, unlike prior art prosthetic knees of the prior art, the different radii and arcuate portions of the condyles lie in different saggital or medial-lateral planes. Thus tibial-femoral area contact will occur in different longitudinal planes throughout the flexion/extension range of the knee. Area contact will occur simultaneously in two planes only at the point of transition between the respective arcuate portions.

The desirable prosthetic knee 19 satisfies at least five characteristics. One, the knee should have the normal polycentric motion of the normal knee joint. Two, unconstrained anterior-posterior motion and rotation would be permitted within the normal range of motion of the knee. Three, constrained A-P motion and rotation would occur at the limits of normal motion. Four, normal rollback of the femur with respect to the tibia should occur during flexion of the knee. Five, tibial-femoral contact pressure should be minimized in order to reduce wear on the polyethylene bearing insert 16. The present invention 10 satisfies these five characteristics as described hereinafter.

MAJOR COMPONENTS

Referring now in particular to Fig. 1, the unconstrained knee, generally designated 10, is shown in perspective view to include a femoral component 12, a tibial component 14, and a bearing element 16. The femoral component 12 includes at least one upwardly extending stem 18 or other means for connection to the femur and a pair of condyles 20 on its inferior surface for engagement with the bearing portion 16. Preferably, the bearing element 16 is constructed of a tough, wear-resistant, resilient material such as high density polyethylene. The remaining elements of the prosthetic knee are metallic and preferably manufactured of a cobalt-chromium alloy material approved for use in prosthetic devices.

THE TIBIAL COMPONENT

The tibial component includes a generally flat rigid platform 22 and a depending stem portion 24 for securing the tibial portion to the tibia. The superior surface of the femoral component and the implantable stem portion 24 and inferior surface of the platform 22 of the tibial component include a surface adapted for extramedullary porous ingrowth to secure the prosthetic device within the tibia and femur, respectively, of the host or allograft bone of the patient. By contrast, the condyles 20 of the femoral component are highly polished to reduce friction.

Referring to the lower portion of Fig. 2, the tibial portion includes the platform 22 and the depending stem 24. The platform is provided with a pair of laterally spaced, generally triangular-shaped, upward protrusions 26 and a centrally located aperture 28 for limiting the A-P movement of the bearing 16 described below.

More particularly, referring to Figs. 2, 5 and 6, the bearing 16 includes a centrally located generally rectangular opening 32 which is used to slidably connect the bearing to the top of the tibial component 22. The bearing 16 has a generally flat inferior surface 34 as shown in Fig. 8 which slidably engages the superior surface of platform 22. The aperture 32 includes, at its lower end, a ridge or lip 36, of similar configuration. Both the aperture 32 and the vertical wall of the bearing have smooth or rounded corners to reduce stress. The bearing 16 is captured by a retaining means, generally designated 40, which includes a shoulder bolt 42, a retainer 44 and a spacer 46. The spacer 46 and retainer 44 are preferably manufactured of high density polypropylene, similar to that used for the bearing insert 16 and the shoulder bolt 42 would be made of stainless steel or cobalt-chromium alloy approved for use in this application.

The shoulder bolt 42 includes a lower threaded portion 48 which engages a plurality of threads 50 at the lowermost end of the aperture 28 within the stem 24 of the

tibial component. The shoulder sets the depth to prevent from the head 52 of the shoulder bolt from impeding the movement of the bearing insert 16. The retainer 46 includes an enlarged diameter ring 54 at its lowermost end which engages the platform 22 of the tibial portion 14 around the aperture 28 and extends upwardly coaxially with the shoulder bolt 42.

The retainer or retaining element 44 is generally square in shape and includes a lower square portion 56 which forms a clearance fit within the ridge 36 at the lower end of the aperture 32 in the bearing, as can be seen in Fig. 5. The upper end of the retainer includes an enlarged flange 58 which engages the top of the step or lip 36. The retainer 44 is dimensioned so that the distance between the underside of the head 52 of the shoulder bolt and the top of the lip 36 provides a low tolerance clearance fit with the flange 58 of the retainer to allow the bearing 16 to slidably move on the platform 22 without becoming disengaged from the platform 22. In this manner, the bearing is free to slide in an anterior posterior or A-P path. The retainer 44 will stop the movement in the A-P direction as the front and rear surfaces engage the front or inner surfaces of the lip 36.

The retaining means 40, in addition to permitting A-P movement of the bearing 16 also permits pivotal movement generally about the center line of the shoulder bolt 42. Thus, depending upon the anterior or posterior displacement of the

bearing insert 16 relative to the retainer 44, the bearing insert and the retainer may pivot about the center line of the shoulder bolt 42 to provide freedom of movement. However, in order to prevent too much pivotal movement of the bearing 16, particularly when in its anteriormost position, the triangular protrusions 26 provide a stop means.

The stop means includes the upward protrusions 26 and a pair of symmetrical cutouts 60 on the lower surface of the bearing insert 16. In particular, each cutout includes a generally flat rear wall 62 and a generally curved inner wall 64 for engagement with the upward protrusions 26. As shown in Fig. 4, the height of the rear wall 62 permits the cutouts 60 to clear the top of the stops 26. Referring to Fig. 14, in its anterior-most position, the arcuate walls 64 of the bearing 16 engage the inner, generally right angle corner of the triangular protrusions 26 to virtually preclude most of the pivotal movement or rotational movement of the bearing insert 16. As the bearing 16 is moved towards its posterior-most position, as shown in Fig. 15, the bearing is free to rotate in either direction as shown by arrows A and B and are limited by the longer upstanding walls of the protrusions 26 which engage the flat walls 62 within the cutout 60.

Therefore, it can be seen that the bearing insert 16 is constrained but is permitted to move in the A-P direction from the extremes as shown in Fig. 14 to that as shown in Fig.

16 while, at the same time, it is free to pivot about an axis defined by the shoulder bolt 24 within the limits created by the stop means where the walls 62 and 64 of the cutouts 60 engage the triangular protrusions 26. These constraints, while permitting movement of the bearing 16, control the movement of the femoral component as described hereinafter and thus create some rollback and allow for the further posterior movement of the bearing insert.

These constraints at the limits of normal motion will compensate for missing cruciate ligaments and prevent dislocation of the components, i.e., the bearing insert, which has been seen to occur in popular prior art floating bearing prosthetic knees. In most circumstances, normal soft tissue will provide the primary restraining forces limiting motion of the components and, if necessary, the limits incorporated into the prosthesis 10 would function as secondary restraints.

Some rollback (approximately 5 millimeters in the present embodiment) automatically occurs (i.e., is obligated to occur) when tibiofemoral contact moves from one arcuate segment to the other one. The rest of the normal amount of rollback is allowed to occur (but not obligated to occur) with the movement of the bearing insert. The amount of additional rollback that is allowed to occur is governed by the interaction of the posterior cruciate ligament and the condylar surfaces. The rollback of the femur with respect to the tibia during flexion

of the knee is an important characteristic of the present prosthesis because it causes the patellar tendon to move anteriorly with respect to the femur which greatly increases the effectiveness of the quadriceps muscle, especially when rising from a chair. It has been found that many patients who have had total knee replacements cannot get up from a sitting position without assistance from their arms. Also, prior arm unconstrained knees are frequently found to "roll forward" rather than backward during flexion. In the design of the present invention, the shoulder bolt retaining means 40 prevents roll forward and the bearing insert 16 recreates the normal situation and further helps to increase the quadriceps efficiency. Known prior art total knee replacements have attempted to utilize the femoral component to control the motion of the bearing insert, just the opposite of the knee of the present invention.

THE FEMORAL COMPONENT

The femoral component 12 of the present invention includes generally a pair of condyles 20, securing posts 18 and a web portion which defines a patella track 70. The securing posts 18 provide means to secure the femoral component to the femur of a patient. As shown in Fig. 20, a pair of matched apertures are drilled into the femur and the end of the femur is formed with five generally flat surfaces as shown to fit

within the flat surfaces 72a through 72e as shown. The opposite surfaces 72a and 72e are generally parallel to one another and perpendicular to the surface 72c. The angled surfaces 72b and 72d are approximately at 45 degrees with respect thereto. The entire surface of the flat surfaces 72a-e and the surfaces of the posts 18 are designed for extramedullary bone growth to secure the femoral component to the end of the femur.

Certain prior art prostheses propose the use of a femoral component in which the multicentric surfaces of the condyles were created by a common planar curve which created a design whereby every sagittal section along the condyle was polycentric. This design results in a situation where the condyles can only make area contact during approximately the initial 20° of knee flexion thereby resulting in line contact and very high contact pressure which increases the wear of the bearing insert. In addition, prior art design of this type accomodates rollback of the femur with respect to the tibia and, particularly at maximum flexion, there is a tendency for the bearing insert to "pop out" or become dislocated.

The femoral component and sliding bearing of the present invention have congruent surfaces which allows for rotation and A-P motion within the range of normal A-P motion to prevent excessive anterior and posterior drawer and rotation and dislocation of the bearing. The upper surface of the

bearing 16 is designed so that the inferior surfaces of the femoral component always have area contact at all flexion angles. Constant area contact is achieved by distributing the femoral contact areas on the bearing 16 across the frontal plane such that different areas of the bearing 16 are contacted through different angles of knee flexion. Each contact area on the bearing has the same radius of curvature as the portion of the inferior surface of the femoral component 12 in contact with the bearing.

THE BEARING INSERT

Referring to Figs. 6-13, the bearing insert 16 is generally oval in shape with a pair of flat ends 80R and 80L. The anterior or front side is a generally flat arcuate wall 82 which includes a pair of cutouts 60 at the lower right and left ends, respectively. The posterior side includes a relatively large, almost semicircular recess 84 which provides substantial clearance for the posterior cruciate ligaments. The top portion of the rear wall on either side of the recess 84 includes a short generally vertical arcuate wall portion 86 which merges into a generally arcuate, inwardly tapered lower wall portion 88. The tapered portions 88 merge with a pair of lower chamfers at the bottom of the end walls 80R and 80L which terminate at their front ends with the cutouts 60.

The superior surface of the bearing insert is described by a plurality of arcuate channels or grooves which are described in detail hereinafter in connection with the arcuate surfaces defined on the inferior contact surface of the femoral component. In order to add rigidity to the front wall portion 82, an upstanding flange 96 is included immediately anteriorly of the aperture 32. The outer edges of the top of the front wall 82 are softened by curves 98 as the transition to the top of the bearing insert 16.

CONTACT SURFACES

The contact surfaces between the bearing insert 16 and the femoral component 12 are best understood if considered together. The upper surface of the bearing 16 includes a plurality of arcuate surfaces for engagement with congruent arcuate surfaces on the inferior side of the femoral component 12. Referring to Fig. 6, four of the arcuate surfaces have been labelled L and two of the surfaces have been labelled S. The four arcuate surfaces L are all generated using the same radius of curvature and similarly the two arcuate surfaces labelled S are generated using the same but smaller radius. The arcuate surface S shown in section view in Fig. 12 is defined posteriorly of the arcuate surfaces L, one of which is shown in sectional view in Fig. 11. As can be seen in Fig. 5, the complementary surface of the femoral component includes

four arcuate surfaces L and two arcuate surfaces S. One significant feature of the present invention is that the arcuate surfaces L and R lie in different saggital planes as shown and make contact during different degrees of flexion of the knee.

In particular, the arcuate surfaces L on the inferior surface of the femoral component are in contact with the arcuate surfaces L on the bearing 16 between approximately 0° through 8° of flexion of the knee and the arcuate surfaces S of the femoral component are in contact with the arcuate surfaces S of the bearing 16 during approximately 8° through 140° of flexion of the knee. At the transition point, at approximately 8° of flexion, area contact occurs between all of the arcuate surfaces L and S on the femoral component 12 with all of the arcuate surfaces L and S on the bearing component 16.

Although the size of the patient will partially determine the size of the prosthesis, the following sizes have been found to be effective in trials. More particularly, referring to Fig. 3, the arcuate surfaces L are generated by radius R1 about a center point C. Center point C is slightly rearwardly defined relative to the post 18 and the radius R1 is approximately 1.60". The arcuate surfaces S are generated by a radius R2 about a center of rotation D. The radius R2 is approximately 0.75". The center of rotation D of radius R2 lies on a line passing through the center of rotation C of R1

so that the surfaces L and R have a tangent point T in order to have a smooth transition of tibia-femoral contact at approximately 8° of flexion. Thus, area contact of the arcuate surfaces L occurs during the first 8° of flexion of the knee and area contact is transferred to the arcuate sections S at approximately 8° and continues through maximum flexion of about 140°.

The position of the femoral component 12 with regard to the bearing 16 is controlled by the center of rotation of curvature for the arcuate surfaces S or L which are in contact. The arcuate curves S are placed farther back on the bearing and will draw the femoral component posteriorly thus allowing obligatory rollback. Further rollback is permitted because the elongated aperture 32 in the bearing allows the bearing to move posteriorly on the tibial platform. As described previously, the constraints 26 and the retaining means 40 prevent anterior movement of the bearing 16 beyond the anterior edge of the tibial component. Therefore, when rollback is occurring during flexion of the knee, no compensatory roll forward will occur between the bearing 16 and the tibial component 14. As the femoral component passes through approximately the 8° range, area contact is transferred between the arcuate surfaces L to the arcuate surfaces S, the transition continues smoothly because of the common tangent point of the respective arcuate surfaces. The constraints as

previously described with respect to the bearing 16 prevent dislocation of the bearing element when implanted.

In an alternative embodiment, it is possible to obtain the same functionality and operation if, for example, the innermost or outermost complementary arcuate surfaces L were eliminated. However, additional area contact can be obtained to decrease the pressure between the femoral component and the bearing by providing the additional arcuate surfaces L adjacent the center aperture 32.

In addition, the arcuate surfaces L and S are designed to obtain the maximum amount of area contact possible within the permissible space. To this end, the arcuate surfaces S on the bearing 16 are approximately $3/8$ " wide and approximately $1-1/8$ " long. As described previously, the radius R_2 , the radius for generating the arcuate surface S is approximately 0.75 " and lies in a sagittal plane. The transverse radius which defines the arcuate surface in the medial lateral plane as shown in Fig. 5 is approximately $.375$ ". Similarly, the arcuate surfaces L are approximately 1.25 " in length generated by the radius R_1 in the sagittal plane and the radius in the transverse plane R_4 (Fig. 5) which defines a radius of curvature of the arcuate surfaces L in the transverse plane is approximately 0.125 ". The center of rotation D is approximately 0.375 " posteriorly of the center of rotation C and about 0.9 " below the center of rotation C. The center

lines of the arcuate surfaces L are approximately 0.3" on either side of the center line of the arcuate section S and the respective center lines of the arcuate sections S are approximately 2.00" apart.

The knee prosthesis 10 of the present invention is the only design which gives area contact between the bearing 16 and the femoral component 12 in all degrees of flexion. The highest pressures on the knee joint are experienced during stair climbing where the knee is flexed to approximately 90 degrees of flexion in which the prior art knees have only line contact or point contact. Since polyethylene (the material used to form the bearing) wear appears to be related to excessive pressures, area contact is virtually as important in stair climbing as in walking, even though stair climbing is performed much less often. The prosthetic knee 10 also permits the use of the same component in the presence or absence of posterior cruciate ligaments. Generally speaking, semiconstrained knee prosthesis require the presence of posterior cruciate ligaments to prevent posterior subluxation of the tibia. On the other hand, constrained prosthesis, which do not allow rollback, require removal of the posterior cruciate ligaments because proper tension on the posterior cruciate ligaments would attempt to create posterior rollback which is prevented by the constraints. This could lead to dislocation of the components of the constrained prosthesis or rupture of the posterior cruciate ligaments.

In prior art designs in which the arcuate surfaces of the condyles are created by using a common plane generating curve, all of the the sagittal sections of the condyles are polycentric. On the contrary, the present invention has only one radius of contact in each sagittal plane and, therefore, is not created by a common plane generating curve. Since all potential points of contact in the sagittal plane have the same radius of curvature, area contact can be obtained throughout the entire flexion arc of the knee in a manner which cannot be obtained by the prior art knees where the radii along the condyles changes while contacting the same area of the bearing insert.

Referring to Figs. 18-21, which show the prosthetic knee 10 of the present invention implanted in a patient, it can be seen in Fig. 20 that in the extended position of the prosthesis, the bearing insert 16 moves to its anterior-most position with respect to the tibial component 14. In this position, the arcuate surfaces L on the respective tibial component and bearing insert 16 are in engagement. As the knee flexes, rollback of the femur with respect to the tibia begins to occur to approximately the maximum position as shown in Fig. 21 where the bearing insert 16 has moved to its posterior-most position emulating, as close as possible, the normal knee.

Thus, it can be seen that the present invention defines and describes a prosthetic knee which more closely

simulates the normal knee movement than any prior art devices. The prosthesis 10 provides normal polycentric motion for the knee joint and permits normal rollback of the femur with respect to the tibia during flexion. The rotational and anterior-posterior movement of the bearing insert is unconstrained for the normal range of motion but is constrained at its limits. The design of the polycentric contact surfaces between the femoral component 12 and the bearing insert 16 assure for sufficient area contact throughout the flexion/extension range of the knee to minimize pressure and resultant wear on the bearing insert. While the foregoing detailed description has been given for clearness and understanding, no unnecessary limitations should be understood therefrom as some modifications will be obvious to those skilled in the art.

CLAIMS

1. An improved prosthetic device performing a joint between a pair of human or animal bones, comprising:

first attachment means adapted for attachment to one of the bones;

a first bearing surface on said first fixation means, said first bearing surface including at least two, convex, laterally adjacent, arcuate portions of differing radii;

second fixation means adapted for attachment to the other bone;

a second bearing surface on said second fixation means, said second bearing surface lying in a plane generally perpendicular to the axis of said other bone; and

a bearing element between said first bearing surface and said second bearing surface and having a complementary arcuate surface on one side for engaging the first bearing surface and an opposite surface mating in congruent bearing relationship with said second bearing surface.

2. A prosthetic device as claimed in claim 1 wherein said bearing element is freely rotatable through a prescribed arc in a plane approximately perpendicular to the axis of said other bone.

3. A prosthetic device as claimed in claim 1 wherein said second bearing surface is a substantially flat surface substantially perpendicular to the axis of said other bone.

4. A prosthetic device as claimed in claim 1 wherein said second bearing surface is a nearly flat surface of revolution whose axis is approximately parallel to the axis of said other bone.

5. A prosthetic device as claimed in claim 1, wherein said bearing element is freely movable in transverse and rotary directions in said plane approximately perpendicular to the axis of the said other bone.

6. A prosthetic device as claimed in claim 1, wherein said first bearing surface comprises a pair of laterally spaced, arcuate bearing surfaces.

7. A prosthetic knee of claim 1 wherein the first bearing surface has a pair of condylar portions, each condylar portions including two laterally spaced apart condyloid elements each having at least two bearing surfaces defined by laterally spaced, arcuate segments of different radii.

8. A prosthetic device for forming a joint between a pair of human or animal bones comprising:

first fixation means adapted for attachment to one of the bones including a pair of condylar portions;

a second fixation means adapted for attachment to the other bones including a generally flat bearing surface;

an intermediate bearing member, said intermediate bearing member mating with said second fixation means such that said intermediate member and said second fixation means bear on

one another at a mutually congruent thrust bearing surface of revolution for permitting rotational motion between said intermediate member and said second fixation means while force is transmitted therebetween, and permitting sliding motion of said intermediate member relative to said second fixation means.

9. A prosthetic device as claimed in claim 8 wherein said intermediate member in said congruent thrust bearing relationship with said second fixation means is freely movable in a plane approximately perpendicular to the axis of the said other bone while transmitting force to said second fixation means.

10. A prosthetic device as claimed in claim 9 wherein said mutually congruent thrust bearing surface is a nearly flat surface of revolution whose axis is approximately parallel to the axis of said other bone.

11. A prosthetic device as claimed in claim 10 further including stop means for limiting the movement of said congruent thrust bearing.

12. A prosthetic device for joining a pair of human or animal bones comprising:

a first prosthesis having a condylar portion and a fixation portion, said condylar portion including two laterally spaced apart bearing elements each having at least two arcuate segments of different radii, said arcuate segments being adapted to be fixed to one of said bones, said bearing

surface being adapted to support weight or be subjected to force while experiencing relative motion;

a second prosthesis having a bearing surface means for supporting weight and being subjected to force and a fixation portion being adapted to be fixed to the other one of said bones;

an intermediate load bearing member having a thrust bearing surface means for matingly engaging said bearing surface means and adapted to distribute weight and to transmit forces and to rotate freely in a plane substantially perpendicular to the axis of said other one of said bones relative to said bearing surface means while distributing weight and transmitting forces thereto, and an upstanding post extending through an aperture in the load bearing member; and

said mating engagement between said thrust bearing surface means and the arcuate segments being defined by laterally spaced of sufficient magnitude to enable free mobility.

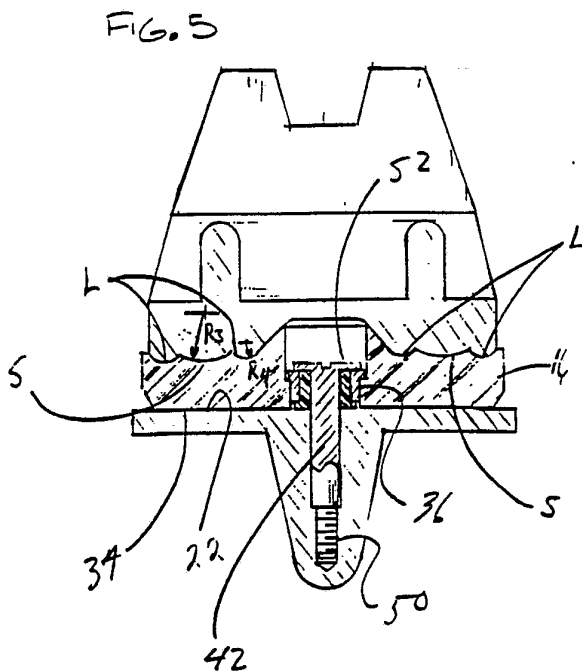
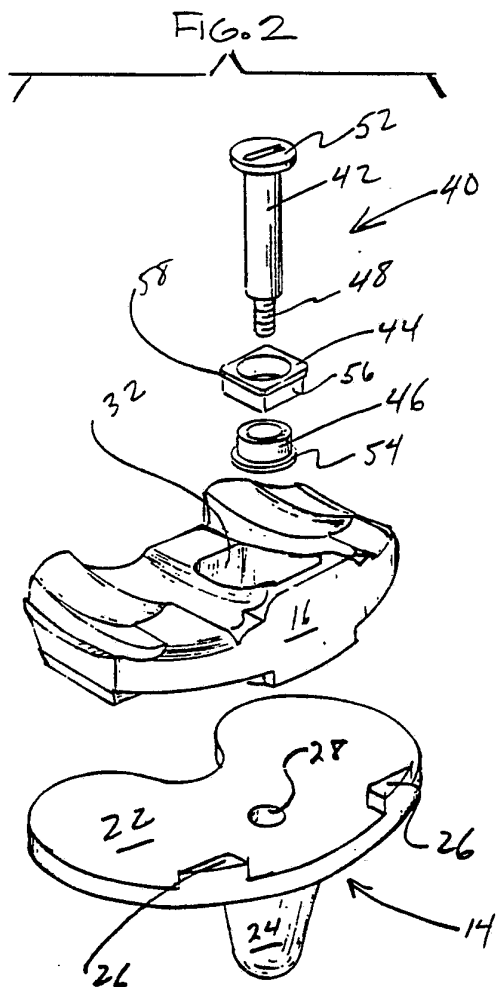
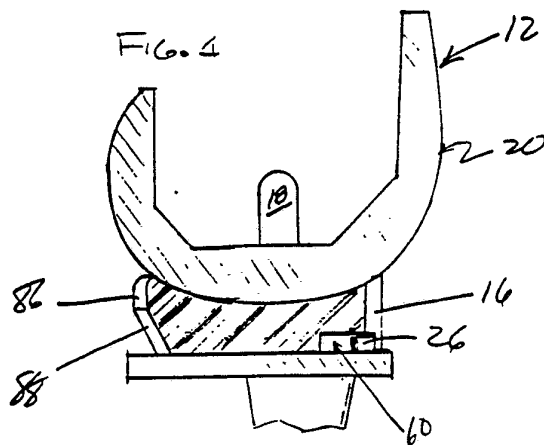
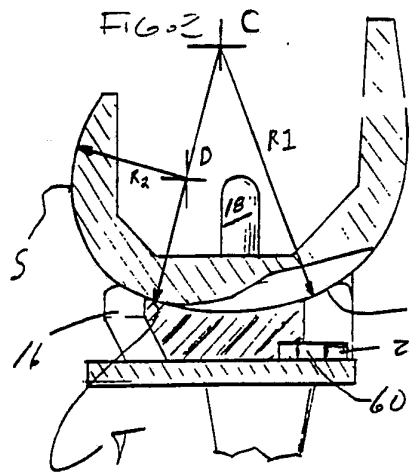
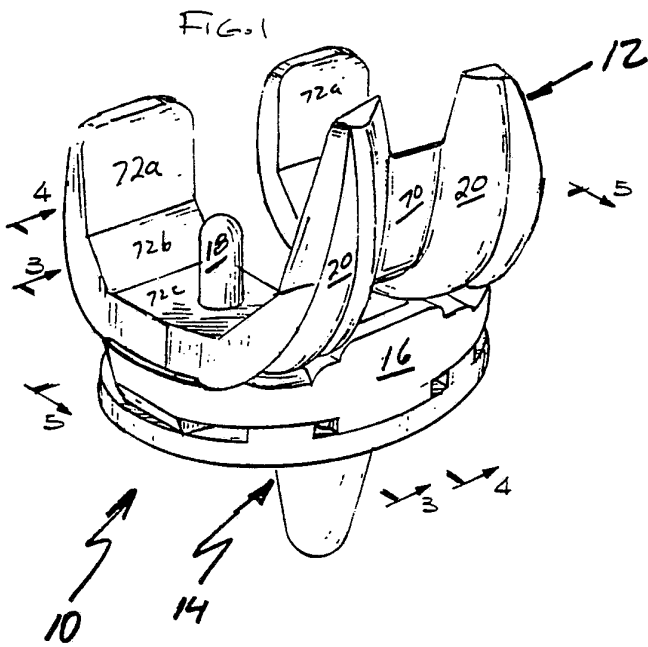

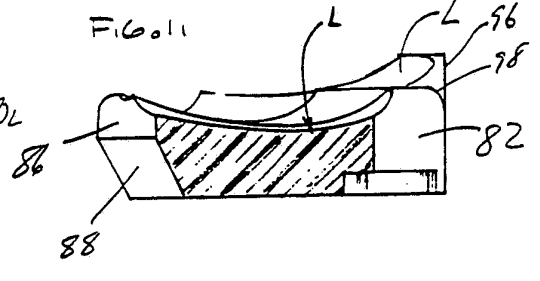
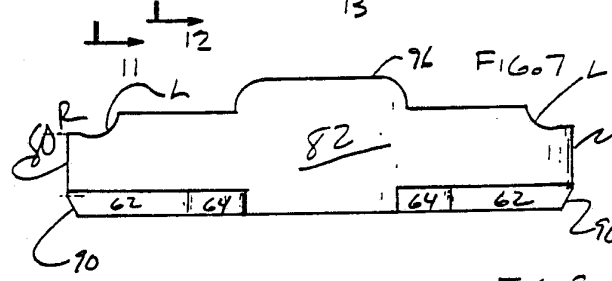
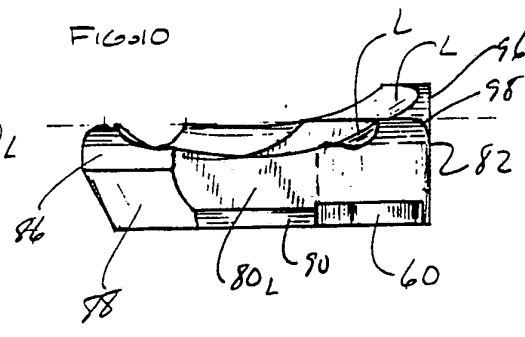
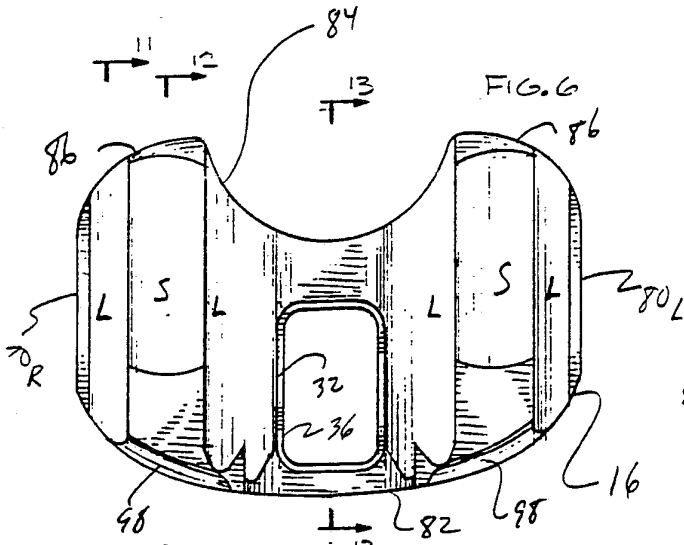
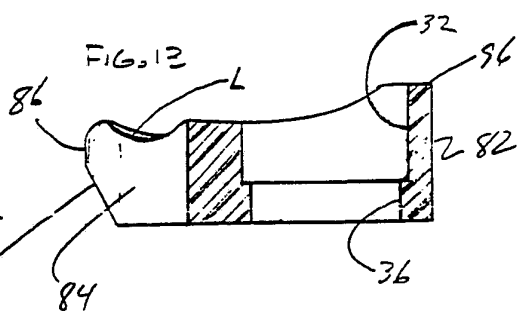
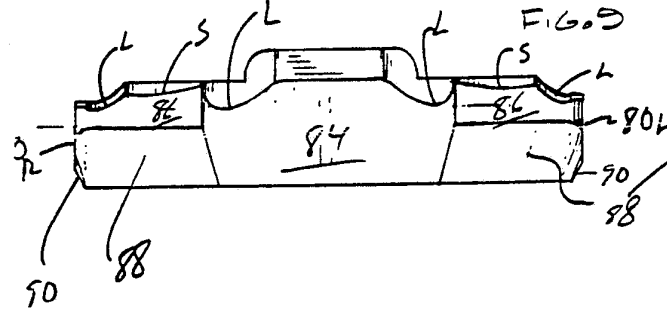
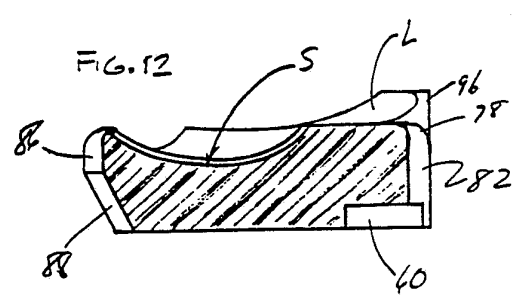
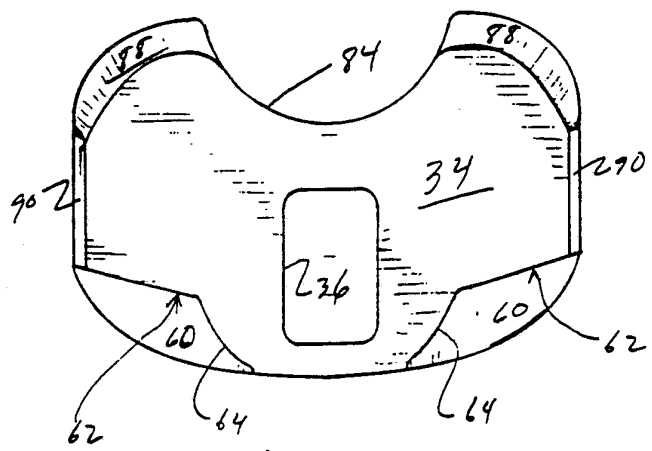
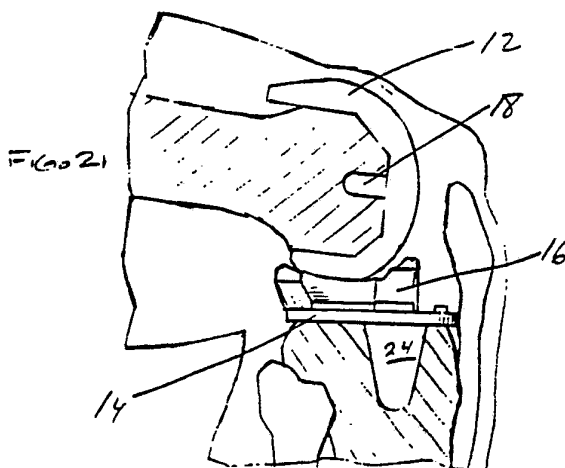
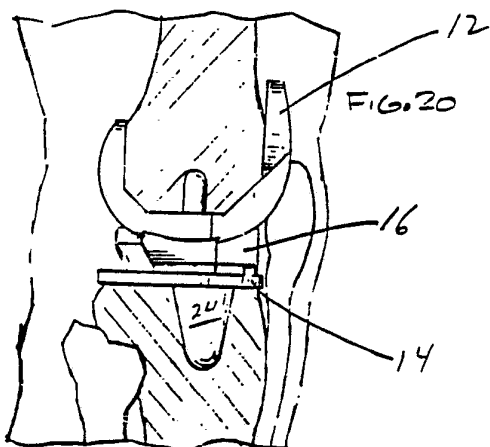
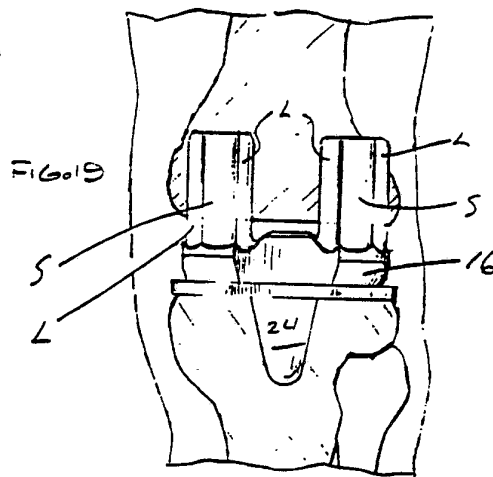
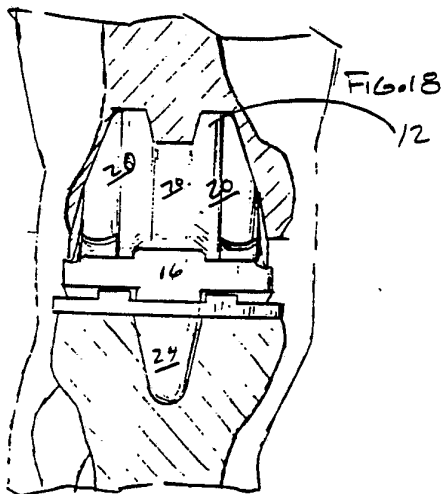
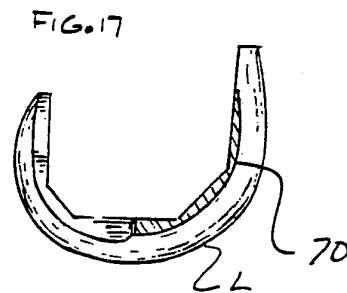
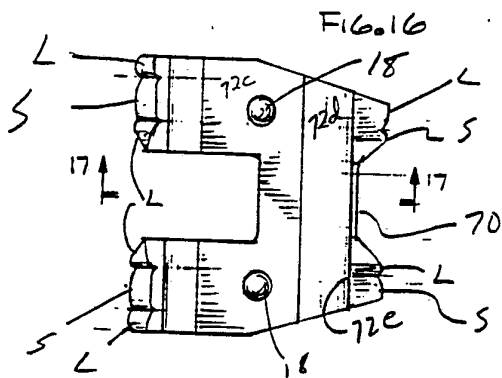
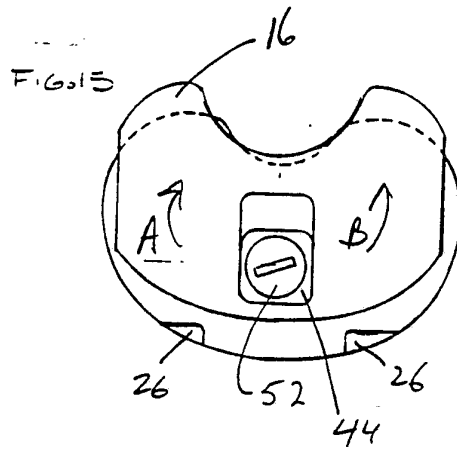
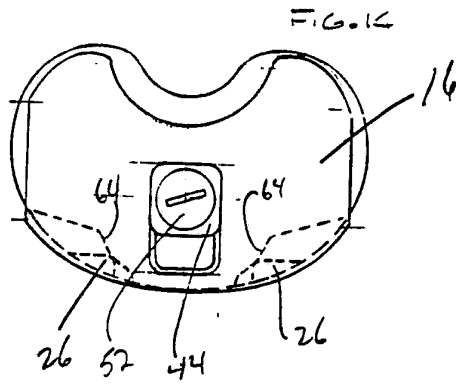

FIG. 8





INTERNATIONAL SEARCH REPORT

International Application No. PCT/US91/08520

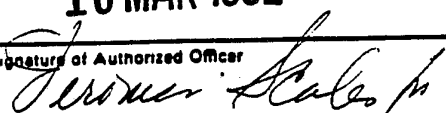
I. CLASSIFICATION OF SUBJECT MATTER (if several classification symbols apply, indicate all) ⁶		
According to International Patent Classification (IPC) or to both National Classification and IPC		
IPC(5): A61F 2/38		
U.S. CL.: 623/20		
II. FIELDS SEARCHED		
Minimum Documentation Searched ⁷		
Classification System	Classification Symbols	
U.S. CL.	623/20, 18, 21, 19	
Documentation Searched other than Minimum Documentation to the Extent that such Documents are Included in the Fields Searched ⁸		
III. DOCUMENTS CONSIDERED TO BE RELEVANT ⁹		
Category [*]	Citation of Document, ¹¹ with indication, where appropriate, of the relevant passages ¹²	Relevant to Claim No. ¹³
X	EP, 0346183 (JUDET) 18 DECEMBER 1989	1, 3, 6, 7
Y	See figure 2 and figure 9	2, 4, 5, 8-12
Y	US, A, 4, 728, 332 (ALBREKTSSON) 01 MARCH 1988 See figure 2 and figure 3 and column 4, lines 23-47	2, 4, 5, 8-12
<p>[*] Special categories of cited documents: ¹⁰</p> <p>"A" document defining the general state of the art which is not considered to be of particular relevance</p> <p>"E" earlier document but published on or after the international filing date</p> <p>"L" document which may throw doubts on priority claim(s) or which is cited to establish the publication date of another citation or other special reason (as specified)</p> <p>"O" document referring to an oral disclosure, use, exhibition or other means</p> <p>"P" document published prior to the international filing date but later than the priority date claimed</p> <p>¹⁴ later document published after the international filing date or priority date and not in conflict with the application but cited to understand the principle or theory underlying the invention</p> <p>^x document of particular relevance: the claimed invention cannot be considered novel or cannot be considered to involve an inventive step</p> <p>^y document of particular relevance: the claimed invention cannot be considered to involve an inventive step when the document is combined with one or more other such documents, such combination being obvious to a person skilled in the art.</p> <p>¹⁵ document member of the same patent family</p>		
IV. CERTIFICATION		
Date of the Actual Completion of the International Search	Date of Mailing of this International Search Report	
14 FEBRUARY 1992	16 MAR 1992	
International Searching Authority	Signature of Authorized Officer	
ISA/US	 DEBRA S. BUNTINGHAM	