

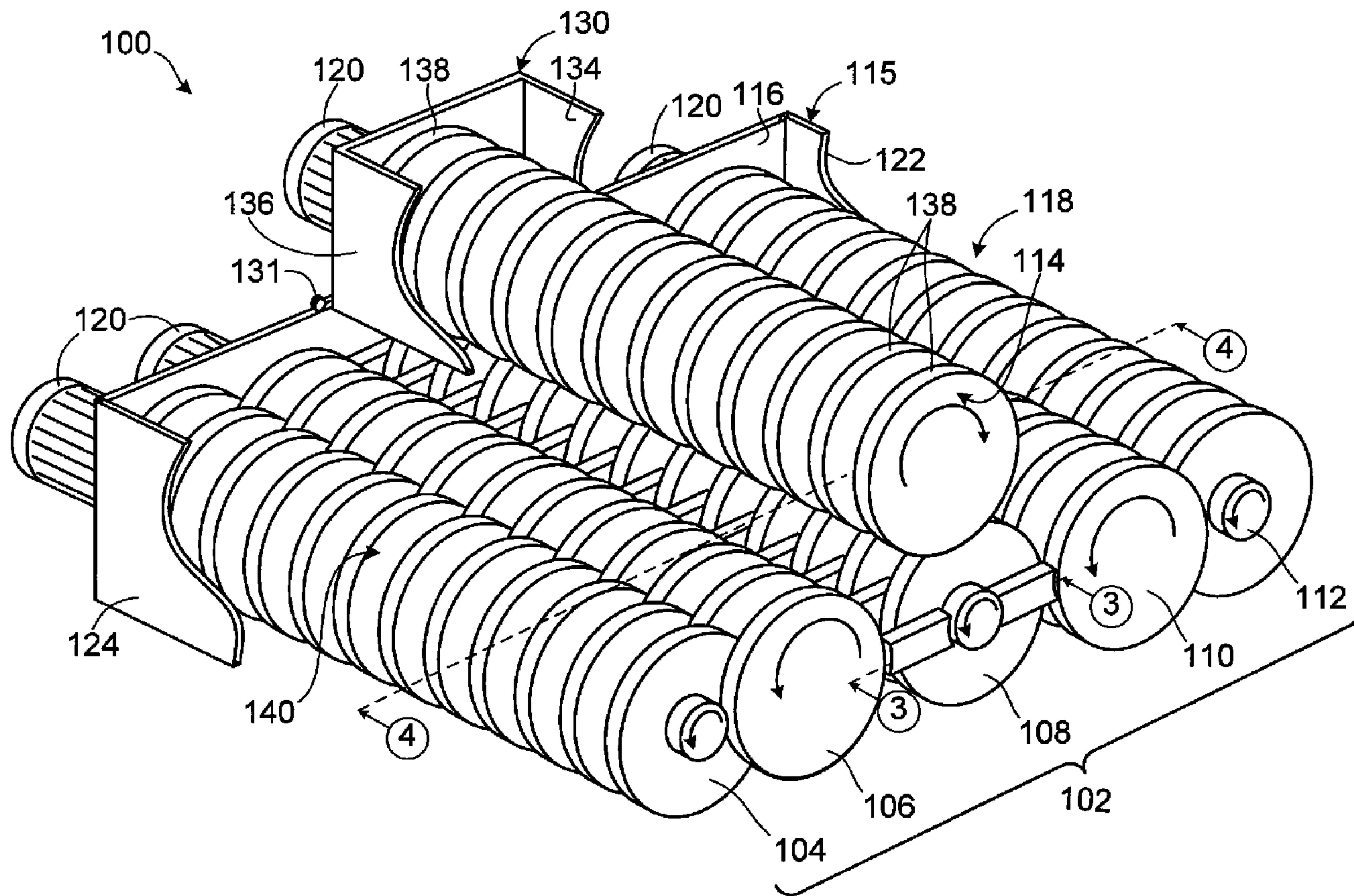

(22) Date de dépôt/Filing Date: 2009/09/18
 (41) Mise à la disp. pub./Open to Public Insp.: 2010/03/18
 (45) Date de délivrance/Issue Date: 2013/10/22
 (30) Priorités/Priorities: 2008/09/18 (US61/098209);
 2008/10/07 (CA2640514)

(51) Cl.Int./Int.Cl. *B07B 1/14* (2006.01),
B02C 23/08 (2006.01), *B02C 4/02* (2006.01)
 (72) Inventeur/Inventor:
 BRUGGENCATE, KYLE ALAN, CA
 (73) Propriétaire/Owner:
 SUNCOR ENERGY INC., CA
 (74) Agent: SMART & BIGGAR

(54) Titre : METHODE ET APPAREIL POUR LE TRAITEMENT DE L'ALIMENTATION DE MINERAL
 (54) Title: METHOD AND APPARATUS FOR PROCESSING AN ORE FEED



(57) Abrégé/Abstract:

A sizing roller screen apparatus and method for processing an ore feed received at an inlet is disclosed. The ore feed includes sized ore portions and oversize ore portions. The apparatus includes a roller screen having a plurality of adjacent screening rollers



(57) **Abrégé(suite)/Abstract(continued):**

supported to provide interstices therebetween for permitting passage of the sized ore portions between the adjacent screening rollers, the adjacent screening rollers being operably configured to rotate to cause a first sized ore portion to pass through the interstices while the ore feed is being transported along the roller screen. The apparatus also includes a sizing roller disposed generally above an opposing one of the plurality of adjacent screening rollers, the sizing roller being operably configured to rotate to fragment at least some of the oversize ore portions passing between the sizing roller and the opposing screening roller to produce a second sized ore portion, the second sized ore portion being sized for passage between the interstices.

ABSTRACT

A sizing roller screen apparatus and method for processing an ore feed received at an inlet is disclosed. The ore feed includes sized ore portions and
5 oversize ore portions. The apparatus includes a roller screen having a plurality of adjacent screening rollers supported to provide interstices therebetween for permitting passage of the sized ore portions between the adjacent screening rollers, the adjacent screening rollers being operably configured to rotate to cause a first sized ore portion to pass through the
10 interstices while the ore feed is being transported along the roller screen. The apparatus also includes a sizing roller disposed generally above an opposing one of the plurality of adjacent screening rollers, the sizing roller being operably configured to rotate to fragment at least some of the oversize ore portions passing between the sizing roller and the opposing screening roller to
15 produce a second sized ore portion, the second sized ore portion being sized for passage between the interstices.

METHOD AND APPARATUS FOR PROCESSING AN ORE FEED

BACKGROUND OF THE INVENTION

1. Field of Invention

5 This invention relates generally to processing of ore and more particularly to processing excavated ore including sized ore portions and oversize ore portions.

2. Description of Related Art

10 Surface mining operations are generally employed to excavate an ore deposit that is found near the surface. Such ore deposits are usually covered by an overburden of rock, soil, and/or plant matter, which may be removed prior to commencing mining operations. The remaining ore deposit may then be excavated and transported to a plant for processing to remove commercially
15 useful products. The ore deposit may comprise an oil sand deposit from which hydrocarbon products may be extracted, for example.

In general, excavated ore includes sized ore portions having a size suitable for processing and oversize ore portions that are too large for processing.

20 The oversize ore portions may be discarded and/or crushed to produce sized ore.

In the example of an oil sand ore deposit, such as the Northern Alberta oil sands, the ore deposit comprises about **70** to about **90** percent by weight of
25 mineral solids including sand and clay, about **1** to about **10** percent by weight of water, and a bitumen or oil film. The bitumen may be present in amounts ranging from a trace amount up to as much as **20** percent by weight. Due to the highly viscous nature of bitumen, when excavated some of the ore may remain as clumps of oversize ore that requires sizing to produce a sized ore
30 feed suitable for processing. Due to the northerly geographic location of

many oil sands deposits, the ore may also be frozen making sizing of the ore more difficult. Such processing may involve adding water to the ore feed to produce an oil sand slurry, for example.

5 SUMMARY OF THE INVENTION

10 In accordance with one aspect of the invention there is provided a sizing roller screen apparatus for processing an ore feed received at an inlet, the ore feed including sized ore portions and oversize ore portions. The apparatus includes a roller screen having a plurality of adjacent screening rollers supported to provide interstices therebetween for permitting passage of the sized ore portions between the adjacent screening rollers, the adjacent screening rollers being operably configured to rotate to cause a first sized ore portion to pass through the interstices while the ore feed is being transported along the roller screen. The apparatus also includes a sizing roller disposed
15 generally above an opposing one of the plurality of adjacent screening rollers, the sizing roller being operably configured to rotate to fragment at least some of the oversize ore portions passing between the sizing roller and the opposing screening roller to produce a second sized ore portion, the second sized ore portion being sized for passage between the interstices.

20

At least some of the screening rollers may include a plurality of spaced apart generally circular plates supported on a shaft, the plates arranged along the shaft to intermesh with spaced apart plates of an adjacent screening roller to provide the interstices.

25

The sizing roller may include a plurality of generally circular spaced apart plates supported on a shaft, the plates arranged along the shaft to intermesh with spaced apart plates of the opposing screening roller.

30

The opposing screening roller may be spaced apart from the adjacent screening rollers and the roller screen may further include a plurality of static

plates extending between the opposing screening roller and an adjacent screening roller and intermeshing therewith, the static plates being sufficiently spaced apart to permit the sized ore portions to pass between the static plates.

5

The sizing roller may define an outer working surface that is sufficiently spaced apart from an outer working surface of the opposing screening roller to permit at least some of the oversized ore portions to be fragmented to produce the second sized ore portion.

10

The outer working surface of the sizing roller may include a wear resistant overlay for reducing abrasion of the sizing roller by the ore feed.

15

The outer working surface of the sizing roller may be spaced apart from the outer working surface of the opposing screening roller in proportion to a spacing between outer working surfaces of the plurality of adjacent screening rollers.

20

The outer working surface of the sizing roller may be spaced apart from the outer working surface of the opposing screening roller by about **50** mm to about **60** mm.

25

The outer working surface of the sizing roller may include first engagement provisions for engaging the oversized ore portion and forcing the oversized ore portion against the outer working surface of the one of the plurality of adjacent screening rollers to cause the oversized ore portion to be fragmented to produce the second sized ore portion.

30

The outer working surface of the opposing screening roller may include second engagement provisions for engaging the oversized ore portion and forcing the oversized ore portion against the outer working surface of the

sizing roller to cause the oversized ore portion to be fragmented to produce the second sized ore portion.

5 The first engagement provisions and the second engagement provisions may include respective first and second engagement features that intermesh with each other to fragment the oversized ore portion.

10 The sizing roller may include a compliant mounting operably configured to permit the sizing roller to be displaced away from the opposing screening roller when oversize ore that resists fragmentation is passed between the sizing roller and the opposing screening roller.

15 The adjacent screening rollers may be supported in a first frame and the sizing roller may be mounted in a second frame disposed above the first frame, and the compliant mounting may include a pivot between the first and second frames, the pivot being operably configured to permit the second frame to displace away from the opposing screening roller.

20 The roller screen may include a discharge outlet located distally along the roller screen from the inlet, the outlet being operably configured to discharge the oversize ore that resists fragmentation.

25 The apparatus may include a comminutor located to receive the oversize ore from the outlet, the comminutor being operably configured to fragment the oversize ore to provide a third sized ore portion.

30 The apparatus may include a variable speed drive coupled to each of the adjacent screening rollers and the sizing roller, the variable speed drive being operable to permit configuration of respective rotational speeds of each of the rollers for processing the ore feed.

The ore feed may include a bitumen portion, and the apparatus may further include at least one nozzle disposed to spray heated water onto the ore feed to cause the bitumen portion to become less viscous thereby aiding in the processing of the ore feed.

5

The at least one nozzle may include a plurality of nozzles located along an entire length of the roller screen and operably configured to spray heated water onto the ore feed as the ore feed moves along the roller screen.

10

The roller screen may be disposed above a slurry vessel operable to produce a bitumen ore slurry of the sized ore that passes through the roller screen.

The opposing screening roller may include a generally centrally located one of the plurality of adjacent screening rollers.

15

The plurality of adjacent screening rollers may include first, second, third, fourth and fifth adjacent screening rollers, and the opposing screening roller may be the third adjacent roller.

20

In accordance with another aspect of the invention there is provided a method for processing an ore feed, the ore feed including sized ore portions and oversize ore portions. The method involves receiving the ore feed at an inlet of a roller screen having a plurality of adjacent screening rollers supported to provide interstices therebetween for permitting passage of the sized ore portions between the adjacent screening rollers. The method also involves causing the adjacent screening rollers to rotate to cause a first sized ore portion to pass through the interstices while the ore feed is being transported along the roller screen to a sizing roller disposed generally above an opposing one of the plurality of adjacent screening rollers. The method further involves causing the sizing roller to rotate to fragment at least some of the oversize ore portions passing between the sizing roller and the opposing screening roller to

25
30

produce a second sized ore portion, the second sized ore portion being sized for passage between the interstices.

Receiving the ore feed may involve receiving an ore feed including bitumen.

5

Receiving the ore feed may involve receiving an ore feed at a roller screen disposed above a slurry vessel operable to produce a bitumen ore slurry of the sized ore that passes through the roller screen.

10

Causing the sizing roller to rotate to fragment at least some of the oversize ore portions may involve causing first engagement features on the sizing roller to engage the oversized ore portion and force the oversized ore portion against an outer working surface of the opposing screening roller.

15

Causing the sizing roller to rotate to fragment at least some of the oversize ore portions may involve causing second engagement features on the outer working surface of the opposing screening roller to engage the oversized ore portion between the first and second engagement features to cause the oversized ore portion to be fragmented between the sizing roller and the

20

The method may involve discharging the oversize ore that resists fragmentation at an oversize discharge outlet located distally from the inlet along the roller screen.

25

The method may involve receiving the oversize ore from the outlet at a comminutor operably configured to fragment the oversized ore portions to provide a third sized ore portion.

-7-

The method may involve configuring a variable speed drive coupled to each of the adjacent screening rollers and the sizing roller to adjust respective rotational speeds of each of the rollers for processing the ore feed.

5 The method may involve causing at least one nozzles to spray heated water onto the ore feed to cause a bitumen portion of the ore feed to become less viscous thereby aiding in the processing of the ore feed.

10 Causing the at least one nozzle to spray heated water onto the ore feed may involve causing a plurality of nozzles to spray heated water onto the ore feed along an entire length of the roller screen.

15 Other aspects and features of the present invention will become apparent to those ordinarily skilled in the art upon review of the following description of specific embodiments of the invention in conjunction with the accompanying figures.

BRIEF DESCRIPTION OF THE DRAWINGS

In drawings which illustrate embodiments of the invention,

20

Figure 1 is a partially cut away perspective view of an apparatus for processing an ore feed in accordance with a first embodiment of the invention;

25

Figure 2 is a plan view of the apparatus shown in Figure 1;

Figure 3 is a cross sectional view of a circular plate taken along the line 3 - 3 in Figure 1;

30

Figure 4 is a cross sectional view of a pair of opposing circular plates taken along the line 4 - 4 in Figure 1;

Figure 5 is a side schematic view of a slurry apparatus incorporating the apparatus shown in Figure 1; and

5 Figure 6 is a schematic view of an alternative roller configuration for the apparatus shown in Figure 1.

DETAILED DESCRIPTION

10 Referring to Figure 1, a sizing roller screen apparatus for processing an ore feed according to a first embodiment of the invention is shown generally at **100**. The apparatus **100** includes a roller screen **102** having a plurality of adjacent screening rollers **104**, **106**, **108**, **110**, and **112**.

15 The apparatus **100** has an inlet **118** for receiving the ore feed. In the embodiment shown the ore feed is received at the roller **112**. The ore feed may be excavated ore from a ore deposit, such as a bitumen ore deposit, and generally includes sized ore portions and oversize ore portions. The excavated ore may be pre-sized proximate the mine face and transported to the apparatus **100** along a conveyor belt. The pre-sized ore may also have
20 metal or other detritus removed that could cause damage to the apparatus **100**. In the example of bitumen ore, the pre-sized ore may include sand and other fine constituents, rocks, and chunks of agglomerated bitumen, sand and rock in sizes less than about **400** mm. In general it is desired to process the ore to produce ore for further processing that is sized to be no larger than a
25 certain maximum size (for example, a **50** mm nominal size).

The adjacent screening rollers **104** – **112** are supported by a first sidewall **116** to provide interstices therebetween. The screening rollers **104** – **112** of the roller screen **102** are shown in plan view in Figure 2. Referring to Figure 2,
30 the interstices between the adjacent rollers **104** to **112** of the roller screen **102** are shown at **150**. In general the size of the interstices **150** is selected to

pass sized ore portions of a nominal passing size (e.g. about **50** mm to about **60** mm , as in the example of the bitumen ore above).

Referring back to Figure 1, the apparatus **100** also includes a sizing roller **114**
5 disposed generally above an opposing one of the plurality of adjacent rollers
in the roller screen **102** (in this case above the roller **108**, which in the
embodiment shown is centrally located with respect to the screening rollers
104 – 112). In other embodiments, the sizing roller **114** may be located above
one of the other adjacent screening rollers **104, 106, 110, or 112**.

10 The apparatus **100** is operably configured to cause the plurality of adjacent
screening rollers **104 – 112** to rotate to cause a first sized ore portion to pass
through the interstices **150** while the ore feed is transported along the roller
screen toward the sizing roller **114**. In this embodiment, the apparatus **100**
15 includes a motor **120** coupled to each of the respective adjacent screening
rollers **104 – 112** and the sizing roller **114**, for imparting a rotational drive to
the rollers in the direction indicated by the arrows in Figure 1. The apparatus
100 generally receives an ore feed at the inlet **118** and transports the ore feed
along the adjacent screening rollers **112, 110, 108, 106, and 104**, to a
20 discharge outlet **140**, where unbreakable oversize ore portions are discharged
or further processed (as disclosed later herein).

The sizing roller **114** is coupled to the motor **120**, which provides a driving
force for causing the roller to rotate to fragment at least some of the oversize
25 ore portions between the sizing roller and the roller **108** to produce a second
sized ore portion. The second sized ore portion is sized for passage between
the interstices **150**.

In the embodiment shown, the rollers **104 – 112** are supported in a frame **115**
30 having a first sidewall **116**, a first end wall **122** at the inlet **118**, and a second
end wall **124** proximate the roller **104**. The first and second end walls **122**

-10-

and **124** are shown partially cut away in Figure 1. The first and second end walls **122** and **124** are shown in top view in Figure 2, in which the frame **115** and a second sidewall **152** are also shown.

5 In the embodiment shown in Figure 1 and Figure 2, the screening rollers **104** – **112** each include a plurality of spaced apart generally circular plates **154** supported on a shaft **156**. The plates **154** define respective working surfaces of each of the rollers **104** – **112**. The roller **104** is shown in cross-sectional view in Figure 3. Referring to Figure 3, each of the generally circular plates
10 **154** includes a body portion **180** supported on the shaft **156**. The body portion **180** further includes a first wear resistant overlay **182**. In the embodiment shown, the shaft **156** includes a second wear resistant overlay **184**. The first and second wear resistant overlays **182** and **184** together define a working surface of the respective rollers **104** – **112**.

15 In the embodiment shown in Figure 3, the overlays **182** and **184** each have scalloped engagement features **186** to facilitate engagement of portions of the ore feed, but in other embodiments the overlays may have a variety of otherwise shaped engagement features. The engagement features act as
20 means for engaging the ore. The body portion **180** may comprise mild steel, while the wear resistant overlays **182** and **184** may comprise hardened steel or cast white iron, for example. The wear resistant overlays **182** and **184** are selected to resist abrasion of the working surfaces by the ore feed. The shaft **156** is coupled to the motor **120**, either directly or through a gearbox, for
25 driving the roller **104** (or rollers **106** – **112**).

Referring back to Figure 2, the first and second end walls **122** and **124** may each additionally include a plurality of static plates **158**, extending between the circular plates **154** and intermeshing therewith. In the embodiment shown
30 in Figure 1 and Figure 2, the rollers **106** and **110** are spaced apart from the roller **108** and a further plurality of intermeshing static plates **126** and **128**

extend between the circular plates **154** of the adjacent screening rollers **106** and **108**, and **106** and **110**, and therewith. The static plates permit the sized ore to pass while preventing oversize ore portions from passing between the static plates.

5

Referring back to Figure 1, the sizing roller **114** is supported by a frame **130** having a third sidewall **132**, a fourth sidewall (not shown) and end walls **134** and **136**. In the embodiment shown the sizing roller **114** is compliantly mounted to permit the roller to displace upwardly to allow passage of unbreakable oversize ore portions, thereby avoiding damage to the roller. In the embodiment shown, the frame **130** includes a pivot wheel **131** for pivotably mounting the frame **130** on the frame **115**. Similar pivot wheels are also included on the fourth sidewall (not shown). The pivot wheel **131** permits the frame **130** and sizing roller **114** to be pivoted upwardly to allow an unbreakable oversize ore portion to pass through between the rollers **114** and **108**. Alternatively, the sizing roller **114** may be compliantly mounted on a sprung frame that urges the sizing roller **114** toward the roller **108** and provides a pre-determined compression force and permits movement away from the roller **108** when such unbreakable oversize ore portions pass between the rollers.

10

15

20

The sizing roller **114** also includes a plurality of spaced apart generally circular plates **138** defining a working surface. One of the circular plates **138** is shown in cross-sectional detail in Figure 4. The intermeshing circular plate **154** of the roller **108** is also shown in Figure 4. Referring to Figure 4, the circular plate **138** includes a body portion **190** supported on a shaft **196**. The body portion **190** has a third wear resistant overlay **192**. In this embodiment the third wear resistant overlay **192** further includes a plurality of hooked engagement features **194** that act as means for engaging the oversize ore portions and fragmenting the oversize portions against the working surfaces of the plates **154**. The shaft **196** includes a fourth wear resistant overlay **198**.

25

30

In this embodiment, the third and fourth wear resistant overlays **192** and **198** make up the outer working surface of the sizing roller **114**. Fragmentation of the ore generally occurs between the wear resistant overlays **192**, **198**, **182** and **184** of the respective interleaved circular plates.

5

In certain embodiments, the outer working surface of the sizing roller **114** may be spaced apart from the outer working surface of the opposing screening roller **108** in proportion to a spacing between outer working surfaces of the plurality of adjacent screening rollers. For example, the outer working surface of the sizing roller **114** may be spaced apart from the outer working surface of the opposing screening roller **108** by about **50** mm to about **60** mm.

10

Referring to Figure 5, in one embodiment the apparatus **100** is used to size ore for producing a slurry in a slurry apparatus shown generally at **200**. The slurry apparatus **200** includes a slurry vessel **202**. The slurry vessel **202** has an upper opening **204** and is also provided with a solvent inlet **203**, which is in communication with a solvent source (not shown), and an outlet **205**. The apparatus **100** is located above the opening **204** of the slurry vessel **202**.

15

20

The inlet **118** of the sizing roller screen apparatus **100** is in communication with a slope sheet **206** for receiving an ore feed **208** from a transfer conveyor **210**. In this embodiment a batter board **212** is also provided at the inlet **118** to deflect ore portions and spread the ore laterally across the inlet to provide a generally uniform ore feed across the roller **112**. The batter board **212** may be curved or otherwise shaped to deflect some ore portions to either side of the inlet **118** to produce a uniform ore feed. The apparatus **100** also includes nozzles **214**, **216**, **218**, and **219**, which are disposed to spray solvent on the ore feed. The nozzles **214**, **216**, and **218**, are in communication with a fluid supply conduit for receiving solvent from a pressurized solvent source (not shown).

25

30

-13-

In the embodiment shown in Figure 5, the slurry apparatus **200** also includes a comminutor **230** disposed to receive oversized ore portions from the discharge outlet **140**. The comminutor **230** includes a pair of rollers **232**, spaced apart to provide a gap **236** between the rollers. The gap **236** is selected to fragment oversize ore portions to produce sized ore portions. In general the rollers **232** and **234** are of heavier and more robust construction and provide greater fragmenting force than the sizing roller **114** and the opposing screening roller **108**.

5 The operation of the apparatus **200** to produce a slurry of a bitumen ore feed is described with reference to Figure 5. However, the apparatus **100** may also be used for sizing other ore feeds, and the resulting sized ore may be used as a feed for producing a slurry or for other processing operations.

10 The ore feed **208** is received from the transfer conveyor **210** and is discharged onto the slope sheet **206**. The nozzle **219** is located to spray solvent onto the ore feed **208** to begin breaking down oversize portions. For a bitumen ore feed, the solvent provided through the conduit **220** may be heated water, which causes the bitumen portion to become less viscous thereby dissociating or partly dissolving bitumen clumps to aid in processing. Alternatively, the conduit **220** may be used to supply a solvent other than water to the nozzles **214**, **216**, **218**, and **219**. Advantageously, applying heated water to the ore feed **208** along the slope sheet **212** allows more time for the heated water combine with and to begin dissolving the bitumen clumps.

Ore portions of the ore feed **208** that strike the batter board **212** may be sidewardly directed to provide an ore feed at the inlet **118** that is uniformly distributed across the roller **112**.

30

-14-

The nozzles **218** and **216** are operated to spray heated water at the ore feed **208** while in transit over the rollers **112** and **110**. The ore feed **208** may include portions already of a nominal size and/or the action of the heated water may cause clumps to break down into nominally sized ore portions, which are able to pass through the interstices **150** (shown in Figure **2**) to produce a first sized ore portion **222**. Referring back to Figure **2**, the configuration of the screening rollers **104** – **112**, static plates **126** and **128**, and the first and second end walls **122** and **124** provides a general uniform interstitial spacing over the area of the apparatus **100**. The uniform interstitial spacing allows ore portions of a desired nominal size to pass through the screen into the slurry vessel **202**. The heated water supplied through the nozzles **216** and **218** also helps prevent blockage of the apparatus **100** due to buildup of bitumen in the interstices **150**.

Oversize ore portions are unable to pass through the interstices **150** and remain on top of the roller screen and are transported along the adjacent rollers **112**, **110**, and to roller **108** by the rotation of the rollers in the direction indicated by the arrows in Figure **5**. The engagement features on the rollers assist in transporting the ore along the roller screen **102** away from the inlet **118** and may also assist in breaking up clumps of ore in transit. While the oversize ore portions are being transported, the action of the hot water provided by the nozzles **216** and **218** and the tumbling action of the rollers **112**, **110**, and **108** may cause clumps to break off the oversize ore portions, thus reducing the size of the oversize portions and producing further sized ore portions that are able to pass through the interstices **150**.

Rotation of the roller **108** then causes oversize ore portions (and some sized ore portions that are incorporated in between oversize ore portions) to be fed between the sizing roller **114** and the opposing screening roller **108**. In the case of a bitumen ore feed, the oversize portions may include sand and/or rock clumped together by viscous bitumen that is fragmented by the action of

-15-

the sizing roller **114**. The configuration and spacing of the rollers **114** and **108** is selected to cause oversize ore portions to be broken up into ore portions of a desired nominal size, which are able to pass through the interstices between the adjacent screening rollers **106** and **108**, or **104** and **106** to produce second sized ore portion **240**. Referring back to Figure 4, in the embodiment shown the hooked engagement features **194** operate to engage oversize ore portions and force the engaged ore against the surface of the roller **108**, thereby sizing the ore feed.

Referring again to Figure 5, the nozzle **214** sprays hot water on the ore that passes between the rollers **114** and **108** to further aid in breaking down the ore. In one embodiment the nozzles **214**, **216** and **218** are arranged along an entire length of the roller screen **102** such that heated water or solvent is sprayed onto the ore feed **208** as the ore feed moves along the roller screen **102** from the inlet **118** to the outlet **140**, which provides a feed to the comminutor **230**.

Advantageously, the provision of the sizing roller **114** provides more active breaking up of oversize or portions in the ore feed **208** than is provided by the rolling or tumbling action of the adjacent rollers **104** – **112**, thereby sizing a greater portion of the ore feed and reducing discharge of oversize ore portions from the roller **104**.

The ore feed **208** may also include unbreakable oversize ore portions such as granite, for example. Accordingly, the frame **130** is configured to pivot about the pivot wheel **131**, as described earlier, to permit passage of such ore portions. Unbreakable ore portions discharged from the sizing roller screen are received at the comminutor **230** and fragmented between the rollers **232** and **234** to produce a third sized ore portion **242**. Advantageously, providing the comminutor **230** for fragmenting the remaining ore portion obviates the need to deal with discarded ore, but in other embodiments the comminutor

230 may be omitted and unbreakable ore portions may be discarded or transported away from the slurry apparatus **200** by a conveyor (not shown).

In operation of the apparatus **100** shown in Figure **1**, each of the rollers **104 – 112** and **114** are independently driven by a motor **120** and the speed of each roller may be varied in response to the constitution of the ore feed **208** and to increase or reduce the working time at any of the interfaces between adjacent rollers. In other embodiments a single drive motor may be mechanically coupled to drive more than one of the rollers **104 – 112** and **114**.

The first, second and third sized ore portions **222**, **240** and **242**, together with the hot water added by the nozzles **214**, **216**, and **218** accumulate in the slurry vessel **202**. Further heated water may be added through the inlet **203** to produce a slurry **244**. The decreasing cross-sectional area of the slurry vessel **202** proximate the outlet **205** causes the slurry to be discharged through the outlet by forces of gravity. The outlet **205** may be in communication with a pump (not shown) for pumping the slurry along a pipeline (also not shown) for transport to apparatus where further processing of the slurry occurs. In general the addition of water is controlled to produce a slurry having a desired solids to water ratio for transport in a pipeline.

Referring to Figure **6**, an alternative arrangement of rollers for implementing the apparatus in accordance with another embodiment of the invention is shown in Figure **1** generally at **260**. In this embodiment, a plurality of screening rollers **262**, **264**, **270**, **266**, and **268** are disposed generally as shown in Figure **1**. A sizing roller **272** is disposed above the roller **270**, which acts as the opposing screening roller. The sizing roller **272** includes hooked engagement features **274** for engaging the oversize ore portions. In this embodiment, the opposing screening roller **270** also includes hooked engagement features **276** that intermesh with the engagement features **274** on the sizing roller **272**. Advantageously, the engagement features **274** and

-17-

276 cooperate to engage and fragment oversize ore portions to produce sized ore portions. Already sized ore portions in the ore feed received at the roller **262** may pass through interstices between the rollers **262** and **264**, or **264** and **270**, as described above.

5

The above embodiments have been described with reference to a roller screen having five adjacent rollers. However, depending on the ore feed and the desired nominal passing size, more or fewer rollers may be used to implement the apparatus.

10

While specific embodiments of the invention have been described and illustrated, such embodiments should be considered illustrative of the invention only and not as limiting the invention as construed in accordance with the accompanying claims.

THE EMBODIMENTS OF THE INVENTION IN WHICH AN EXCLUSIVE PROPERTY OR PRIVILEGE IS CLAIMED ARE DEFINED AS FOLLOWS:

- 5 1. A sizing roller screen apparatus for processing an ore feed received at an inlet, the ore feed including sized ore portions and oversize ore portions, the apparatus comprising:

10 a roller screen having a plurality of adjacent screening rollers supported to provide interstices therebetween for permitting passage of the sized ore portions between the adjacent screening rollers, the adjacent screening rollers being operably configured to rotate to cause a first sized ore portion to pass through the interstices while the ore feed is being transported along the roller screen; and

15 a sizing roller disposed generally above an opposing one of the plurality of adjacent screening rollers, the sizing roller being operably configured to rotate to fragment at least some of the oversize ore portions passing between the sizing roller and the opposing screening roller to produce a second sized ore portion, the second sized ore portion being sized for passage between
20 the interstices.

25 2. The apparatus of claim 1 wherein at least some of the screening rollers comprise a plurality of spaced apart generally circular plates supported on a shaft, the plates arranged along the shaft to intermesh with spaced apart plates of an adjacent screening roller to provide the interstices.

3. The apparatus of claim 2 wherein the sizing roller comprises a plurality of generally circular spaced apart plates supported on a shaft, the

plates arranged along the shaft to intermesh with spaced apart plates of the opposing screening roller.

- 5 4. The apparatus of claim 3 wherein the opposing screening roller is spaced apart from the adjacent screening rollers and wherein the roller screen further comprises a plurality of static plates extending between the opposing screening roller and an adjacent screening roller and intermeshing therewith, the static plates being sufficiently spaced apart to permit the sized ore portions to pass between the static plates.
- 10 5. The apparatus of any one of claims 1 to 4 wherein the sizing roller defines an outer working surface that is sufficiently spaced apart from an outer working surface of the opposing screening roller to permit at least some of the oversized ore portions to be fragmented to produce the second sized ore portion.
- 15 6. The apparatus of claim 5 wherein the outer working surface of the sizing roller comprises a wear resistant overlay for reducing abrasion of the sizing roller by the ore feed.
- 20 7. The apparatus of claim 5 wherein the outer working surface of the sizing roller is spaced apart from the outer working surface of the opposing screening roller in proportion to a spacing between outer working surfaces of the plurality of adjacent screening rollers.
8. The apparatus of claim 5 wherein the outer working surface of the sizing roller is spaced apart from the outer working surface of the opposing screening roller by about 50 mm to about 60 mm.
- 25 9. The apparatus of claim 5 wherein the outer working surface of the sizing roller comprises first engagement means for engaging the oversized ore portion and forcing the oversized ore portion against the

outer working surface of the one of the plurality of adjacent screening rollers to cause the oversized ore portion to be fragmented to produce the second sized ore portion.

- 5 **10.** The apparatus of claim **9** wherein the outer working surface of the opposing screening roller comprises second engagement means for engaging the oversized ore portion and forcing the oversized ore portion against the outer working surface of the sizing roller to cause the oversized ore portion to be fragmented to produce the second sized ore portion.
- 10 **11.** The apparatus of claim **10** wherein the first engagement means and the second engagement means comprise respective first and second engagement features that intermesh with each other to fragment the oversized ore portion.
- 15 **12.** The apparatus of any one of claims **1** to **11** wherein the sizing roller comprises a compliant mounting operably configured to permit the sizing roller to be displaced away from the opposing screening roller when oversize ore that resists fragmentation is passed between the sizing roller and the opposing screening roller.
- 20 **13.** The apparatus of claim **12** wherein the adjacent screening rollers are supported in a first frame and the sizing roller is mounted in a second frame disposed above the first frame, and wherein the compliant mounting comprises a pivot between the first and second frames, the pivot being operably configured to permit the second frame to displace away from the opposing screening roller.
- 25 **14.** The apparatus of any one of claims **1** to **13** wherein the roller screen comprises a discharge outlet located distally along the roller screen

from the inlet, the outlet being operably configured to discharge the oversize ore that resists fragmentation.

- 5
- 15.** The apparatus of claim **14** further comprising a comminutor located to receive the oversize ore from the outlet, the comminutor being operably configured to fragment the oversize ore to provide a third sized ore portion.
- 10
- 16.** The apparatus of any one of claims **1** to **15** further comprising a variable speed drive coupled to each of the adjacent screening rollers and the sizing roller, the variable speed drive being operable to permit configuration of respective rotational speeds of each of the rollers for processing the ore feed.
- 15
- 17.** The apparatus of any one of claims **1** to **16** wherein the ore feed comprises a bitumen portion, and further comprising at least one nozzle disposed to spray heated water onto the ore feed to cause the bitumen portion to become less viscous thereby aiding in the processing of the ore feed.
- 20
- 18.** The apparatus of claim **17** wherein the at least one nozzle comprises a plurality of nozzles located along an entire length of the roller screen and operably configured to spray heated water onto the ore feed as the ore feed moves along the roller screen.
- 19.** The apparatus of any one of claims **1** to **18** wherein the roller screen is disposed above a slurry vessel operable to produce a bitumen ore slurry of the sized ore that passes through the roller screen.
- 25
- 20.** The apparatus of any one of claims **1** to **19** wherein the opposing screening roller comprises a generally centrally located one of the plurality of adjacent screening rollers.

21. The apparatus of any one of claims 1 to 20 wherein the plurality of adjacent screening rollers comprise first, second, third, fourth and fifth adjacent screening rollers, and the opposing screening roller is the third adjacent roller.
- 5 22. A method for processing an ore feed, the ore feed including sized ore portions and oversize ore portions, the method comprising:
- 10 receiving the ore feed at an inlet of a roller screen having a plurality of adjacent screening rollers supported to provide interstices therebetween for permitting passage of the sized ore portions between the adjacent screening rollers;
- 15 causing the adjacent screening rollers to rotate to cause a first sized ore portion to pass through the interstices while the ore feed is being transported along the roller screen to a sizing roller disposed generally above an opposing one of the plurality of adjacent screening rollers; and
- 20 causing the sizing roller to rotate to fragment at least some of the oversize ore portions passing between the sizing roller and the opposing screening roller to produce a second sized ore portion, the second sized ore portion being sized for passage between the interstices.
23. The method of claim 22 wherein receiving the ore feed comprises receiving an ore feed comprising bitumen.
24. The method of claim 23 wherein receiving the ore feed comprises receiving an ore feed at a roller screen disposed above a slurry vessel operable to produce a bitumen ore slurry of the sized ore that passes through the roller screen.
- 25

- 5 **25.** The method of any one of claims **22** to **24** wherein causing the sizing roller to rotate to fragment at least some of the oversize ore portions comprises causing first engagement features on the sizing roller to engage the oversized ore portion and force the oversized ore portion against an outer working surface of the opposing screening roller.
- 10 **26.** The method of claim **25** wherein causing the sizing roller to rotate to fragment at least some of the oversize ore portions comprises causing second engagement features on the outer working surface of the opposing screening roller to engage the oversized ore portion between the first and second engagement features to cause the oversized ore portion to be fragmented between the sizing roller and the opposing screening roller.
- 15 **27.** The method of any one of claims **22** to **26** further comprising discharging the oversize ore that resists fragmentation at an oversize discharge outlet located distally from the inlet along the roller screen.
- 28.** The method of claim **27** further comprising receiving the oversize ore from the outlet at a comminutor operably configured to fragment the oversized ore portions to provide a third sized ore portion.
- 20 **29.** The method of claim **22** further comprising configuring a variable speed drive coupled to each of the adjacent screening rollers and the sizing roller to adjust respective rotational speeds of each of the rollers for processing the ore feed.
- 25 **30.** The method of claim **22** further comprising causing at least one nozzles to spray heated water onto the ore feed to cause a bitumen portion of the ore feed to become less viscous thereby aiding in the processing of the ore feed.

- 31.** The method of claim **30** wherein causing the at least one nozzle to spray heated water onto the ore feed comprises causing a plurality of nozzles to spray heated water onto the ore feed along an entire length of the roller screen.

5

10

+

1/5

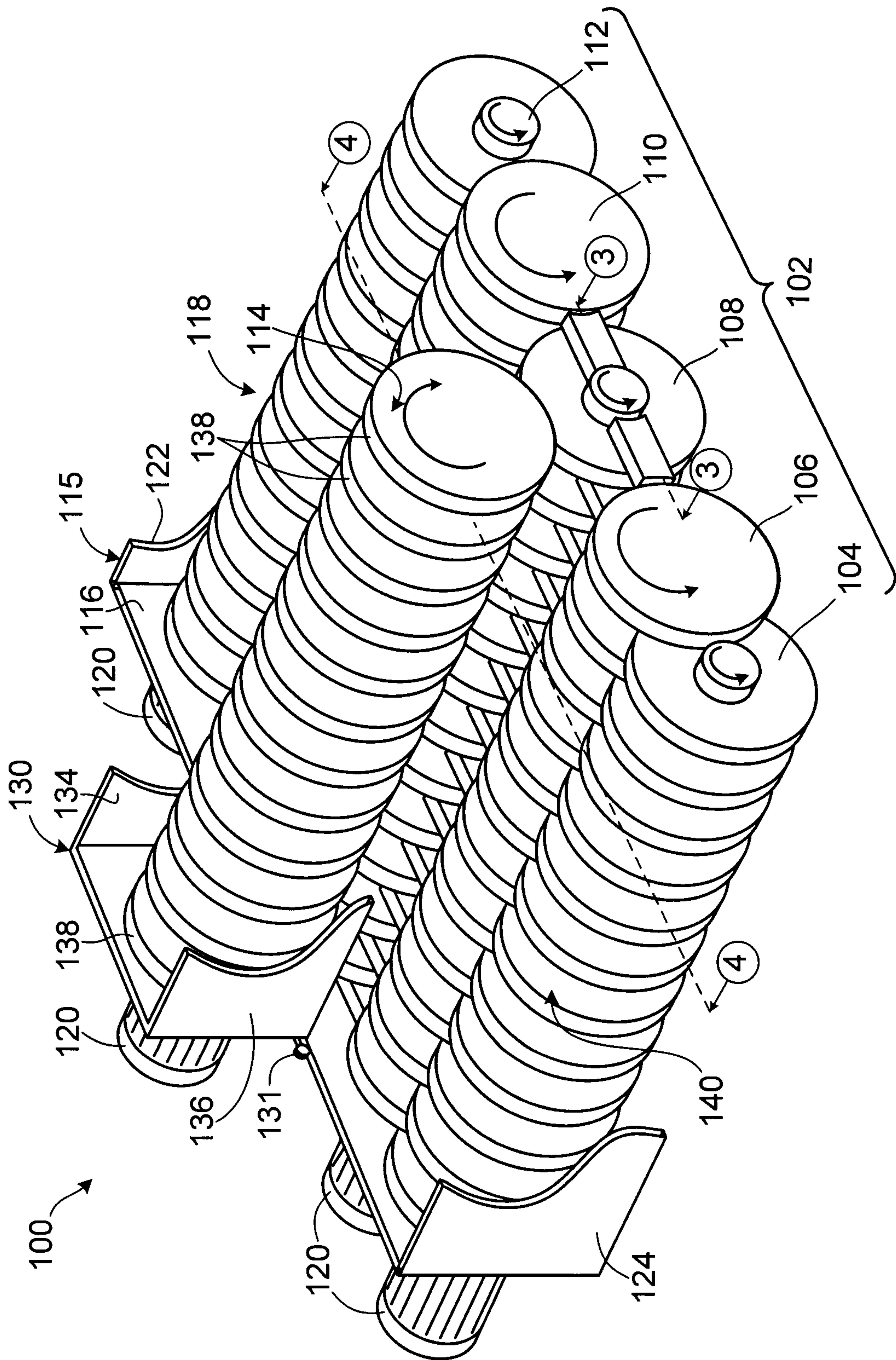

FIG. 1

+

2/5

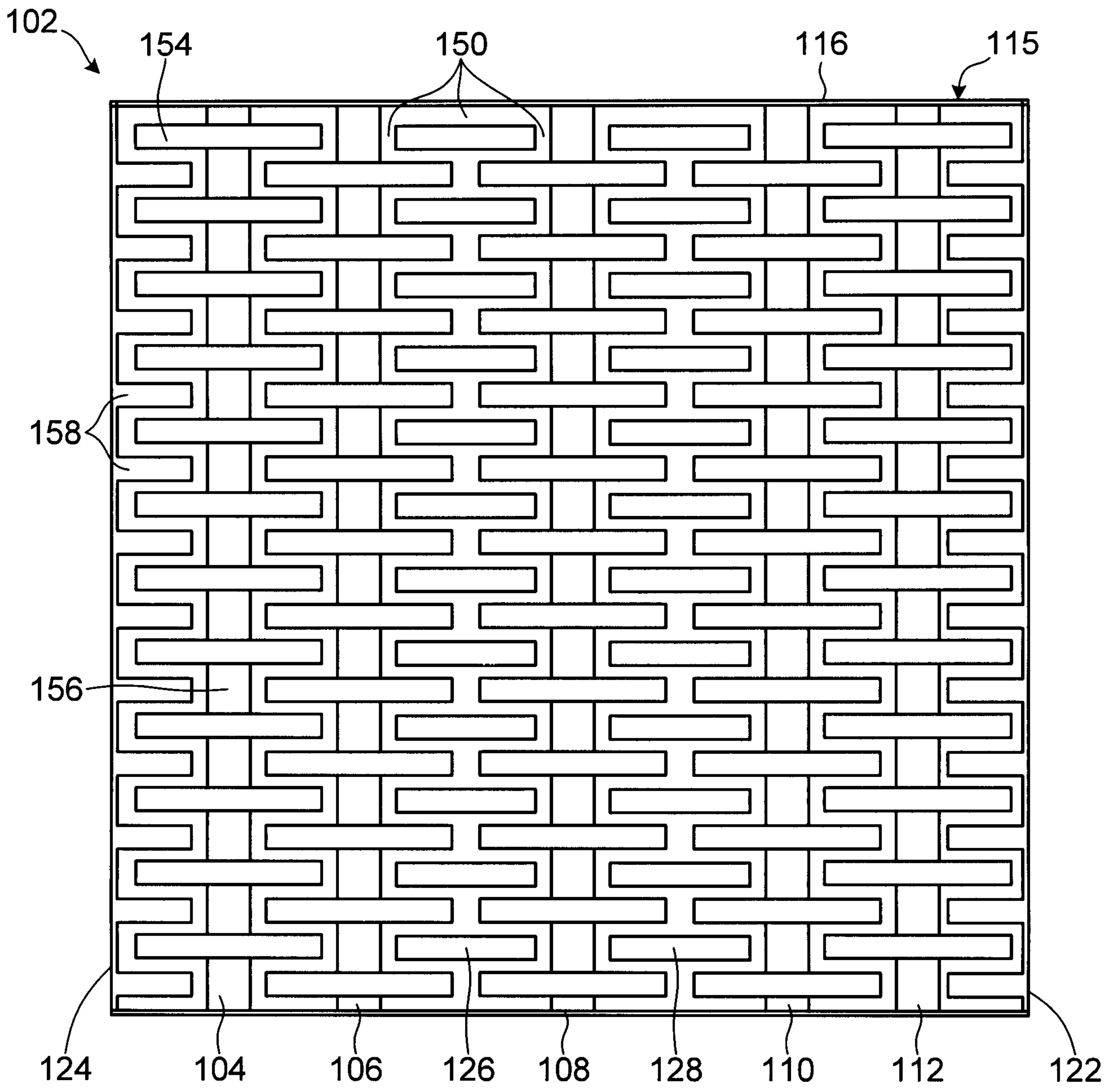

FIG. 2

+

3/5

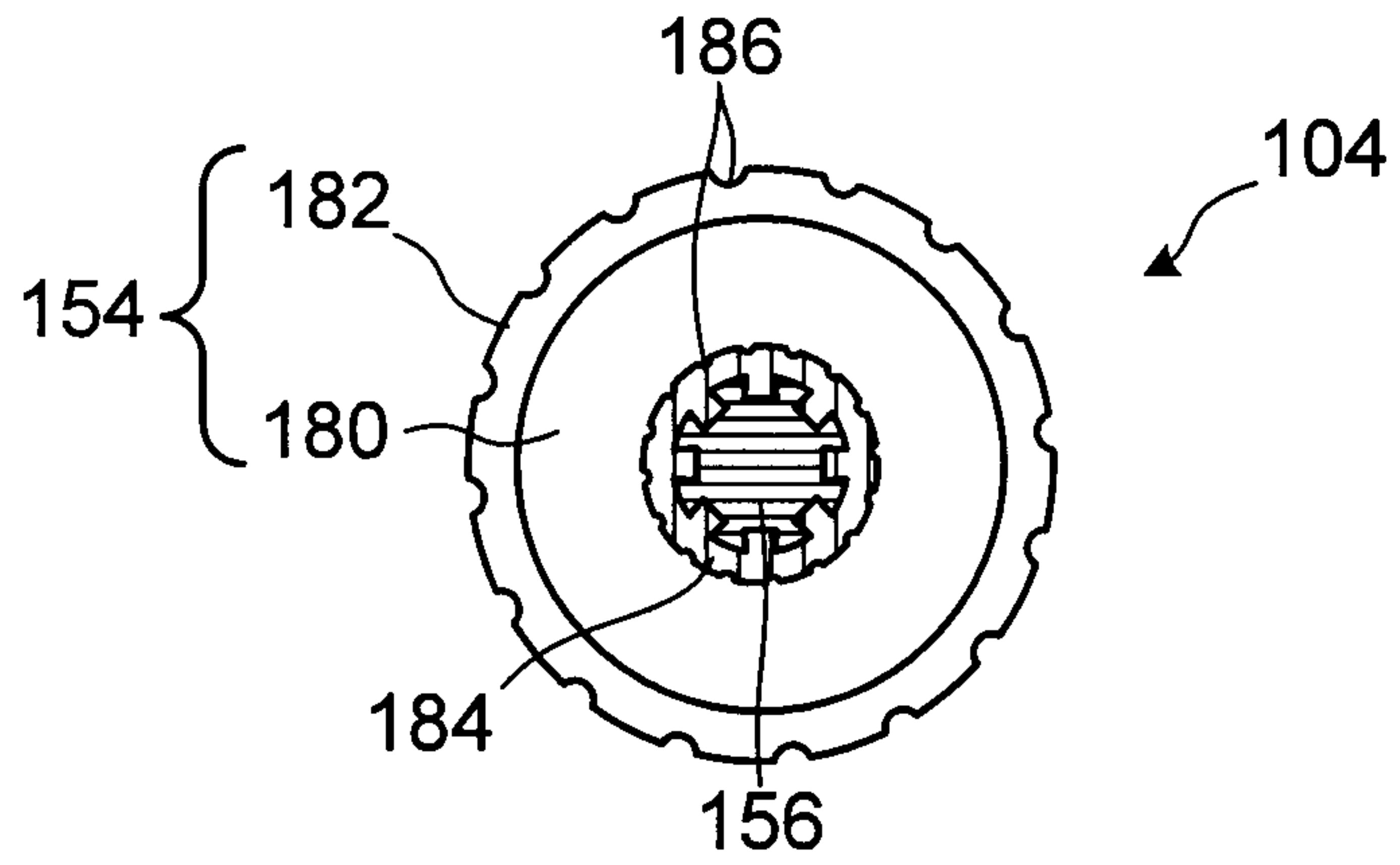

FIG. 3

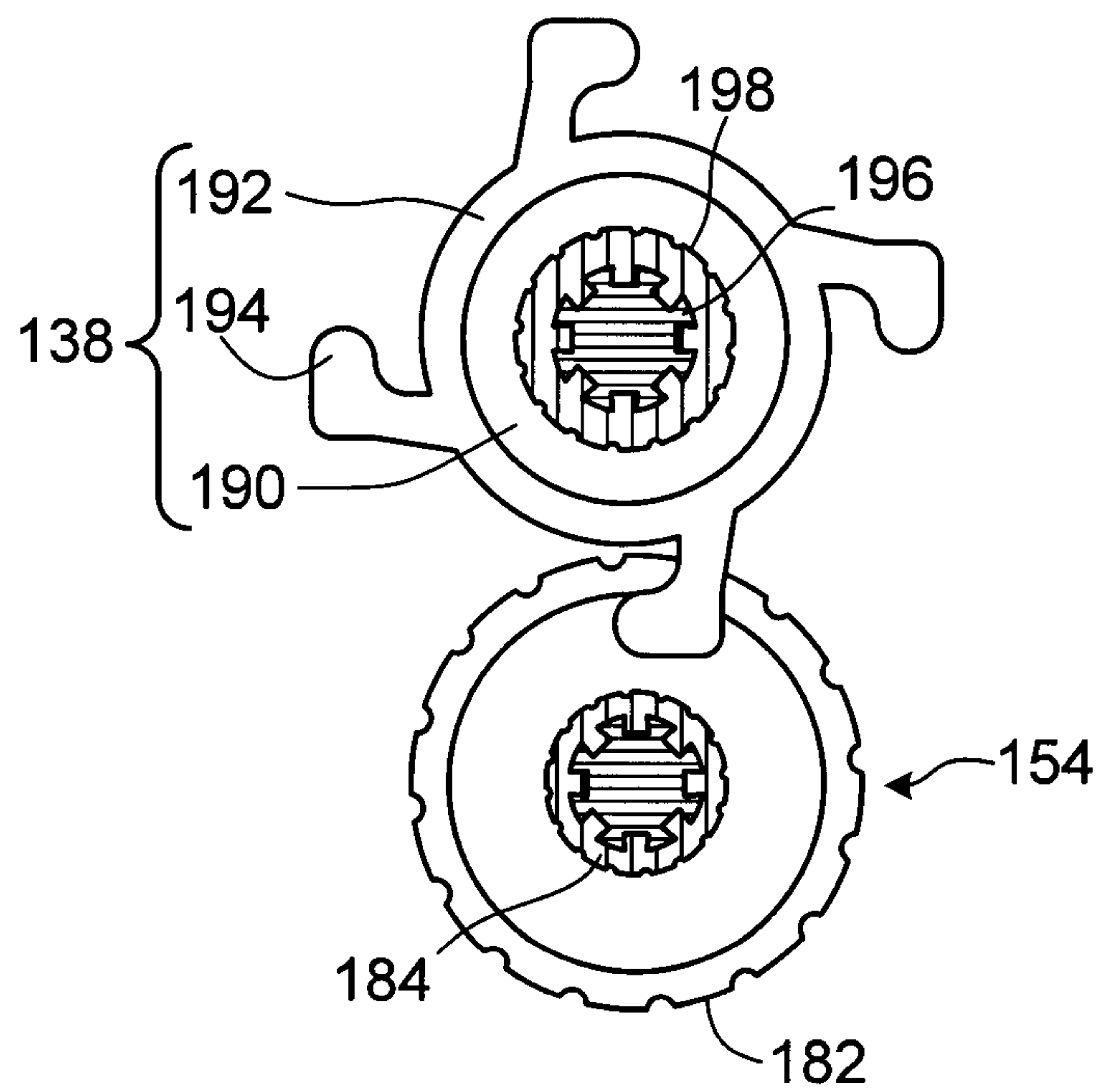

FIG. 4

+

5/5

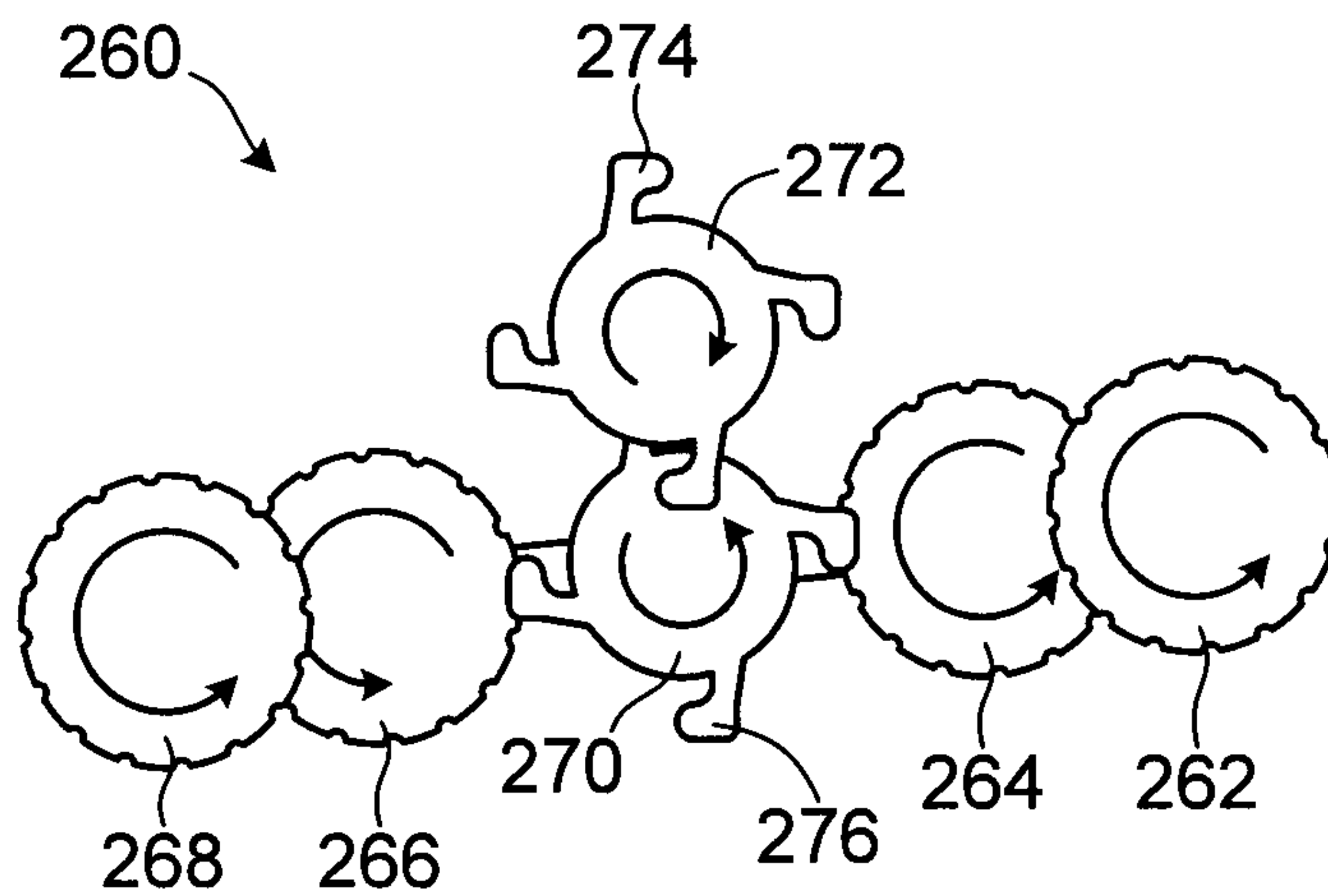

FIG. 6

