



- (51) International Patent Classification: **B65D 17/00** (2006.01)
- (21) International Application Number: PCT/US2015/042579
- (22) International Filing Date: 29 July 2015 (29.07.2015)
- (25) Filing Language: English
- (26) Publication Language: English
- (30) Priority Data:

62/030,736	30 July 2014 (30.07.2014)	US
62/152,577	24 April 2015 (24.04.2015)	US
- (71) Applicant: **BALL CORPORATION** [US/US]; 10 Longs Peak Drive, Broomfield, CO 80021 (US).
- (72) Inventors: **CHASTEEN, Howard, C.**; 9829 Otis Drive, Westminster, CO 80021 (US). **JACOBBER, Mark, A.**; 6027 Moore Street, Arvada, CO 80004 (US).
- (74) Agent: **KUGLER, Bruce, A.**; Sheridan Ross P.C., 1560 Broadway, Suite 1200, Denver, CO 80202 (US).
- (81) Designated States (unless otherwise indicated, for every kind of national protection available): AE, AG, AL, AM, AO, AT, AU, AZ, BA, BB, BG, BH, BN, BR, BW, BY, BZ, CA, CH, CL, CN, CO, CR, CU, CZ, DE, DK, DM, DO, DZ, EC, EE, EG, ES, FI, GB, GD, GE, GH, GM, GT, HN, HR, HU, ID, IL, IN, IR, IS, JP, KE, KG, KN, KP, KR, KZ, LA, LC, LK, LR, LS, LU, LY, MA, MD, ME, MG, MK, MN, MW, MX, MY, MZ, NA, NG, NI, NO, NZ, OM, PA, PE, PG, PH, PL, PT, QA, RO, RS, RU, RW, SA, SC, SD, SE, SG, SK, SL, SM, ST, SV, SY, TH, TJ, TM, TN, TR, TT, TZ, UA, UG, US, UZ, VC, VN, ZA, ZM, ZW.
- (84) Designated States (unless otherwise indicated, for every kind of regional protection available): ARIPO (BW, GH,

[Continued on next page]

(54) Title: VENTED CONTAINER END CLOSURE

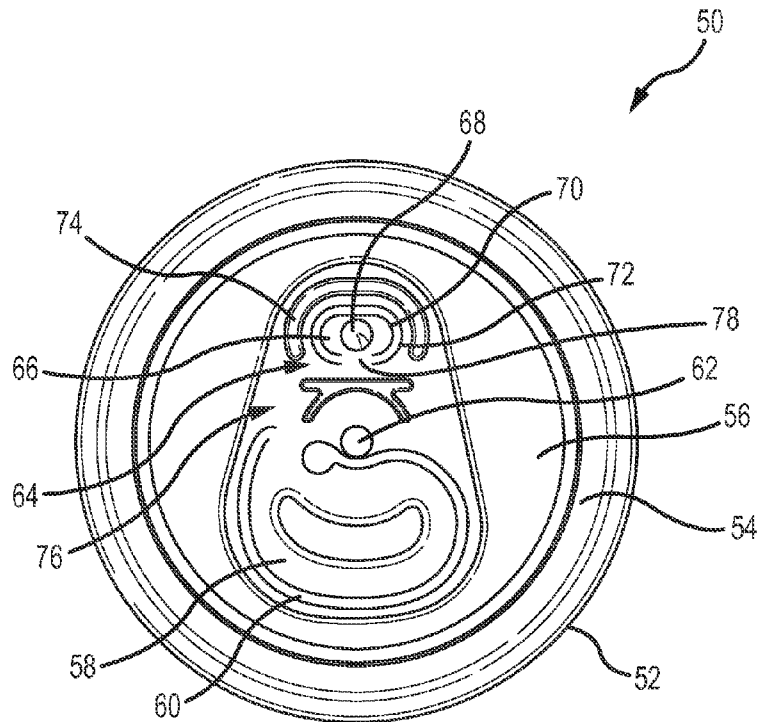

FIG. 14A

[Continued on next page]

WO 2016/018977 A1

GM, KE, LR, LS, MW, MZ, NA, RW, SD, SL, ST, SZ,
TZ, UG, ZM, ZW), Eurasian (AM, AZ, BY, KG, KZ, RU,
TJ, TM), European (AL, AT, BE, BG, CH, CY, CZ, DE,
DK, EE, ES, FI, FR, GB, GR, HR, HU, IE, IS, IT, LT,
LU, LV, MC, MK, MT, NL, NO, PL, PT, RO, RS, SE,

SI, SK, SM, TR), OAPI (BF, BJ, CF, CG, CI, CM, GA,
GN, GQ, GW, KM, ML, MR, NE, SN, TD, TG).

Published:

— with international search report (Art. 21(3))

(57) Abstract: A metallic container end closure is provided that generally comprises a dispensing opening and a vent opening. The vent opening improves pourability through the dispensing opening and provides an alternative option for consuming the contents of the container. The end closure may include features to ease opening of the vent opening, such as stiffeners and/or vent form features.

VENTED CONTAINER END CLOSURE

[0001] This Non-Provisional Application claims the benefit of and priority from U.S. Provisional Patent Application 62/030,736, filed July 30, 2014, and U.S. Provisional Patent Application 62/152,577, filed April 24, 2015, the entire disclosures of which are hereby incorporated by reference herein.

TECHNICAL FIELD

[0002] The present invention relates generally to metallic container end closures, and more particularly, to a vented metallic container end closure with a plurality of openings to provide enhanced flow and pourability.

BACKGROUND

[0003] Generally, the configuration of a container end closure affects the level to which end consumers, as well as bottlers, manufacturers, distributors, shippers, and retailers, are satisfied with a container. One factor believed to be of considerable importance to consumers is the pour characteristics of the container. In general, it is believed that consumers prefer to use containers capable of providing a relatively high and consistent pour rate. Additionally, it is believed consumers prefer containers that provide a smooth or substantially laminar pour, i.e. a pour which is not characterized by a series of surges or “glugging”.

[0004] Many container configurations exist to enhance flow through a container end closure aperture. For example, some containers utilize a single large hole to admit air for venting the dispensed liquid. Examples are provided in U.S. Patent Nos. 4,210,257; 5,007,554; 4,416,389; 4,148,410; 4,465,204; and 4,361,251; the disclosures of which are incorporated herein by reference in their entirety. Unfortunately, such larger openings tend to be associated with a higher rate of problems such as bursting, buckling, leakage, opening failures and the like, particularly when the contents are pressurized with carbonated beverages such as beer or soda. Additionally, in configurations of large openings coupled with relatively small hinge regions, container leakage and/or separation of the panel and/or other components can be a problem upon opening. In some instances, components have been expelled from the container end closure. Furthermore, such larger openings are often difficult to open or impractical to provide in container end closures which are relatively small.

[0005] In various embodiments, vent features of the present invention allow for ease of opening of a content-dispensing portion of the end closure. For example, a vent feature may be forced open prior to the opening of a primary or content-dispensing opening, thus relieving an internal pressure of the container and allowing for easier scoring and opening of the primary opening. It is also contemplated, however, that the vent feature is provided as an optional and/or secondary feature which is opened subsequent to opening of a primary feature.

[0006] In order to produce a more efficient, controlled flow rate, some containers utilize a tab or additional tool to open two or more pour openings. This increases the flow rate of the beverage and provides better control of the liquid stream. Additionally, a second vent hole may be utilized to depressurize a container, and thus allow for easier opening of the dispensing port. This is especially advantageous for carbonated and malt beverages such as beer. Examples are provided in U.S. Patent Nos. 4,205,760; 5,307,947; 5,397,014; 6,024,239; 6,079,583; 7,513,383; 7,748,557; and U.S. Patent Application Publication Nos. 2014/0263333, 2010/0294771 and 2011/0056946; the disclosures of which are incorporated herein by reference in their entirety. However, many prior art end closures with a vent opening may be opened with finger pressure alone and utilize a score residual with a thickness which is prone to prematurely severing, and thus causing leaks or failures during stacking.

[0007] In various known devices, inadvertent depression of a pull tab such as that which may occur during handling, stacking, shipping, etc. may result in inadvertent opening of a vent feature, thus ruining the container and contents. Other vent openings utilize a score with excessive score residual, thus making the vent difficult to open without a secondary tool.

SUMMARY

[0008] Thus, there exists a need to provide a container end closure that provides enhanced pour characteristics through an easy-opening vent feature, while minimizing the likelihood of problems such as bursting, buckling, leakage, opening failures, and the like. Further, there exists a need to provide vent openings which can be opened with a portion of the pull tab, yet prevents inadvertent opening and a positive "ball détente" assembly which identifies proper engagement.

[0009] The present invention is generally directed to systems and methods which provide metallic container end closures with a plurality of openings for improved venting and pour characteristics. The present disclosure discusses opening configurations utilizing

various numbers, positions, shapes, sizes, and orientations of openings. These configurations are presented herein for description purposes and are not intended to limit the scope of the invention.

[0010] In accordance with one embodiment of the present invention, a metallic container end closure is provided that comprises a primary opening and a secondary vent opening. The number of openings may vary in number, size, shape, location, and orientation. In some embodiments, a primary opening provides an aperture for pouring the contents of the container, and a secondary vent opening provides ventilation for air flow through the end panel for enhancing pouring characteristics. In some embodiments, a single primary dispensing opening is provided, and a plurality of vent openings are provided. The plurality of vent openings may provide apertures to vent the container to enhance product flow out of the dispensing opening, to dispense the product at varying flow rates, to accommodate a straw, and/or to allow multiple consumers to drink out of the same container without contacting the same part of the container end closure.

[0011] In addition to varying the number of openings, the size of the openings may vary. Larger openings may be included in an end closure to provide a consumer with a faster dispensing rate. Smaller openings may be included to provide container venting, thus depressurizing the container and providing enhanced pourability. Additionally, smaller openings may be used to dispense contents at a slower rate, which may be advantageous for children. Smaller openings also may be configured to selectively accommodate straws. Such configurations may be desirable for children as the smaller opening reduces the flow rate during spills and the use of a straw may increase the likelihood that the child will drink the product. In one embodiment, a large dispensing opening for dispensing the product and a small vent opening for venting the container is provided. In another embodiment, a large dispensing opening and a large vent opening is provided. In this embodiment, the consumer has two substantially equivalent dispensing options.

[0012] Various opening shapes are contemplated. For example, the opening shapes may be circular, square, bulbous, triangular, curved, arcuate, oval, and other shapes known in the art. Further, the shapes may be symmetrical or non-symmetrical about an axis that bisects the opening area. The shape of the opening may be chosen based on the desired flow rate and the ease of fracturing an associated score. For example, a score with a triangular shape has a stress concentration at the apex of the triangle, thus reducing the amount of force necessary to fracture the score near the apex. Additionally, a triangular

shape will allow an opening tool to focalize the opening force on a smaller area near the apex as opposed to a round score shape.

[0013] The location of the openings on the end closure may vary as well. In some embodiments, a dispensing opening and a vent opening is provided. In these embodiments, the vent opening is selectively located on the container end closure so that when a container is tipped to dispense its contents out of the dispensing opening, the contents do not exit out of the vent opening. This selective location prevents spillage out of the vent opening while dispensing product out of the dispensing opening, and the location increases the smoothness of the pour by providing adequate container venting.

[0014] The orientation of the openings also may vary. In one embodiment, a vent opening is provided on or proximal to a center line of an end closure, the center line generally bisecting the primary opening, a tab provided on the end closure, and the vent opening. The vent opening is positioned within an open area or void in the tab proximal to user-activated end of the tab. The vent is severable and activated by rotating the tab from an original position and depressing a portion of the tab into an upper surface of the vent feature. The vent feature preferably comprises a raised feature or dome to facilitate opening of the vent feature. A portion of the tab may comprise a détente or downwardly extending portion for contacting and opening the vent feature. This allows a consumer to move the pull tab into the proper position for severing the score of the vent opening without needing to visually identify the location of the tab.

[0015] In alternative embodiments, a vent opening is provided offset from a centerline of the closure. Such embodiments include embodiments wherein the vent opening is provided outside of an area defined by a tab when the end closure is provided in a filled and closed state. Although preferred embodiments of the present disclosure comprise a vent opening located on an opposite side of a rivet from a main opening, the present disclosure is not limited to only that embodiment. Rather, it is contemplated that the vent be provided radially offset from such a position, such that a rotation of the tab of between approximately 5 and 120 degrees is required to allow a tail of the tab to contact the vent portion.

[0016] In various embodiments, end closures are contemplated which comprise a stiffening bead or a local vent recess to assure sufficient stiffness within the metal surrounding the vent, thus assuring ease of opening. Local vent recesses comprise a deboss or recess provided on an end closure, wherein the vent is provided within or proximal to the vent recess. Vent recesses of the present disclosure may be provided in

any number of locations, including within a main deboss, external to a main deboss, or provided as an extension to a main deboss. As used herein, a main deboss generally refers to a deboss on a central panel and within which at least a main opening area and a rivet are provided. Such main deboss features include, but are not limited to Stolle-type debosses.

[0017] In various embodiments, the present disclosure comprises an end closure with a vent opening and/or a vent score line having a preferred geometry. Such embodiments contemplate the vent score being provided in any number of positions, including underneath a tail of a tab when a container is in a closed position, or alternatively positioned off-set from the tab when the container is in a closed position. In certain embodiments, a vent is provided comprising a non-circular vent score line. For example, in certain embodiments, a vent is provided with a score line comprising a generally elongate or flat oval form. In preferred embodiments, the generally elongate oval comprises substantially parallel opposing portions and arcuate, mirrored, opposing portions. Furthermore, the hinge point of the vent opening may be positioned in a variety of locations, including proximate to the side next to the rivet, proximate to the peripheral curl or on either end of the oval.

[0018] In various embodiments, end closures are provided comprising a vent opening feature, the vent opening feature comprising a vent score line and an upstanding contact feature provided at least partially within the vent score line. In certain embodiments, the upstanding contact feature comprises a domed member provided on a vent panel, the domed member suitable for contacting with a portion of a tab such as the tail and/or bead of a tab. Such features may be provided on any number of embodiments shown and described herein, and regardless of the location of the vent on the end panel.

[0019] In a preferred embodiment, an end closure with a vent feature is provided on a central panel of the end closure. The end closure comprises a main recess or deboss, with a primary opening at least partially defined by a score line provided therein. The central panel further comprises a rivet, and a stay-on tab secured thereto, the tab comprising a nose portion and a tail portion. The end closure further comprises a vent opening, the vent opening positioned opposite the rivet with respect to the primary opening. The vent opening comprises a vent score line characterized by a flat oval shape. The vent score line comprises first and second substantially parallel score lines spaced apart from one another and joined at corresponding ends by arcuate or semi-circular scores. Although the vent score as described herein is occasionally referred to as comprising distinct elements, such description is provided for illustrative purposes only. It

will be recognized that the vent score line comprises a continuous score feature with different radii of curvature and/or linear portions.

[0020] It is an object of various embodiments of the present invention to provide a raised vent feature that is provided within an aperture of a tab, at least when the vent feature and the tab are provided in a first position and wherein the first position comprises a closed position of the end closure with the primary opening portion and vent feature sealed.

[0021] In accordance with another aspect of the present invention, a metallic container end closure is provided that reduces the difficulty of opening a vent opening. In some embodiments, a stiffening structure is provided that adds stiffness to the deboss area near a secondary score. The stiffening structure may have various shapes and configurations. For example, the stiffening structure may be a raised or recessed portion of the deboss area, such as a bead. Alternatively, the stiffening structure can be a separate element that is coupled to the deboss. By adding stiffness to the deboss near a secondary score, the stiffening structure will reduce deboss deflection and thus any downward force exerted on a secondary gate will be focused on the secondary score. Thus, the opening force required to fracture the secondary score is reduced. Further, in some embodiments, a vent form feature is provided that increases the stiffness of the deboss near a secondary score and provides a seat for an opening tool. In these embodiments, the vent form feature may have various shapes and configurations. For example, the vent form feature may be a raised or recessed portion of the deboss, such as a ramp. Alternatively, the vent form feature can be a separate element that is coupled to the deboss. By adding stiffness to the deboss near a secondary score, the vent form feature reduces the opening force required to fracture a secondary score. By providing a seat for an opening tool, the vent form feature reduces slippage and increases force transfer from an opening tool to a secondary gate associated with a vent opening. Moreover, in some embodiments, a safety fold provides additional stiffness around a vent opening.

[0022] In addition to reducing opening force, the stiffening structures improve opening distance. The stiff panel resists deflection allowing the vent feature panel to be forced further into the can thus creating a larger opening.

[0023] While various embodiments of the present invention contemplate providing a primary opening and a vent opening feature within or on a deboss area of an end closure, it will be expressly recognized that the present invention is not limited to such embodiments. Indeed, it is contemplated that in certain embodiments, the vent feature is

provided external to the deboss area. In preferred embodiments, the vent feature is provided within a radius defined by a pull tab and extending from a rivet that secures the pull tab. However, alternative embodiments are contemplated wherein the vent feature is provided outside of such a radius.

[0024] In accordance with another aspect of the present invention, a metallic container end closure is provided that reduces the chances of a consumer injury. In some embodiments, a tab is provided that comprises a downwardly projecting (i.e. projecting or extending from the tab toward the end closure when the tab and end closure are provided in an assembled state) feature that is rotationally offset from the vent feature when the tab is provided in a first position as described above, and wherein the downwardly projecting feature is adapted to communicate with and apply force to the vent opening feature when the tab is rotated to an opening position.

[0025] As discussed herein, the container and associated container end closure generally is formed of conventional metallic container materials, such as aluminum. However, a container end closure according to certain embodiments of the present invention can be formed of other materials including other metals or metal alloys, plastics, cardboard, paper, fiber reinforced materials, and the like.

[0026] In various embodiments of the present invention, an end closure with a vent feature is provided wherein the vent feature is openable with a tab, the tab being secured to the end closure by a rivet. In such embodiments, no additional or external tools are required to open the vent feature.

[0027] In preferred embodiments of the present invention, a pull tab is provided that at least partially surrounds, covers, or otherwise protects a vent feature. The pull tab, at least when provided in a first position, thereby protects the vent from being inadvertently opened during stacking, shipping, handling, etc.

[0028] In certain embodiments, a location-identifier is provided on the pull tab, such that when the tab is rotated to a position wherein the tab may be used to break open the vent feature, feedback is provided to a user regarding this position. In preferred embodiments, a vent feature is provided on the end closure such that only a small degree of rotation is required to move the tab from a closed or secured position to a position wherein the tab is provided for opening the vent feature.

In certain embodiments, a vent opening is provided within a debossed area of an end closure, thus further protecting the vent from inadvertent opening and/or contact, and allowing indicia or other features to be provided on the central panel of the closure.

[0029] In one embodiment, a vented metallic end closure adapted for interconnection with a container body is provided, the end closure comprising a peripheral curl, a chuck wall extending downwardly from the peripheral curl, a countersink interconnected to a lower end of the chuck wall, a central panel interconnected to the countersink, a deboss connected to the central panel, and a tab interconnected to the deboss and rotatable about a rivet. The deboss has a primary score defining a dispensing opening and a secondary score defining a vent opening. The tab comprises an aperture, the aperture having a diameter equal to or larger than a diameter of the secondary score and adapted to provide visual feedback related to the vent opening. The tab comprises a vent interface portion adapted to contact the vent opening, and wherein the vent interface portion is adapted to transmit a force applied to the tab to the vent opening and break open the secondary score. The vent opening further comprises a hinge portion about which the vent portion may hinge open.

[0030] In one embodiment, the present invention comprises a method of opening a container end closure, the method comprising the steps of: 1) lifting a pull or tail portion of a tab to force a nose portion of the tab into a primary opening; 2) rotating the tab such that a vent interface portion of the tab is aligned with a vent feature; 3) applying a force to the tab to break open the vent feature; and 4) rotating the tab back to an initial rotational position and visually confirming that the vent feature has been opened.

[0031] In an alternative embodiment, the vent feature is opened prior to an opening of primary opening. For example, in one embodiment, a method comprises opening a container end closure by: 1) rotating the tab such that a vent interface portion of the tab is aligned with a vent feature; 2) applying a force to the tab to break open the vent feature; 3) rotating the tab back to an initial rotational position; and 4) lifting a tail portion of a tab to force a nose portion of the tab into a primary opening. This opening sequence may be enhanced by removing pressure within the container after the vent opening is severed, thus requiring less force to open the primary opening.

[0032] In one embodiment, a vented metallic end closure adapted for interconnection to a neck of a container body is provided. The end closure comprises a peripheral curl, a chuck wall extending downwardly from the peripheral curl, a countersink interconnected to a lower end of the chuck wall, a central panel interconnected to the countersink, a deboss provided on the central panel, and a tab interconnected to the deboss and rotatable about a rivet. The deboss comprises a first recess, a primary score that defines a dispensing opening, and a vent opening that comprises a secondary score.

The dispensing opening and the vent opening are provided in opposing relationship on opposite sides of the rivet. A secondary recess is provided within the deboss and adjacent to the secondary score. In preferred embodiments, the secondary recess extends at least partially around the secondary score. The tab comprising a nose end and a pull end, the pull end comprises an aperture that is adapted to provide visual feedback of the vent opening. The aperture is preferably slightly larger than an upstanding feature provided on the vent opening, and smaller than the vent opening itself.

[0033] The pull end of the tab is adapted to contact the vent opening and transmit a force to the vent opening and sever the secondary score. The secondary score comprises first and second linear portions, the first and second linear portions being substantially parallel, and first and second opposed arcuate portions to form a flat-oval shape. The vent opening comprises a raised feature and a vent hinge, and the vent hinge is provided proximal to the rivet such that the vent opening hinges in an opposite direction as the dispensing opening.

[0034] The Summary is neither intended nor should it be construed as being representative of the full extent and scope of the present invention. Moreover, references made herein to "the present invention" or aspects thereof should be understood to mean certain embodiments of the present invention and should not necessarily be construed as limiting all embodiments to a particular description. The present invention is set forth in various levels of detail in the Summary as well as in the attached drawings and the Detailed Description and no limitation as to the scope of the present invention is intended by either the inclusion or non-inclusion of elements, components, etc. in this Summary. Additional aspects of the present invention will become more readily apparent from the Detail Description, particularly when taken together with the drawings.

BRIEF DESCRIPTION OF THE DRAWINGS

[0035] FIG. 1 is a top plan view of an end closure according to one embodiment of the present invention.

[0036] FIG. 2 is a top plan view of the end closure shown in FIG. 1 with the pull tab rotated in a clockwise direction.

[0037] FIG. 3 is a top plan view of an end closure according to one embodiment of the present invention.

[0038] FIG. 4 is a cross-sectional elevation view of an end closure taken at line A-A of FIG. 1.

[0039] FIG. 5 is a cross-sectional elevation view of an end closure taken at line B-B of FIG. 2.

[0040] FIG. 6 is a top plan view of an end closure according to an alternative embodiment of the present invention.

[0041] FIG. 7 is a cross-sectional elevation view of the end closure of FIG. 6 taken at line C-C.

[0042] FIG. 8 is a top plan view of the end closure shown in FIG. 6 with the pull tab removed.

[0043] FIG. 9 is a cross-sectional elevation view of the end closure of FIG. 8 taken at line D-D.

[0044] FIG. 10 is a top plan view of an end closure according to one embodiment of the present invention, and showing the tab, the primary opening and the vent opening in a closed position.

[0045] FIG. 11 is a cross-sectional elevation view of an end closure according to the embodiment of FIG. 10 and taken about line E-E.

[0046] FIG. 12 is a top plan view of an end closure according to one embodiment of the present invention, and showing the tab, the primary opening and the vent opening in a closed position.

[0047] FIG. 13 is a cross-sectional elevation view of an end closure according to the embodiment of FIG. 12 and taken about line F-F.

[0048] FIG. 14A is a top plan view of an end closure according to one embodiment of the present disclosure.

[0049] FIG. 14B is a top plan view of the end closure of the embodiment of FIG. 14A.

[0050] FIG. 14C is a top perspective view of the end closure of the embodiment of FIG. 14A.

[0051] FIG. 15A is a top plan view of the end closure of the embodiment of FIG. 14A.

[0052] FIG. 15B is a top perspective view of the end closure of the embodiment of FIG. 14A.

[0053] FIG. 16A is a top plan view of an end closure according to one embodiment of the present disclosure.

[0054] FIG. 16B is a top plan view of the end closure of the embodiment of FIG. 16A.

[0055] FIG. 16C is a top perspective view of the end closure of the embodiment of FIG. 16A.

[0056] FIG. 17A is a top plan view of the end closure of the embodiment of FIG. 16A.

[0057] FIG. 17B is a top perspective view of the end closure of the embodiment of FIG. 16A.

[0058] FIG. 18A is a top plan view of an end closure according to one embodiment of the present disclosure.

[0059] FIG. 18B is a top plan view of the end closure of the embodiment of FIG. 18A.

[0060] FIG. 18C is a top perspective view of the end closure of the embodiment of FIG. 18A.

[0061] FIG. 19A is a top plan view of the end closure of the embodiment of FIG. 18A.

[0062] FIG. 19B is a top perspective view of the end closure of the embodiment of FIG. 18A.

[0063] FIG. 20 is a top plan view of an end closure according to one embodiment of the present disclosure with a tab provided thereon.

[0064] FIG. 21 is a top plan view of an end closure according to one embodiment of the present disclosure.

[0065] FIG. 22 is a top plan view of an end closure according to one embodiment of the present disclosure.

[0066] FIG. 23 is a top plan view of an end closure according to one embodiment of the present disclosure.

[0067] FIG. 24 is a top plan view of a vent feature according to one embodiment of the present disclosure.

[0068] FIG. 25 is a top plan view of a vent feature according to one embodiment of the present disclosure.

[0069] FIG. 26 is a top plan view of a vent feature according to one embodiment of the present disclosure.

[0070] FIG. 27 is a top plan view of an end closure with a vent feature according to one embodiment of the present disclosure.

[0071] FIG. 28 is a top plan view of an end closure with a vent feature according to one embodiment of the present disclosure.

[0072] FIG. 29 is a top plan view of an end closure with a vent feature according to one embodiment of the present disclosure.

[0073] FIG. 30 is a top plan view of an end closure with a vent feature according to one embodiment of the present disclosure.

[0074] FIG. 31 is a top plan view of an end closure with a vent feature according to one embodiment of the present disclosure.

[0075] FIG. 32 is a top plan view of an end closure with a vent feature according to one embodiment of the present disclosure.

[0076] FIG. 33 is a top plan view of an end closure with a vent feature according to one embodiment of the present disclosure.

[0077] FIG. 34 is a top plan view of an end closure with a vent feature according to one embodiment of the present disclosure.

[0078] FIG. 35 is a top plan view of an end closure with a vent feature according to one embodiment of the present disclosure.

[0079] FIG. 36 is a top plan view of an end closure with a vent feature according to one embodiment of the present disclosure.

[0080] To assist in the understanding of the drawings, the following is a list of components and associated numbering found in the drawings:

#	<u>Components</u>
2	End closure
4	Central panel
5	Deboss
6	Peripheral curl
8	Primary opening
10	Primary score
12	Tab
14	Rivet
16	Vent protuberance
18	Tab orienting feature
20	Vent opening
22	Vent cover portion
24	Dome feature

#	<u>Components</u>
26	Vent orienting feature
28	Tail portion
30	Nose portion
32	Hinge
34	Vent score
36	First tier
38	Second tier
40	First tier
42	Second tier
50	End closure
52	Peripheral curl
54	Countersink
56	Central Panel
58	Primary opening
60	Primary score
62	Rivet
64	Secondary vent
66	Vent panel
68	Upstanding domed feature
70	Vent score
72	Anti-fracture score
74	Stiffening bead
76	Primary recess
78	Vent hinge
80	End closure
82	Peripheral curl
84	Countersink
86	Central panel
88	Primary opening
90	Primary score
92	Rivet
94	Secondary vent

<u>#</u>	<u>Components</u>
96	Vent panel
98	Upstanding dome portion
100	Vent score
102	Anti-fracture score
104	Stiffening bead
106	Main recess
108	Vent hinge
120	End closure
122	Peripheral curl
124	Countersink
126	Central panel
128	Main recess
130	Primary opening
132	Primary score
134	Rivet
136	Secondary recess
138	Vent feature
140	Anti-fracture feature
142	Vent score
144	Upstanding dome portion
146	Vent hinge
200	Aperture
220	Vent feature
222	Vent score
224	Raised feature
226	Vent hinge
230	Vent feature
232	Vent score
234	Raised feature
236	Vent score
240	Vent feature
242	Vent score

<u>#</u>	<u>Components</u>
244	Raised feature
246	Vent score
249	End closure
250	Secondary recess
251	End closure
252	Secondary recess
253	End closure
254	Secondary recess
255	End closure
256	Secondary recess
257	End closure
258	Vent feature
260	Vent feature
261	End closure
262	Secondary recess
263	End closure
264	Secondary recess
265	End closure
266	Secondary recess
267	End closure
268	Secondary recess
270	End closure
272	Panel
274	Peripheral curl
276	Deboss
278	Primary opening
280	Primary score
282	Vent feature
284	Vent score
286	Vent hinge
288	Dome portion
290	Secondary recess

#	<u>Components</u>
292	Rivet
294	Tab access feature
300	Vent feature
302	Vent feature
304	Vent feature
306	Vent feature
308	Vent feature
310	Vent feature
312	Vent feature
314	Vent feature

DETAILED DESCRIPTION

[0081] FIG. 1 is a top plan view of one embodiment of an end closure 2 according to the present invention. FIG. 1 depicts the end closure 2 in a first position, wherein the first position comprises a closed position prior to opening of the primary opening 8 or vent feature 20. The end closure 2 comprises a central panel 4, a peripheral curl 6 for securing the end closure to the neck of a container, and a tab 12 interconnected to the deboss 5 by a rivet 14. The deboss 5 comprises a primary opening 8 which is severable at a primary score line 10 to open the primary opening 8 and allow for container contents to be dispensed. A vent feature 20 is provided on an opposing side of the rivet 14 from the primary opening portion 8. The vent feature 20 is visible through and exposed by a tab orienting feature 18 in the arrangement and position depicted in FIG. 1. The tab orienting feature 18 of the depicted embodiment comprises an aperture or through hole in the tab 12. The tab orienting feature 18 is depicted as comprising a generally circular opening in FIG. 1, but it will be expressly recognized that various shapes and sizes for the tab orienting feature 18 are contemplated. In various embodiments, it is contemplated that the tab orienting feature 18 comprises the same or similar shape as the vent feature 20 and wherein the tab orienting feature 18 comprises a slightly larger dimension of similar shape as the vent 20. However, the present invention is not so limited and various sized and shapes are contemplated for use with the tab orienting feature 18.

[0082] In FIG. 1, the vent feature 20 is visible through the tab orienting feature 18. Thus, a user or consumer can readily see that the vent 20 is closed and available for opening. In addition to providing visual information on the vent 20, the tab orienting

feature 18 also provides a recess that prevents force transmission to the vent 20 in the event that the tab 12 is depressed during shipping, stacking, etc. of filled containers. The tab 12 is rotatable by grasping a tail portion 28 of the tab and forcing a nose portion 30 of the tab into the primary opening 8, as will be recognized by one of ordinary skill in the art. Before or after the primary opening 8 is activated, the tab 12 may be rotated about a longitudinal axis of the container extending through the rivet 14 to align a vent protuberance 16 provided on the tab 12 with the vent 20. In certain embodiments, the vent protuberance 16 comprises a détente or downwardly projecting feature of the tab for positioning over the vent feature 20 and transmitting a force to open the feature, as shown and described herein. Although FIGS. 1-3 depict the primary opening 8 as being closed during vent opening operations, it will be expressly recognized that the present invention contemplates first opening the primary opening 8 prior to opening the vent feature 20.

[0083] The tab 12 of the depicted embodiment comprises a vent cover portion 22. Various known tabs comprise a pull-ring style device, with a void provided in the region depicted as the vent cover portion 22 of FIGS. 1-3. In contrast with such prior art devices, the embodiment of FIGS. 1-3 provide a vent cover portion that comprises a solid portion of the tab 12 with a vent protuberance 16 and tab orienting feature 18 are provided thereon. In an alternative embodiment, however, a large aperture is provided in lieu of the vent covering portion, and a vent protuberance 16 is provided on a remainder of the tab 12.

[0084] FIG. 2 is a top plan view of an end closure 2 according to the embodiment of FIG. 1 wherein the tab 12 has been rotated to a position suitable for opening the vent 20. As shown, the tab 12 has been rotated about an axis extending through the rivet 14 such that the tab orienting feature has been moved radially away from the vent 20 and the vent protuberance 16 of the tab is positioned over the vent 20. Thus, in the position depicted in FIG. 2, a downward force applied to the tab 12 will be transmitted through the tab 12 and the vent protuberance 16 to the vent portion 20. The vent portion may thus be opened by said force, which severs a score line defining the vent, and wherein the vent 20 is openable about a hinge 32.

[0085] As further shown in FIG. 2, an offset angle α is provided. The offset angle α is the angle of rotation required to translate the tab 12 from a first closed position to a second position wherein the second position is adapted for opening the vent protuberance 16. In various embodiments, the offset angle α is contemplated as being between approximately 5 degrees and approximately 30 degrees. In preferred embodiments, the

offset angle α is contemplated as being between approximately 10 degrees and approximately 25 degrees. In one preferred embodiment, the offset angle α is contemplated as being at least approximately 15 degrees and preferably no greater than approximately 20 degrees. Although FIG. 2 depicts an end closure with a tab 12 rotated in a clockwise direction, certain embodiments provide that the tab 12 should preferably rotated in a counterclockwise direction. Where a vent feature is opened prior to opening the primary opening 8, subsequent attempts at opening the primary opening 8 with the tab 12 still provided in the position of FIG. 2 may cause complications with the opening of the primary opening 8 including tongue tear and hinge fracture. Therefore, in certain embodiments the present disclosure provides methods and devices wherein opening of the vent requires counter-clockwise rotation of the tab, including embodiments wherein a vent feature is provided in a position that requires such rotation in order for a tail portion of the tab to contact the vent feature.

[0086] FIG. 3 is a top plan view of an end closure 2 according to the embodiment of FIGS. 1-2 and wherein the vent opening 20 has been opened. When rotated back to the position of FIG. 1, the tab orienting feature 18 provides visual information to a user that the vent feature 20 has been opened and is ready for venting and facilitating pouring of contents through the primary opening 8 by enhancing air flow characteristics.

[0087] FIGS. 4-5 are cross-sectional elevation views of an end closure 2 according to one embodiment of the present invention in first and second positions, respectively. FIG. 4 is a cross-section taken about line A-A of FIG. 1 depicting the end closure 2 with a vent feature 20 provided on the deboss 5. The vent feature 20 comprises a generally convex protrusion 24 with a concave portion 26. The concave portion 26 is provided to receive and communicate with vent protuberance 16 as shown and described herein. In the position depicted in FIG. 4, the tab orienting feature 18 is disposed directly over the vent opening 20. As shown, the vent cover portion 22 is provided radially outwardly from the tab orienting feature and the vent opening 20. The tab orienting feature comprises an opening or void in the tab 12. Thus, if the tab 12 and/or vent cover portion 22 is depressed or deflected downwardly, the vent 20 is not accidentally depressed or broken open.

[0088] FIG. 5 is a cross-sectional view of the end closure 2 taken about line B-B of FIG. 2, wherein the tab 12 has been rotated such that the vent protuberance 16 is provided in contact with the concave portion 26 of the vent opening 20. The relative position of the tab 12 and vent feature 20 shown in FIG. 5 are provided for opening the vent feature 20.

Specifically, a downward force applied to the tab 12 as provided in FIG. 5 will force open the vent 20.

[0089] FIGS. 6-9 depict one embodiment of an end closure 2 with a vent feature 20. FIGS. 6-7 depict the end closure with a tab 12 operable to open the vent feature 20, and FIGS. 8-9 depict an end closure of the same embodiment with the tab 12 removed. FIG. 6 is a top plan view of an end closure 2 according to one embodiment of the present invention wherein a tab 12 is provided, the tab 12 operable to open a dispensing opening 8 and a vent feature 20. In the position of FIG. 6, the vent feature 20 is disposed beneath a tab orienting feature 18. The tab 12 further comprises a vent interface portion 16 provided on a vent cover portion 22. The tab 12 is rotatable about a rivet 14 such that the vent protuberance 16 may be disposed over or in contact with the vent feature 20. The tab 12 and vent protuberance 16 may be forced downwardly to apply a force to and break open the vent feature 20. FIG. 7 is a cross-sectional elevation view of the end closure 2 taken about line C-C of FIG. 6. As shown in FIG. 7, the tab orienting feature 18 comprises an aperture or void in the vent cover portion 22 of the tab 12. In the closed position of FIG. 7, wherein the tab orienting feature 20 is provided over and substantially concentric with the vent 20, it will be recognized that a downward force applied to the tab 12 will generally not impact or break open the vent 20.

[0090] FIG. 8 is a top plan view of the end closure of the embodiment of FIG. 6. FIG. 9 is a cross-sectional elevation view taken at line D-D of FIG. 8. FIGS. 8-9 depict the end closure without the tab, and thus reveal various score lines. The vent feature 20 comprises a vent score line 34 adapted to be broken open when a tab 12 is used to apply a force to the vent feature 20. The score 34 is generally circular in the depicted embodiment, but is not a closed circle as a hinge portion 32 is provided to connect the vent 20 to the central panel 4 and allow the vent 20 to hinge open. Although the vent hinge 32 is provided at a location generally between the vent 20 and the rivet 14, it will be expressly recognized that the hinge 32 may be provided at any number of radial positions with respect to the vent 20.

[0091] FIGS. 10-11 depict an end closure 2 according to one embodiment of the present invention. FIG. 10 is a top plan view of the end closure 2. FIG. 11 is a cross-sectional elevation view of the end closure 2 taken at line E-E of FIG. 10. The embodiment of FIGS. 10-11 comprises a vent cover portion 22 having a tab orienting feature 18 and a vent interface portion 16. The vent cover portion 22 of the depicted embodiment comprises a stepped or tiered structure with a first tier 36 and second tier 38

as shown in FIG. 11. The vent interface portion 16 is provided in an alternative position wherein the tab must be rotated counter-clockwise from the position shown in FIG. 10 to utilize the vent interface portion 16. It will be recognized that the vent interface portion 16 may be provided in a number of different positions.

[0092] FIGS. 12-13 depict an end closure 2 according to one embodiment of the present invention. FIG. 12 is a top plan view of the end closure 2. FIG. 13 is a cross-sectional elevation view of the end closure 2 taken at line F-F of FIG. 12. The embodiment of FIGS. 12-13 comprises a vent cover portion 22 having a tab orienting feature 18 and a vent interface portion 16. The vent interface portion 16 of the depicted embodiment comprises a stepped or tiered structure with a first tier 40 and second tier 42 as shown in FIG. 13.

[0093] FIG. 14A is a top plan view of an end closure according to one embodiment of the present invention. As shown, the end closure 50 comprises a peripheral curl 52 for securing the end closure to a container body, and a countersink 54. The end closure 50 comprises a central panel 56 located interior to the countersink 54. The central panel 56 comprises a main deboss or recess 76 within which a primary opening area 58 is provided. The primary opening area 58 comprises a tear panel for opening the end closure and allowing the container contents to be dispensed. The primary opening area 58 comprises a main score 60, which is severable by applying a force to the opening area 58 with the nose of a tab (not shown) secured to the end closure 50 at a rivet 62. The end closure 50 further comprises a secondary opening or vent feature 64. In the depicted embodiment, the vent feature 64 comprises a substantially flat oval shape. The vent feature 64 further comprises a vent score 70 and an anti-fracture feature 72. The vent feature 64 further comprises a vent hinge 78 about which the vent feature rotates during an opening operation. The vent feature 64 further comprises an upstanding dome portion 68 adapted for contact with a tail end of the tab (not shown) to force open the vent feature. In certain embodiments, and as shown in FIG. 14A, the end closure 50 further comprises a stiffening bead 74. The bead 74 may be provided to stiffen the panel 56, or to account for slack metal created during the formation of the vent score 70 and/or the anti-fracture score 72. The bead 74 of FIG. 14A comprises a geometry wherein the bead 74 extends only partially around the vent feature 64. In alternative embodiments, the end closure is devoid of the bead 74, and the end closure 50 comprises a vent feature 64 provided within a main recess 76 and the end closure 50 is devoid of additional beads or similar features (i.e. apart from main recess 76).

[0094] FIGS. 14B-14C are top plan and top perspective views of the end closure 50 according to the embodiment of FIG. 14A. FIG. 14B, as shown, depicts an end closure with a primary opening area 58 comprising an aperture area of between approximately 0.25 square inches and approximately 1.0 square inch, and preferably approximately 0.56 square inches.

[0095] FIG. 15A is a top plan view of the end closure 50 according to the embodiment of FIG. 14A and comprising exemplary dimensions. More specifically, as appreciated by one of skill in the art, the dimensions may be varies based on the size of the end closure, size of the primary opening, and other factors. As shown, an end closure 50 is provided with a vent feature 64 provided within a main deboss 76. The vent score 64 comprises a width B of between approximately 0.125 inches and approximately 0.50 inches, and preferably between approximately 0.300 inches and 0.350 inches. The vent score 70 comprises a height G (provided substantially perpendicular to the width) that is between approximately 0.10 and 0.20 inches, and preferably approximately 0.165 inches from the hinge 78 to the score line 70. In various embodiments, and as shown in FIG. 15A, a portion of the vent score 70 is provided proximal to an edge of the upstanding dome portion 68. As shown, a portion of the vent score 70 is offset from an edge of the upstanding dome portion by a gap D, wherein the gap D is less than approximately 0.025 inches from an edge of the upstanding dome portion 68. Preferably, the gap D comprises a distance of between approximately 0.012 inches and 0.014 inches. As shown, the vent feature 64 generally comprises a flat oval shape with a vent hinge 78 provided between the rivet and the upstanding dome portion 68. In the depicted embodiment, the vent feature 64 is adapted to hinge inwardly toward a product side of the end closure 50 and wherein score propagation begins at a point on the vent score 70 opposite the dome portion 68 with respect to the rivet.

[0096] As further shown in Fig. 15A, the vent score 70 is offset from a secondary recess 74 in the form of a stiffening bead by a dimension E. In various embodiments, the dimension E comprises a distance of between approximately 0.075 and 0.10 inches, and preferably of approximately 0.083 inches. A distance F between a center point of the dome portion 68 and a portion of the vent score 70 preferably comprises a distance of between approximately 0.070 inches and 0.090 inches, and more preferably comprises a distance of approximately 0.078 inches. A distance between the vent hinge 78 and a center point of the dome portion 68 is shown as dimension H, wherein dimension H preferably comprises a distance of between approximately 0.070 and 0.10 inches, and

preferably of between approximately 0.077 and 0.087 inches. A first width G of the vent feature 64 comprises a width of between approximately 0.140 and 0.180 inches, and preferably of between approximately 0.155 and 0.165 inches. A lateral distance C is provided between a center point of the dome portion 68 and a portion of the vent score 70, wherein the lateral distance C comprises a distance of between approximately 0.140 inches and 0.180 inches, and preferably of between approximately 0.150 and 0.175 inches. The dome portion 68 comprises a width I of between approximately 0.10 and 0.20 inches, and preferably of between approximately 0.128 and 0.132 inches. The width I generally comprises a dimension across the dome portion 68 between opposing intersections of the dome portion and the vent panel. In certain embodiments, the dome portion 68 comprises a hemisphere. In such embodiments, the width I comprises a diameter of the dome portion 68. In alternative embodiments, however, it is contemplated that dome portion 68 is not a complete hemisphere and/or is provided on the vent panel such that a distance across the base of the dome portion 68 does not comprise a diameter.

[0097] The embodiment of FIGS. 14A-15B comprises a secondary recess 74 in the form of a stiffening bead extending at least partially around the vent feature 64. The secondary recess 74 is provided to account for slack metal created during formation of the vent score 70 and anti-fracture feature 72 and/or is provided as an access point for an underside of a tail portion of a tab (not shown). Although various embodiments of an end closure are provided herewith that comprise a secondary recess, additional embodiments of the present disclosure contemplate an end closure that is devoid of a secondary recess. For example, the vent feature of any one or more of the various embodiments shown and described herein may be provided wherein no secondary recess is provided, at least in connection with the vent feature.

[0098] FIGS. 16A-17B depict an end closure 80 comprising numerous features as shown and described herein with respect to FIGS. 14A-15B, including a peripheral curl 82, countersink 84, central panel 86, main opening area 88, opening area score line 90, a rivet 92, a main deboss 106, and a vent feature 94 comprising a vent panel 96, an upstanding domed portion 98, vent score 100, anti-fracture score 102, and a vent hinge 108. A stiffening bead 104 is provided generally adjacent to the vent feature 94. The stiffening bead is provided to account for slack metals, provide strength to the end closure, and/or allow for access to an underside of the tab.

[0099] As further shown in Fig. 17A, the vent score 100 is offset from a secondary recess 104 in the form of a stiffening bead by a dimension E'. In various embodiments,

the dimension E' comprises a distance of between approximately 0.075 and 0.10 inches, and preferably of approximately 0.083 inches. A distance F between a center point of the dome portion 98 and a portion of the vent score 100 preferably comprises a distance of between approximately 0.070 inches and 0.090 inches, and more preferably comprises a distance of approximately 0.078 inches. A distance between the vent hinge 108 and a center point of the dome portion 98 is shown as dimension H, wherein dimension H preferably comprises a distance of between approximately 0.070 and 0.10 inches, and preferably of between approximately 0.077 and 0.087 inches. A first width G of the vent feature 94 comprises a width of between approximately 0.140 and 0.180 inches, and preferably of between approximately 0.155 and 0.165 inches. A lateral distance C is provided between a center point of the dome portion 98 and a portion of the vent score 100, wherein the lateral distance C comprises a distance of between approximately 0.140 inches and 0.180 inches, and preferably of between approximately 0.150 and 0.175 inches. The dome portion 98 comprises a width I of between approximately 0.10 and 0.20 inches, and preferably of between approximately 0.128 and 0.132 inches. The width I generally comprises a dimension across the dome portion 98 between opposing intersections of the dome portion and the vent panel. In certain embodiments, the dome portion 98 comprises a hemisphere. In such embodiments, the width I comprises a diameter of the dome portion 98. In alternative embodiments, however, it is contemplated that dome portion 98 is not a complete hemisphere and/or is provided on the vent panel such that a distance across the base of the dome portion 98 does not comprise a diameter.

[00100] Figs. 18A-19B depict an end closure 120 according to one embodiment of the present disclosure. As shown, the end closure 120 comprises a peripheral curl 122 for securing the end closure to a container body, and a countersink 124. The end closure 120 comprises a central panel 126 located interior to the countersink 124. The central panel 126 comprises a main deboss or recess 128 within which a primary opening area 130 is provided. The primary opening area 130 comprises a tear panel for opening the end closure and allowing container contents to be dispensed. The primary opening area 130 comprises a main score 132, which is severable by applying a force to the opening area 130 with the nose of a tab (not shown) secured to the end closure 120 at a rivet 134.

[00101] The end closure 120 further comprises a secondary opening or vent feature 138. In the depicted embodiment, the vent feature 138 comprises a substantially flat oval shape. The vent feature 138 comprises a vent score 142 and an anti-fracture feature 140. The vent feature 138 further comprises a vent hinge 146 about which the vent feature

rotates during an opening operation. The vent feature 138 further comprises an upstanding dome portion 144 adapted for contact with a tail end of the tab (not shown) to force open the vent feature. In certain embodiments, and as shown in FIG. 18A, the end closure 120 further comprises a vent recess 136. The vent recess 136 may be provided to stiffen the panel 56, or to account for slack metal created during the formation of the vent score 142 and/or the anti-fracture score 140. The vent recess 136 of FIG. 18A comprises a recess that substantially surrounds and contains the vent feature 138. The vent feature 138 of the depicted embodiment is provided completely within the main recess 128. Alternative embodiments contemplate the vent recess 136 being provided external to the main recess 128 or as an extension of the main recess 128.

[00102] FIGS. 18B-18C are top plan and top perspective views of the end closure 120 according to the embodiment of FIG. 18A. FIG. 18B, as shown, depicts an end closure with a primary opening area 130 comprising an aperture area of between approximately 0.25 square inches and approximately 1.0 square inches, and preferably approximately 0.56 square inches.

[00103] FIG. 19A is a top plan view of the end closure 120 according to the embodiment of FIG. 18A. The dimensions provided in FIG. 18A are provided for illustrative purposes of one particular embodiment of the present disclosure. Exemplary dimensions as shown herein with respect to FIG. 19A and other figures are provided to illustrate specific embodiments of the disclosure. The inventions discussed herein are not limited to the depicted dimensions. As shown, an end closure 120 is provided with a vent feature 138 provided within a main deboss 128. The vent score 142 comprises a width of between approximately 0.125 inches and approximately 0.50 inches, and preferably approximately 0.350 inches. The vent score 142 comprises a height (provided substantially perpendicular to the width) that is between approximately 0.10 and 0.20 inches, and preferably approximately 0.165 inches from the hinge 146 to the score line 142. In various embodiments, and as shown in FIG. 19A, a portion of the vent score 142 is provided proximal an edge of the upstanding dome portion 144. As shown, a portion of the vent score 142 is positioned less than approximately 0.025 inches from an edge of the upstanding dome portion 144. Preferably, an edge of the upstanding dome portion 144 is provided approximately 0.014 inches from a portion of the vent score 142. As shown, the vent feature 138 generally comprises a flat oval shape with a vent hinge 146 provided between the rivet and the upstanding dome portion 144. In the depicted embodiment, the vent feature 138 is adapted to hinge inwardly toward a product side of the end closure 120

and wherein score propagation begins at a point on the vent score 142 opposite the dome portion 144 with respect to the rivet.

[00104] As further shown in Fig. 19A, the vent score 142 is provided within a secondary recess 136. In various embodiments, a distance E'' is provided between an edge of the secondary recess 136 and the vent score 142. Preferably, the dimension E'' comprises a distance of between approximately 0.050 and 0.10 inches, and preferably of approximately 0.073 inches. A distance F between a center point of the dome portion 144 and a portion of the vent score 142 preferably comprises a distance of between approximately 0.070 inches and 0.090 inches, and more preferably comprises a distance of approximately 0.078 inches. A distance between the vent hinge and a center point of the dome portion 144 is shown as dimension H, wherein dimension H preferably comprises a distance of between approximately 0.070 and 0.10 inches, and preferably of between approximately 0.077 and 0.087 inches. A first width G of the vent feature 138 comprises a width of between approximately 0.140 and 0.180 inches, and preferably of between approximately 0.155 and 0.165 inches. A lateral distance C is provided between a center point of the dome portion 144 and a portion of the vent score 142, wherein the lateral distance C comprises a distance of between approximately 0.140 inches and 0.180 inches, and preferably of between approximately 0.150 and 0.175 inches. The dome portion 144 comprises a width I of between approximately 0.10 and 0.20 inches, and preferably of between approximately 0.128 and 0.132 inches. The width I generally comprises a dimension across the dome portion 144 between opposing intersections of the dome portion and the vent panel. In certain embodiments, the dome portion 144 comprises a hemisphere. In such embodiments, the width I comprises a diameter of the dome portion 144. In alternative embodiments, however, it is contemplated that dome portion 144 is not a complete hemisphere and/or is provided on the vent panel such that a distance across the base of the dome portion 144 does not comprise a diameter.

[00105] FIGS. 14A-19B depict a vent feature provided within a main recess or deboss and provided in a specific location with respect to the rivet and other elements of the end closure. It will be expressly recognized that the vent feature(s) shown herein may be provided at various alternative locations on the central panel of the end closure(s). Indeed, alternative embodiments contemplate providing the vent feature and/or stiffening bead at different locations including outside of the main deboss, or wherein the bead or recess comprises an extension of the main recess. Furthermore, the present disclosure is

not limited to end closures that comprise a single vent. End closures are contemplated as comprising a plurality of the vent features shown and described herein.

[00106] FIG. 20 is a top plan view of an end closure according to one embodiment of the present disclosure with a tab 12 provided therein. The tab 12 is secured to a rivet on the end closure, and comprises an aperture 200 revealing an upstanding dome portion of a vent feature. In the closed and sealed position of FIG. 20, unwanted opening of the vent feature is avoided at least by the provision of the aperture 200. The aperture 200 also provides a visual indicia to indicate to a user that a vent feature exists beneath the tab. Opening of the vent is possible by rotating the tab 12 about the rivet and applying a downward force on the upstanding vent feature with an underside of the tail portion of the tab 12.

[00107] FIGS. 21-23 are top plan views of the end closures shown in FIGS. 18A, 14A, and 16A, respectively and without a tab provided thereon. The tab 12 of FIG. 20 may be provided on any one of the end closures shown in FIGS. 21-23.

[00108] FIG. 24 is a top view of a vent feature 220 according to one embodiment of the present disclosure. As shown, the vent feature 220 comprises a vent score 222 about which the vent may be separated or opened with respect to a remainder of the end closure at or about a vent hinge 226. A raised feature 224 is provided within the vent score 222 and the vent hinge 226. The raised feature 224 of the embodiment of FIG. 24 comprises a domed or partially-spherical feature extending at least partially above the vent feature 220. A perimeter line is shown in FIG. 24 to generally indicate the limits or boundary of the raised feature 224. Relative dimensions of the embodiment of FIG. 24 are provided, wherein a distance X is shown as comprising a lateral distance between a center of the raised feature and the score line 222 of the vent feature 220. A distance Y is shown and comprises a distance from the center of the raised feature 224 and the vent hinge 226. A distance Z is provided, distance Z comprising the distance between the center of the raised feature 224 and a portion of the score line 222 provided opposite the vent hinge. The embodiment of FIG. 24 comprises a vent feature 220 with a raised portion 224 and a vent hinge 226 and wherein the vent score 222 and the vent hinge 226 are provided substantially concentric with the raised feature 224. Specifically, illustrated dimensions are provided wherein X is substantially equivalent to Y and to Z.

[00109] FIG. 25 is a top view of a vent feature 230 according to yet another embodiment of the present disclosure. The vent feature 230 comprises a vent score 232, a raised feature 234 and a vent hinge 236. The vent feature 230 of FIG. 25 comprises an

elongated vent with a distance X between a center of the raised feature 234 and a lateral portion of the vent score 232, a distance Y between a center of the raised feature 234 and the vent hinge 236, and a distance Z between a center of the raised feature 234 and a portion of the vent score 232 opposite the vent hinge. In the embodiment of FIG. 25, distance X is approximately equal to distance Z. Distance Y comprises a distance that is approximately 1.5Z. It will be recognized that distance Y may be varied based on various parameters, but preferably comprises a distance between approximately 1.2Z and 3.0Z.

[00110] FIG. 26 is a top view of a vent feature 240 according to yet another embodiment of the present disclosure. As shown, the vent feature 240 comprises a vent score 242, a raised feature 244 and a vent hinge 246. The vent score 242 and a perimeter of the raised feature 244 comprise a substantially flat oval shape. A distance A is provided, the distance A comprises a distance or spacing between the vent score 242 and a perimeter of the raised feature 244. In the embodiment of FIG. 26, the distance A is substantially constant around the perimeter of the raised feature 244.

[00111] FIGS. 24-26 depict vent features of various embodiments of the present disclosure. The vent features of FIGS. 24-26 may be provided in various locations on an end closure, including within a main deboss, external to a main deboss, and within a local recess feature (which may further be provided in various locations on the end closure).

[00112] FIGS. 27-35 depict end closures in accordance with various embodiments of the present disclosure. The various embodiments contemplate different vent features and/or stiffening beads. The features and functions of vent features and stiffening beads as described herein apply to the embodiments of FIGS. 27-35, which are provided to illustrate that various modifications to such features are contemplated. Such modifications may be desirable based on can or end closure size, aesthetic purposes, or various other reasons. FIGS. 27-35 provide various end closures 249, 251, 253, 255, 257, 261, 263, 265, 267 with various combinations of vent openings 300, 302, 304, 306, 258, 260, 308, 310, 312, 314 and secondary recesses 250, 252, 254, 256, 262, 264, 266, 268. It will be recognized that various vent openings as shown and described in this disclosure may be combined with various stiffening structures and secondary recesses shown and described herein, and that the present disclosure is not limited to the particular combinations and embodiments provided in the figures.

[00113] FIG. 36 is a top plan view of an end closure 270 according to one embodiment of the present disclosure. As shown, the end closure 270 comprises a central panel 272 with a peripheral curl 274 extending therefrom and wherein the end closure 270

is adapted to be secured to a container body (not shown). The central panel 272 comprises a deboss 276 within which is provided a primary opening 278 that is openable via a primary score line 280. A tab (not shown) may be attached to the central panel 272 by a rivet 292. Opposite the rivet 292 from the primary opening 278 is a vent opening 282. The vent opening 282 comprises a vent score 284 and a vent hinge 286. The vent score 284 comprises an oval or ovoid shape with various radii of curvature. The vent score 284 defines a severable score line about which the vent opening 282 can be forced open. The vent opening 282 comprises a button or domed portion 288 comprising a semi-circular member extending upwardly toward a public side of the closure. A curvilinear secondary recess 290 is provided external to and at least partially surrounding the vent feature 282 and vent panel 292. The secondary recess 290 is provided to account for slack metal, increase panel stiffness, and/or assist with opening of the vent feature 282. As shown in FIG. 36, the closure further comprises a tab access feature 294 to enhance access to an underside of a tab and assist a user in opening operations. The tab access feature 294 also provides enhanced stiffness to the panel, and in certain embodiments comprises a means for accounting for slack metal created in the manufacturing process.

[00114] The description of the present invention has been presented for purposes of illustration and description, but is not intended to be exhaustive or limiting of the invention to the form disclosed. Many modifications and variations will be apparent to those of ordinary skill in the art. The embodiments described and shown in the figures were chosen and described in order to best explain the principles of the invention, the practical application, and to enable those of ordinary skill in the art to understand the invention.

[00115] While various embodiments of the present invention have been described in detail, it is apparent that modifications and alterations of those embodiments will occur to those skilled in the art. Moreover, references made herein to “the present invention” or aspects thereof should be understood to mean certain embodiments of the present invention and should not necessarily be construed as limiting all embodiments to a particular description. It is to be expressly understood that such modifications and alterations are within the scope and spirit of the present invention.

CLAIMS

What is claimed is:

1. A vented metallic end closure adapted for interconnection to a neck of a container body, comprising:

a peripheral curl;

a chuck wall extending downwardly from the peripheral curl;

a central panel positioned within the chuck wall;

a deboss provided on the central panel;

a tab interconnected to the deboss and rotatable about a rivet;

a primary score defining a dispensing opening and a vent opening comprising a secondary score provided with the deboss;

wherein the dispensing opening and the vent opening are provided in opposing relationship on opposite sides of the rivet;

a secondary recess provided within the deboss and wherein the secondary recess is adjacent to and extends at least partially around the secondary score;

the tab comprising a nose end and a pull end, said pull end comprising an aperture, the aperture adapted to provide visual feedback of the vent opening;

wherein the pull end of the tab is adapted to contact the vent opening, and wherein the tab is adapted to transmit a force to the vent opening and sever the secondary score;

the secondary score comprising first and second linear portions, the first and second linear portions being substantially parallel, and first and second opposed arcuate portions;

the vent opening comprising a raised feature and a vent hinge; and

wherein the vent hinge is provided positioned such that the vent opening hinges in an opposite direction as the dispensing opening.

2. The vented metallic end closure of claim 1, wherein the aperture in the tab is larger than the raised feature of the vent opening, and smaller than the vent opening.

3. The vented metallic end closure of claim 1, wherein the raised feature comprises a convex feature positioned within the secondary score which extends toward a public side of the end closure.

4. The vented metallic end closure of claim 1, wherein the vent opening is positioned within the secondary recess.

5. The vented metallic end closure of claim 1, wherein the pull end of the tab comprises a downwardly projecting portion for contacting the vent opening.

6. The vented metallic end closure of claim 1, wherein a center point of the vent opening is radially offset from a center line of the end closure by at least approximately 15 degrees.

7. The vented metallic end closure of claim 1, wherein a center point of the vent opening is provided at a lateral midpoint of the end closure.

8. The vented metallic end closure of claim 1, wherein the secondary score and the vent hinge collectively comprise a flat oval shape.

9. A vented metallic end closure adapted for interconnection to a neck of a container body, comprising:

a peripheral curl;

a chuck wall extending downwardly from the peripheral curl;

a central panel positioned inwardly from the chuck wall;

a deboss provided on the central panel;

a tab interconnected to the central panel and rotatable about a rivet;

the deboss defining an opening area comprising a dispensing opening and a vent opening;

the dispensing opening comprising a primary score line and the vent opening comprising a secondary score line and a vent hinge;

a secondary recess provided adjacent to and extending at least partially around the vent opening;

the tab comprising a nose end and a pull end;

wherein the pull end of the tab is adapted to contact the vent opening, and wherein the tab is adapted to transmit a force to the vent opening and sever the secondary score;

the secondary score comprising an oval score line at least partially surrounding a vent panel;

an upstanding dome portion provided on the vent panel, the upstanding dome portion comprising a center that is spaced apart from the vent hinge by at least approximately 0.070 inches; and

wherein the secondary recess is spaced apart from the secondary score line by at least approximately 0.080 inches.

10. The vented metallic end closure of claim 9, wherein the secondary score line is provided beneath the tab at least when the container is in a first closed position.

11. The vented metallic end closure of claim 9, wherein the upstanding dome portion comprises a convex feature positioned within the secondary score which extends outwardly from the public side of the end closure.

12. The vented metallic end closure of claim 9, wherein a minimum distance between the upstanding dome portion and the secondary score line is at least approximately 0.010 inches and not more than approximately 0.180 inches.

13. The vented metallic end closure of claim 9, wherein the pull end of the tab comprises a downwardly projecting portion for contacting the vent opening.

14. The vented metallic end closure of claim 9, wherein a center point of the vent opening is radially offset from a center line of the end closure.

15. The vented metallic end closure of claim 9, wherein a center point of the vent opening is provided at a lateral midpoint of the end closure.

16. The vented metallic end closure of claim 9, wherein the secondary score line and vent hinge collectively comprise a flat oval shape.

17. A vented metallic end closure adapted for interconnection to a neck of a container body, comprising:

a peripheral curl;

a chuck wall extending downwardly from the peripheral curl;

a countersink interconnected to a lower end of the chuck wall;

a central panel interconnected to the countersink;

a deboss provided on the central panel;

a tab interconnected to the central panel and rotatable about a rivet;

the deboss defining an opening area comprising a dispensing opening and a vent opening;

an upstanding dome portion provided on the vent panel, the upstanding dome portion comprising a protrusion extending toward a public side of the end closure and comprising a perimeter on an upper surface of the vent panel;

the dispensing opening comprising a primary score line and the vent opening comprising a secondary score line and a vent hinge;

a secondary recess provided adjacent to and extending at least partially around the vent opening;

the tab comprising a nose end and a pull end;

wherein the pull end of the tab is adapted to contact the dome portion of the vent opening, and wherein the tab is adapted to transmit a force to the dome portion of the vent opening and sever the secondary score;

the secondary score line comprising an oval score line at least partially surrounding a vent panel;

the vent panel comprising a first dimension extending between the vent hinge and the secondary score line and a second dimension extending between opposing ends of the secondary score line, the second dimension being substantially perpendicular to the first dimension;

the first dimension comprising a distance of between approximately 0.150 and 0.170 inches; and

the second dimension comprising a distance of between approximately 0.290 and 0.360 inches.

18. The vented metallic end closure of claim 17, wherein the vent opening is radially offset from a center line of the end closure.

19. The vented metallic end closure of claim 17, wherein the secondary score line and vent hinge collectively comprise a flat oval shape.

20. The vented metallic end closure of claim 17, further comprising an anti-fracture score at least partially surrounding the secondary score line.

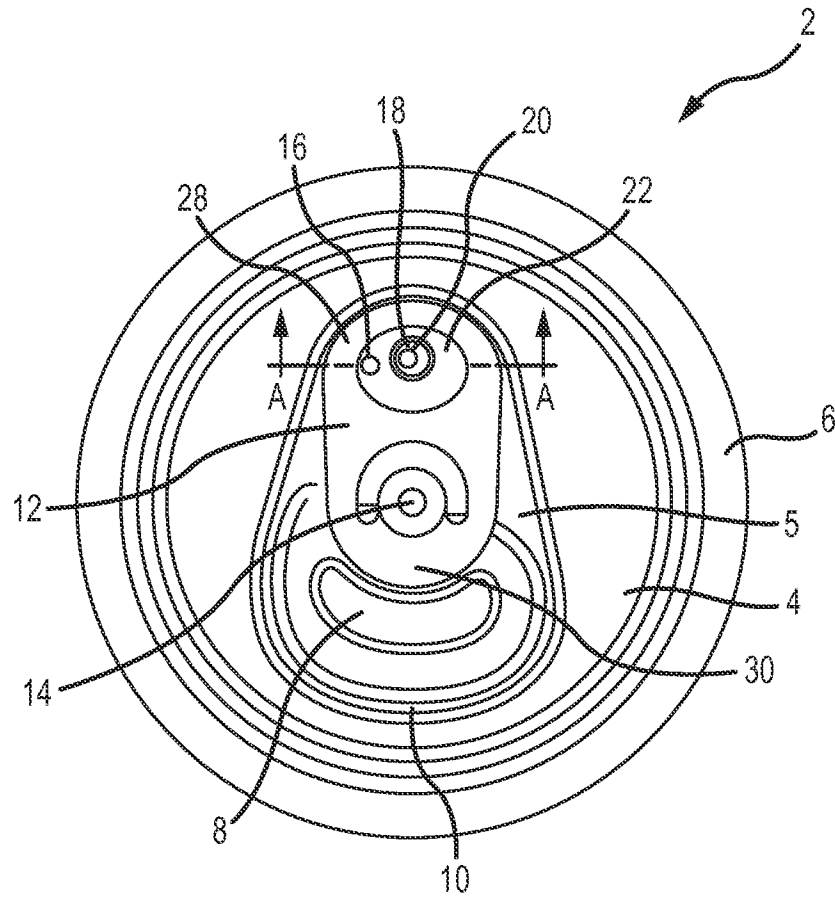

FIG. 1

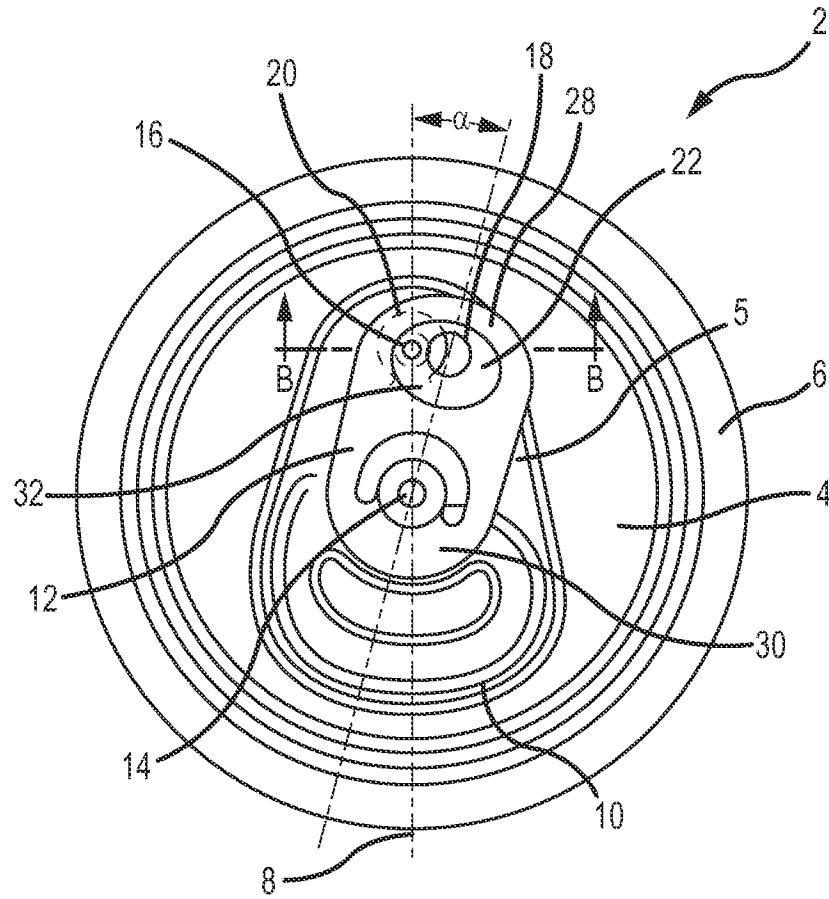

FIG. 2

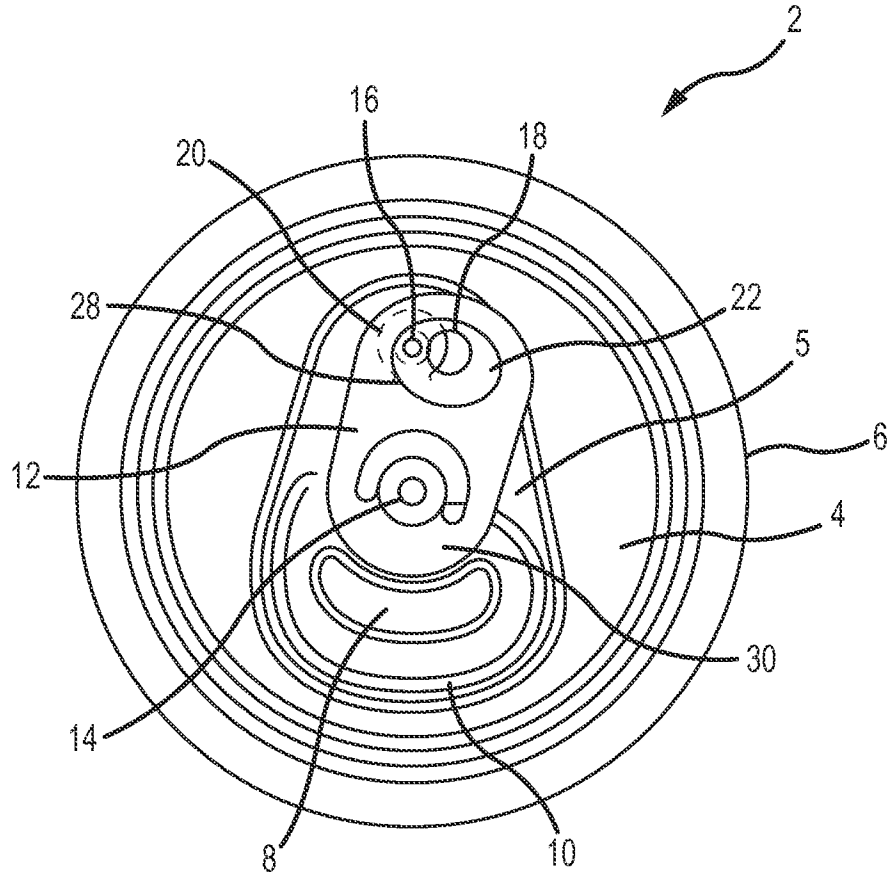
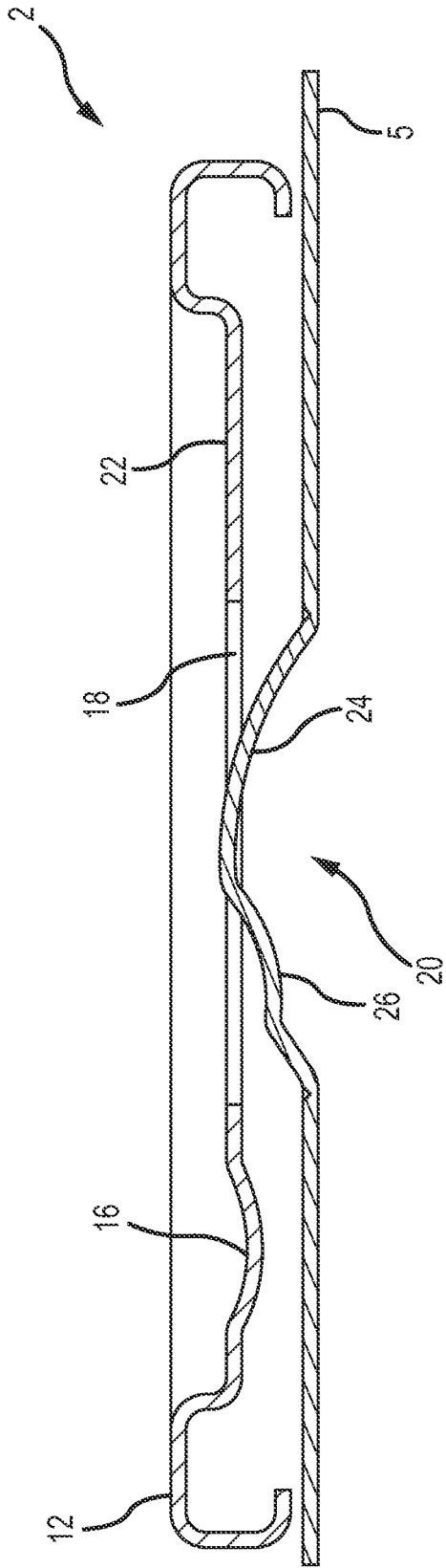

FIG.3



4/18

FIG.4

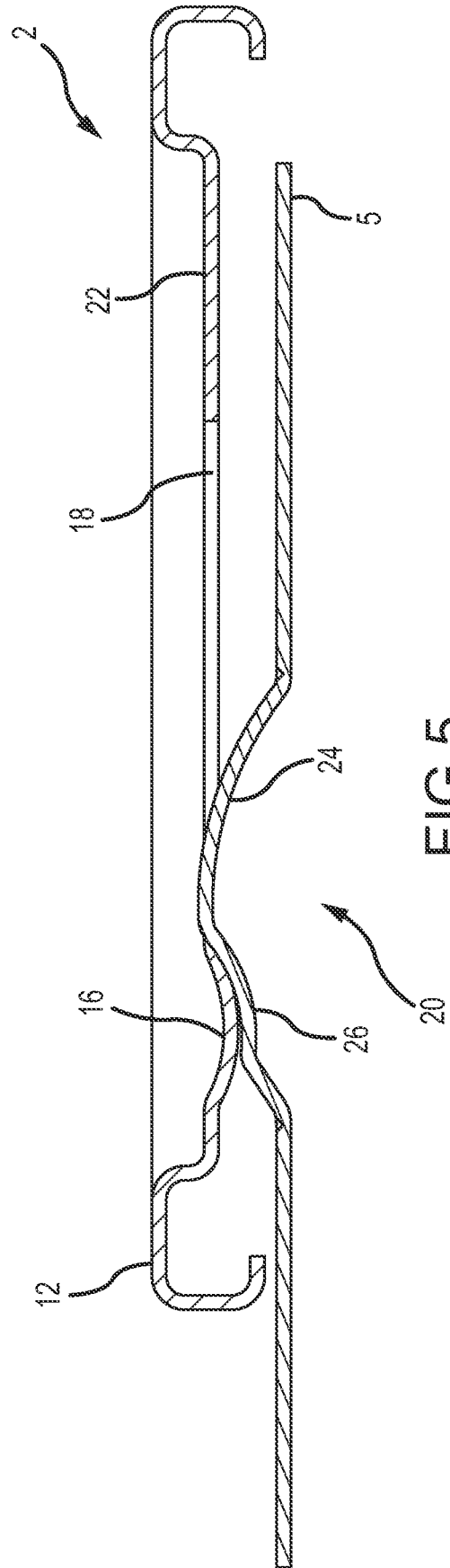

FIG.5

5/18

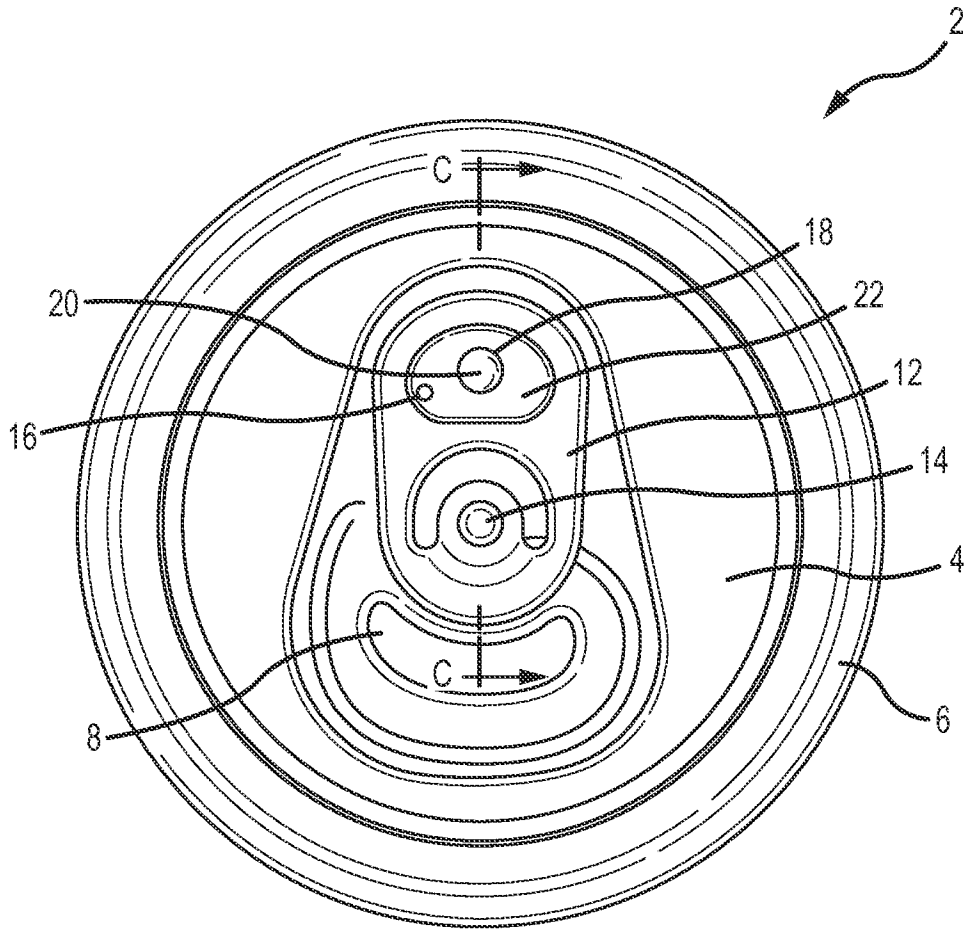

FIG. 6

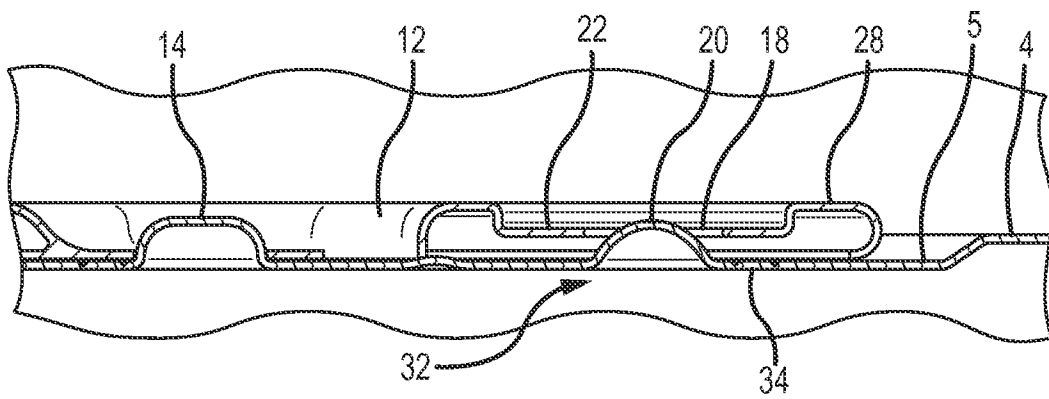

FIG. 7

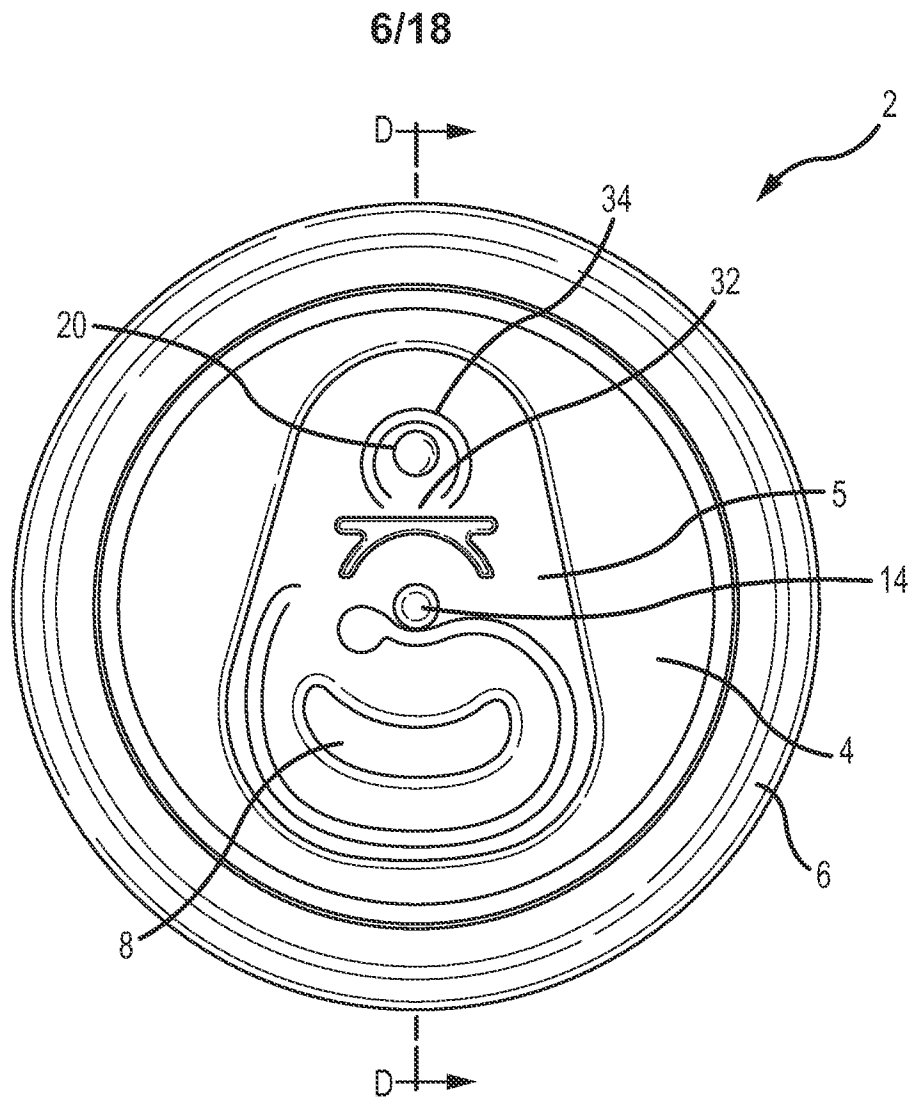

FIG. 8

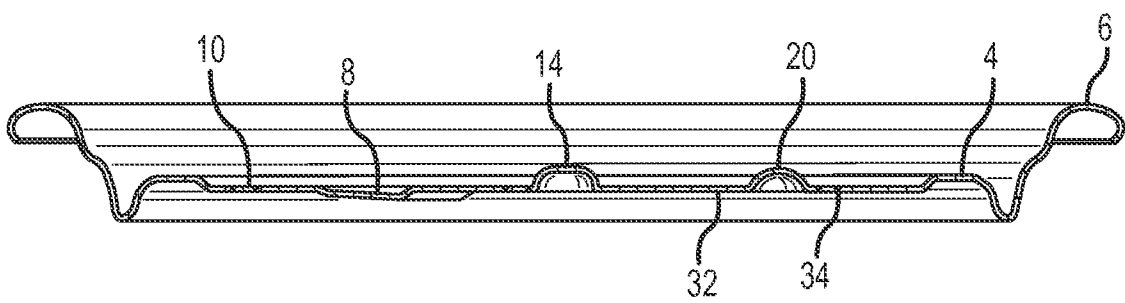

FIG. 9

7/18

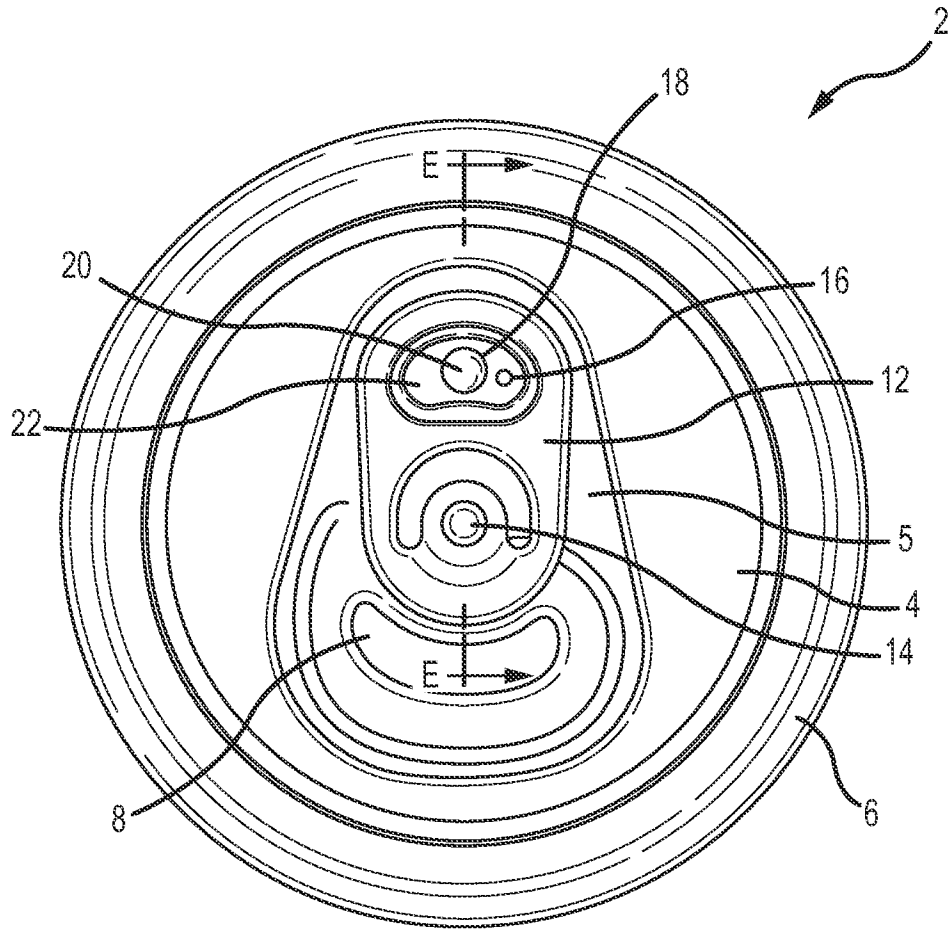

FIG. 10

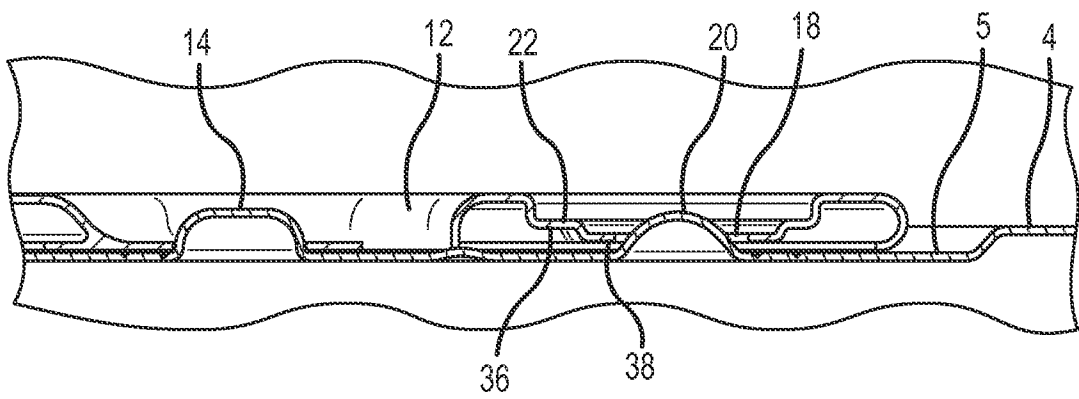

FIG. 11

8/18

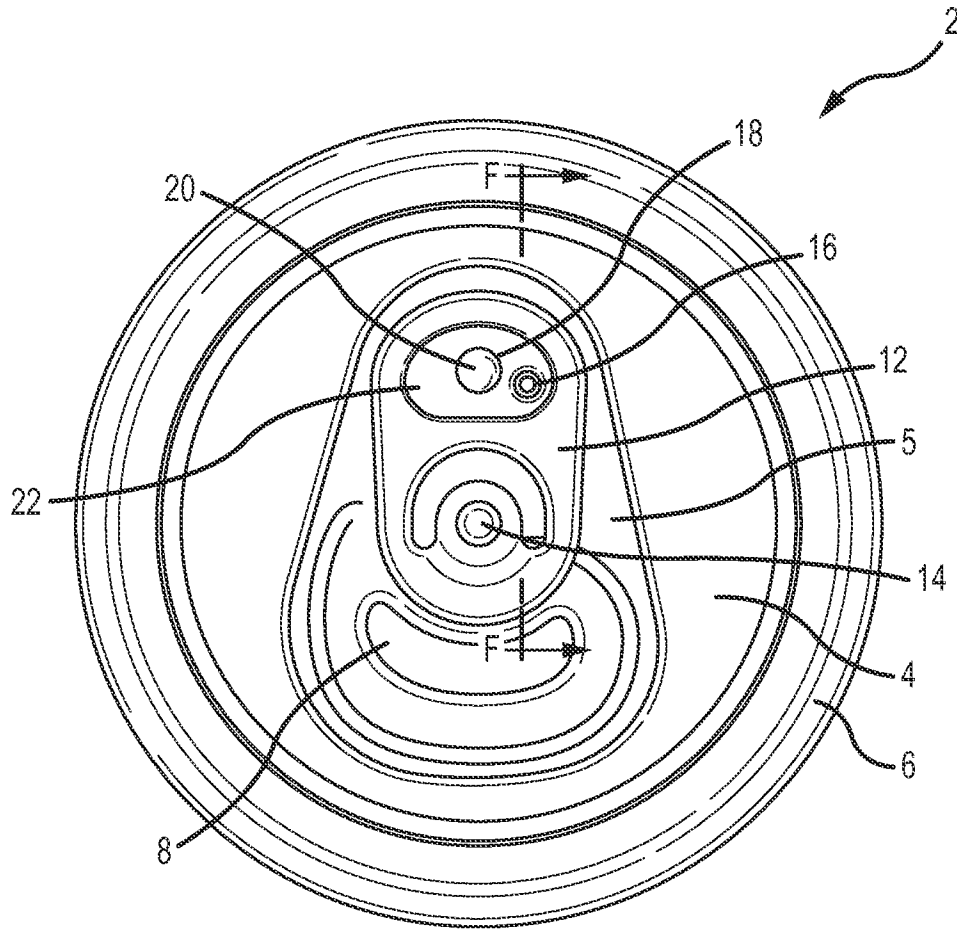

FIG. 12

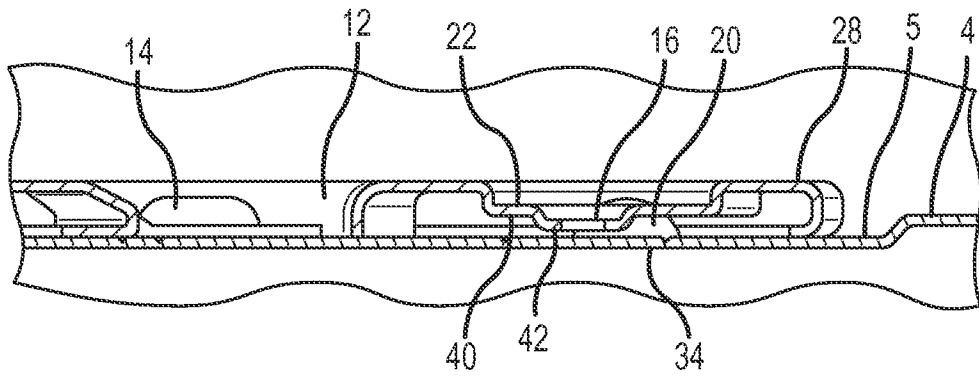

FIG. 13

9/18

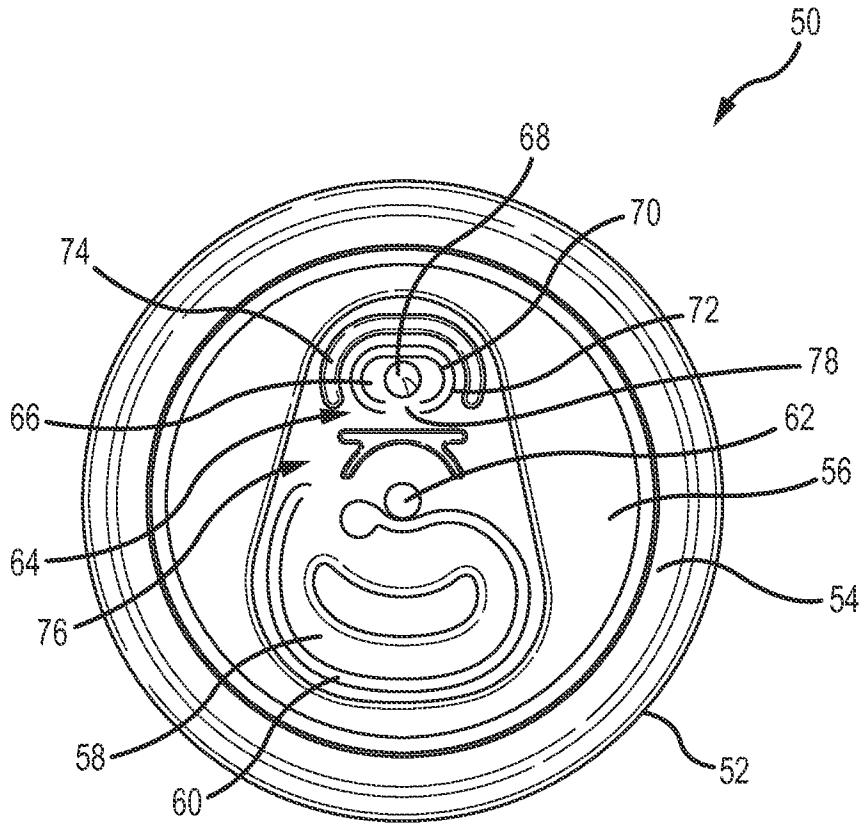

FIG. 14A

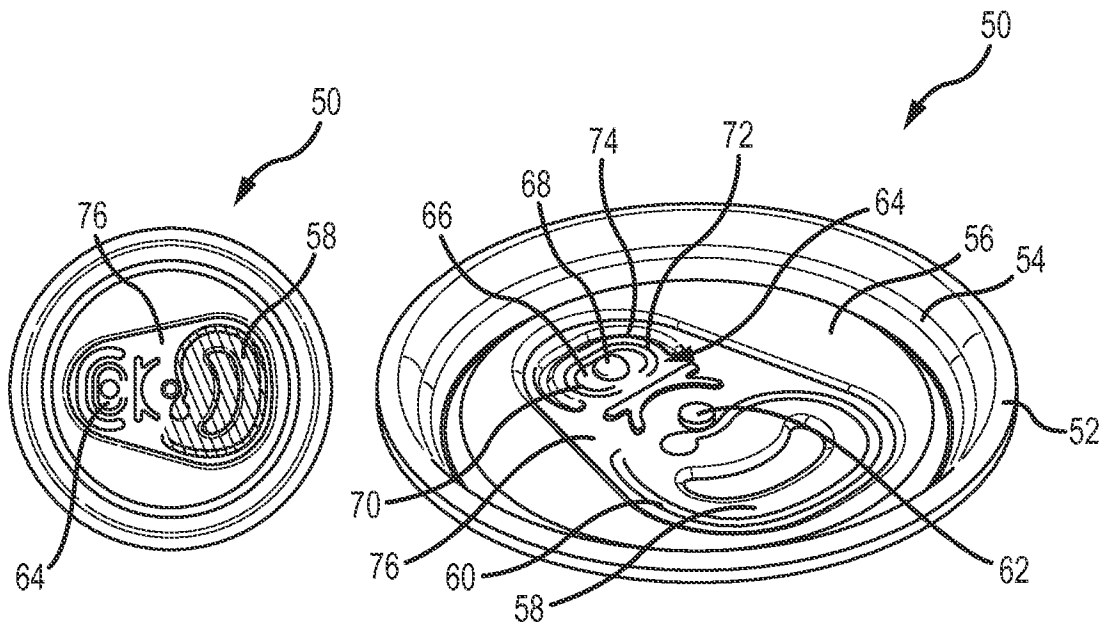

FIG. 14B

FIG. 14C

10/18

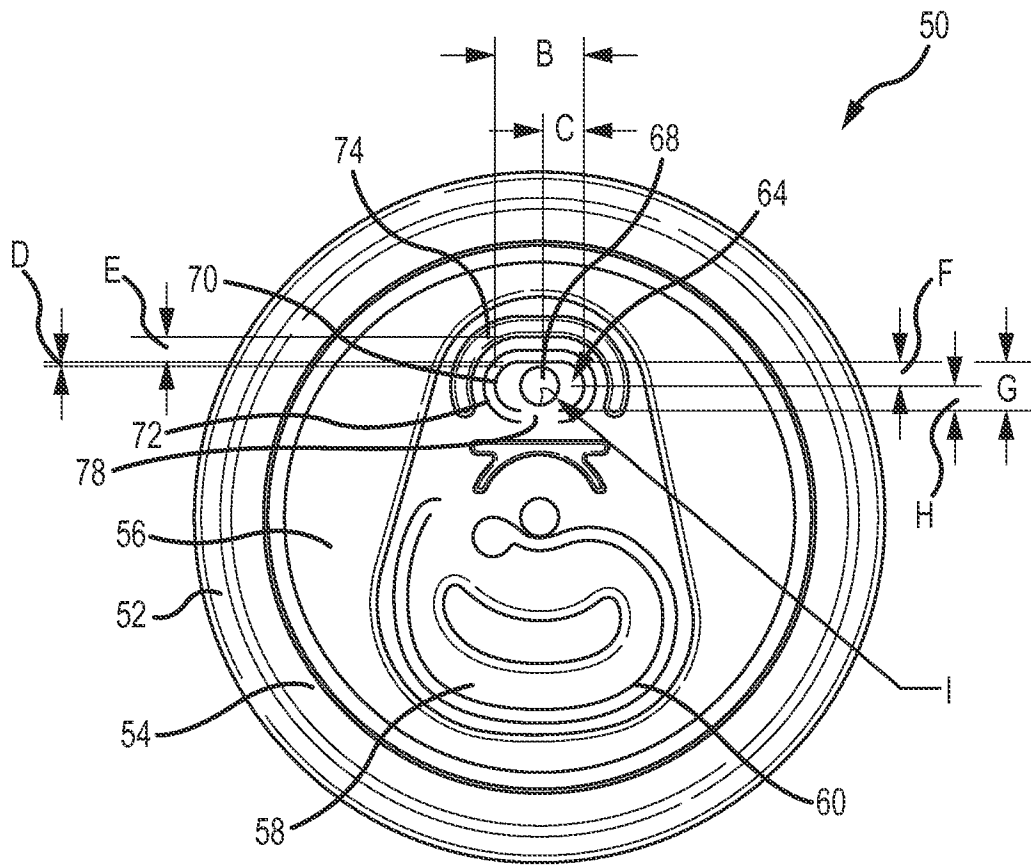

FIG. 15A

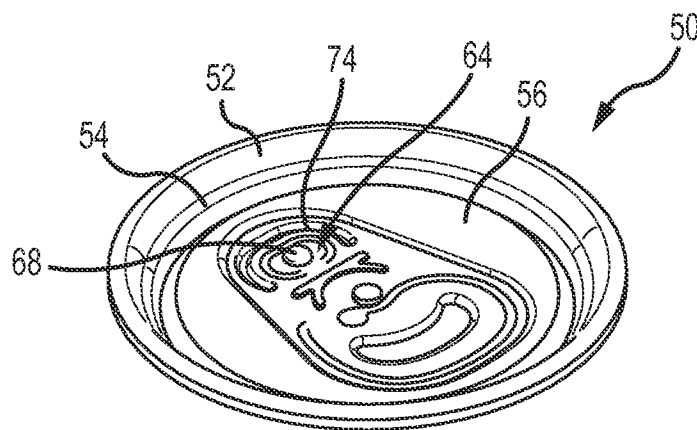

FIG. 15B

11/18

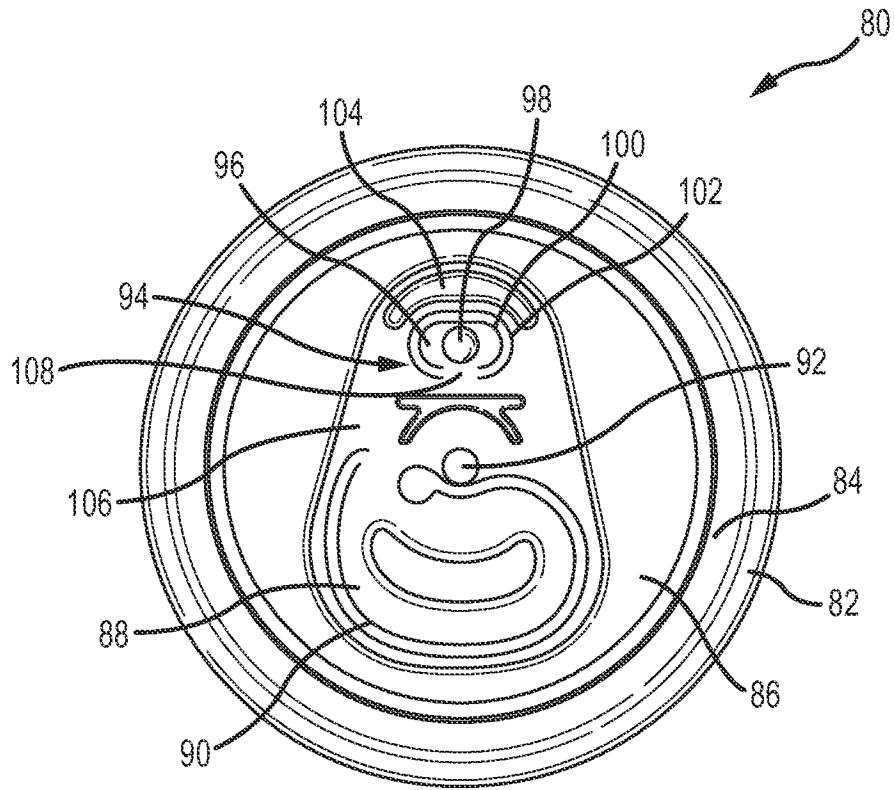

FIG. 16A

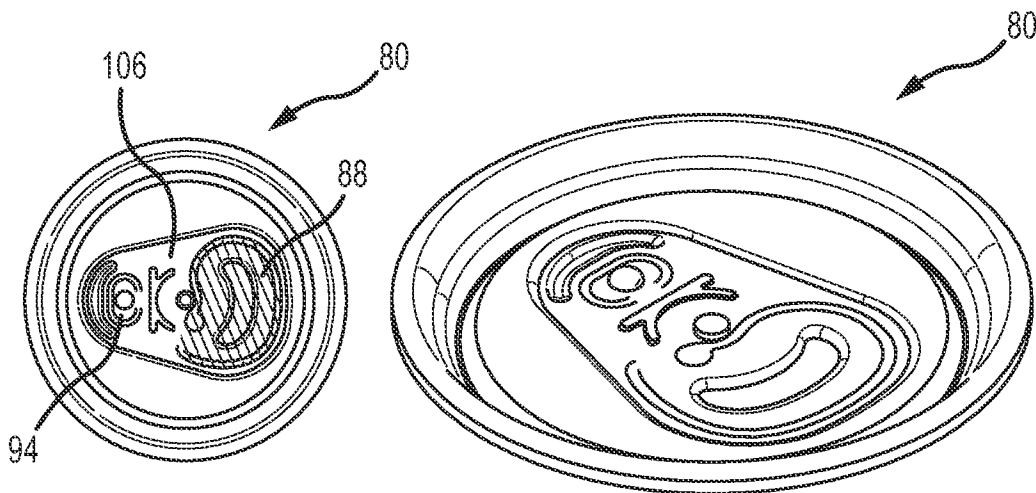

FIG. 16B

FIG. 16C

12/18

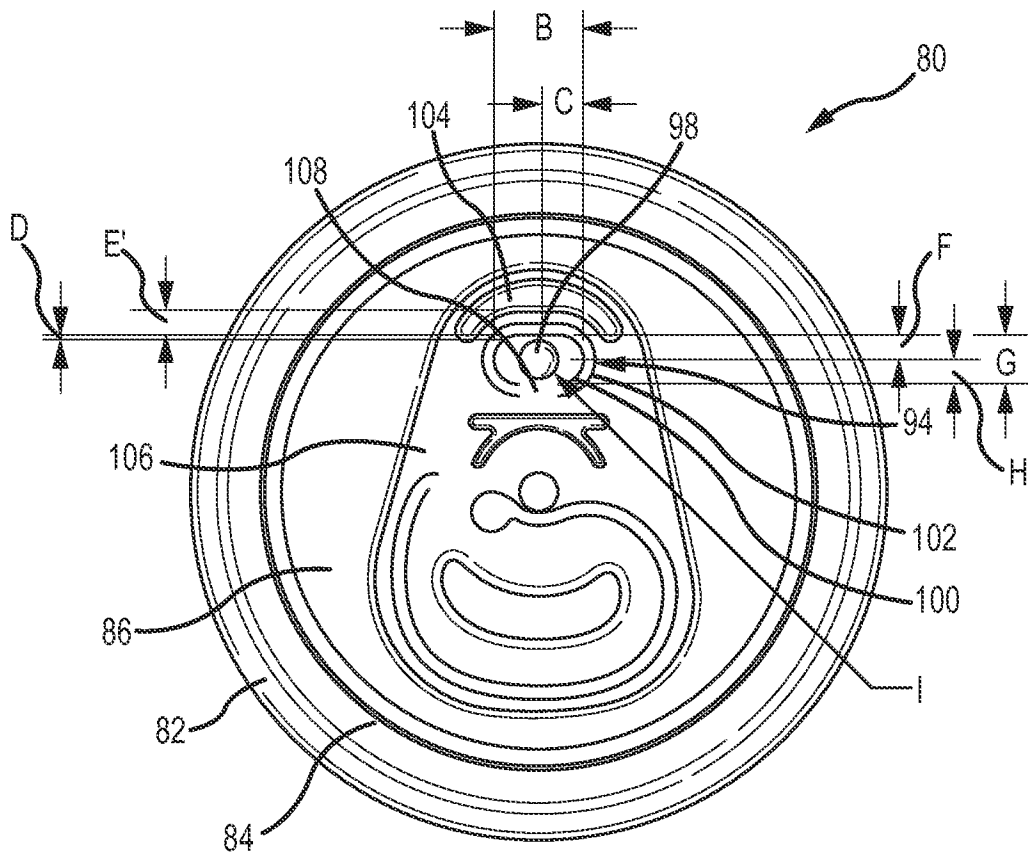

FIG. 17A

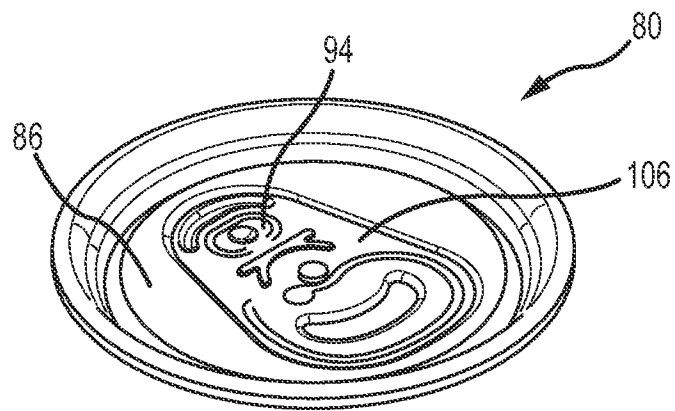

FIG. 17B

13/18

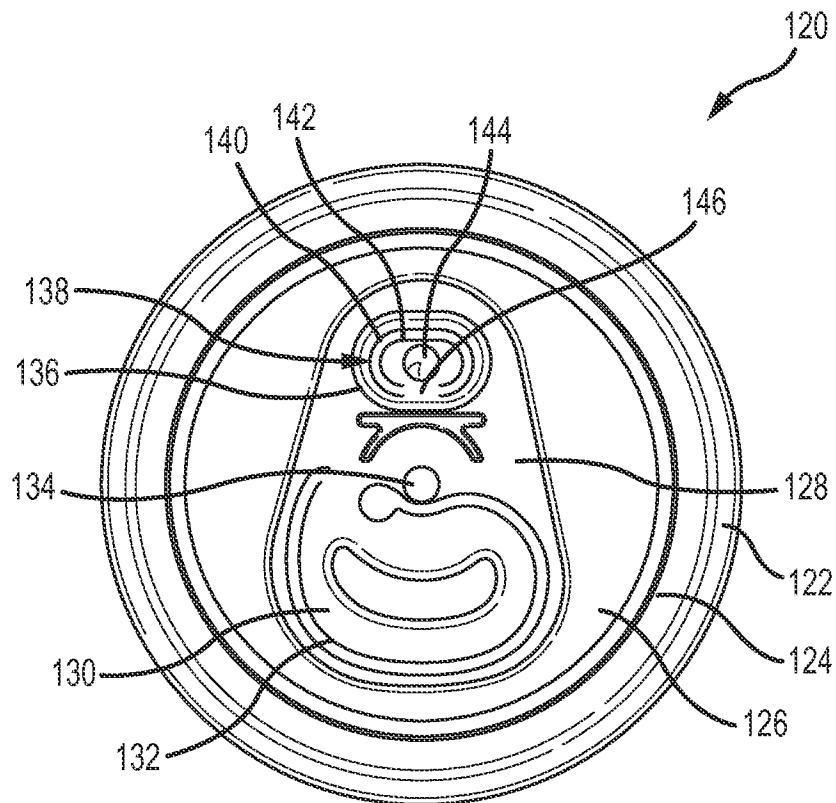

FIG. 18A

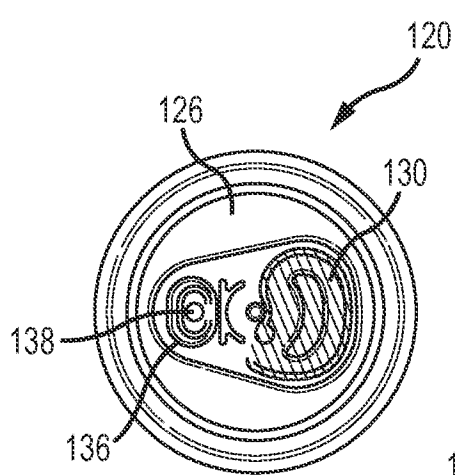

FIG. 18B

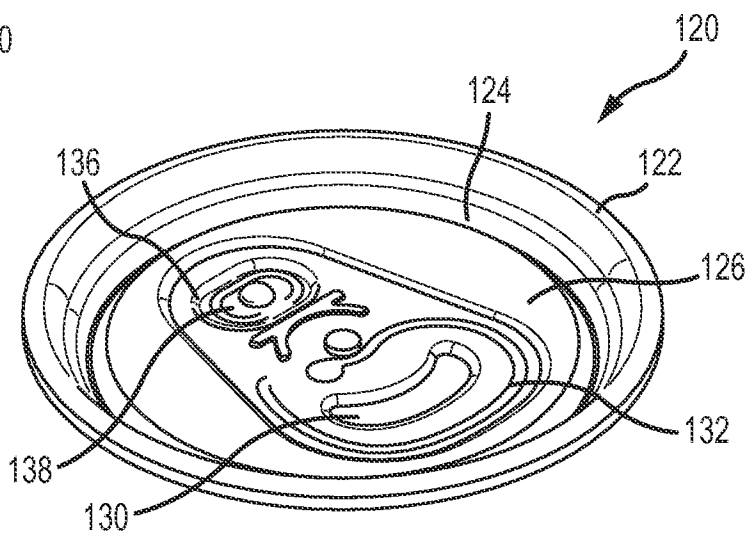

FIG. 18C

14/18

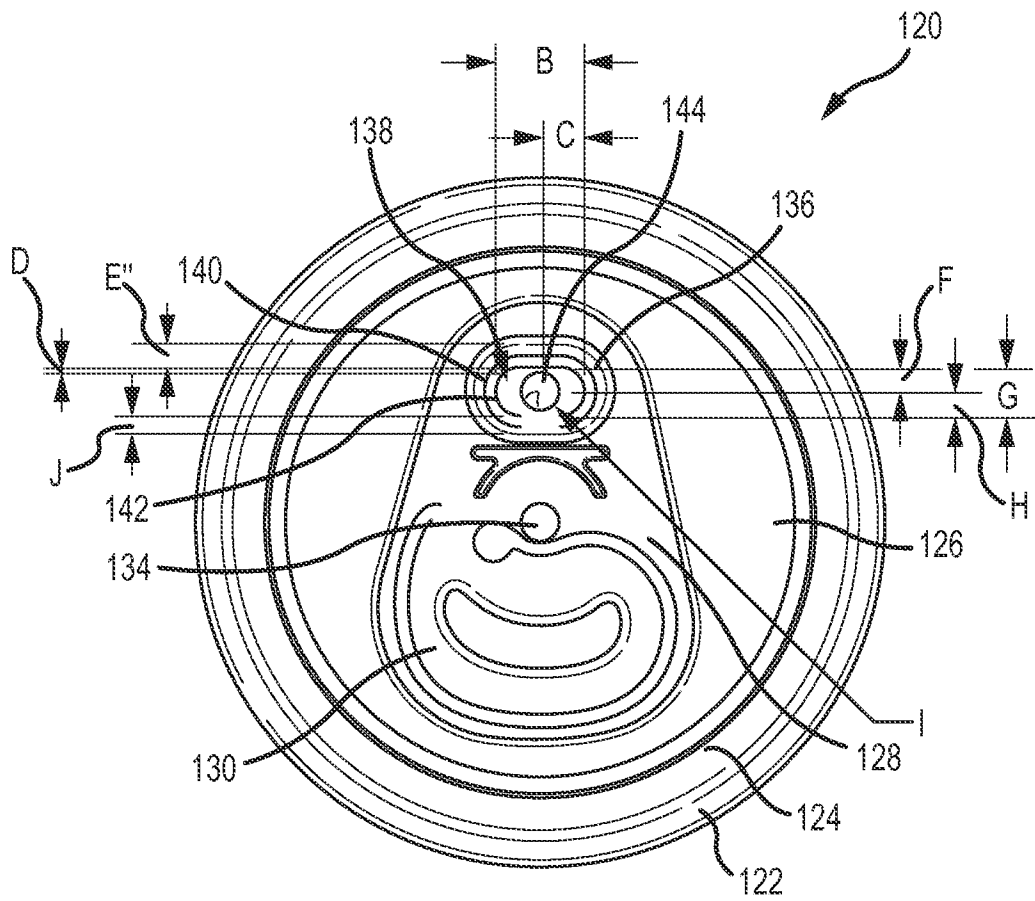

FIG. 19A

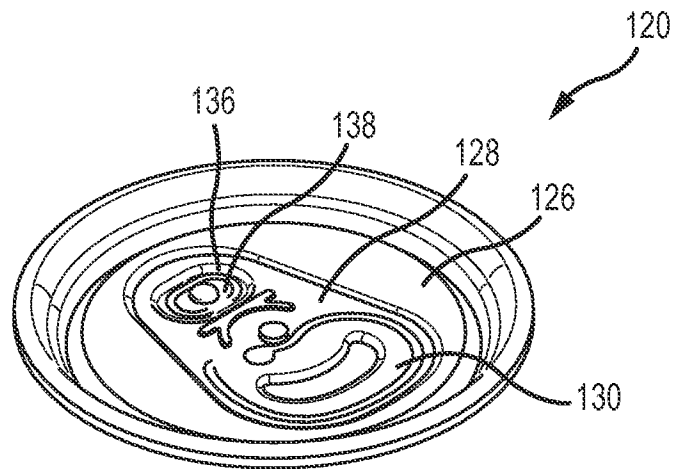

FIG. 19B

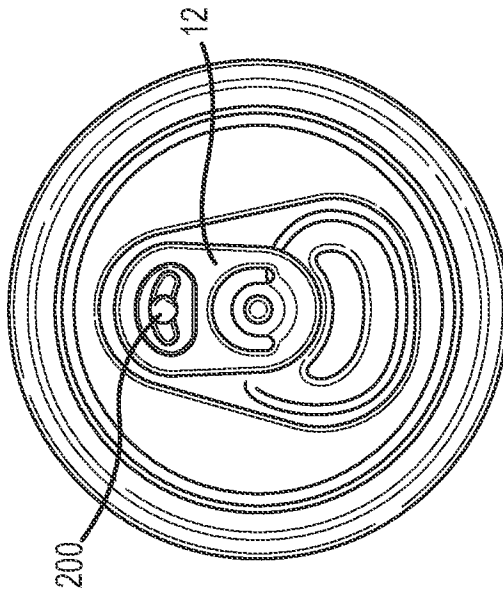

FIG.20

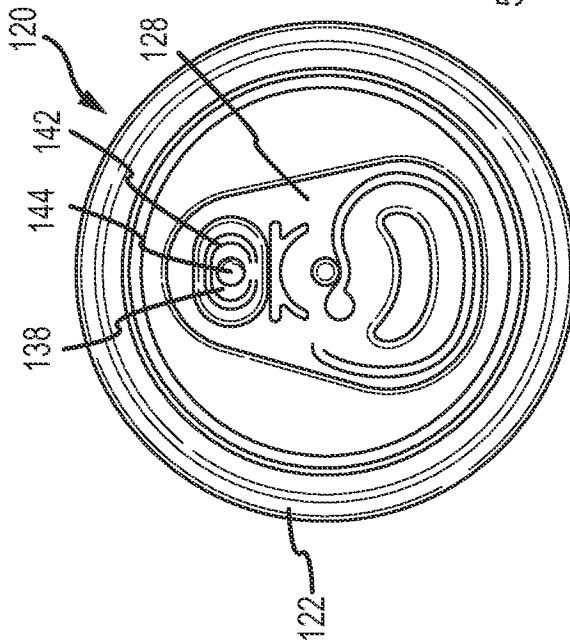

FIG.21

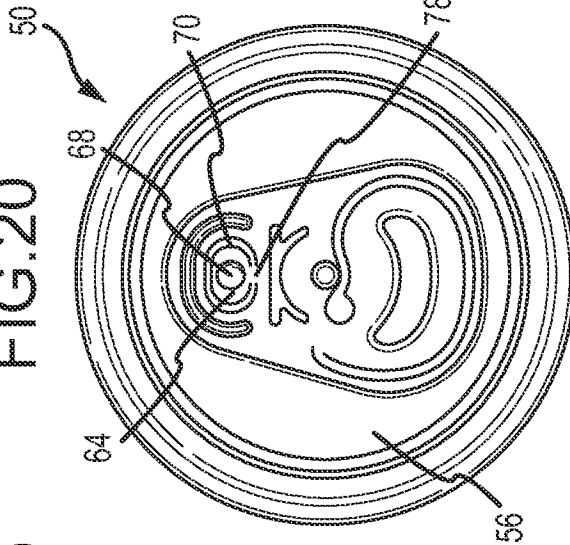

FIG.22

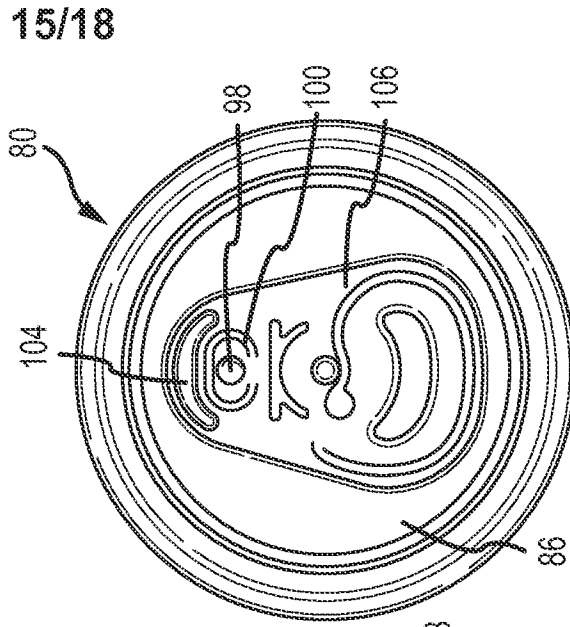

FIG.23

15/18

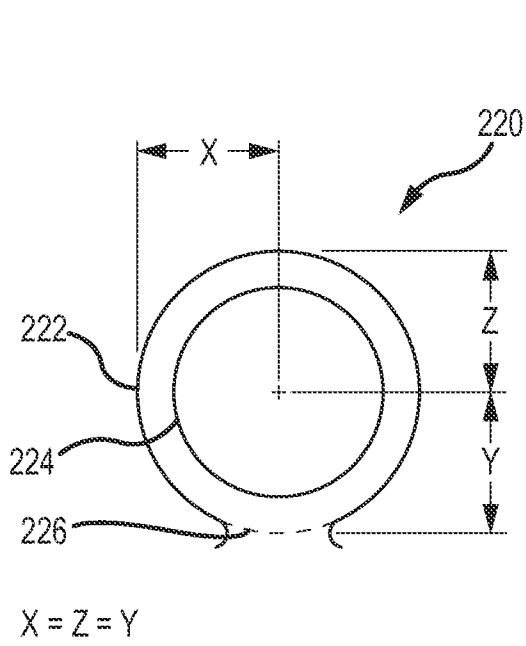

FIG.24

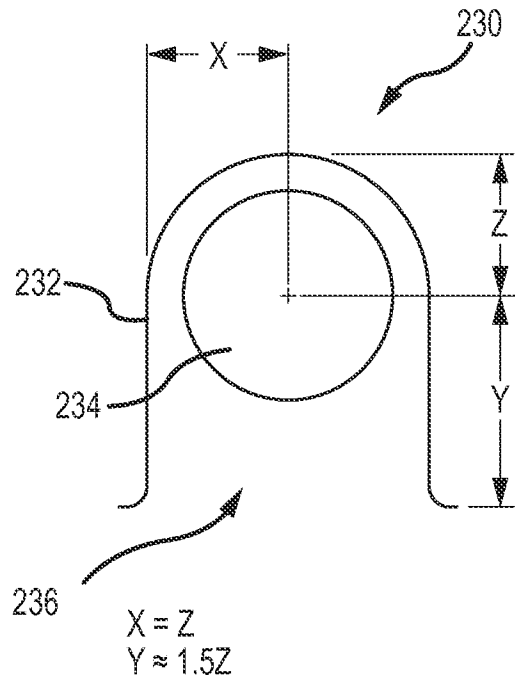

FIG.25

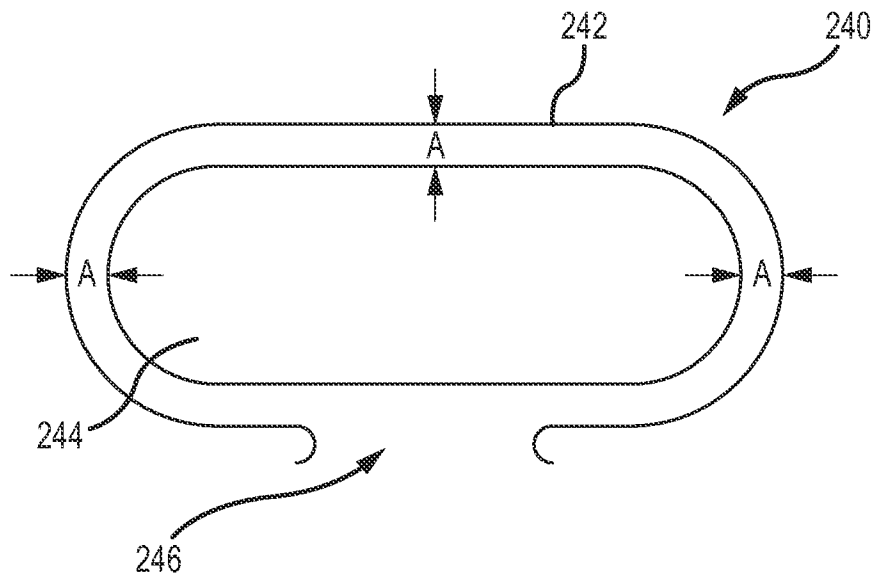

FIG.26

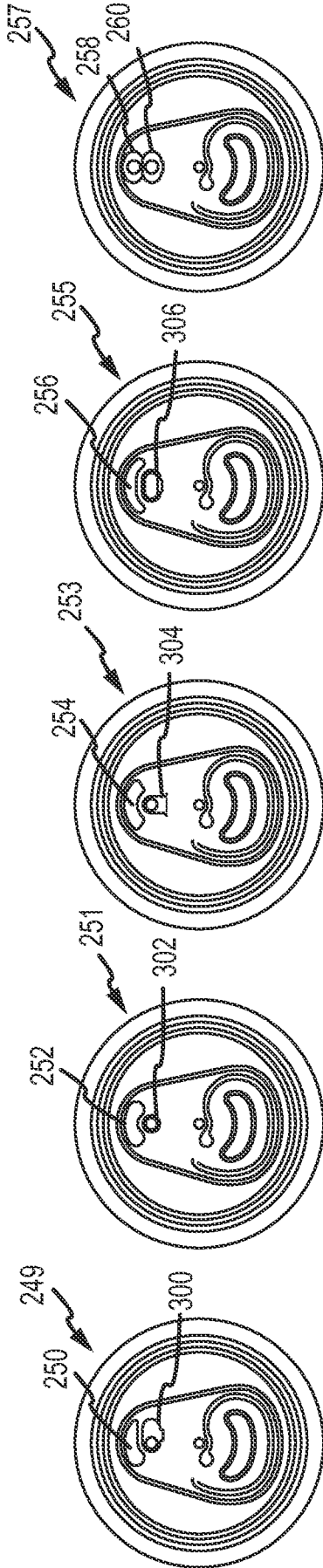

FIG.27 FIG.28 FIG.29 FIG.30 FIG.31

17/18

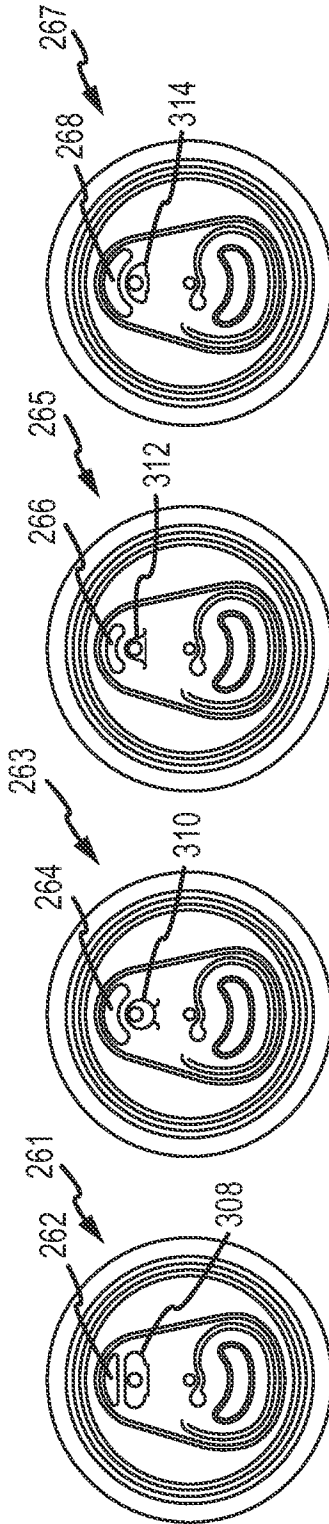

FIG.32 FIG.33 FIG.34 FIG.35

18/18

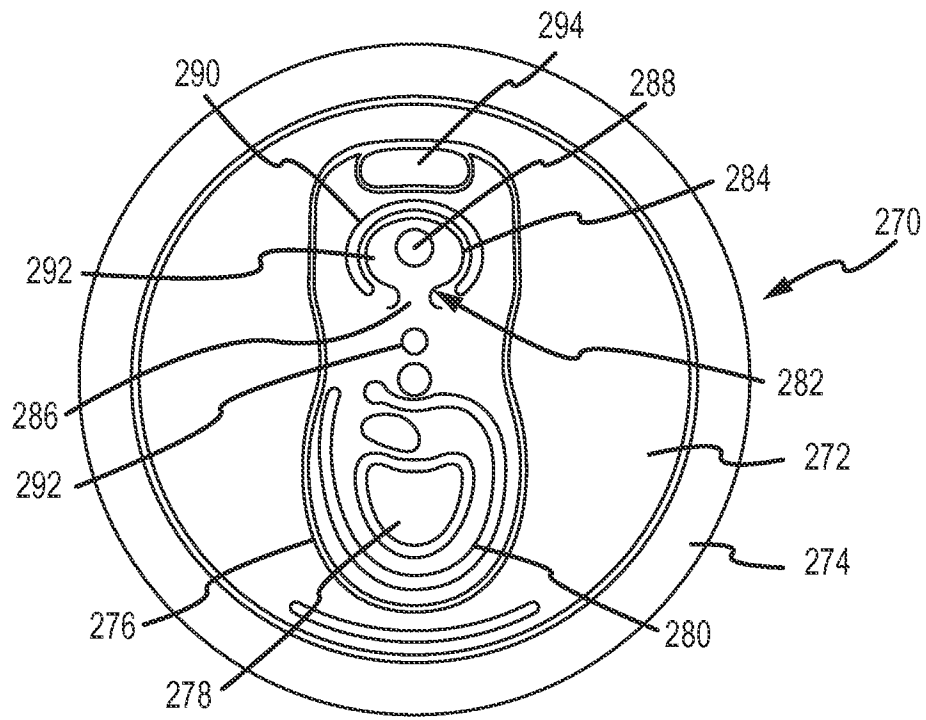

FIG. 36

INTERNATIONAL SEARCH REPORT

International application No.

PCT/US 15/42579

A. CLASSIFICATION OF SUBJECT MATTER IPC(8) - B65D 17/00 (2015.01) CPC - B21D 51/383 According to International Patent Classification (IPC) or to both national classification and IPC																						
B. FIELDS SEARCHED Minimum documentation searched (classification system followed by classification symbols) IPC(8): B65D 17/00 (2015.01) CPC: B21D 51/383 Documentation searched other than minimum documentation to the extent that such documents are included in the fields searched USPC: 220/270, 220/271. IPC(8): B65D 17/34, B65D 51/16 (2015.01). CPC: B65D 17/161, B65D 17/165, B65D 17/24, B65D 2205/02, B65D 2517/0014, B65D 2517/0062, B65D 2517/0082, B65D 2517/0092, B65D 2517/0094, B65D 41/32, B65D 47/106 Electronic data base consulted during the international search (name of data base and, where practicable, search terms used) PatBase, Google (Patents, Books, Scholar). Search terms: ALUMINUM, APERTURE, AUXILIARY, BEFORE, BEVERAGE, CAN, CANISTER, CONTAINER, END, FASTER, FOOD, GASOLINE, GLUG, GRANT, HOLE, JUICE, KEROSENE, LID, LIQUID, MEAT, METAL, OFFICE, OIL, PATENT, POUR, Poured, Pouring, PRIORITY, RAQUETBALL, RELEASE, RIVET, SCORE, SECOND																						
C. DOCUMENTS CONSIDERED TO BE RELEVANT																						
<table border="1"> <thead> <tr> <th>Category*</th> <th>Citation of document, with indication, where appropriate, of the relevant passages</th> <th>Relevant to claim No.</th> </tr> </thead> <tbody> <tr> <td>X</td> <td>US 2013/0118133 A1 (JACOBBER et al.) 16 May 2013 (16.05.2013), entire document, especially figs 2, 3a-b, 4b, 5, 6a-d, 10a-b, 11a, 16b, paras [0002], [0018], [0071].</td> <td>1-20</td> </tr> <tr> <td>A</td> <td>US 2014/0263333 A1 (KEANE et al.) 18 September 2014 (18.09.2014), entire document, especially figs 1-6, 9-11, fig 13a, paras [0071], [0074], [0082]</td> <td>1-20</td> </tr> <tr> <td>A</td> <td>US 5,011,037 A (MOEN et al.) 30 April 1991 (30.04.1991), entire document, especially figs 1, 3-6, 9 col 3 ln 1, 42</td> <td>1-20</td> </tr> <tr> <td>A</td> <td>US 3,741,432 A (PEARCE et al.) 26 June 1973 (26.06.1973), entire document</td> <td>1-20</td> </tr> <tr> <td>A</td> <td>US 8,397,935 B2 (EMANUELE) 19 March 2009 (19.03.2009), entire document</td> <td>1-20</td> </tr> <tr> <td>A</td> <td>US 2010/0294771 A1 (HOLDER) 25 November 2010 (25.11.2010), entire document</td> <td>1-20</td> </tr> </tbody> </table>	Category*	Citation of document, with indication, where appropriate, of the relevant passages	Relevant to claim No.	X	US 2013/0118133 A1 (JACOBBER et al.) 16 May 2013 (16.05.2013), entire document, especially figs 2, 3a-b, 4b, 5, 6a-d, 10a-b, 11a, 16b, paras [0002], [0018], [0071].	1-20	A	US 2014/0263333 A1 (KEANE et al.) 18 September 2014 (18.09.2014), entire document, especially figs 1-6, 9-11, fig 13a, paras [0071], [0074], [0082]	1-20	A	US 5,011,037 A (MOEN et al.) 30 April 1991 (30.04.1991), entire document, especially figs 1, 3-6, 9 col 3 ln 1, 42	1-20	A	US 3,741,432 A (PEARCE et al.) 26 June 1973 (26.06.1973), entire document	1-20	A	US 8,397,935 B2 (EMANUELE) 19 March 2009 (19.03.2009), entire document	1-20	A	US 2010/0294771 A1 (HOLDER) 25 November 2010 (25.11.2010), entire document	1-20	
Category*	Citation of document, with indication, where appropriate, of the relevant passages	Relevant to claim No.																				
X	US 2013/0118133 A1 (JACOBBER et al.) 16 May 2013 (16.05.2013), entire document, especially figs 2, 3a-b, 4b, 5, 6a-d, 10a-b, 11a, 16b, paras [0002], [0018], [0071].	1-20																				
A	US 2014/0263333 A1 (KEANE et al.) 18 September 2014 (18.09.2014), entire document, especially figs 1-6, 9-11, fig 13a, paras [0071], [0074], [0082]	1-20																				
A	US 5,011,037 A (MOEN et al.) 30 April 1991 (30.04.1991), entire document, especially figs 1, 3-6, 9 col 3 ln 1, 42	1-20																				
A	US 3,741,432 A (PEARCE et al.) 26 June 1973 (26.06.1973), entire document	1-20																				
A	US 8,397,935 B2 (EMANUELE) 19 March 2009 (19.03.2009), entire document	1-20																				
A	US 2010/0294771 A1 (HOLDER) 25 November 2010 (25.11.2010), entire document	1-20																				
<input type="checkbox"/> Further documents are listed in the continuation of Box C. <input type="checkbox"/>																						
<table border="0"> <tr> <td>* Special categories of cited documents:</td> <td>"T" later document published after the international filing date or priority date and not in conflict with the application but cited to understand the principle or theory underlying the invention</td> </tr> <tr> <td>"A" document defining the general state of the art which is not considered to be of particular relevance</td> <td>"X" document of particular relevance; the claimed invention cannot be considered novel or cannot be considered to involve an inventive step when the document is taken alone</td> </tr> <tr> <td>"E" earlier application or patent but published on or after the international filing date</td> <td>"Y" document of particular relevance; the claimed invention cannot be considered to involve an inventive step when the document is combined with one or more other such documents, such combination being obvious to a person skilled in the art</td> </tr> <tr> <td>"L" document which may throw doubts on priority claim(s) or which is cited to establish the publication date of another citation or other special reason (as specified)</td> <td>"&" document member of the same patent family</td> </tr> <tr> <td>"O" document referring to an oral disclosure, use, exhibition or other means</td> <td></td> </tr> <tr> <td>"P" document published prior to the international filing date but later than the priority date claimed</td> <td></td> </tr> </table>		* Special categories of cited documents:	"T" later document published after the international filing date or priority date and not in conflict with the application but cited to understand the principle or theory underlying the invention	"A" document defining the general state of the art which is not considered to be of particular relevance	"X" document of particular relevance; the claimed invention cannot be considered novel or cannot be considered to involve an inventive step when the document is taken alone	"E" earlier application or patent but published on or after the international filing date	"Y" document of particular relevance; the claimed invention cannot be considered to involve an inventive step when the document is combined with one or more other such documents, such combination being obvious to a person skilled in the art	"L" document which may throw doubts on priority claim(s) or which is cited to establish the publication date of another citation or other special reason (as specified)	"&" document member of the same patent family	"O" document referring to an oral disclosure, use, exhibition or other means		"P" document published prior to the international filing date but later than the priority date claimed										
* Special categories of cited documents:	"T" later document published after the international filing date or priority date and not in conflict with the application but cited to understand the principle or theory underlying the invention																					
"A" document defining the general state of the art which is not considered to be of particular relevance	"X" document of particular relevance; the claimed invention cannot be considered novel or cannot be considered to involve an inventive step when the document is taken alone																					
"E" earlier application or patent but published on or after the international filing date	"Y" document of particular relevance; the claimed invention cannot be considered to involve an inventive step when the document is combined with one or more other such documents, such combination being obvious to a person skilled in the art																					
"L" document which may throw doubts on priority claim(s) or which is cited to establish the publication date of another citation or other special reason (as specified)	"&" document member of the same patent family																					
"O" document referring to an oral disclosure, use, exhibition or other means																						
"P" document published prior to the international filing date but later than the priority date claimed																						
Date of the actual completion of the international search 17 September 2015 (17.09.2015)	Date of mailing of the international search report 28 OCT 2015																					
Name and mailing address of the ISA/US Mail Stop PCT, Attn: ISA/US, Commissioner for Patents P.O. Box 1450, Alexandria, Virginia 22313-1450 Facsimile No. 571-273-8300	Authorized officer: Lee W. Young PCT Helpdesk: 571-272-4300 PCT OSP: 571-272-7774																					