



- (51) **International Patent Classification:**
A42B 1/24 (2006.01) *A42B 1/18* (2006.01)
- (21) **International Application Number:**
PCT/US2013/069220
- (22) **International Filing Date:**
8 November 2013 (08.11.2013)
- (25) **Filing Language:** English
- (26) **Publication Language:** English
- (30) **Priority Data:**
13/690,881 30 November 2012 (30.11.2012) US
- (71) **Applicant:** VIZERS GROUP, LLC [US/US]; 8040 W. Highway 326, Ocala, FL 34482 (US).
- (72) **Inventor; and**
- (71) **Applicant :** JOHNS, Stephen [US/US]; 783 Killamey Court, Merritt Island, FL 32953 (US).
- (74) **Agent:** STEINBERGER, Brian S.; 101 Brevard Avenue, Cocoa, FL 32922 (US).
- (81) **Designated States** (unless otherwise indicated, for every kind of national protection available): AE, AG, AL, AM, AO, AT, AU, AZ, BA, BB, BG, BH, BN, BR, BW, BY,

BZ, CA, CH, CL, CN, CO, CR, CU, CZ, DE, DK, DM, DO, DZ, EC, EE, EG, ES, FI, GB, GD, GE, GH, GM, GT, HN, HR, HU, ID, IL, IN, IR, IS, JP, KE, KG, KN, KP, KR, KZ, LA, LC, LK, LR, LS, LT, LU, LY, MA, MD, ME, MG, MK, MN, MW, MX, MY, MZ, NA, NG, NI, NO, NZ, OM, PA, PE, PG, PH, PL, PT, QA, RO, RS, RU, RW, SA, SC, SD, SE, SG, SK, SL, SM, ST, SV, SY, TH, TJ, TM, TN, TR, TT, TZ, UA, UG, US, UZ, VC, VN, ZA, ZM, ZW.

- (84) **Designated States** (unless otherwise indicated, for every kind of regional protection available): ARIPO (BW, GH, GM, KE, LR, LS, MW, MZ, NA, RW, SD, SL, SZ, TZ, UG, ZM, ZW), Eurasian (AM, AZ, BY, KG, KZ, RU, TJ, TM), European (AL, AT, BE, BG, CH, CY, CZ, DE, DK, EE, ES, FI, FR, GB, GR, HR, HU, IE, IS, IT, LT, LU, LV, MC, MK, MT, NL, NO, PL, PT, RO, RS, SE, SI, SK, SM, TR), OAPI (BF, BJ, CF, CG, CI, CM, GA, GN, GQ, GW, KM, ML, MR, NE, SN, TD, TG).

Published:

- with international search report (Art. 21(3))
- with amended claims (Art. 19(1))



WO 2014/085061 A1

(54) **Title:** VISOR WITH PLUG IN ACCESSORY SOCKETS

(57) **Abstract:** Visor assemblies, apparatus, and methods of using a soft type foam visor formed from a pliable and flexible material, such as but not limited to EVA(ethylene vinyl acetate), having patterns of through-hole and partial cutouts hole that allow for accessories such as labels, charms, badges, and the like, to be plugged into the openings and easily removable and interchangeable with other accessories. The visor assemblies can include a removable rear head strap having a plurality of holes with rivets that allow the strap to adjust about different head sizes. A puncture tool can be used to turn a partial cutout into a complete throughhole cutout. The puncture tool can be mounted into a cutout hole. An adapter mounted to cutout holes can support sunglasses/eyeglasses.

VISOR WITH PLUG IN ACCESSORY SOCKETS

This invention claims the benefit of priority to U.S. Patent Application Serial No. 13/690,881 filed November 30, 2012, which is incorporated by reference in its' entirety.

5

FIELD OF INVENTION

This invention relates to hats and caps, in particular to head visor assemblies, apparatus, and methods of using a soft type foam visor having patterns of different shaped hole openings, such as but not limited to geometrical shapes, letters, characters, and the like, that allow for accessories such as labels, charms, badges, sunglasses, and the like, to be plugged into the openings and easily removable and interchangeable with other accessories.

10

BACKGROUND AND PRIOR ART

Sun visors have become a popular type of headgear for keeping the sun off the face of the wearer. Often the visors are formed from a cloth or fabric type material with a fixed band. Other types of well known visors are formed from a hard plastic with rearwardly extending curved bands which wrap about part of the head of the wearer.

15

A problem with these prior art visors is that indicia (such as but not limited to advertisements, etc.) must be permanently fixed thereon. For example, sewing a label on a cloth or fabric visor is well known, but the label is not easily removable.

20

Painting indicia with markers and the like, can also be done on prior art visors, but the paint is also generally permanent. Peel and stick decals can also be used, but they are also intended to be permanent and are not intended to be easily removed or changed.

25

Using a hook and loop fastener, such as Velcro ®, can also be used, but at least one side of the hook and loop fastener, must also be permanently attached to a surface of the visor.

Caps and visors have been made over the years with holes. See for example, U.S. Patents: 1,782,206 to Kornsweet; D460,604 to Sullivan; D601,329 to Johns, the latter being the inventor of the subject invention. However, the holes were used for ventilation and/or decoration, and were not useful for mounting and supporting indicia thereon.

5 Thus, the need exists for solutions to the above problems with the prior art.

SUMMARY OF THE INVENTION

A primary objective of the present invention is to provide head visor devices,
10 apparatus, and methods of using a soft type foam visor having patterns of partial and/or full cutout hole openings that allow for accessories such as labels, charms, badges, and the like, to be plugged into the openings and easily removable and interchangeable with other accessories.

A secondary objective of the present invention is to provide head visor devices,
15 apparatus, and methods of using a soft type foam visor having patterns of partial and/or full cutout hole openings that allow for accessories such as labels, charms, badges, and the like, to be easily removable and interchangeable with other accessories.

A third objective of the present invention is to provide head visor devices,
apparatus, and methods of using a soft type foam visor having patterns of partial and/or
20 complete throughhole openings that allow for accessories, having an adjustable head strap that is also removable.

A fourth objective of the present invention is to provide head visor devices,
apparatus, and methods of using a soft type foam visor having patterns of partial and/or
complete throughhole openings with a puncture tool that can turn partial cutouts into
25 throughhole cutouts to mount accessories thereon.

A fifth objective of the present invention is to provide head visor devices,
apparatus, and methods of using a soft type foam visor having patterns of partial and/or

complete throughhole openings having different shapes, such as but not limited to different geometrical shapes, letter shapes, character shapes, and the like, in order to mount accessories thereon.

A sixth objective of the present invention is to provide head visor devices,
5 apparatus, and methods of using a soft type foam visor having patterns of partial and/or complete throughhole openings that allow for accessories such as adapters to be able to mount sunglasses/eyeglasses to the visor.

A visor assembly, can include a visor with headband formed from a flexible and pliable material, a plurality of slot shapes on a front surface portion of the visor with
10 headband, at least one accessory having a male member that mateably attaches into at least one of the slots, wherein the accessory is both attachable and detachable from the visor with headband.

The visor assembly of claim 1, can include a removable strap having ends that are attachable to left and right portions of the headband, the removable strap being formed
15 from the flexible and pliable material. The removable strap can include rivet members having inwardly protruding portions for being insertable into a plurality of adjustment holes in the removable strap. The visor material can be EVA(ethylene vinyl acetate).

The accessory can include a logo plate, having indicia across a front surface of the logo plate, and/or a decorative charm.

20 The slot shapes can include circular shapes, noncircular geometrical shapes, outline shapes of different characters and objects.

The slot shapes can include through-hole cutouts through the visor, and/or partial cutouts through only a surface portion of the visor.

A puncture tool can be included for puncturing a partial-cutout into a through-hole
25 cutout. An adapter can be used for attaching sunglasses/eyeglasses to the visor assembly.

A visor assembly kit, can include the combination of a visor with headband formed from a flexible and pliable material, a plurality of both through-hole slots and

partial cut-out slots along a front surface portion of the visor with headband, a removable strap having ends that are attachable to left and right portions of the headband, the removable strap being formed from the flexible and pliable material, and a plurality of accessories, each accessory having a male member that mateably attaches into at least one
5 of the through-hole slots and partial cut-out slots, wherein the accessories are both attachable and detachable from the visor with headband, and wherein the accessories are selected from the group consisting of logo plates and decorative charms and a puncture tool to punch out a partial cutout, and an adapter for mounting sunglasses/eyeglasses to the visor assembly. The plurality of both through-hole slots and partial cut-out slots, can
10 include different shapes, such as different geometrical shapes, letters, character outlines.

Further objects and advantages of this invention will be apparent from the following detailed description of the presently preferred embodiments which are illustrated schematically in the accompanying drawings.

15 BRIEF DESCRIPTION OF THE FIGURES

Fig. 1 is a top perspective view of the novel visor assembly.

Fig., 2 is a bottom perspective of the visor assembly of Fig. 1.

Fig. 3 is a top exploded perspective view of the visor assembly of Fig. 1.

Fig. 4 is a bottom exploded perspective view of the visor assembly of Fig. 3

20 Fig. 5 is a top view of the visor assembly of Fig. 1.

Fig. 5A is a cross-sectional view of the band rivet connection of Fig. 5 along arrow 5A.

Fig. 5B is a cross-sectional view of the charm connection of Fig. 5 along arrow 5B.

Fig. 6 is a bottom view of visor assembly of Fig. 5.

Fig. 7 is a right side view of the visor assembly of Figures 5-6.

25 Fig. 8 is a left side view of the visor assembly of Figures 5-6.

Fig. 9 is a front side view of the visor assembly of Figures 5-8.

- Fig. 10 is a rear side view of the visor assembly of Figures 5-8.
- Fig. 11 is a top front perspective view of the visor assembly of the preceding figures showing logo plate and charm ready to be installed.
- Fig. 12 is another top front perspective view of the visor assembly of Fig. 11 showing
- 5 logo plate and charms installed.
- Fig. 13 is a bottom front inside perspective view of the visor assembly of Fig. 11 showing logo plate and charm ready to be installed.
- Fig. 14 is a bottom front inside perspective view of the visor assembly of Fig. 13 showing logo plate and charm installed.
- 10 Fig. 15 is a top view of a logo plate for the visor assembly of the preceding figures.
- Fig. 16 is a front view of the logo plate of Fig. 15.
- Fig. 17 is a front right perspective view of the logo plate of Fig. 15.
- Fig. 18 is a rear right perspective view of the logo plate of Fig. 15.
- Fig. 19 is top view of a charm accessory for the visor assembly of the preceding figures.
- 15 Fig. 20 is a front view of the charm of Fig. 19.
- Fig. 21 is a front right perspective view of the charm of Fig. 19.
- Fig. 22 is a rear right perspective view of the charm of Fig. 19.
- Fig. 23 is a front view of a puncture tool for use with visor assembly.
- Fig. 24 is a side view of the puncture tool of Fig. 23.
- 20 Fig. 25 is a top view of another visor assembly.
- Fig. 26 is a top view of still another visor assembly.
- Fig. 27 is a perspective view of an adapter for mounting sunglasses/eyeglasses to the visor assembly.
- Fig. 28 is a side view of the adapter of Fig. 27.

Fig. 29 is a front view of the adapter of Fig. 27.

Fig. 30 is a front perspective view of a visor assembly with adapter of Fig. 27 and mounted sunglasses/eyeglasses.

Fig. 31 is a side view of the visor assembly, adapter and mounted sunglasses of Fig. 30.

5 Fig. 32 is a front view of the visor assembly, adapter and mounted sunglasses of Fig. 30.

DESCRIPTION OF THE PREFERRED EMBODIMENTS

Before explaining the disclosed embodiments of the present invention in detail it is to be understood that the invention is not limited in its applications to the details of the particular arrangements shown since the invention is capable of other embodiments.

10 Also, the terminology used herein is for the purpose of description and not of limitation.

A listing of components will now be described.

10 visor assembly.

20 Visor/brim.

30 Headband.

15 40 Back band.

50 Snap-in charm.

60 Snap-in logo plate.

70 Sweat band.

80 Through-hole cutouts and/or partial cut-outs for charms and logo plate.

20 90 Back band rivet.

100 Back band adjustment holes in headband.

110 Rivet hole in back band.

120 Back band alignment stud.

130 Studs to secure logo plate and charms into cutouts.

- 140. Puncture tool
- 142. front of tool
- 144. raised gripping surface
- 145. puncture tip
- 5 147. stem
- 148. stud/rear wall
- 150. visor assembly with different shaped cutouts
- 152. letter shaped cutout
- 154. star shaped cutout
- 10 158. half moon shaped cutout
- 160. visor assembly with more different shaped cutouts
- 162. triangle shaped cutout
- 164. rectangular/square shaped cutout
- 166. cartoon character shaped cutout
- 15 170. adapter for eyeglasses/sunglasses
- 172. front wall of adapter
- 174. curved hook
- 175. stem
- 178. stud/rear wall
- 20 180. eyeglasses/sunglasses
- 182. arm(s)
- 190. visor assembly for eyeglasses/sunglasses

The inventor of the subject invention is also the inventor on U.S. Design Patent D601,329 to Johns, which is incorporated by reference.

Fig. 1 is a top perspective view of the novel visor assembly 10. Fig., 2 is a bottom perspective of the visor assembly 10 of Fig. 1. Fig. 3 is a top exploded perspective view of the visor assembly 10 of Fig. 1. Fig. 4 is a bottom exploded perspective view of the visor assembly 10 of Fig. 3 Fig. 5 is a top view of the visor assembly 10 of Fig. 1.

Fig. 5A is a cross-sectional view of the band rivet connection of Fig. 5 along arrow 5A.

Fig. 5B is a cross-sectional view of the charm connection of Fig. 5 along arrow 5B.

Fig. 6 is a bottom view of visor assembly 10 of Fig. 5. Fig. 7 is a right side view of the visor assembly 10 of Figures 5-6. Fig. 8 is a left side view of the visor assembly 10 of Figures 5-6. Fig. 9 is a front side view of the visor assembly 10 of Figures 5-8. Fig. 10 is a rear side view of the visor assembly 10 of Figures 5-8.

Fig. 11 is a top front perspective view of the visor assembly 10 of the preceding figures showing logo plate and charm ready to be installed.

Fig. 12 is another top front perspective view of the visor assembly 10 of Fig. 11 showing logo plate and charms installed.

Fig. 13 is a bottom front inside perspective view of the visor assembly 10 of Fig. 11 showing logo plate and charm ready to be installed.

Fig. 14 is a bottom front inside perspective view of the visor assembly 10 of Fig. 13 showing logo plate and charm installed.

Fig. 15 is a top view of a logo plate for the visor assembly 10 of the preceding figures. Fig. 16 is a front view of the logo plate of Fig. 15. Fig. 17 is a front right

perspective view of the logo plate of Fig. 15. Fig. 18 is a rear right perspective view of the logo plate of Fig. 15. The logo plates can have indicia on a front surface portion, such as but not limited to advertisements, sports teams, names, pictures, and the like.

Fig. 19 is top view of a charm accessory for the visor assembly 10 of the preceding figures. Fig. 20 is a front view of the charm of Fig. 19. Fig. 21 is a front right perspective view of the charm of Fig. 19. Fig. 22 is a rear right perspective view of the charm of Fig. 19. The charm accessory can be a decorative part, such as but not limited to a Jibitz™. The decorative pieces, can include various types of shapes, such as but not limited to animals, fish, birds, cartoon characters, flowers, trees, and the like.

Referring to figures 1-22, the visor assembly can be comprised of two or three components. The main two components are the front part of the visor assembly which includes a visor portion 20 with front head band portion 30, that is separated from and attachable to a back band 40 type strap. A third component can be a sweatband 70 that can be attached into the inside wall of the head band portion 30.

The visor portion 20 with front band portion 30, and the back band(strap) 40 can be formed from or molded from a soft plastic, such as but not limited to EVA(ethylene vinyl acetate). The novel visor 10 can also be water proof, float in water, be anti-bacterial, have good clarity and gloss, barrier properties, low-temperature toughness, stress-crack resistance, hot-melt adhesive, and resistance to UV(ultra violet) radiation. EVA has little or no odor and is competitive with rubber and vinyl products in cost. The invention can be formed from other materials, similar to EVA, that also have similar properties.

The visor assembly 10 of the previous figures can have partial cutouts instead of completely through-hole cutouts 80. The partial cut-outs can have indentations through

the visor/brim 20 and/or through the headband 30 that are not complete through-holes. These partial cut-outs can be molded to have narrow thicknesses than the rest of the visor/brim 20 and headband 30 material. As such, the user can use a puncture tool 140 as described in Figures 23-24 to complete the cut-out through the visor/brim 20 and/or
5 headband 30 as desired. For example, a visor assembly 10 can have a mix of through-hole cutouts and partial cut-outs. Alternatively, the visor assembly can have all through-hole cutouts or all partial cut-outs.

Fig. 23 is a front view of a puncture tool 140 for use with visor assembly. Fig. 24 is a side view of the puncture tool 140 of Fig. 23. On the front 142 of the tool 140 can be
10 a gripping surface that can have raised ribs or grooves thereon, and extending downward can be a narrow tip 145. The stud/rear wall 148 can be joined to the front wall by a stem portion 147. In operation, the user can grip the tool 140 by pinching the front wall 142 and rear wall 148 between two fingers, and push the narrow tip 145 into a partial cut-out opening 80 as desired to mount charm(s) 50, logo plate(s) 60 thereon. The tool 140 can
15 also be stored on the visor assembly 1 by pushing the stud/rear wall 148 into a throughhole cut-out 80 on the visor assembly.

The invention can be distributed and/or sold in a package or kit form, having visor assembly 1, along with a plurality of logo plates 60 and decorative(charm) parts 50 and puncture tool 140, and sunglass/eyeglass adapter 170.

20 Although, the cut-out slots(sockets) 80, 100 for the labels 60 and charms 50 are shown to be circular, the sockets can have other geometrical shapes, such as but not limited to triangular, rectangular, hexagon, and the like. Still furthermore, the sockets can be customized into other desirable shapes such as but not limited to character outline

shapes, such as Mickey Mouse, animals, mammals, birds, fish, and any other desirable outline shape, and the like.

Fig. 25 is a top view of another visor assembly 150. Fig. 26 is a top view of still another visor assembly 160. Here, different shapes, such as letter shaped cutout 152, star shaped cutout 154, half moon shaped cutout 158, triangle shaped cutout 162, rectangular/square shaped cutout 164, and other shapes 166, such as cartoon character shaped cutout 166 can be formed into the visor assembly 150, 160.

Fig. 27 is a perspective view of an adapter 170 for mounting sunglasses/eyeglasses to the visor assembly 190 (shown in Figures 30-32). Fig. 28 is a side view of the adapter 170 of Fig. 27. Fig. 29 is a front view of the adapter 170 of Fig. 27. The adapter 170 can include a front wall 172 having a curved hook 174 fixed thereon, with a stem 175 to attach to a stud/rear wall 178.

Fig. 30 is a front perspective view of a visor assembly 190 with adapter of Fig. 27 and mounted sunglasses/eyeglasses 180. Fig. 31 is a side view of the visor assembly 190, adapter 170 and mounted sunglasses 180 of Fig. 30. Fig. 32 is a front view of the visor assembly 190, adapter 170 and mounted sunglasses 180 of Fig. 30. The user can push the stud/rear wall 178 of the adapter 170 through headband adjustment holes 100 on both sides of the visor assembly 190 with the free end of the hook 174 angled upward. Next, the arms 182 of the eyeglasses/sunglasses 180 can be positioned into the hook portions 174, with the glass portions of the eyeglasses/sunglasses 180 positioned on the visor/brim 20. The curved hooks 174 can be angled so that the arms 182 of the eyeglasses/sunglasses 180 are tightly held in place. The user can safely store their eyeglasses/sunglasses 180 on the visor assembly 190. And when the

eyeglasses/sunglasses 180 are needed, the user, can easily remove the eyeglasses/sunglasses 180 from the adapter 170 to wear them when needed.

While the invention shows plug on labels and charms, the invention can be used with other accessories. For example, a scalp cover can attach to the top of the visor assembly and have plug in base members that allow for the cover to protect the scalp of the wearer. Furthermore, a neck shade attachment formed from similar material or formed from cloth or fabric, can attach by plugable members to the rear of the band strap. Still furthermore, other accessories, such as but not limited to sunglass shades, and the like, can also be plugable onto the visor assembly.

While the invention has been described, disclosed, illustrated and shown in various terms of certain embodiments or modifications which it has presumed in practice, the scope of the invention is not intended to be, nor should it be deemed to be, limited thereby and such other modifications or embodiments as may be suggested by the teachings herein are particularly reserved especially as they fall within the breadth and scope of the claims here appended.

I claim:

1. A visor assembly, comprising:
a visor with headband formed from a flexible and pliable material;
5 a plurality of slot shapes on a front surface portion of the visor with headband; and
at least one accessory having a male member that mateably attaches into at least
one of the slots, wherein the accessory is both attachable and detachable from the visor
with headband.
- 10 2. The visor assembly of claim 1, further comprising:
a removable strap having ends that are attachable to left and right portions of the
headband, the removable strap being formed from the flexible and pliable material.
3. The visor assembly of claim 2, wherein the removable strap includes:
15 rivet members having inwardly protruding portions for being insertable into a
plurality of adjustment holes in the removable strap.
4. The visor assembly of claim 1, wherein the material includes EVA(ethylene vinyl
acetate).
20
5. The visor assembly of claim 1, wherein the accessory includes:
a logo plate, having indicia across a front surface of the logo plate.
6. The visor assembly of claim 1, wherein the accessory includes:
25 a decorative charm.
7. The visor assembly of claim 1, wherein the accessory includes:

both a logo plate and a decorative charm.

8. The visor assembly of claim 1, wherein the slot shapes include circular shapes.
- 5 9. The visor assembly of claim 1, wherein the slot shapes include noncircular geometrical shapes.
10. The visor assembly of claim 1, wherein the slot shapes include outline shapes of different characters and objects.
- 10
11. The visor assembly of claim 1, wherein the slot shapes include through-hole cutouts through the visor.
12. The visor assembly of claim 1, wherein the slot shapes include partial cutouts
- 15 through only a surface portion of the visor.
13. The visor assembly of claim 12, further comprising:
a puncture tool for puncturing a partial-cutouts into a through-hole cutout.
- 20 14. The visor assembly of claim 1, further comprising:
an adapter for attaching sunglasses/eyeglasses to the visor assembly.
15. A visor assembly, comprising:
a visor with headband formed from a flexible and pliable material;
25 a plurality of both through-hole slots and partial cut-out slots along a front surface portion of the visor with headband;

a removable strap having ends that are attachable to left and right portions of the headband, the removable strap being formed from the flexible and pliable material; and

a plurality of accessories, each accessory having a male member that mateably attaches into at least one of the through-hole slots and partial cut-out slots, wherein the accessories are both attachable and detachable from the visor with headband, and wherein the accessories are selected from logo plates and decorative charms.

16. The visor assembly of claim 15, wherein the removable strap includes:
rivet members having inwardly protruding portions for being insertable into a plurality of adjustment holes in the removable strap.

17. The visor assembly of claim 15, wherein the flexible and pliable material includes: EVA(ethylene vinyl acetate).

18. The visor assembly of claim 15, wherein the accessories further include:
a puncture tool for punching out the partial cutout slots, and an adapter for mounting sunglasses/eyeglasses to the visor assembly.

19. A visor assembly kit, comprising in combination:
a visor with headband formed from a flexible and pliable material;
a plurality of both through-hole slots and partial cut-out slots along a front surface portion of the visor with headband; and
a plurality of accessories, each accessory having a male member that mateably attaches into at least one of the through-hole slots and partial cut-out slots, wherein the accessories are both attachable and detachable from the visor with headband, and wherein the accessories are selected from the group consisting of logo plates and decorative

charms and a puncture tool to punch out a partial cutout, and an adapter for mounting sunglasses/eyeglasses to the visor assembly.

20. The visor assembly kit of claim 19, wherein the plurality of both through-hole
5 slots and partial cut-out slots, include different shapes.

21. The visor assembly kit of claim 19, wherein the accessories include both decorative charms and a puncture tool.

10 22. The visor assembly kit of claim 21, wherein the puncture tool includes:
a front wall spaced apart from a rear wall by a stem; and
a narrow tip on the front wall, wherein the puncture tool is storable on at least one
of the through-hole slots and the partial cut-out slots of the visor with the headband.

15 23. The visor assembly of claim 13, wherein the puncture tool includes:
a front wall spaced apart from a rear wall by a stem; and
a narrow tip on the front wall, wherein the puncture tool is storable on at least one
of the through-hole slots and the partial cut-out slots of the visor with the headband.

20 24. The visor assembly of claim 18, wherein the puncture tool includes:
a front wall spaced apart from a rear wall by a stem; and
a narrow tip on the front wall, wherein the puncture tool is storable on at least one
of the through-hole slots and the partial cut-out slots of the visor with the headband.

25

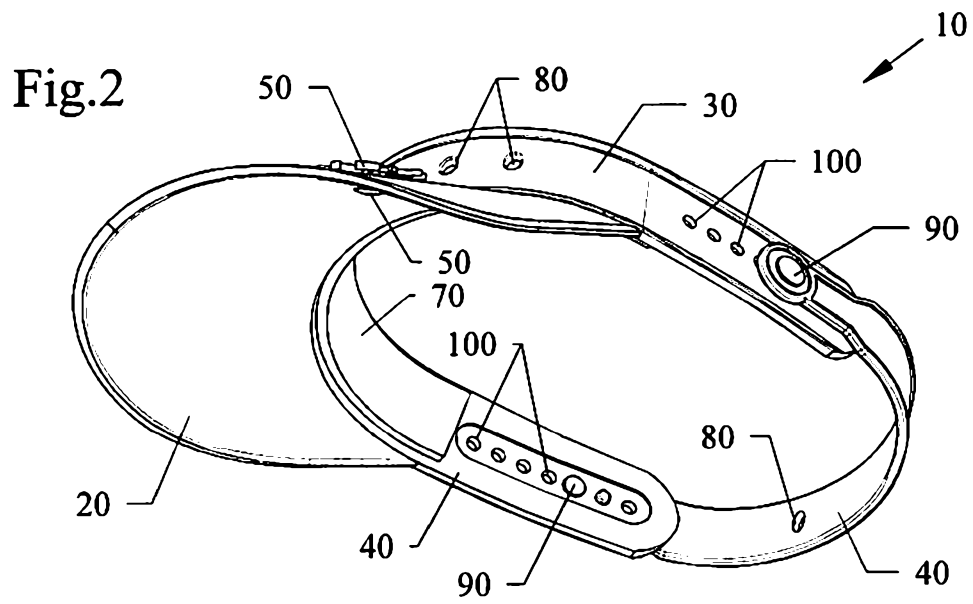
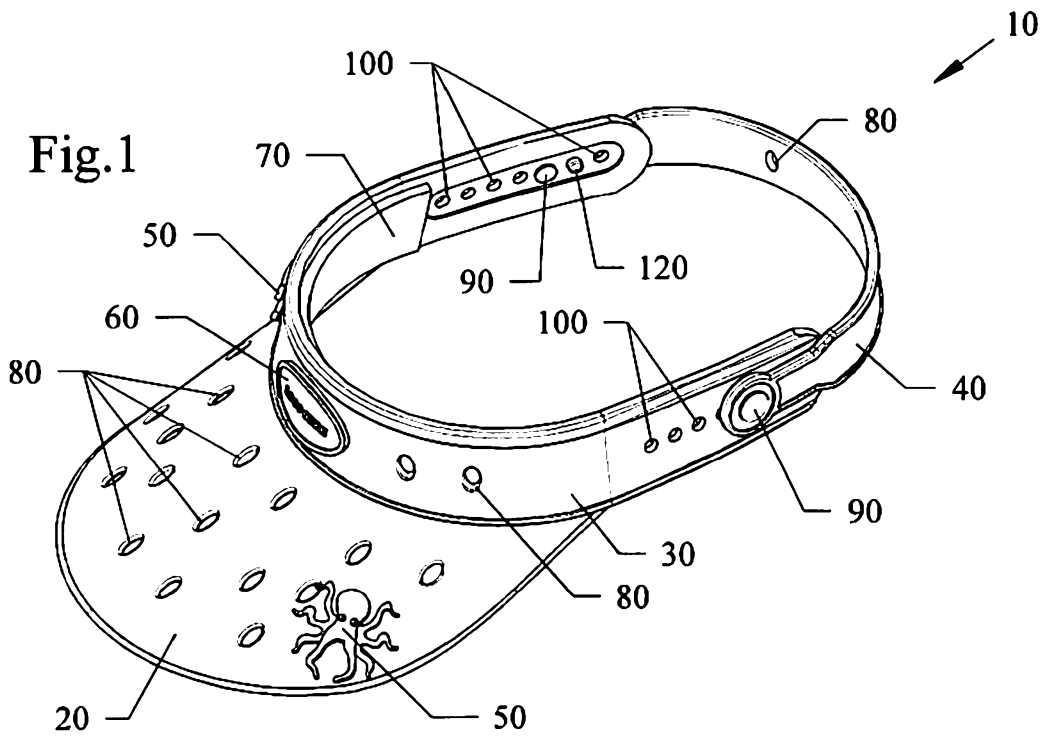

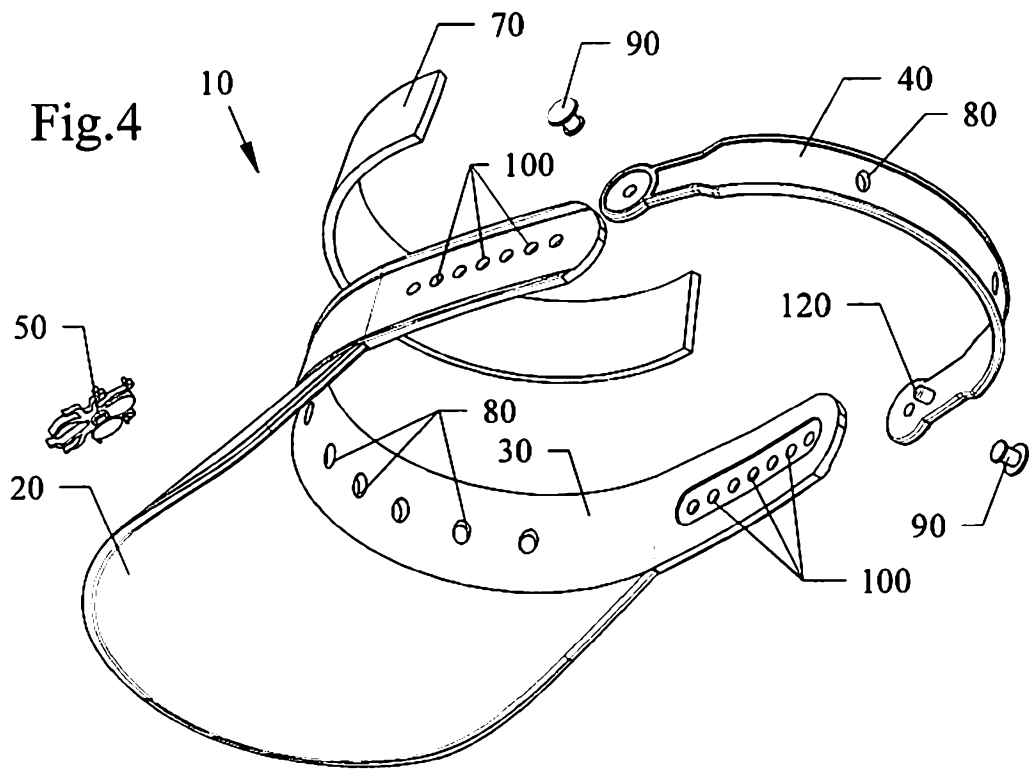
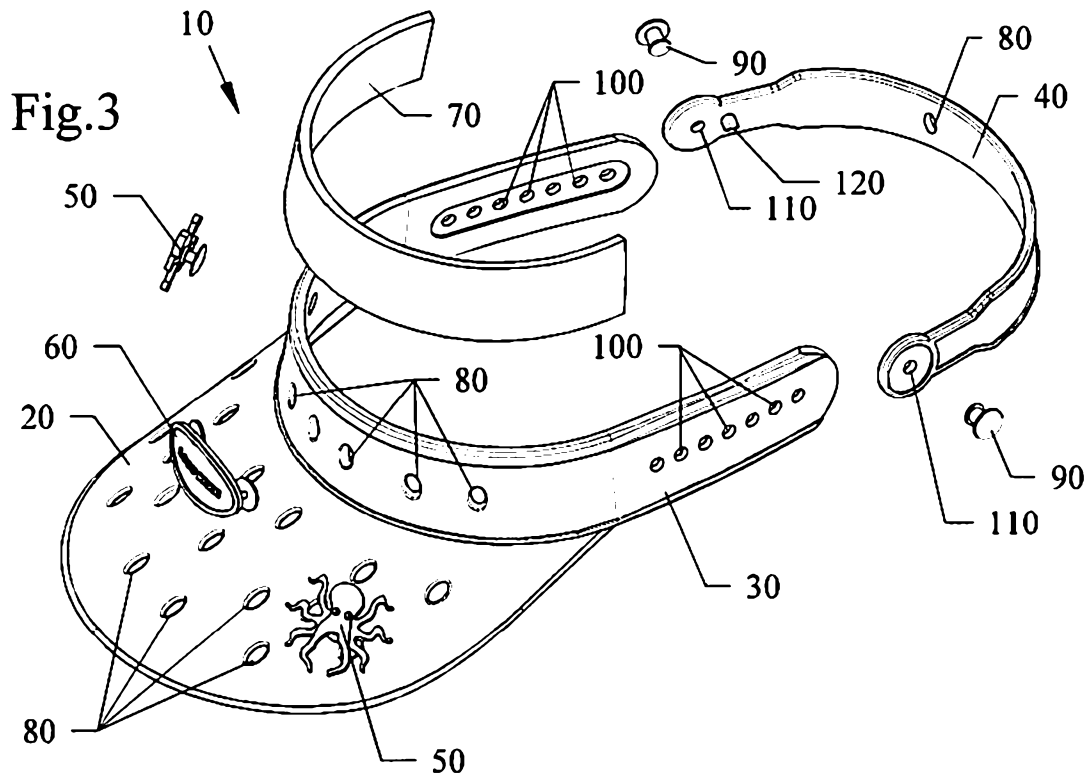

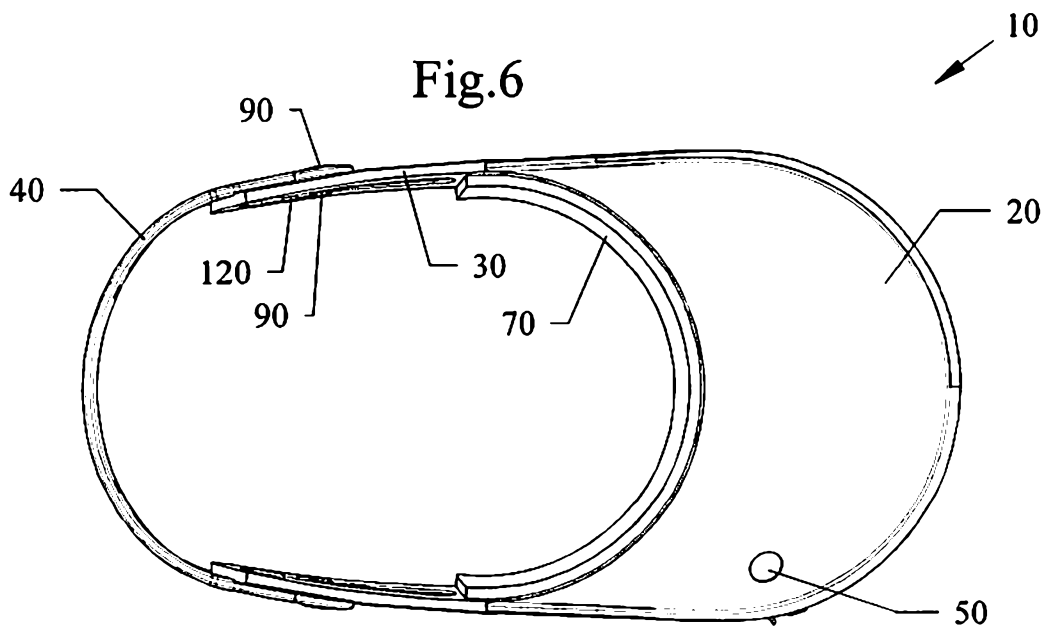
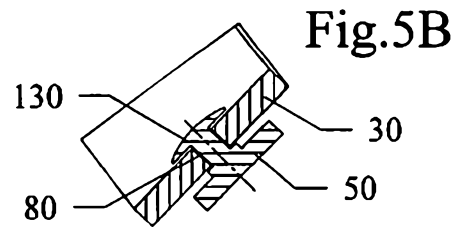
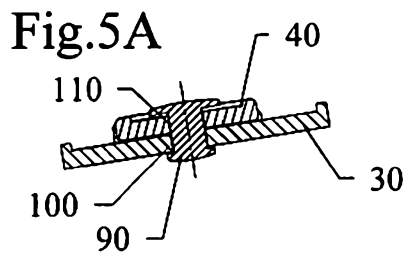
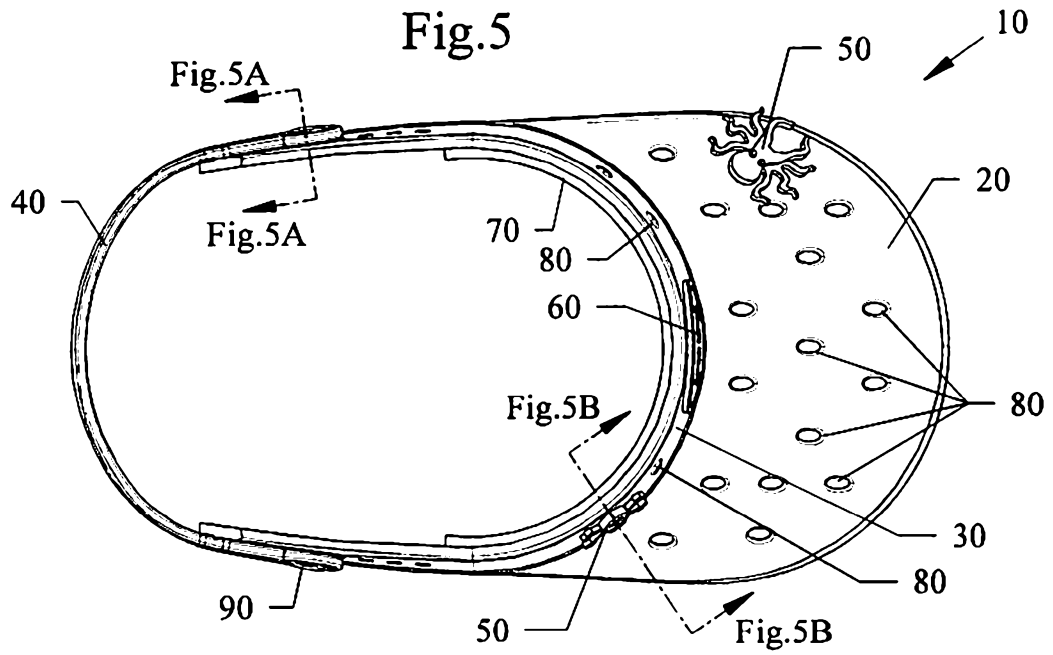

Fig.7

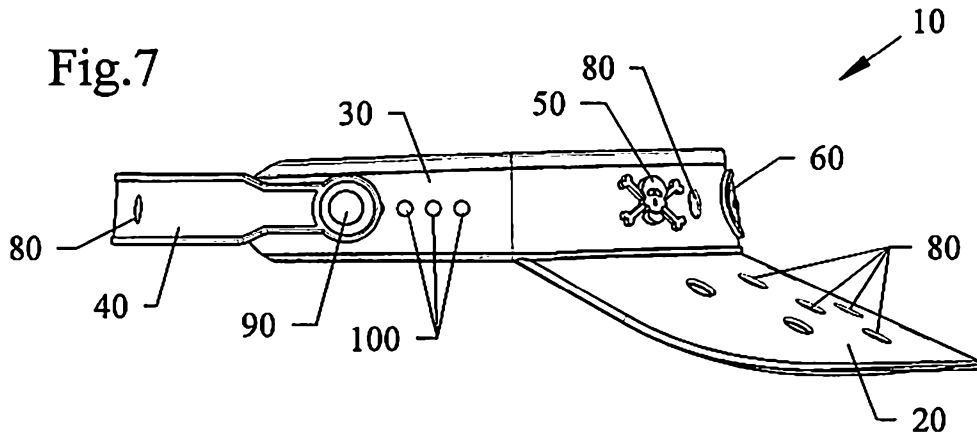

Fig.8

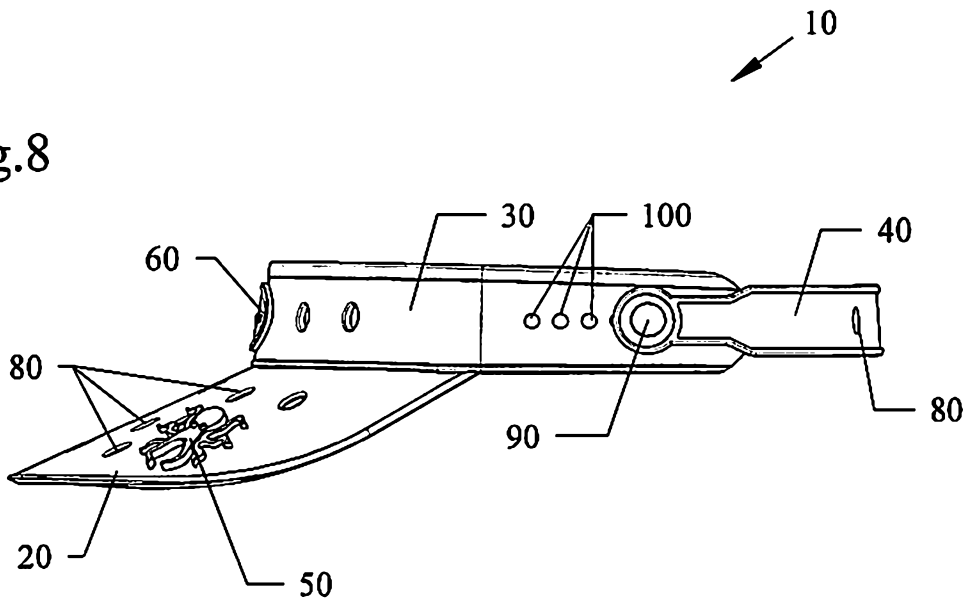

Fig.9

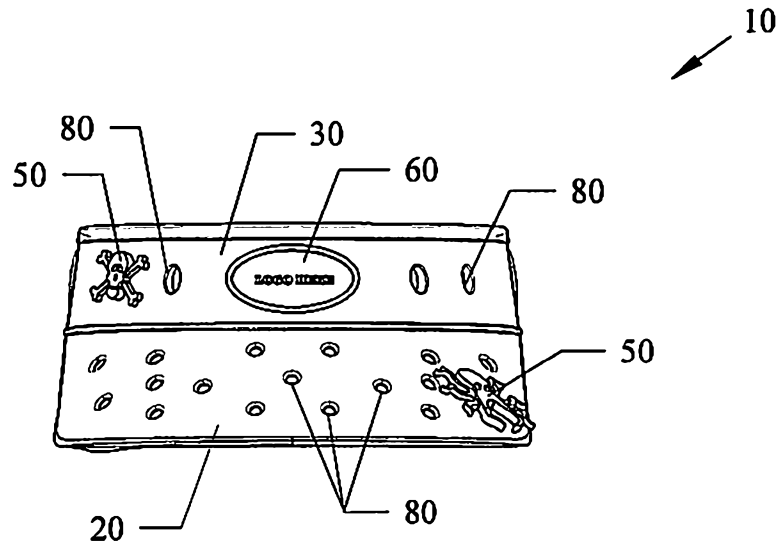

Fig.10

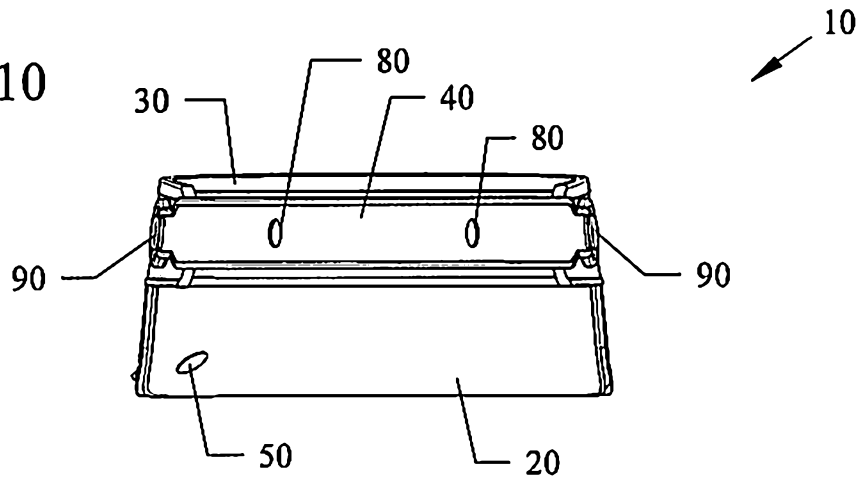

Fig.11

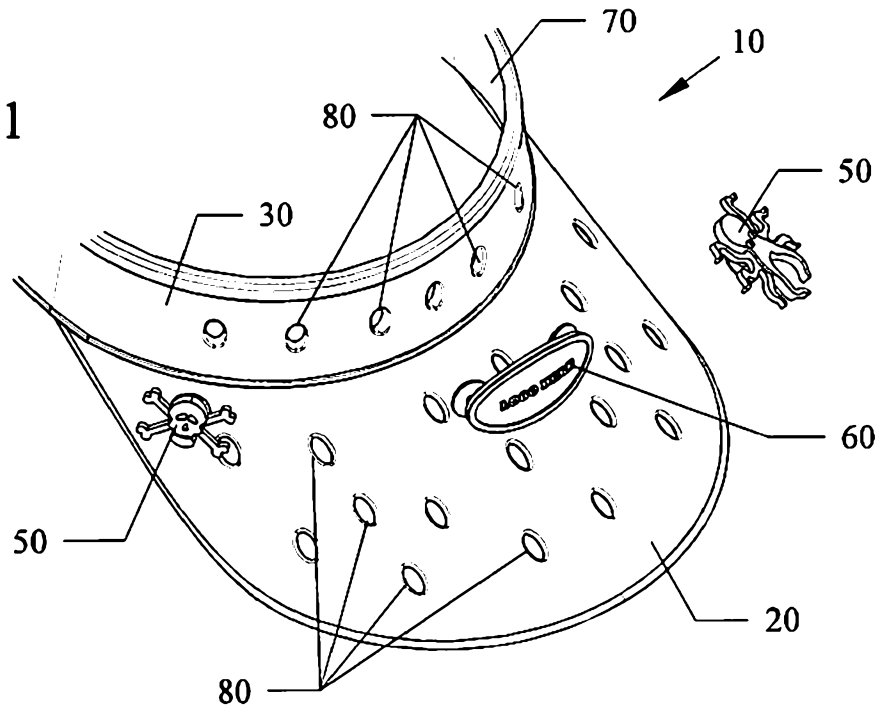

Fig.12

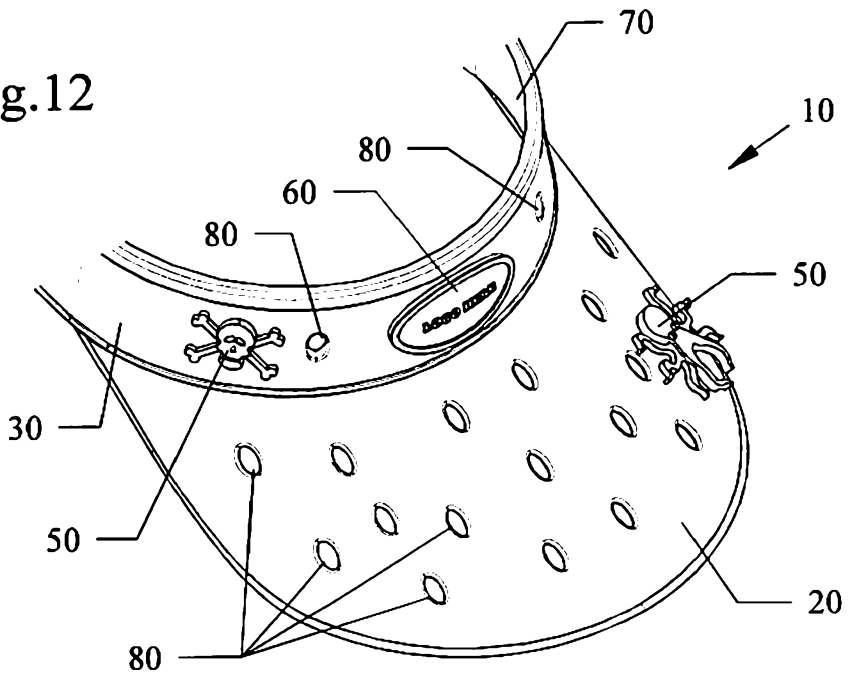

Fig.13

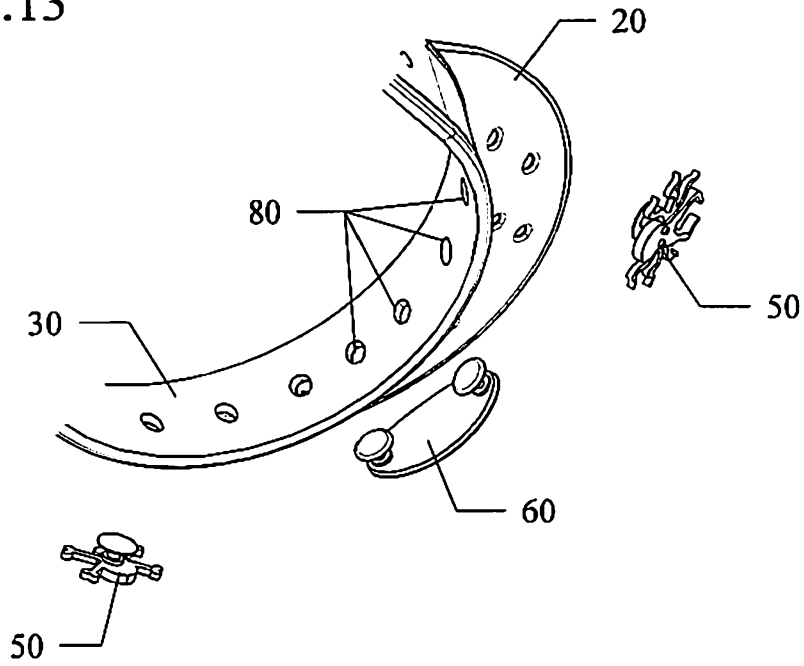
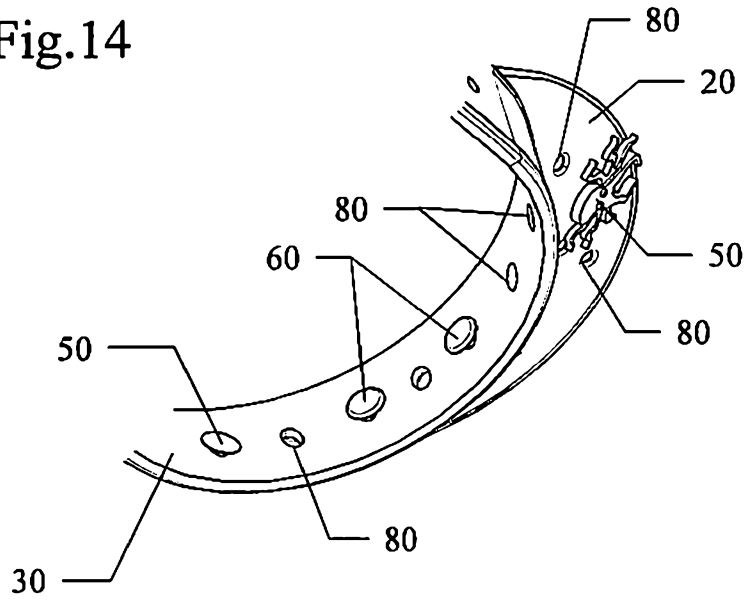
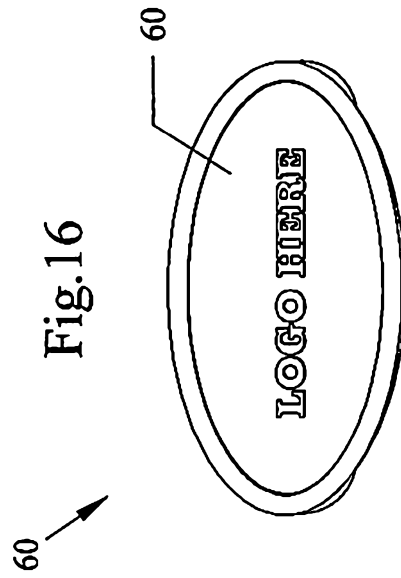
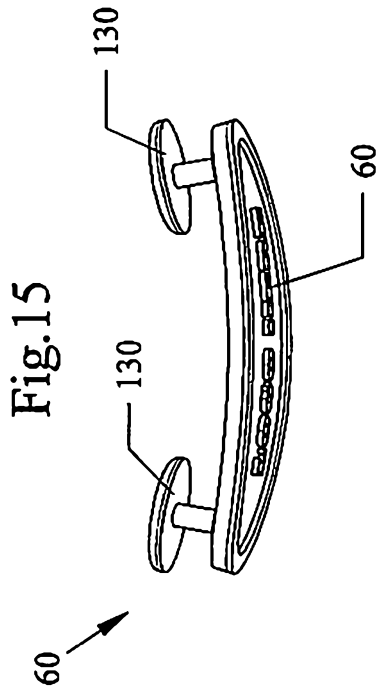
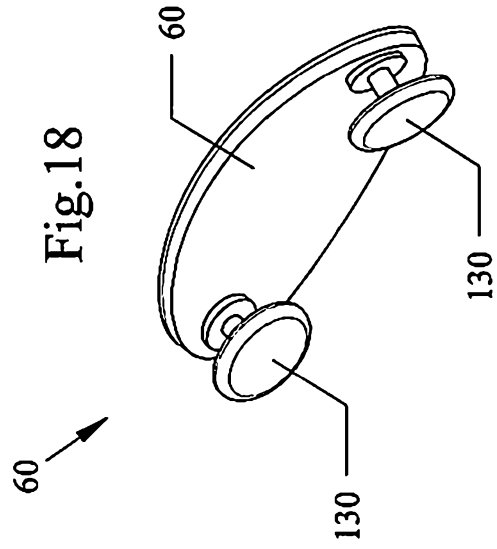
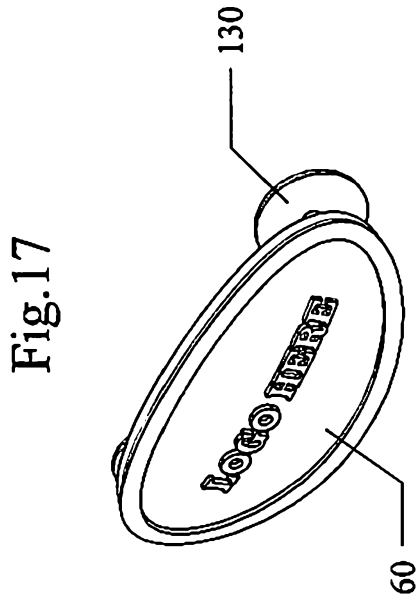
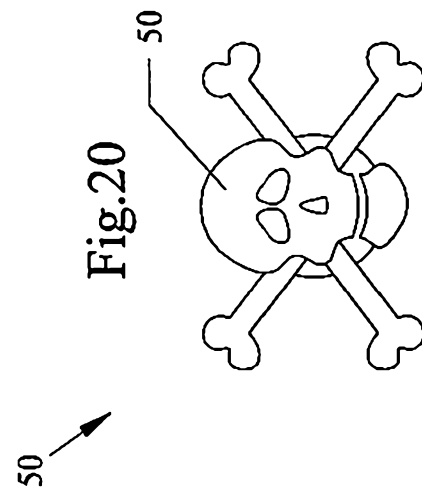
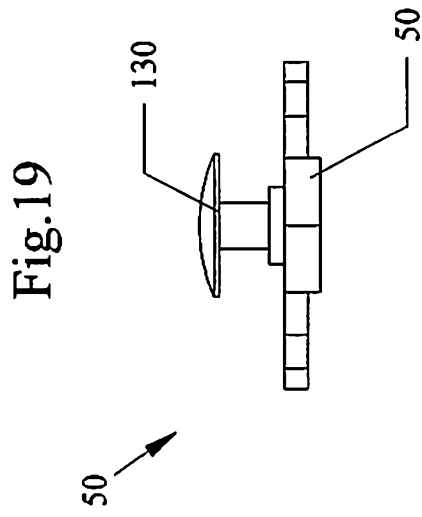
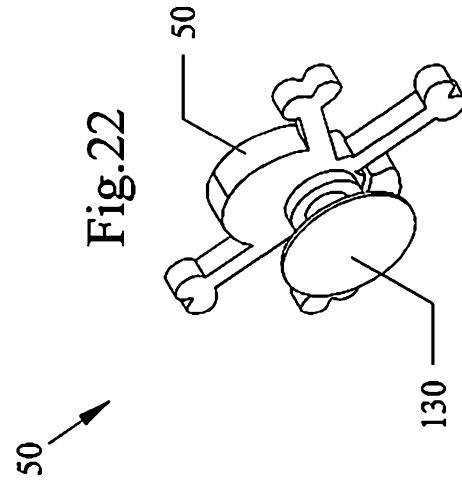
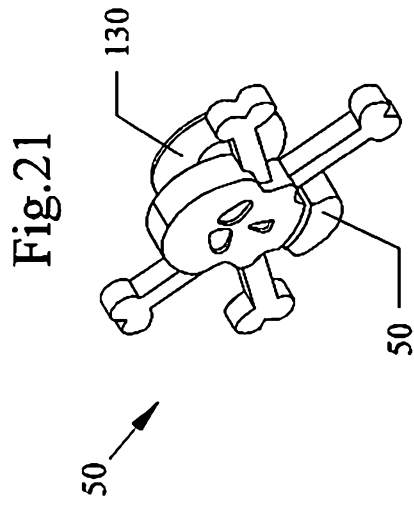

Fig.14







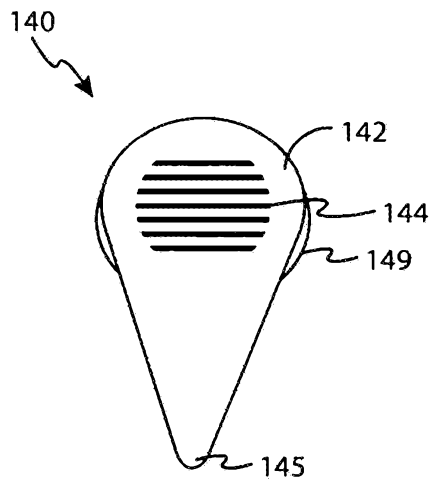

FIG. 23

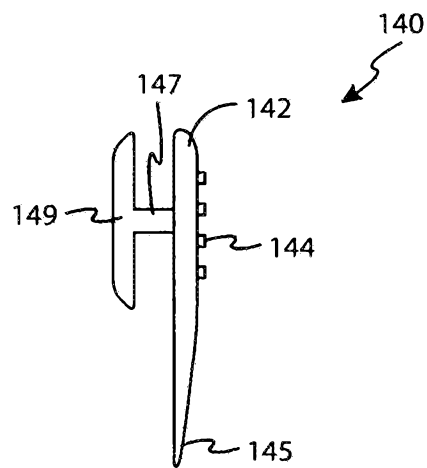
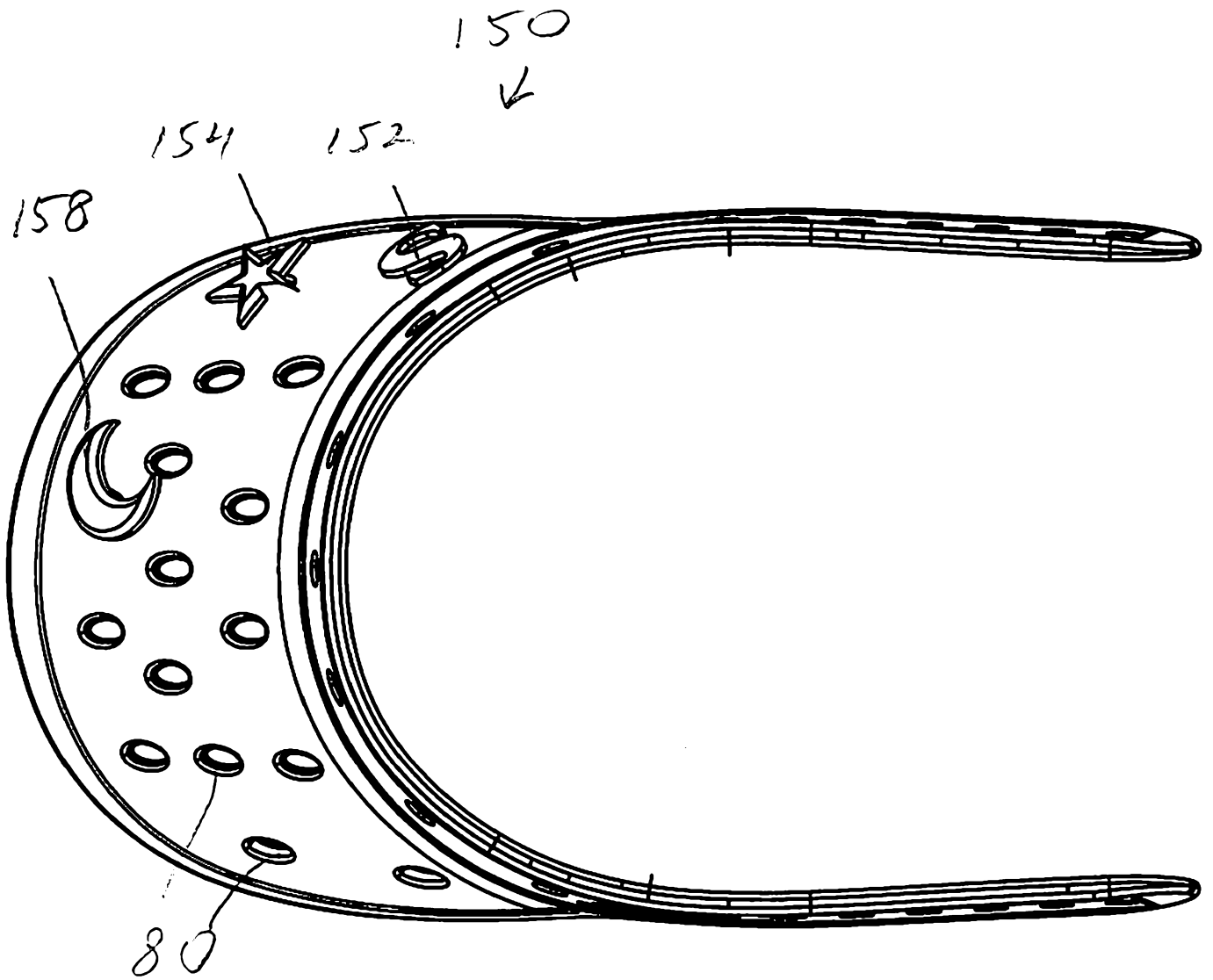

FIG. 24

Fig. 25



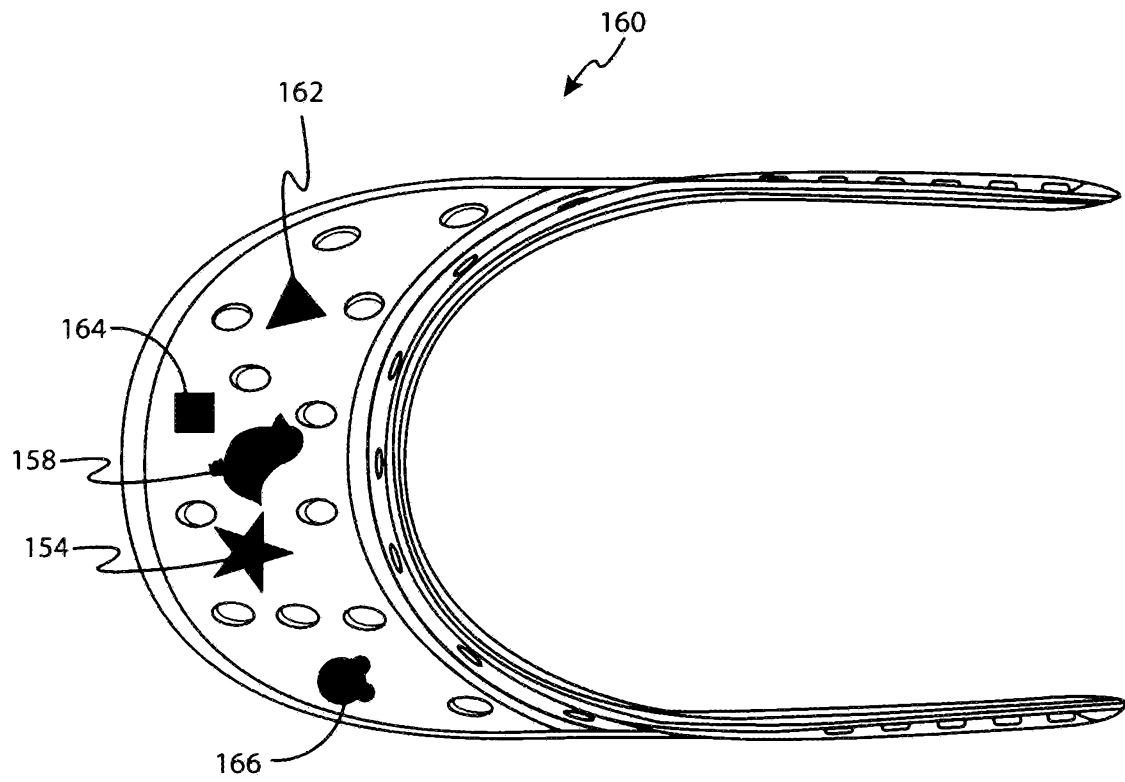

FIG. 26

Fig. 27

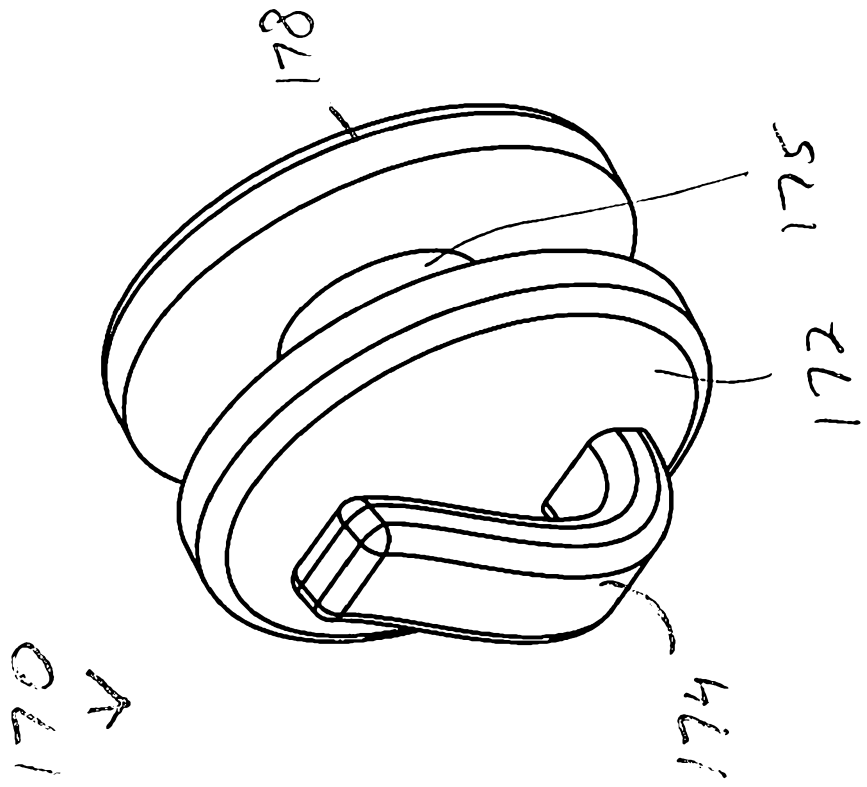

Fig. 29

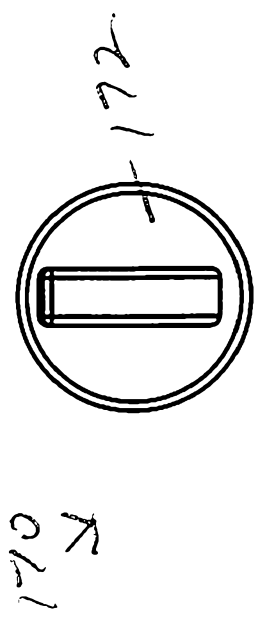
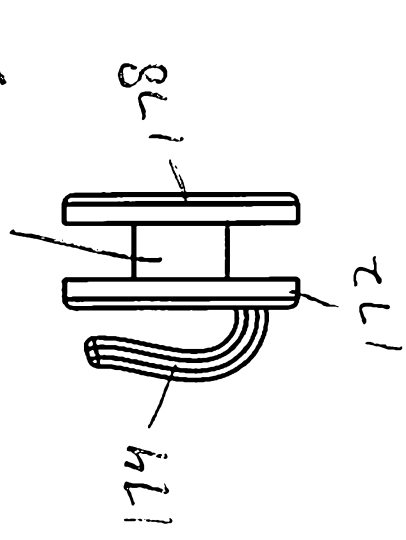
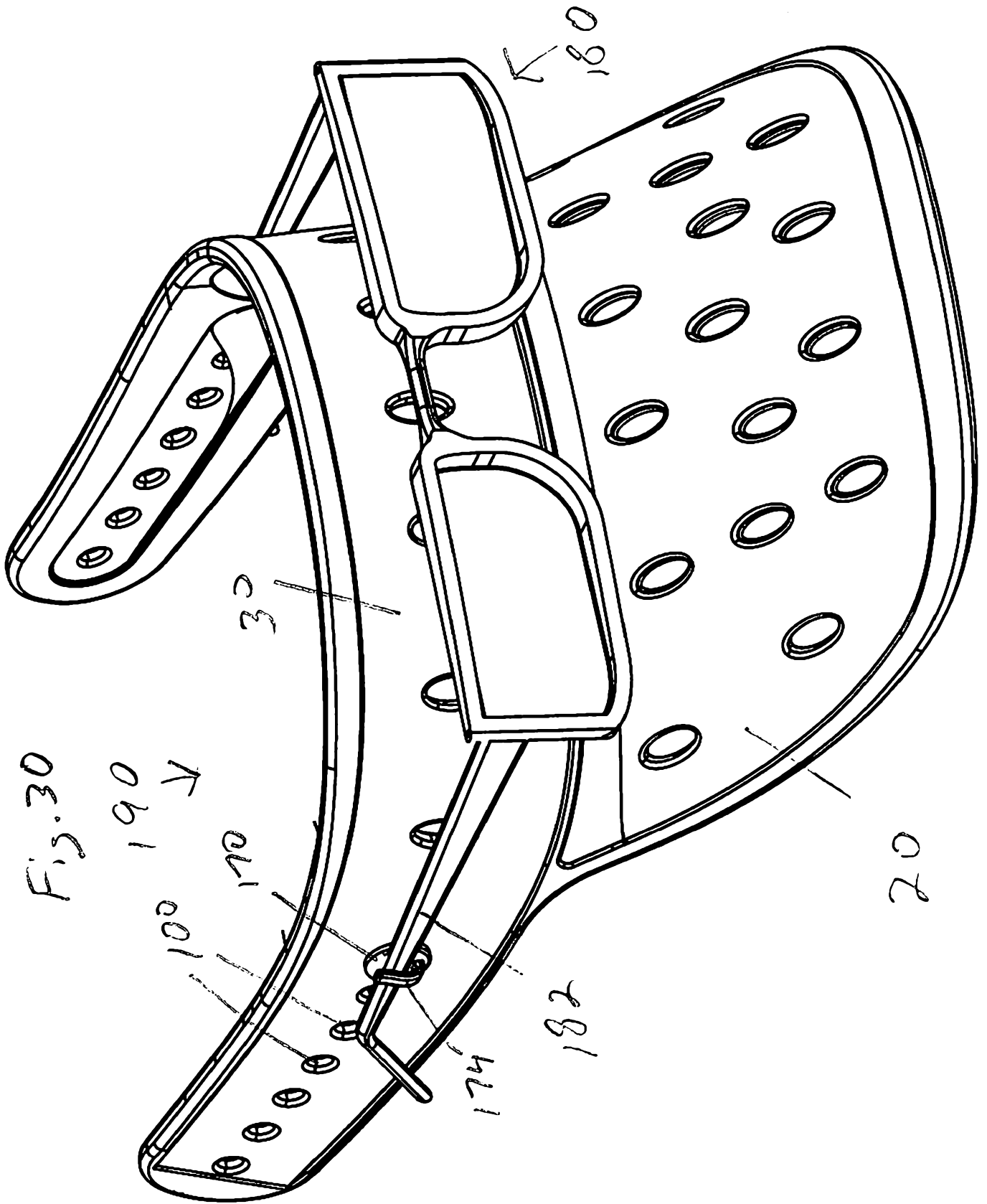

Fig. 28





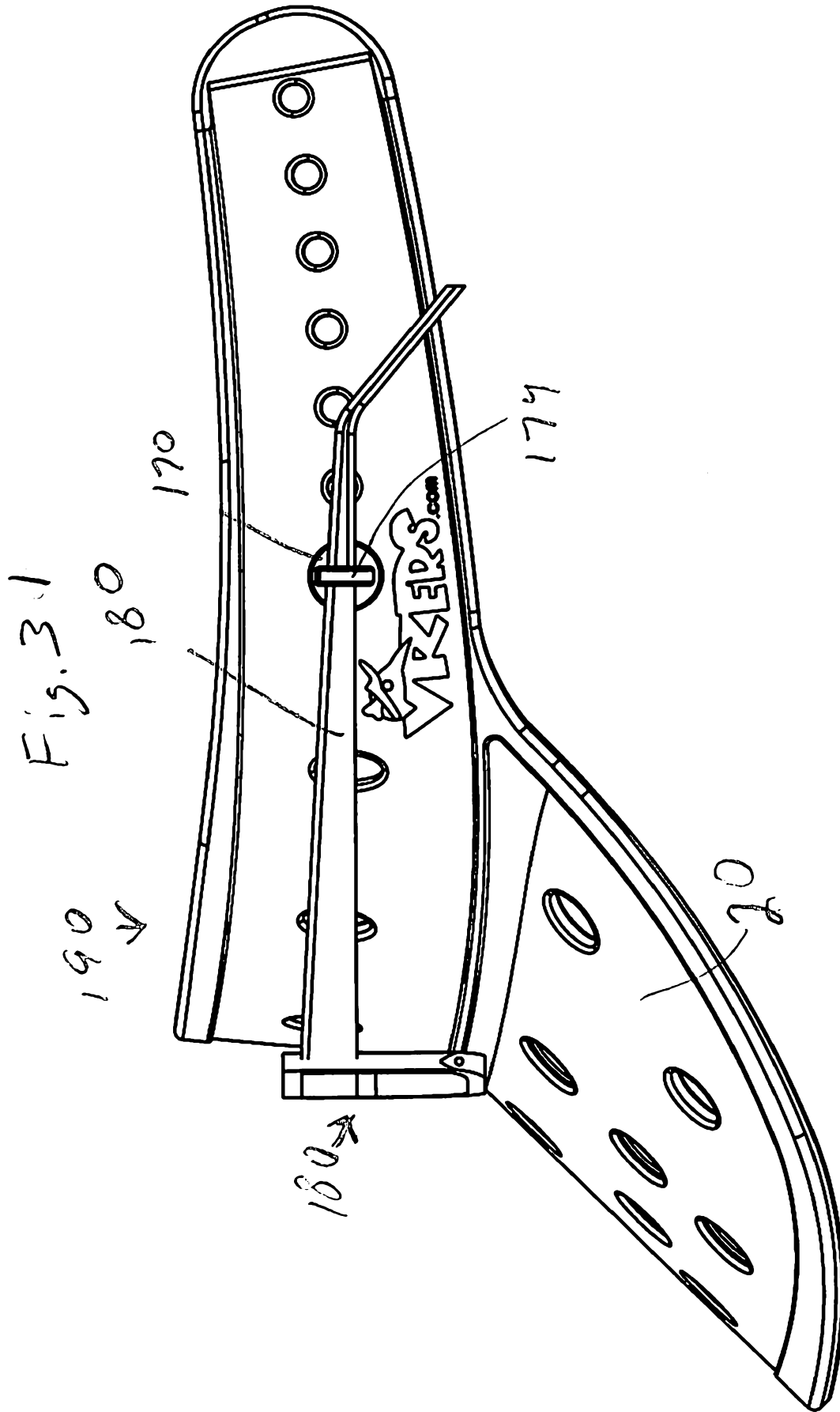

Fig. 32

