

(No Model.)

J. W. KAISER.  
DRAFTING COMPASSES.

No. 559,177.

Patented Apr. 28, 1896.

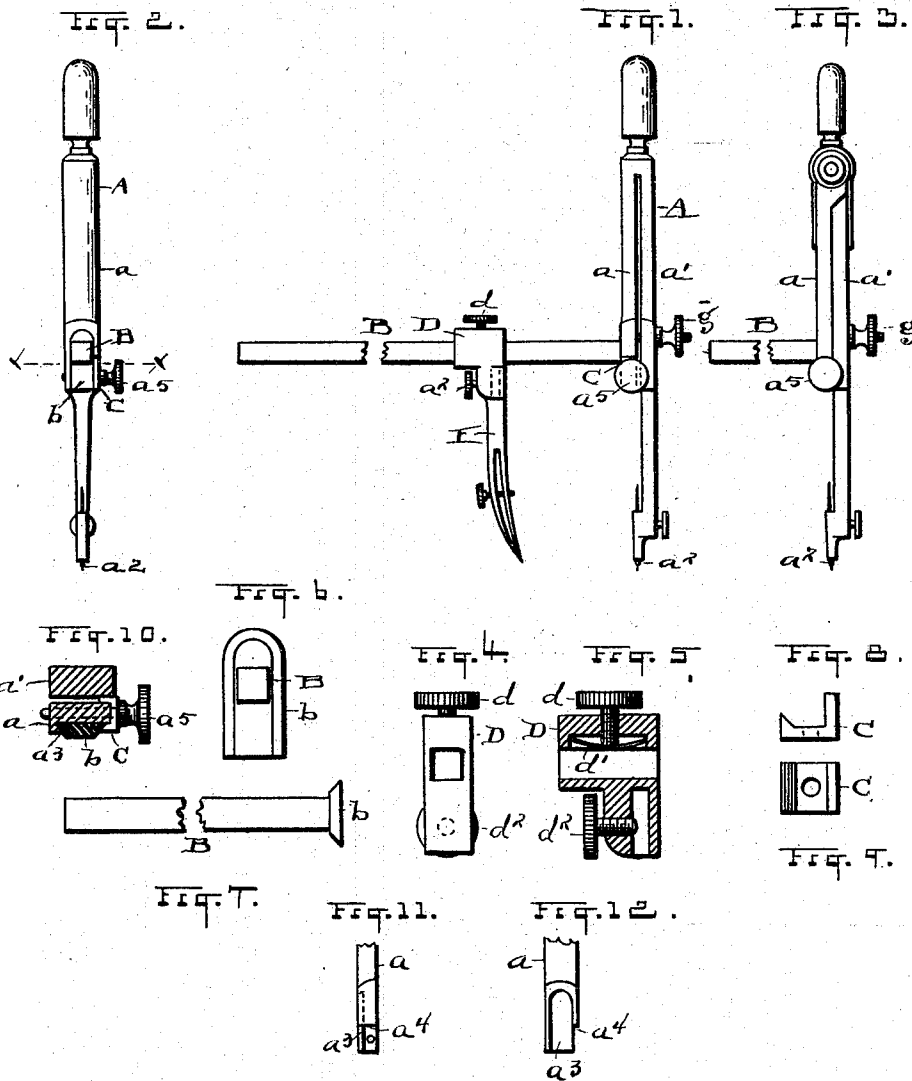

ATTEST

*R. B. Moore*  
*H. E. Mendenhall*

INVENTOR.

*Jacob W. Kaiser*

By *H. J. Fisher* ATTY

# UNITED STATES PATENT OFFICE.

JACOB W. KAISER, OF CLEVELAND, OHIO.

## DRAFTING-COMPASS.

SPECIFICATION forming part of Letters Patent No. 559,177, dated April 28, 1896.

Application filed June 5, 1893. Serial No. 476,673. (No model.)

*To all whom it may concern:*

Be it known that I, JACOB W. KAISER, a citizen of the United States, residing at Cleveland, in the county of Cuyahoga and State of Ohio, have invented certain new and useful Improvements in Drafting-Compasses; and I do hereby declare that the following is a full, clear, and exact description of the invention, which will enable others skilled in the art to which it appertains to make and use the same.

My invention relates to drafting-compasses; and the object of the invention is to provide attachments for compasses whereby a compass of otherwise comparatively small size may be utilized to describe a circle considerably larger than ordinarily is possible, the attachment being constructed to give the instrument the larger reach with equally good results, all substantially as shown and described, and particularly pointed out in the claims.

In the accompanying drawings, Figure 1 is a side elevation of a compass having my improved attachment; and Fig. 2 is an elevation at right angles to Fig. 1, looking in from the left thereof. Fig. 3 is a side elevation of a common form of compass constructed to receive my improved attachment. Fig. 4 is a plain elevation of the attachment-socket for receiving the pen or pencil holder or stem; and Fig. 5 is a central sectional elevation of said socket, both said views being enlarged to more clearly develop their construction. Fig. 6 is an end elevation of the detachable horizontal bar adapted to receive the socket for the pen or pencil holder and looking from the outer extremity of said bar; and Fig. 7 is a longitudinal elevation of said bar, the beveled head of the bar being shown in both views. Fig. 8 is an edge view, and Fig. 9 is a plan view, both greatly enlarged, of the little clamp adapted to fit the notch in the extremity of the short leg of the instrument and to overlap part of the beveled edge of the head of the horizontal bar and to fasten it in position. Fig. 10 is a cross-section of the implement on a line corresponding substantially to 10 10, Fig. 2, and showing the relation of the clamp shown in Figs. 8 and 9 to the said leg and beveled head. Figs. 11 and 12 are side elevations of the short leg of

the implement, showing the notch or recess which is adapted to receive the clamp shown in Figs. 8, 9, and 10.

All the detail and sectional views are enlarged, and some of them in the original drawings are considerably enlarged over and above the usual size of the parts, so as to more clearly disclose their construction.

In Figs. 1 and 2, A represents the body of the instrument, which is split centrally and formed with two parts or legs  $a$  and  $a'$ . The leg  $a'$  has the usual pivot or needle point  $a^2$  at its extremity, and the short leg or stem  $a$  has a flat seat  $a^3$ , Fig. 12, with an undercut or dovetailed edge adapted to receive the beveled head  $b$  of the horizontal bar B, which is arranged at right angles to the said leg. It is designed that the bar and the seat for the head thereof in the leg  $a$  shall be so constructed as not only to be firmly fixed in position when required, but also to be easily removable or detachable, and to this end the head of the bar B is beveled about its edge, as shown, to adapt it to the dovetailed or undercut seat  $a^3$ , and the said seat is open at its bottom, so that the head may easily be slipped into place. Then to fasten the head I further provide a clamp C, which occupies the notch  $a^4$  in the extremity of leg  $a$ , as seen in Fig. 11. If it were entirely practical to make the engagement of the said head in the seat  $a^3$  by frictional engagement, the special construction of clamp here shown would not be required; but this would necessitate the making of the parts to fit exceedingly closely to begin with, and then as they became somewhat worn by continual use they might no longer hold and would require something more to fasten them together. I have therefore found that a clamp of substantially the character here shown, in addition to the dovetailed and beveled edges, is desirable and advantageous. The said clamp is pressed or held with a screw  $a^5$  against the head  $b$ .

The horizontal bar B is made in different lengths, so that a larger or a smaller circle or radius may be described. This bar for an ordinary instrument may be one, two, three, four, or more inches long, and I have found it advantageous to keep on hand the several lengths, so that I can in a moment change from one to the other as the work may re-

quire. Upon this bar is a sliding socket or head D, constructed to fit somewhat snugly upon the said bar, yet adapted to slide back and forth, and is held by the set-screw  $d$  and the spring  $d'$  within the said socket or head, as clearly seen in Fig. 5. The pencil-holder or pen E has a shank, as usual, constructed to be attached to this socket, as seen in Fig. 1, and to be locked by the set-screw  $d^2$ . With this construction the said socket D may be moved as far out as the limits of the horizontal bar will allow, so as to describe a very large circle, or it may be moved anywhere along thereon to describe a smaller circle, though for smaller circles or narrower work a shorter bar ordinarily is used.

It will be noticed in Fig. 1 that the two legs  $a$  and  $a'$  are in one piece with the body or stem of the instrument, though split apart, as therein shown. This gives them more or less relative spring, which enables the finer adjustment to be made by screw  $g$  after the primary adjustment has been made by screw  $d^2$  or head D. In this way the legs  $a$  and  $a'$  may be spread somewhat or drawn together, and a like adjustment may be made in the modification shown in Fig. 3, in which the said legs have a pivoted connection.

If the body were made without being split or the pivoted sections shown in Fig. 3, the bar B and the support and adjustment of the parts would be made substantially as herein described, except the finer adjustment by means of the screw  $g$ .

The term "drafting instrument," as used herein, is intended to be considered as comprising all instruments in this line and used for laying out work or for marking or drafting or for kindred uses.

Having thus described my invention, what I claim as new, and desire to secure by Letters Patent, is—

1. A drafting instrument having two legs of unequal length, the longer leg provided with a point and a removable bar secured to the shorter leg and projecting therefrom on the side opposite the longer leg, substantially as set forth.

2. A drafting instrument having a long leg provided with a point and a short leg provided with a seat for a detachable bar, in combination with said detachable bar fixed temporarily to said short leg and separate from the long leg of the instrument, substantially as set forth.

3. The instrument described having two legs of unequal length, a bar secured to the shorter leg and a movable point-holder thereon, and a screw extending through the longer leg into the shorter to make relatively fine adjustments between the points of the instrument, substantially as set forth.

4. The instrument having long and short legs as described, the short leg provided with a seat for a detachable bar on its side opposite the long leg, in combination with said bar having a head fitted to the said seat and a clamp to engage and lock said head, substantially as set forth.

5. The instrument described having two legs of unequal length and a head in which said legs are permanently united, in combination with a detachable bar fixed to the shorter leg at its side opposite the longer leg and independently of said longer leg, and means at the lower end of the shorter leg to adjust the said legs relatively to each other, substantially as set forth.

Witness my hand to the foregoing specification.

JACOB W. KAISER.

Witnesses:

H. T. FISHER,  
GEORGIA SCHAEFFER.