

The Patents Act 1952

DECLARATION IN SUPPORT

of the (Convention) Application made by: Medical Research Council

(hereinafter termed "the applicant" ) for a patent (of addition) for an invention entitled

Altered Antibodies

~~XXX~~ MARTIN WOOD

of Medical Research Council, 20 Park Crescent, London W1N 4AL England

do solemnly and sincerely declare as follows:

~~XXX I am the applicant~~ or

I am ~~XXX~~ authorised by the applicant to make this declaration on its/their behalf.

The basic applications as defined by sections 141 and 142 of the Act ~~was~~ were made

- Great Britain (8706425) on 18 March 1987
- Great Britain (8718897) on 10 August 1987
- in Great Britain (8728042) on 1 December 1987
- in PCT (PCT/GB88/00211) on 18 March 1988

by Medical Research Council

The basic applications referred to in this paragraph ~~is~~ are the first applications made in a Convention country in respect of the invention the subject of the application.

~~XXX~~

or Gregory Paul Winter, Alexander Robert Duncan and Dennis Raymond Burton  
OF: 64 Cavendish Avenue, Cambridge, England and 5 Harvey Road, Cambridge, England and 41 Carsick Hill Road, Sheffield S10, England.

~~is~~ are the actual inventors of the invention and the facts upon which the applicant ~~is~~ are entitled to make the application are as follows: We are entitled to rights in the invention by virtue of assignment from the inventors.

Declared at London, England this 15th day of November 1988

Signed: *M. R. Winter*

---

**(12) PATENT ABRIDGMENT (11) Document No. AU-B-14803/88**  
**(19) AUSTRALIAN PATENT OFFICE (10) Acceptance No. 600575**

---

(54) Title  
**ALTERED ANTIBODIES**

International Patent Classification(s)  
(51)<sup>4</sup> **C07K 015/12 A61K 043/00 A61K 049/02 C12N 015/00**  
**A61K 039/095**

(21) Application No. : **14803/88** (22) Application Date : **18.03.88**

(87) WIPO Number : **WO88/07089**

(30) Priority Data

(31) Number	(32) Date	(33) Country
<b>8706425</b>	<b>18.03.87</b>	<b>GB UNITED KINGDOM</b>
<b>8718897</b>	<b>10.08.87</b>	<b>GB UNITED KINGDOM</b>
<b>8728042</b>	<b>01.12.87</b>	<b>GB UNITED KINGDOM</b>

(43) Publication Date : **10.10.88**

(44) Publication Date of Accepted Application : **16.08.90**

(71) Applicant(s)  
**MEDICAL RESEARCH COUNCIL**

(72) Inventor(s)  
**GREGORY PAUL WINTER; DENNIS RAYMOND BURTON; ALEXANDER ROBERT DUNCAN**

(74) Attorney or Agent  
**GRIFFITH HACK & CO. SYDNEY**

(57) Claim

1. A modified antibody of the class IgG in which at least one amino acid residue in the constant portion (as herein defined) has been replaced by a different residue altering an effector function of the antibody as compared with unmodified antibody.

6. An antibody according to claim 5, wherein at least one of the amino acid residues 234, 235, 236 and 237 of the heavy chain has been replaced by a different residue(s).

11. An antibody according to claim 10, wherein at least one of the residues 318, 320 and 322 has been changed to Ala, reducing Clq binding affinity.

PCT

AU-AI-14803/88

WORLD INTELLECTUAL PROPERTY ORGANIZATION  
International Bureau

000575



INTERNATIONAL APPLICATION PUBLISHED UNDER THE PATENT COOPERATION TREATY (PCT)

<p>(51) International Patent Classification<sup>4</sup> : <b>C12N 15/20, A61K 39/395</b></p>	<p><b>A1</b></p>	<p>(11) International Publication Number: <b>WO 88/ 07089</b> (43) International Publication Date: 22 September 1988 (22.09.88)</p>	
<p>(21) International Application Number: PCT/GB88/00211 (22) International Filing Date: 18 March 1988 (18.03.88) (31) Priority Application Numbers: 8706425 8718897 8728042 (32) Priority Dates: 18 March 1987 (18.03.87) 10 August 1987 (10.08.87) 1 December 1987 (01.12.87) (33) Priority Country: GB (71) Applicant (for all designated States except US): MEDICAL RESEARCH COUNCIL [GB/GB]; 20 Park Crescent, London W1N 4AL (GB). (72) Inventors; and (75) Inventors/Applicants (for US only) : WINTER, Gregory, Paul [GB/GB]; 64 Cavendish Avenue, Cambridge (GB). DUNCAN, Alexander, Robert [GB/GB]; 5 Harvey Road, Cambridge (GB). BURTON, Dennis, Raymond [GB/GB]; 41 Carsick Hill Road, Sheffield S10 (GB).</p>		<p>(74) Agents: MATTHEWS, Heather, Clare et al.; Keith W. Nash &amp; Co., Pearl Assurance House, 90-92 Regent Street, Cambridge CB2 1DP (GB). (81) Designated States: AT (European patent), AU, BE (European patent), CH (European patent), DE (European patent), FR (European patent), GB, GB (European patent), IT (European patent), JP, LU (European patent), NL (European patent), SE (European patent), US. <b>Published</b> <i>With international search report. Before the expiration of the time limit for amending the claims and to be republished in the event of the receipt of amendments.</i> <b>A. O. J. P. 17 NOV 1988</b> <table border="1" data-bbox="991 987 1289 1160"><tr><td><b>AUSTRALIAN</b> <b>10 OCT 1988</b> <b>PATENT OFFICE</b></td></tr></table></p>	<b>AUSTRALIAN</b> <b>10 OCT 1988</b> <b>PATENT OFFICE</b>
<b>AUSTRALIAN</b> <b>10 OCT 1988</b> <b>PATENT OFFICE</b>			
<p>(54) Title: ALTERED ANTIBODIES</p> <p>(57) Abstract</p> <p>An antibody with an altered effector function, e.g. altered affinity for an effector ligand such as an Fc receptor (FcR) on a cell or the C1 component of complement, is produced by replacing at least one amino acid residue in the constant portion of the antibody with a different residue.</p>			

- 1 -

Title:           Altered antibodies

---

Field of invention

This invention relates to altered antibodies and concerns  
5 an antibody with an altered effector function, a method of  
producing such an antibody, and a process for altering an  
effector function of an antibody.

Background to the invention

Antibodies, or immunoglobulins, comprise two heavy chains  
10 linked together by disulphide bonds and two light chains,  
each light chain being linked to a respective heavy chain  
by disulphide bonds. The general structure of an antibody  
of class IgG (ie an immunoglobulin (Ig) of class gamma  
(G)) is shown schematically in Figure 1 of the  
15 accompanying drawings.

Each heavy chain has at one end a variable domain followed  
by a number of constant domains. Each light chain has a  
variable domain at one end and a constant domain at its  
20 other end, the light chain variable domain being aligned  
with the variable domain of the heavy chain and the light  
chain constant domain being aligned with the first  
constant domain of the heavy chain.

Antigen binds to antibodies via an antigen binding site in  
the variable domains of each pair of light and heavy  
25 chains. Other molecules, known as effector molecules,

- 2 -

bind to other sites in the remainder of the molecule, ie other than the antigen binding sites, and this portion of antibody will be referred to herein as "the constant portion" of an antibody, such sites being located  
5 particularly in the Fc region constituted by the portions of the heavy chains extending beyond the ends of the light chains.

Antibodies have several effector functions mediated by binding of effector molecules. For example, binding of  
10 the C1 component of complement to antibodies activates the complement system. Activation of complement is important in the opsonisation and lysis of cell pathogens. The activation of complement also stimulates the inflammatory response and may also be involved in autoimmune  
15 hypersensitivity. Further, antibodies bind to cells via the Fc region, with a Fc receptor site on the antibody Fc region binding to a Fc receptor (FcR) on a cell. There are a number of Fc receptors which are specific for different classes of antibody, including IgG (gamma  
20 receptors), IgE (eta receptors), IgA (alpha receptors) and IgM (mu receptors). Binding of antibody to Fc receptors on cell surfaces triggers a number of important and diverse biological responses including engulfment and destruction of antibody-coated particles, clearance of  
25 immune complexes, lysis of antibody-coated target cells by killer cells (called antibody-dependent cell-mediated cytotoxicity, or ADCC), release of inflammatory mediators, placental transfer and control of immunoglobulin production.

30 Although various Fc receptors and receptor sites have been studied to a certain extent, there is still much which is unknown about their location, structure and functioning.

- 3 -

Summary of the invention

According to one aspect of the present invention, there is provided a modified antibody of the class IgG in which at least one amino acid residue in the constant portion (as  
5 herein defined) has been replaced by a different residue, altering an effector function of the antibody as compared with unmodified antibody.

An effector function of an antibody may be altered by altering, ie enhancing or reducing, the affinity of the  
10 antibody for an effector molecule such as an Fc receptor or a complement component. Binding affinity will generally be varied by modifying the effector molecule binding site, and in this case it is appropriate to locate the site of interest and modify at least part of the site  
15 in a suitable way. It is also envisaged that an alteration in the binding site on the antibody for the effector molecule need not alter significantly the overall binding affinity but may alter the geometry of the interaction rendering the effector mechanism ineffective  
20 as in non-productive binding. It is further envisaged that an effector function may also be altered by modifying a site not directly involved in effector molecule binding, but otherwise involved in performance of the effector function.

25 By altering an effector function of an antibody it may be possible to control various aspects of the immune response, eg enhancing or suppressing various reactions of the immune system, with possible beneficial effects in diagnosis and therapy.

- 4 -

For example, it is known to use monoclonal antibodies for guided localisation of malignant lesions in patients with a number of solid tumours, such as ovarian and testicular cancer. However, their general use has been limited  
5 because several major problems such as false positive, false negative as well as non-specific localisation continue to exist. The amounts of radioiodine-labelled tumour-associated monoclonal antibody reaching their target tissues after intra-venous administration in humans  
10 are small (Epenetos et al, 1986). One problem is a high non-specific uptake in normal lymph nodes and the rapid catabolism of murine monoclonal antibodies in these studies. The use of human monoclonal antibodies may also give high backgrounds due to non-specific binding to the  
15 high affinity receptors (Fc gamma RI) of the lymphatics, liver and spleen. An altered monoclonal antibody which does not bind to this high affinity receptor may improve antibody-guided tumour localisation by enhancing specific tumour uptake of the antibody while decreasing the  
20 background due to non-specific binding to FcR.

Ideally, monoclonal antibodies used for therapy of tumours would be radiolabelled or exploit the host's own effector mechanisms. It is not yet clear which of these will be the most significant in vivo for clearance of antibody-  
25 coated target cells, but ADCC by mononuclear cells, particularly K cells, seems the most effective (Hale et al, 1985). It may be possible to produce antibodies which react only with certain types of Fc receptor; for example, modified antibodies could be produced which do  
30 not bind the high affinity Fc gamma RI of cells of the R.E.S. but, when aggregated on a surface may bind Fc gamma RII expressing cells and trigger ADCC and specifically destroy the target cell.

- 5 -

Production of a modified antibody can be carried out by any suitable technique including techniques that are well known to those skilled in the art. For example an appropriate protein sequence, eg forming part or all of a relevant constant domain, eg C<sub>H</sub>2 domain, of an antibody, and include appropriately altered residue(s) can be synthesised and then chemically joined into the appropriate place in an antibody molecule.

Preferably, however, genetic engineering techniques are used for producing an altered antibody. The presently preferred such technique comprises:

- a) preparing a first replicable expression vector including a suitable promoter operably linked to a DNA sequence which encodes at least part of an IgG heavy or light chain, eg the V<sub>H</sub>, C<sub>H</sub>1 and C<sub>H</sub>2 domains of an IgG heavy chain, the appropriate residue(s) of which have been altered;
- b) if necessary, preparing a second replicable expression vector including a suitable promoter operably linked to a DNA sequence which encodes a complementary Ig light or heavy chain;
- c) transforming a cell line with the first or both prepared vectors; and
- d) culturing said transformed cell line to produce an altered antibody.

The present invention also includes vectors used to transform the cell line, vectors used in producing the



- 6 -

transforming vectors, cell lines transformed with the transforming vectors, cell lines transformed with preparative vectors, and methods for their production.

Preferably, the cell line which is transformed to produce  
5 the antibody of altered effector function is an immortalised mammalian cell line, which is advantageously of lymphoid origin, such as a myeloma, hybridoma, trioma or quadroma cell line. The cell line may also comprise a normal lymphoid cell, such as a B-cell, which has been  
10 immortalised by transformation with a virus, such as the Epstein-Barr virus. Most preferably, the immortalised cell line is a myeloma cell line or a derivative thereof.

Although the cell line used to produce the antibody of altered effector function is preferably a mammalian cell  
15 line, any other suitable cell line, such as a bacterial cell line or a yeast cell line, may alternatively be used. In particular, it is envisaged that E. coli-derived bacterial strains could be used.

It is known that some immortalised lymphoid cell lines,  
20 such as myeloma cell lines, in their normal state secrete isolated Ig light chains. If such a cell line is transformed with the vector prepared in step a) of the process defined above, it will not be necessary to carry out step b) of the process, provided that the normally  
25 secreted chain is complementary to the chain encoded by the vector prepared in step a).

However, where the immortalised cell line does not secrete or does not secrete a complementary chain, it will be necessary to carry out step b). This step may be carried  
30 out by further manipulating the vector produced in step a)

- 7 -

so that this vector encodes not only the heavy chain but also the light chain. Alternatively, step b) is carried out by preparing a second vector which is used to transform the immortalised cell line.

The techniques by which such vectors can be produced and used to transform the immortalised cell lines are well known in the art, and do not form any part of the invention.

In the case where the immortalised cell line secretes a complementary light chain, the transformed cell line may be produced, for example, by transforming a suitable bacterial cell with the vector and then fusing the bacterial cell with the immortalised cell line by spheroplast fusion. Alternatively, the DNA may be directly introduced into the immortalised cell line by electroporation.

The DNA sequence encoding the relevant altered portion of the antibody may be prepared by oligonucleotide synthesis. Alternatively, the DNA encoding the altered portion may be prepared by primer directed oligonucleotide site-directed mutagenesis. This technique in essence involves hybridising an oligonucleotide coding for a desired mutation with a single strand of DNA containing the mutation point and using the single strand as a template for extension of the oligonucleotide to produce a strand containing the mutation. This technique, in various forms, is described by Zoller and Smith, 1982; Zoller and Smith, 1984; Norris et al., 1983; Kramer et al., 1982.

For various reasons, this technique in its simplest form

**SUBSTITUTE SHEET**

- 8 -

does not always produce a high frequency of mutation. An improved technique for introducing both single and multiple mutations in an M13 based vector has been described by Carter et al., 1985a.

- 5 The invention can be applied to antibodies of different species, eg human, rodent (mouse, rat, hamster) etc, and different class. The invention can also be applied to naturally occurring antibodies, chimeric antibodies (eg of the type disclosed in PCT/GB85/00392) or altered
- 10 antibodies altered in other ways (eg of the type disclosed in GB 2188638).

As one example, work has been carried out on IgG, to alter the binding affinity for the receptor known as Fc gamma R1.

- 15 In man, and in mouse, three Fc gamma receptors have been partially characterised: Fc gamma R1, Fc gamma RII, and FC gamma R<sub>10</sub>, and these are expressed on distinct but overlapping haematopoietic cell types (Anderson and Looney, 1986). Furthermore, these different receptors have
- 20 differing affinities for IgG subclasses. As mentioned above, binding of antibody to these receptors on cell surfaces triggers a number of important and diverse biological responses. It is not known which receptor, if any, is primarily responsible for which effect, but
- 25 evidence suggests that it is the low affinity receptors which are relevant for these physiological effects. The receptors in man and mouse have been proposed as homologues on a number of physical criteria. Cloning and sequencing of the low affinity Fc gamma RII from both
- 30 sources has confirmed this prediction (Lewis et al 1986, Ravetch et al 1986). The high affinity receptor Fc gamma

- 9 -

R1 has been studied extensively and in both man and mouse binds monomeric IgG (man = IgG1 and IgG3; mouse = IgG2a) and is found on the same cell types.

5 The Fc region of IgG comprises two constant domains, C<sub>H</sub>2 and C<sub>H</sub>3, as shown in Figure 1. As with the mouse system much effort has gone into the determination of the contribution of each of the two domains, C gamma 2 and C gamma 3, to the interaction. Isolated C<sub>H</sub>3 domains, (pFc' fragments) were reported to have no inhibitory activity on  
10 the formation of monocyte rosettes (Abramson et al 1970). But other reports have shown that this fragment was capable of inhibiting Fc gamma R1 binding (Barnett-Foster et al 1980) indicating that the C gamma 3 domain was involved in binding human Fc gamma R1. This view became  
15 predominant until Woof and colleagues demonstrated that this inhibitory activity could be removed by extensive purification of the pFc' fraction by passage over protein A and anti-L chain columns. These purified samples showed no inhibition of monomer binding (Woof et al 1984).  
20 Additionally, the ability of monoclonal antibodies directed again epitopes on the C<sub>H</sub>3 domain to interact with FcR bound antibody, but not those to epitopes on C<sub>H</sub>2, is consistent with a binding site on the C<sub>H</sub>2 domain (Partridge et al, 1986).  
25 In a comprehensive study of the high affinity receptor for human IgG on human monocytes (Fc gamma R1) Woof, Burton and colleagues also localised the binding-site to the C<sub>H</sub>2 domain of human IgG1 (Woof et al, 1984; Partridge et al, 1986). A range of IgG subclasses from different species,  
30 as well as fragments of human immunoglobulin, were tested for their ability to inhibit the interaction between human IgG and human monocytes in a direct-binding microassay.

- 10 -

IgGs were grouped into those found to exhibit tight, intermediate or weak binding to the FcR on human monocytes (Fc gamma R1). By comparison of the amino-acid sequences in these different affinity groups a potential monocyte-binding site in the hinge-link region (Leu234 -Ser239) was proposed, with possible involvement of the two beta-strands and joining bend formed by the residues Gly316 - Lys338 (Woof et al, 1986). The latter region had already been proposed as the Clq binding site (Burton et al, 1980). The human Fc gamma R1 receptor binds human IgG1 and mouse IgG2a as a monomer, but the binding of mouse IgG2b is 100-fold weaker (Woof et al, 1986). A comparison of the sequence of these proteins in the hinge-link region shows that the sequence (234 to 238) Leu-Leu-Gly-Gly-Pro in the strong binders becomes Leu-Glu-Gly-Gly-Pro in mouse gamma 2b.

In an attempt to alter the binding affinity the substitution Glu235 by Leu was made in the mouse IgG2b heavy chain. The numbering of the residues in the heavy chain is that of the EU index (see Kabat et al., 1983). The normal mouse antibody does not bind to human Fc gamma R1, but by changing residue 235 from glutamic acid to leucine, eg by site directed mutagenesis, affinity for the human Fc gamma R1 is increased by over 100-fold. The magnitude of the increase in affinity was much greater than could have been expected and suggests that single amino acid changes in this region could be used to produce altered antibodies more suited to a range of in vivo applications in man and other animals. This change does not alter other Ig binding sites such as for complement component Clq.

It should also be possible to alter the affinity of Fc

- 11 -

5 gamma R1 binding by replacing the specified residue with a residue having an inappropriate functionality on its sidechain, or by introducing a charged functional group, such as Glu or Asp, or perhaps an aromatic non-polar residue such as Phe, Tyr or Trp.

10 These changes would be expected to apply equally to the murine, human and rat systems given the sequence homology between the different immunoglobulins. It has been shown that in human IgG3, which binds to the human Fc gamma R1 receptor, changing Leu 235 to Glu destroys the interaction of the mutant for the receptor. The binding site for this receptor can thus be switched on or switched off.

15 Mutations on adjacent or close sites in the hinge link region (eg replacing residues 234, 236 or 237 by Ala) indicate that alterations in residues 234, 235, 236 and 237 at least affect affinity for the Fc gamma R1 receptor.

20 Hence in a further aspect of the present invention provides a modified antibody of the class IgG having an altered Fc region with altered binding affinity for Fc gamma R1 as compared with the unmodified antibody.

Such an antibody conveniently has a modification at residue 234, 235, 236 or 237.

25 Affinity for other Fc receptors can be altered by a similar approach, for controlling the immune response in different ways.

As a further example, work has also been carried out to alter the lytic properties of Ig following binding of the

- 12 -

Cl component of complement.

The first component of the complement system, Cl, actually comprises three proteins known as Clq,Clr and Cls which bind tightly together. It has been shown that Clq is  
5 responsible for binding the three protein complex to Ig.

It has been shown that isolated Fc fragment inhibits the interaction of Clq with an Ig (Yasmeen eg al., 1976).

It has also been shown that the binding of Clq is dependent on ionic strength, suggesting that ionic  
10 interactions are involved.

It is possible to cleave the C<sub>H</sub>3 domain from the remainder of an Ig molecule, and it has been shown that deletion of the C<sub>H</sub>3 domain does not abolish Clq binding activity (Colomb and Porter, 1975).

15 It is also possible to isolate the C<sub>H</sub>2 domain from Igs. It has been shown that such isolated C<sub>H</sub>2 domains have the same binding affinity for Clq as do isolated Fc fragments (Isenman et al., 1975).

From this, it has been inferred that the binding site for  
20 Clq is located in the C<sub>H</sub>2 domain of the Ig. Various attempts have been made to identify the particular amino acid residues in the C<sub>H</sub>2 domain involved in Clq binding. In a first approach, synthetic peptides corresponding to short sections of the C<sub>H</sub>2 domain were tested for  
25 inhibition of Clq binding. This identified two possible binding sites (Boakle et al., 1975 and Lukas et al., 1981).

- 13 -

In a second approach, a comparison of the sequences of several Ig C<sub>H</sub>2 domains was made in conjunction with studies of their three dimensional structure. This led to the identification of two further proposals for the site  
5 of Clq binding (Brunhouse and Cebra, 1979 and Burton et al., 1980).

It has now been found that the Clq binding activity of an antibody can be altered by providing the antibody with an altered C<sub>H</sub>2 domain in which at least one of the amino acid  
10 residues 318, 320 and 322 of the heavy chain has been changed to a residue having a different side chain.

The numbering of the residues in the heavy chain is that of the EU index (see Kabat et al., 1983).

The present inventors have discovered that, in a specific Clq-binding Ig referred to below, by changing any one of  
15 residues 318 (Glu), 320 (Lys) and 322 (Lys), to Ala, it is possible to abolish Clq binding.

Moreover, by making mutations at these residues, it has been shown that Clq binding is retained as long as residue  
20 318 has a hydrogen-bonding side chain and residues 320 and 322 both have a positively charged side chain.

The Applicants believe that these three residues are probably involved directly in the binding Clq to IgG. However, it is also possible that these residues are not directly involved in physical contact with Clq. These  
25 residues may help one C<sub>H</sub>2 domain to pack against an adjacent domain in an IgG aggregate, thus producing the at least two molecules of IgG together which are required for Clq binding. If this is the case, the Clq may be in



- 14 -

direct contact with the IgG in an entirely different area. The Applicants, however, do not wish to be in any way limited to either of these theories.

Altering residue 333 (Glu), which is close to the three  
5 specified residues, or residue 253 (Ile), which is distant from the three specified residues, does not alter Clq binding activity, even though previous studies have implicated residue 333 (Glu) in Clq binding.

It is to be noted that residues 318, 320 and 322 are  
10 highly conserved in mouse and human IgGs which are complement binding.

It has also been shown that alteration of the three specified residues only alters the Clq binding activity, and does not alter antigen binding activity, protein A  
15 binding activity (protein A binds to the  $C_{H2}/C_{H3}$  interface), or the ability of the Fc to bind to mouse macrophages.

It is believed that the process of the present invention can be used to abolish Clq binding activity by replacing  
20 any one of the three specified residues with a residue having an inappropriate functionality on its side chain. It is not necessary to replace the ionic residues only with Ala to abolish Clq binding. It will also be possible to use other alkyl-substituted non-ionic residues, such as  
25 Gly, Ile, Leu, or Val, or such aromatic non-polar residues as Phe, Tyr, Trp and Pro in place of any one of the three residues in order to abolish Clq binding. It will also be possible to use such polar non-ionic residues as Ser, Thr, Cys,  
30 318, and Met in place of residues 320 and 322, but not in order to abolish Clq binding activity.

- 15 -

It may be that the side chains on ionic or non-ionic polar residues will be able to form hydrogen bonds in a similar manner to the bonds formed by the Glu residue. Therefore, replacement of the 318 (Glu) residue by a polar residue  
5 may modify but not abolish Clq binding activity.

It has further been shown that replacing residue 297 (Asn) with Ala results in removal of lytic activity while only slightly reducing (about three fold weaker) affinity for Clq. It is thought this is because the alteration  
10 destroys the glycosylation site and that the presence of carbohydrate is required for complement activation. Any other substitution at this site will also destroy the glycosylation site.

Further, the mutation Lys 320 to Gln has an affinity for  
15 Clq only slightly weaker than the wild type but is non lytic. This indicates that good Clq binding may be insufficient for lysis and that perhaps a precise orientation of Clq is required.

All antibody isotypes sequenced to date possess the Clq  
20 binding motif, or a closely related motif which is effective in binding Clq when it is transplanted into the mouse IgG2b antibody. Clearly there must be further determinants for lysis. For example, antibody isotypes with short hinges and low segmental flexibility are non-  
25 lytic (Oi et al. 1984) suggesting that (a) the interaction of Clq with the motif may be sterically blocked due to close approach of the Fc by the Fab arms (Leatherbarrow et al., 1985) or (b) the interaction of Clq and antibody requires an exact alignment for lysis and therefore  
30 requires some flexibility per se.

- 16 -

The present invention is now described, by way of example only, with reference to the accompanying drawings, in which:-

Figure 1 illustrates the structure of an Ig;

- 5 Figure 2 illustrates the sequence of cloning steps used to produce an antibody of altered Fc gamma R1 binding activity;

Figure 3 shows the sequence of mouse IgG gamma 2b gene;

- 10 Figure 4 is a graph illustrating inhibition of  $^{125}\text{I}$ -labelled pooled human IgG binding to high affinity receptors on U937 cells by mouse gamma 2b immunoglobulins;

Figure 5 is a Scatchard plot of  $^{125}\text{I}$ -EL235 binding to U937 high affinity receptors;

- 15 Figure 6 shows the nucleotide sequence and protein sequence of the human gamma 3 gene; and

20 Figure 7 shows the nucleotide sequence encoding the  $\text{C}_{\text{H}}2$  domain of mouse IgG2b antibody with mutants and the sequences of the oligonucleotides used to construct some of the mutants referred to below.

The following concerns experiments on mouse IgG2b to alter the affinity thereof for human Fc gamma R1.

DNA encoding the variable and constant region exons of antibodies can be manipulated in vitro and reintroduced

- 17 -

into lymphoid cell lines (Neuberger, 1985). Using vectors based on pSV-gpt (Mulligan & Berg 1981) and the Ig heavy chain promoter/enhancer, antibodies can be expressed and secreted. One such vector, pSV-VNP 2b (Neuberger and Williams 1985) encodes a variable domain which binds nitrophenylacetyl (NP) and the constant domains of the natural mouse IgG2b antibody. The antibody produced using this vector does not bind to human Fc gamma R1.

Part of the structure of the pSV-VNP 2b vector is shown in Figure 2(a). The vector was partially digested with SacI and a fragment containing both the C<sub>H</sub>2 and C<sub>H</sub>3 domains was cloned into plasmid M13K19 (Carter et al, 1985a) as shown in Figure 2(b).

The SacI site at the N-terminal end of the C<sub>H</sub>3 domain was removed by site directed mutagenesis with an oligonucleotide which retains the amino acid sequence at this N-terminal end.

A point mutation in the C<sub>H</sub>2 domain was then produced using a synthetic oligonucleotide as shown in Figure 3, in the region indicated between bases 956 and 975 and marked EL235. Further details of the construction of the mutation is given below. The mechanism of the point mutation is shown in Figure 2(c).

The mutant C<sub>H</sub>2-C<sub>H</sub>3 fragments were recloned into the pSV-VNP 2b vector to replace the wild type C<sub>H</sub>2-C<sub>H</sub>3 domains. The mutant pSV-VNP 2b vectors were incorporated into J558L, cultured to produce antibody and the antibody mutant known as EL235 was purified on NIP-Sepharose.

Construction of mutations in the C gamma 2 exon

- 18 -

Mutations were constructed in the M13B19-C gamma 2/C gamma 3 as in Carter et al (1985a). The principles and methods are described in detail in Carter et al, (1985b), and Duncan.

5 The mutant EL235 was assayed by inhibition of binding of human IgG as well as by direct binding to a human monocyte cell line (Woof et al, 1984; 1986). Inhibition of binding of monomeric  $^{125}\text{I}$ -labelled normal pooled human IgG to high affinity Fc receptors on a human monocyte cell line, U937, was measured in a quantitative microassay system in which free and cell-bound label were separated by centrifugation through a water-immiscible oil. The binding of wild-type gamma 2b and the mutant EL235 were compared by competition of labelled polyclonal human IgG. Figure 4 shows the inhibition curves for this experiment. In Figure 4 empty circles represent wild type and solid circles mutant EL235. The result has been normalised such that the fractional binding of  $^{125}\text{I}$ -IgG = 1 in the absence of inhibitors. The mutant inhibits the binding of human IgG1; the wild type protein showed no inhibitory activity. Direct binding of radiolabelled mutant EL235 to U937 cells gives a binding constant of  $3.13 \times 10^8 \text{ M}^{-1}$  (Figure 5), very similar to the value for pooled human IgG in the same experiment.

25 Figure 5 is a typical Scatchard plot of  $^{125}\text{I}$ -EL235 binding to U937 high affinity FC receptors. The number of moles of  $^{125}\text{I}$ -EL235 bound per mole of cells,  $r$ , was calculated using the following relationship:-

$$r = \frac{6 \times 10^{23} \times \text{IgG2b}}{\text{no. cells/L}}$$

- 19 -

where  $IgG_{2b}$  is the concentration of bound  $^{125}I$ -EL235.  $A$  represents the concentration of free  $^{125}I$ -EL235. The coefficient of correlation of the plot was 0.95.

Thus a point mutation altered the binding affinity of mouse  $IgG_{2b}$  for human Fc gamma R1 by greater than 100-fold.

Mutations were made in the human gamma 3 gene (Huck et al., 1985); the Hind III - SpHI fragment was first subcloned into M13 mp19 after attaching BamHI linkers. Then synthetic oligonucleotides were used as described previously to make the mutations:

234 Leu to Ala  
235 Leu to Glu  
236 Gly to Ala  
15 237 Gly to Ala

as indicated on Figure 6.

The BamHI fragment was attached to a Hind III - BamHI fragment encoding the variable domain of the B18 antibody (as in Neuberger et al., 1984 and 1985) and cloned for expression into a pSVgpt vector.

The properties of the recombinant antibodies in binding in Fc gamma R1 were determined indirectly in a competition assay as described in connection with Figure 4. Table 1 shows the concentration of antibody required to inhibit the binding of  $^{125}I$  labelled pooled human IgG to U937 cells.

Table 1

	<u>I<sub>50</sub> (M)</u>
Wild type (Leu 234, Leu 235, Gly 236, Gly 237)	10 <sup>-8</sup>
5 Mutants	
Ala 234	4 x 10 <sup>-8</sup>
Glu 235	greater than 10 <sup>-6</sup>
Ala 236	3 x 10 <sup>-8</sup>
Aia 237	3 x 10 <sup>-7</sup>

10 The table gives the approximate values of I<sub>50</sub> (ie the concentration of IgG3 at which the fractional binding of <sup>125</sup>I labelled pooled human IgG is 0.5).

15 These findings have important implications for the use of antibodies, both murine and human, in diagnostics and therapy, as discussed above.

The present results show that Fc gamma R1 receptor can be selectively switched on or off, and this might be of great use in the preparation of antibodies for in vivo diagnosis or therapy of humans as well as other animals.

20 Similar experiments were carried out at mouse IgG2b to alter lytic activity following binding of Clq. Further mutants of the pSV-VNP 2b vector were produced using the procedure described above, with point mutations being

- 21 -

produced in the C<sub>H</sub>2 domain using synthetic oligonucleotides as shown in Figure 7, and antibodies produced as previously described.

5 Antibody produced using the pSV-VNP 2b vector, with wild type C<sub>H</sub>2-C<sub>H</sub>3 domains binds Clq (see Table 2).

10 The ability of the resulting purified antibodies to lyse specifically NIP-kephalin derivatised sheep red blood cells (Weltzien et al., 1984) was tested in a quantitative haemolysis microassay (Young et al., 1986). The results of the test are shown in Table 2. The titre in ug/ml antibody represents the amount of antibody required for 50% lysis after 30 minutes at 37°C.

15 A number of the mutant antibodies were tested for affinity for radiolabbed Clq (Leatherbarrow and Dwek, 1984) after aggregating the anti-NP antibodies on NP-Affigel. The results are shown also in Table 2.



- 22 -

Table 2

	IgG	titre (ug/ml)	Affinity nM
	MolgG2b	3	10
	MolgM	0.15	-
5	MolgG1	X	-

## Irrelevant Mutations of MolgG2b

	Pro 331 - Ala	3	-
	Pro 331 - Gly	-	12
	Glu 333 - Ala	3	12
10	Thr 335 - Ala	3	10
	Ser 337 - Ala	3	11
	Glu 283 - Ala	3	-
	His 285 - Ala	3	12
	His 290 - Ala	3	11
15	Glu 294 - Ala	3	-
	Glu 235 - Ala	3	-
	Lys 248 - Ala	3	-
	Ile 253 - Ala	3	9
	Ser 267 - Ala	3	-
20	Asp 270 - Ala	3	-
	Gln 274 - Ala	3	-
	Lys 317 - Ala	3	-
	Lys 236 - Ala	3	-
	Lys 340 - Ala	3	-

- 23 -

## Mutations of MolgG2b which abolish lytic activity

	Glu 318 - Val	x	-
	Glu 318 - Ala	x	greater than 300
	Lys 320 - Ala	x	greater than 300
5	Lys 320 - Gln	x	13
	Lys 322 - Ala	x	greater than 300
	Lys 322 - Gln	x	-
	Asn 297 - Ala	x	31

## Mutations of MolgG2b which conserve lytic activity

10	Glu 318 - Thr	3	12
	Lys 320 - Arg	3	11
	Lys 322 - Arg	3	11

15 Antibodies with the  $V_{NP}$  domain attached to human IgG1 and mouse IgG1 were kindly supplied by Dr M Bruggemann and Mr P T Jones respectively.

20 Mutants Glu318-Ala, Lys320-Ala and Lys322-Ala have a dramatically reduced affinity (Table 2). However, they retain binding for the NP hapten and protein A (which binds at the  $C_{H2}-C_{H3}$  interface). This suggests that the loss of Clq binding is not due to major structural change in the antibody. Mutations in adjacent residues (Glu333-Ala) or distant residues (Ile253-Ala) retain Clq affinity.

- 24 -

The results suggest that a surface patch defined by the side chains of residues 318, 320 and 322 determine whether an IgG will interact with Clq. These residues are highly conserved in human and mouse IgGs, indicating that alterations of side chains at these three locations can be used to construct therapeutically useful variants of human C<sub>H</sub>2 domains which do not activate complement, or which have an enhanced affinity for complement.

Evidence that this surface patch is the complete binding site for Clq comes from a polypeptide mimic containing the Glu X Lys X Lys motif which proved to inhibit Clq lysis in a model system. This work is described in a copending PCT application No. \_\_\_\_\_ of Research Corporation entitled "Complement Binding Peptide" filed on the same date as this application.

It will be appreciated that the present invention has been described above purely by way of illustration and that variations and modifications can be made without departing from the scope of the invention.

REFERENCES

- Abramson, N., Gelfand, E.W., Jandl, J.H., and Rosen, F.S.  
(1970) J. Exp. Med. 132, 1207.
- Anderson, C.L., and Looney R.J. (1986) Immunol. Today, 7,  
5 264.
- Barnett-Foster, D.E., Dorrington, K.J., and Painter, R.H.  
(1980) J. Immunol. 124, 2186
- Boakle et al., (1975) Nature, 282, 742-743
- Brunhouse and Cebra, (1979) Molec. Immun., 16, 907-917.
- 10 Burton et al., (1980) Nature, 288, 338-344.
- Burton, D.R. (1985) Molec. Immunol. 22, 161.
- Burton, D.R., Boyd, J., Brampton, A., Easterbrook-Smith,  
S., Emanuel, E.J., Novotny, J., Rademacher, T.W., van  
Schravendijk, .R., Sternberg, M.J.E., and Dwet, R.A.  
15 (1980) Nature 288, 338.
- Carter, P., Bedouelle, H., and Winter, G. (1985a) Nucleic  
Acids Res. 13, 4431-4443.
- Carter, P., Bedouelle, H., Waye, M.Y., and Winter, G.  
(1985b) In: Oligonucleotide-site-directed mutagenesis in  
20 M13. Anglian Biotechnology Limited, Colchester, England.
- Colomb and Porter (1975) Biochem J., 145, 177-183.

- 26 -

Duncan A.R., University of Cambridge Phd Thesis (to be published).

Epenetos, A., Snook, D., Durbin, H., Johnson, P., and Tayler-Papadimitriou, J. (1986) *Cancer Res*, 46,3183.

- 5 Hale, G., Clark, M., and Waldmann, H. (1985) *J. Immunol.* 1134, 3056.

Hale, G., and Waldmann, H. (1985) in *Hybridoma Technology in the Biosciences and Medicine*. T. Springer, ed. Plenum Press, New York.

- 10 Huber, H., and Fudenberg, H.H. (1968) *Int. Arch. Allergy Appl. Immunol.* 34, 18.

Huck et al., (1985) *Nuc. Acids Res* 14, 1779-1788.

Isenman et al., (1975) *J. Immun.*, 114, 1726-1729.

- 15 Kabat et al., (1983) "Sequences of Proteins of Immunological Interest", US Dept. Health and Human Services.

Kalofonos, H.P., and Epenetos, A. (1986) *Cancer Treatment Renewals* 13,243.

Kramer et al., (1982) *Nuc. Acides Res.*, 10, 6475-6485.

- 20 Leatherbarrow and Dweck (1984) *Molec Immun.*, 21, 321-327.

Leatherbarrow, R.J., Rademacher, T.W., Dwek, R.A., Woof, J.M., Clark, A., Burton, D.R., Richardson, N., and Feinstein, A. (1985) *Molec, Immun.* 22,407-415.

- 27 -

Lewis, V.A., Koch, T., Plutner, H., and Mellman, I.  
(1986) Nature 324, 372.

Lukas et al., (1981) J. Immun., 127, 2555-2560.

5 Mulligan, R.C., and Berg, P. (1981) Proc. Natl. Acad.  
Sci. USA 78, 2072.

Neuberger, M.S., and Williams, G.T. (1986) Phil. Trans.  
R. Soc. Lond. A 317, 425-432.

10 Neuberger, M.S., Williams, G.T., Mitchell, E.B., Jouhal,  
S.S., Flanagan, J.G., and Rabbitts, T.H. (1985) Nature  
314, 268.

Neuberger, M.S., Williams, G. T. and Fox, R.O. (1984)  
Nature, 312, 604-608

Norris et al., (1983) Nuc. Acids Res., 11, 5103-5112.

15 Oi, V.T., Minh-Vuong, T., Hardy, R.R., Reidler, J., Dangl,  
J.L., Herzenberg L.A. and Stryer (1984) Nature, 307, 136-  
140.

Partridge, L.J., Woof, J.M., Jefferis, R., and Burton,  
D.R. (1986) Molec. Immunol. 23, 1365.

20 Ravetch, J.V., Luster, A.D., Weinshank, R., Kochan, A.,  
Pavlovec, D.A., Portnoy, J., Hulmes, J., Pan, Y.M.C.,  
Unkeless, J. (1986) Science 234, 718.

Suggs, S.V., Hirose, T., Miyake, T., Kawashima, E.H.,

- 28 -

Johnson, M.J., Itakura, K., and Wallace, R.B. (1981) In: Developmental Biology using Purified Genes (D. Brown, ed.) Academic Press, New York.

Weltzien et al., (1984) Molec. Immunol., 21 801.

- 5 Woof, J.M., Jafaar, M.I., Jefferis, R., and Burton, D.R. (1984) Molec. Immun. 21, 523.

Woof, J.M., Partridge, L.J., Jefferis, R., and Burton D.R. (1986) Molec. Immun. 23, 319.

Yasmeen et al., (1976) J. Immun., 116, 518-522.

- 10 Young et al., (1986) Anal. Biochem., 154, 649-654.

Zoller and Smith (1982) Nuc. Acids Res., 10, 6487-650.

Zoller and Smith (1984) DNA, 3, 497-488.

CLAIMS

1. A modified antibody of the class IgG in which at least one amino acid residue in the constant portion (as herein defined) has been replaced by a different residue altering  
5 an effector function of the antibody as compared with unmodified antibody.
2. An antibody according to claim 1, wherein the antibody has altered affinity for an effector molecule as compared with unmodified antibody.
- 10 3. An antibody according to claim 1, wherein the antibody is a natural antibody, a chimeric antibody or an altered antibody.
4. A modified antibody of the class IgG having an altered Fc region with altered binding affinity for an Fc receptor  
15 as compared with unmodified antibody.
5. A modified antibody of the class IgG having an altered Fc region with altered binding affinity for Fc gamma R1 receptor as compared with unmodified antibody.
6. An antibody according to claim 5, wherein at least one  
20 of the amino acid residues 234, 235, 236 and 237 of the heavy chain has been replaced by a different residue(s).
7. An antibody according to claim 6, wherein residue 235 has been replaced by Glu.



- 30 -

8. An antibody according to claim 6, wherein at least one of residues 234, 236 and 237 has been replaced by Ala.
9. A modified antibody of the class IgG having an altered Fc region with altered binding affinity for Clq as  
5 compared with unmodified antibody.
10. An antibody according to claim 9, having an altered C<sub>H</sub>2 domain in which at least one of the amino acid residues 318, 320 and 322 of the heavy chain has been changed to a residue having a different side chain.
- 10 11. An antibody according to claim 10, wherein at least one of the residues 318, 320 and 322 has been changed to Ala, reducing Clq binding affinity.
12. An antibody according to claim 10, wherein residue 318 has been changed to Val.
- 15 13. An antibody according to claim 10, wherein residue 322 has been changed to Gln.
14. A modified antibody of the class IgG having an altered Fc region with altered lytic properties as compared with unmodified antibody.
- 20 15. An antibody according to claim 15, having an altered C<sub>H</sub>2 domain in which amino acid residue 297 of the heavy chain has been altered.
16. An antibody according to claim 15, where residue 297 has been replaced by Ala.

- 31 -

17. An antibody according to claim 1, comprising rodent or human IgG.

18. A process for altering an effector function of an antibody of the class IgG for an effector molecule,  
5 comprising replacing at least one amino acid residue in the constant portion (as herein defined) with a different residue, altering an effector function of the antibody as compared with unmodified antibody.

19. A method of producing a modified antibody of the  
10 class IgG with an altered effector function as compared with unmodified antibody, comprising:-

a) preparing a first replicable expression vector including a suitable promoter operably linked to a DNA  
15 sequence which encodes at least part of the constant portion of an Ig heavy or light chain and in which at least one amino acid residue differs from the corresponding residue(s) in unmodified antibody;

b) if necessary, preparing a second replicable expression vector including a suitable promoter operably linked to a  
20 DNA sequence which encodes a complementary Ig light or heavy chain;

c) transforming a cell line with the first or both prepared vectors; and

d) culturing said transformed cell line to produce a  
25 modified antibody.

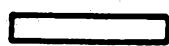
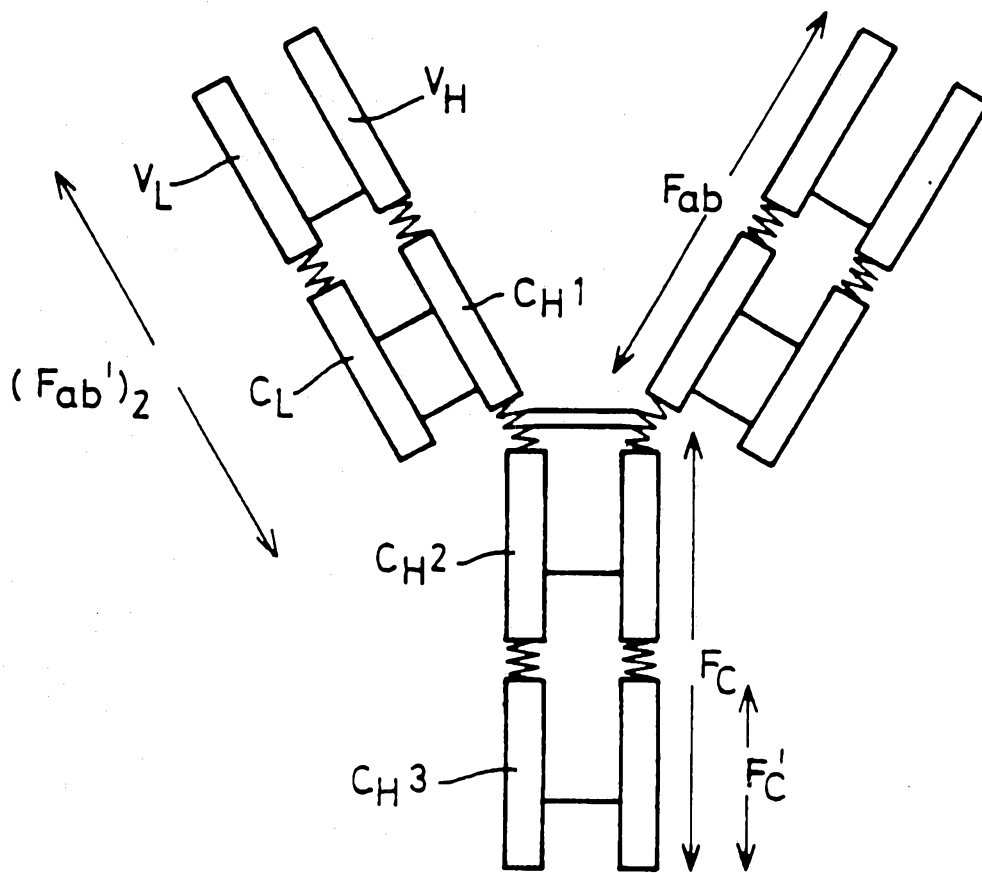

V

C

L

H

domains

inter-domain sections

disulphide bonds

variable

constant

light chain

heavy chain

Fig.1

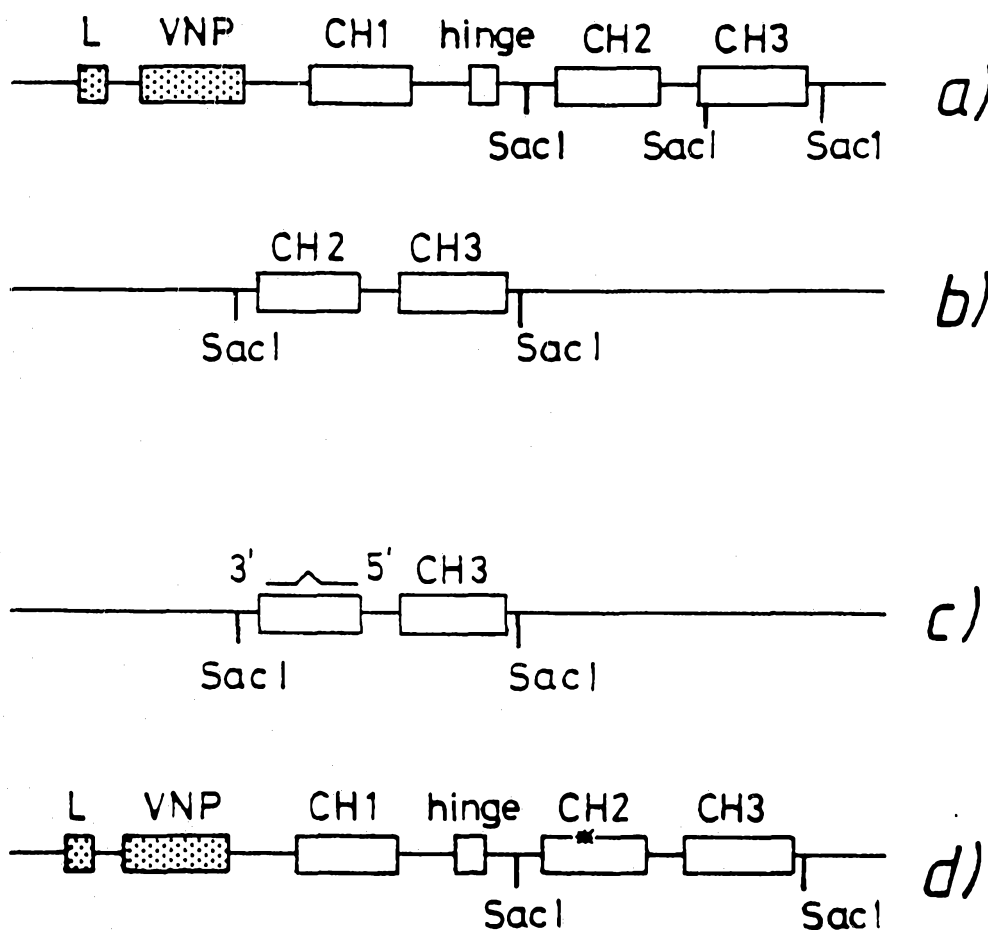

Fig. 2

AACATGGAAAAATTAAGGTCACAGTGCAAGCTCTGGAGGCGGAAATTTCTGACACTGCTTGCCTCAGATCAATTGTAGAAGACACGGTTCTAAGAGCAAAGCTAAGAACAGAATCTCTCC  
10 20 30 40 50 60 70 80 90 100 110 120

CHI domain

A K T T P P S V Y P L A P G C G D T T G S S V

AAATATCCGAGGCCACTGATAAGAAAAAGCTCACACATTCTCCTCTCTTGAGCCAAAACAACACCCCATCAGTCTATCCACTGGCCCTGGGTGTGGAGATACTGGTTCCCTCCGT  
130 140 150 160 170 180 190 200 210 220 230 240

T L G C L V K G Y F P E S V T V T W N S G S L S S S V H T F P A L L Q S G L Y T  
GACTCTGGGATGCCCTGGTCAAGGGCTACTTCCCTGAGTCAGTGACTGTGACTTGGAACTCTGGATCCCTGTCCAGCAGTGTGCACACCTTCCCAGCTCTCTGCACTCTGGACTCTACAC  
250 260 270 280 290 300 310 320 330 340 350 360

M S S S V T V P S S T W P S Q T V T C S V A H P A S S T T V D K K L  
TATGAGCAGCTCAGTGACTGTCCCCTCCAGCACTTGGCCAAGTCAGACCGTACCTGCAGCGTTGCTCACCCAGCCAGCAGCACCACGGTGGACAAAAAAGCTGGTGAGAGGACATTCAG  
370 380 390 400 410 420 430 440 450 460 470 480

GGGAGGAGGGATTACACAGAGTTGAGGC...AAGGTATTAGCCTATCTAAACCAGCCAGGCTGGGATCCATACCAAGGAGGTGACCTTAGCCCAGGGAAGAGGGAGATACTGTCTCTGCCT  
490 500 510 520 530 540 550 560 570 580 590 600

3/8

CCCTCCTGGGAACATCTAGCTATGACCACCTACACTCAAGGACATGTTCTCTGGGATAGGTGTGCTTGTCAATTCAGGATCATCCTGGAACCTAAGCCCATACCAGGACAACTTTCCT  
610 620 630 640 650 660 670 680 690 700 710 720

hinge

E P S G P I S T I N P C P P C K E C H K C

CTCTCTGGTTGGTGTCTCTCTCTCTCAAAAACAGTAACATCCAGCCTTCTCTCTGCAGAGCCAGCGGGCCATTTCAACAATCAACCCCTGTCTCCATGCAAGGAGTGCACAAT  
730 740 750 760 770 780 790 800 810 820 830 840

CH2 domain

A P N

P  
GCCCAGGTAAGTCACTACCA[AGCT]CACTCCCAGGAGAATGGTAAGTGTGTAATAATCCCTGTAATGGAGGATAAGCCATGTACAAATCCATTTCCATCTCTCCTCATCAGTCTCCTAA  
850 860 870 880 890 900 910 920 930 940 950 960

3' GGATT

L [E] G G P S V F I F P P N I K D V L M I S L T P K V T C V V V D V S E D D P D V  
CCTCGAGGGTGGACCATCCGTCTCATCTTCCCTCAAATATCAAGGATGTACTCATGATCTCCCTGACACCAAGGTACAGTGTGTGGTGGTGGATGTGAGCGAGGATGACCCAGACGT  
970 980 990 1000 1010 1020 1030 1040 1050 1060 1070 1080

\*\*  
GGAGGACCCACCTGG oligo EL235

Fig. 3A

NUCLEOTIDE SHEET

Q I S W F V N N V E V H T A Q T Q T H R E D Y N S T I R V V S T L P I Q H Q D W  
 CCAGATCAGCTGGTTTGTGAACAACGTGGAAGTACACACAGCTCAGACACAAACCCATAGAGAGGATTACAACAGTACTATCCGGGTGGTCAGCACCCCTCCCCATCCAGCACCAGGACTG  
 1090 1100 1110 1120 1130 1140 1150 1160 1170 1180 1190 1200

M S G K E F K C K V N N K D L P S P I E R T I S K I K  
 GATGAGTGGCAAGGAGTTCAAATGCAAGGTCAACAACAAGACCTCCCATCACCCATCGAGAGAACCATCTCAAAAATTAAAGGTGGGACCTGCAGGACAACCTGCATGGGGGCTGGGATG  
 1210 1220 1230 1240 1250 1260 1270 1280 1290 1300 1310 1320

(CH3 domain SacI (removed))

G L V R A P Q V Y I L P P P A E  
 GGCATAAGAATAAATGTCTATGTGGACAGCCTTCCACTTCAGCCATGACCTCTATGTATGTTTCTAACCCACAGGGCTAGTCAAGCTGCACAAGTATACATCTTGCCGCCACCAGCAG  
 1330 1340 1350 1360 1370 1380 1390 1400 1410 1420 1430 1440

Q L S R K D V S L T C L V V G F N P G D I S V E W T S N G H T E E N Y K D T A P  
 AGCAGTTGTCCAGGAAAGATGTCAGTCTCACTTGCCTGGTCGTGGGCTTCAACCCTGGAGACATCAGTGTGGAGTGGACCAGCAATGGGCATACAGAGGAGAACTACAAGGACACCCGCAC  
 1450 1460 1470 1480 1490 1500 1510 1520 1530 1540 1550 1560

V L D S D G S Y F I Y S K L N M K T S K W E K T D S F S C N V R H E G L K N Y Y  
 CAGTCTAGACTCTGACGGTTCTTACTTCATATATAGCAAGCTCAATATGAAAACAAGCAAGTGGGAGAAAACAGATTCCTTCTCATGCAACGTGAGACACGAGGGTCTGAAAAATTACT  
 1570 1580 1590 1600 1610 1620 1630 1640 1650 1660 1670 1680

SacI

L K K T I S R S P G K \*  
 ACCTGAAGAAGACCATCTCCCGGTCTCCGGGTAATGAGCTCAGCACCCACAAAGCTCTCAGGTCTTAAGAGACTGGCACCCATATCCATGCATCCCTTGTATAAATAAAGCATCCAG  
 1690 1700 1710 1720 1730 1740 1750 1760 1770 1780 1790 1800

CAAAGCCTGGTACCATGTAAAACCTGTCTGGTTCTTTCCAAGGTATAGAGCATAGCTCACGGGCTGATAGGTCTGGCCAGGGCCGGAGAACAGCCTTGTCATAGGAAGAGAAATGAGGTT  
 1810 1820 1830 1840 1850 1860 1870 1880 1890 1900 1910 1920

TCTGCCTGCAT  
 1930

SUBSTITUTE SHEET

4/8

Fig. 3B

5/8

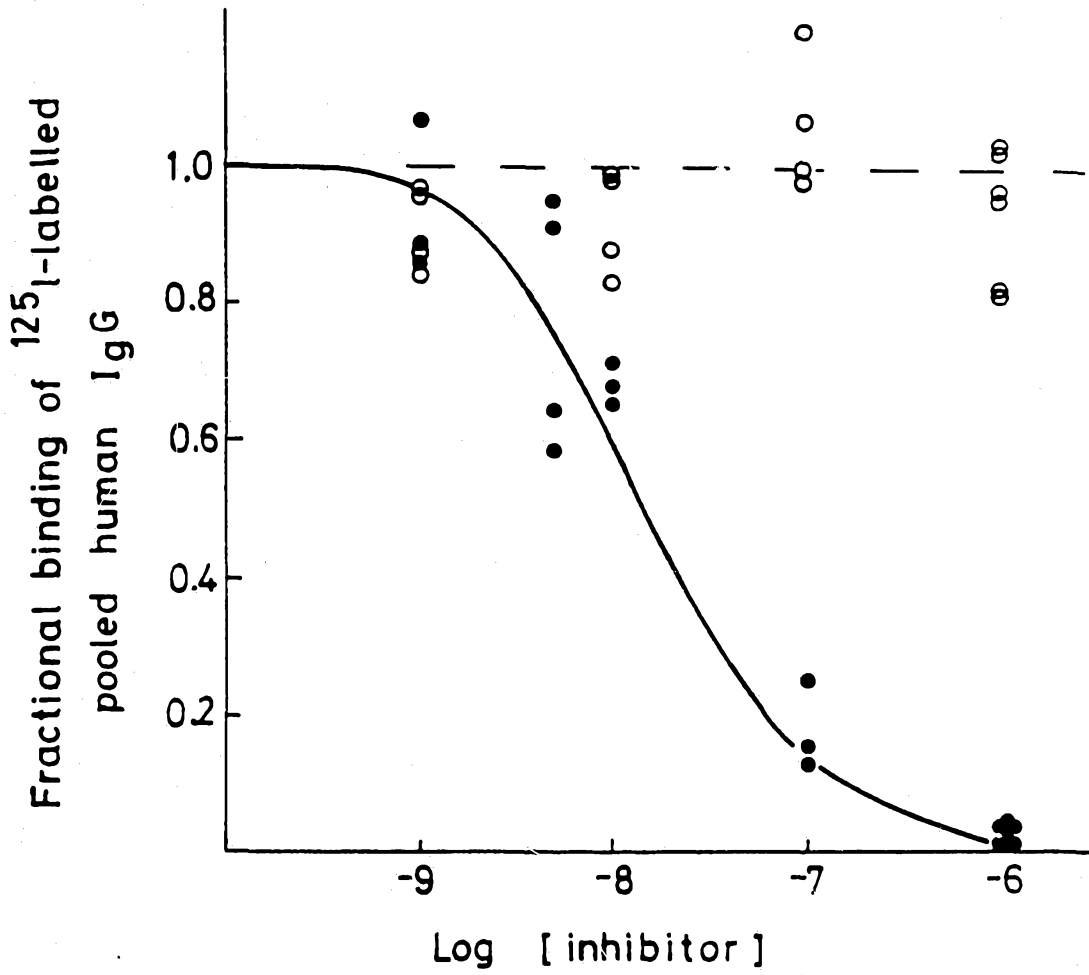

Fig.4

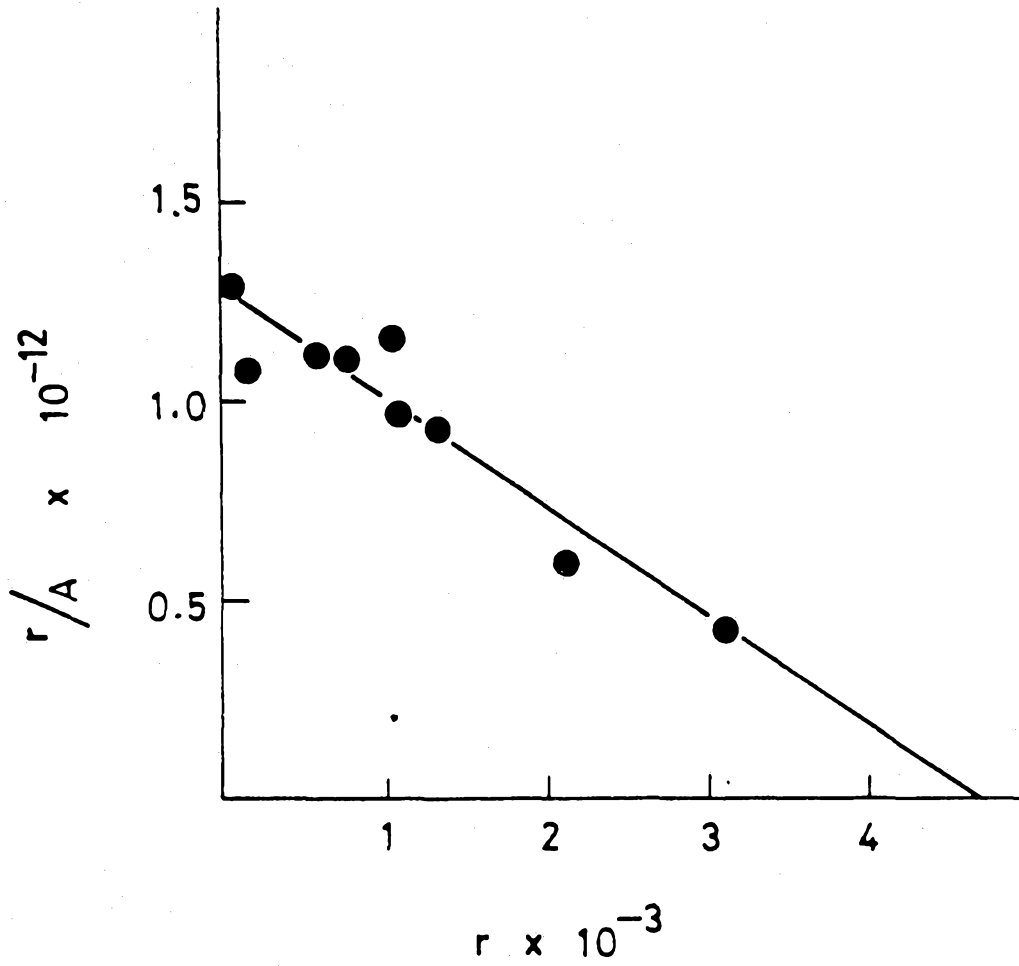
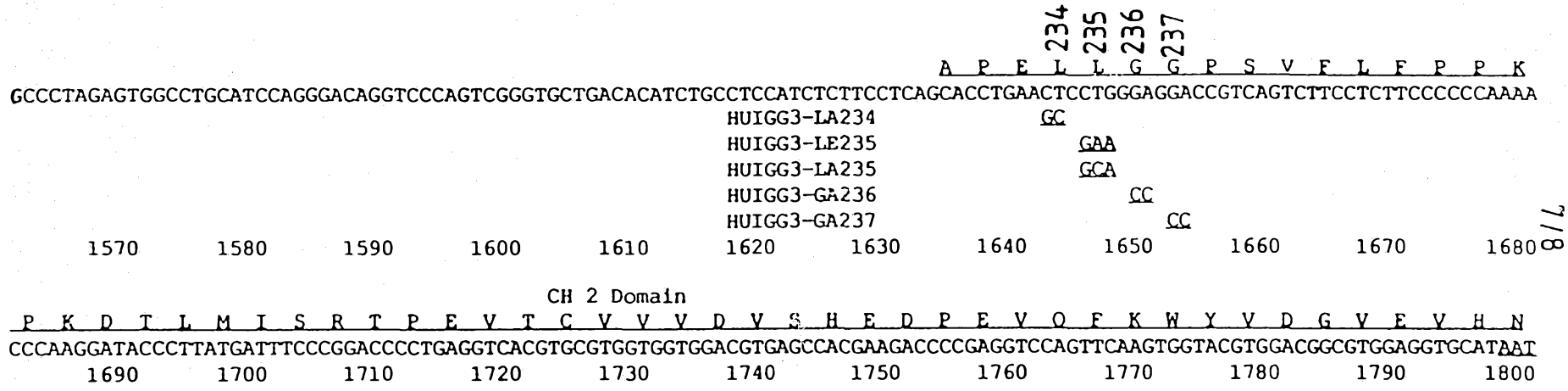

Fig. 5





234  
235  
236  
237

R  
GAA  
GCA  
CC  
CC

7/8

Fig. 6

CCCTGTRATGGAGGATAAGCCATGTACAAATCCATTTCCATCTCTCCTCATCAGCTCCTA <sup>A P N</sup>

253

L E G G P S U F I F P P N I K D U L M I  
ACCTCGAGGGTGGACCATCCGTCTTCATCTTCCCTCCRAATATCAGGATGTACTCATGA  
3' ATGACTACC

S L T P K U T C U U U D U S E D D P D U  
TCTCCCTGACACCCAGGTCAAGTGTGTGGTGGTGGATGTAGCGAGGATGACCCAGACG  
GGAGGGACT 5' Ile253-Ala

Q I S W F U N N U E U H T A Q T Q T H R  
TCCAGATCAGCTGGTTTGTGAACAACGTGGAAGTACACACAGCTCAGACACAAACCCATA

297

E D Y N S T I R U U S T L P I Q H Q D W  
GAGAGGATTACAACAGTACTATCCGGGTGGTCAGCACCCCTCCCCATCCAGCACCCAGGACT  
3' TCCTAATGCGGTCATGAT 5' Asn297-Ala

318

320

322

333

M S G K E F K C K U N N K D L P S P I E  
GGATGAGTGGCAAGGAGTTCRAATGCAAGGTCAACACRAAGACCTCCCATCACCCATCG  
3' CACCGTTCGGGAGT 5' Glu318-Ala 3' TGGGTAGC

3' CCTCAGCGGACGTTC 5' Lys320-Ala

3' TTACGCGGCAGTTG 5' Lys322-Ala

337

R T I S K I K  
AGAGAACCATCTCAAAAATTAAGGTGGGACCTGCAGGACA  
GGTCTT 5' Glu333-Ala

3' GGTAGCGGTTTTAA 5' Ser337-Ala

Fig. 7

# INTERNATIONAL SEARCH REPORT

International Application No PCT/GB 88/00211

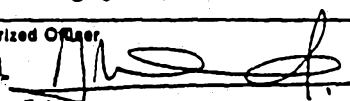
<b>I. CLASSIFICATION OF SUBJECT MATTER</b> (If several classification symbols apply, indicate all) <sup>6</sup>		
According to International Patent Classification (IPC) or to both National Classification and IPC		
IPC <sup>4</sup> : C 12 N 15/20; A 61 K 39/395		
<b>II. FIELDS SEARCHED</b>		
Minimum Documentation Searched <sup>7</sup>		
Classification System	Classification Symbols	
IPC <sup>4</sup>	C 12 N	
Documentation Searched other than Minimum Documentation to the extent that such Documents are included in the Fields Searched <sup>8</sup>		
<b>III. DOCUMENTS CONSIDERED TO BE RELEVANT <sup>9</sup></b>		
Category <sup>10</sup>	Citation of Document, <sup>11</sup> with indication, where appropriate, of the relevant passages <sup>12</sup>	Relevant to Claim No. <sup>13</sup>
A	Immunochemistry, volume 11, 1974, Pergamon Press (GB) R. Allan et al.: "Studies on the complement-binding site of rabbit immunoglobulin G-I. Modification of tryptophan residues and their role in anticomplementary activity of rabbit IgG", pages 175-180 --	
A	Chemical Abstracts, volume 93, no. 7, 18 August 1980, (Columbus, Ohio, US), F. Vivanco-Martinez et al.: "Chemical modification of carboxyl groups in human Fc <sub>γ</sub> fragment: structural role and effect on the complement fixation", see page 703, abstract 68353t, & Mol. Immunol. 1980, 17(3), 327-36 --	
A	Chemical Abstracts, volume 99, no. 11, 12 September 1983, (Columbus, Ohio, US), T. Hofstaetter et al.: "S-sulfonation: a reversible chemical modification of human immuno- ./.	
<p><sup>10</sup> Special categories of cited documents: <sup>10</sup></p> <p>"A" document defining the general state of the art which is not considered to be of particular relevance</p> <p>"E" earlier document but published on or after the international filing date</p> <p>"L" document which may throw doubts on priority claim(s) or which is cited to establish the publication date of another citation or other special reason (as specified)</p> <p>"O" document referring to an oral disclosure, use, exhibition or other means</p> <p>"P" document published prior to the international filing date but later than the priority date claimed</p> <p>"T" later document published after the international filing date or priority date and not in conflict with the application but cited to understand the principle or theory underlying the invention</p> <p>"X" document of particular relevance; the claimed invention cannot be considered novel or cannot be considered to involve an inventive step</p> <p>"Y" document of particular relevance; the claimed invention cannot be considered to involve an inventive step when the document is combined with one or more other such documents, such combination being obvious to a person skilled in the art.</p> <p>"A" document member of the same patent family</p>		
<b>IV. CERTIFICATION</b>		
Date of the Actual Completion of the International Search	Date of Mailing of this International Search Report	
13th July 1988	09 AUG 1988	
International Searching Authority	Signature of Authorized Officer	
EUROPEAN PATENT OFFICE	M. VAN MOL 	

III. DOCUMENTS CONSIDERED TO BE RELEVANT (CONTINUED FROM THE SECOND SHEET)		
Category *	Citation of Document, with indication, where appropriate, of the relevant passages	Relevant to Claim No
T	<p>globulins permitting intravenous application. II. Effect on Fc-mediated effector functions", see page 423, abstract 86345v, &amp; Vox Sang. 1983, 45(2), 155-65</p> <p>-----</p> <p>Nature, volume 332, 7 April 1988, A.R. Duncan et al.: "Localization of the binding site for the human high-affinity Fc receptor on IgG", pages 563-564</p> <p>-----</p>	