

M. MICKELSON.
 MAIL CARRIER.
 APPLICATION FILED JUNE 15, 1909.

934,980.

Patented Sept. 21, 1909.

2 SHEETS—SHEET 1.

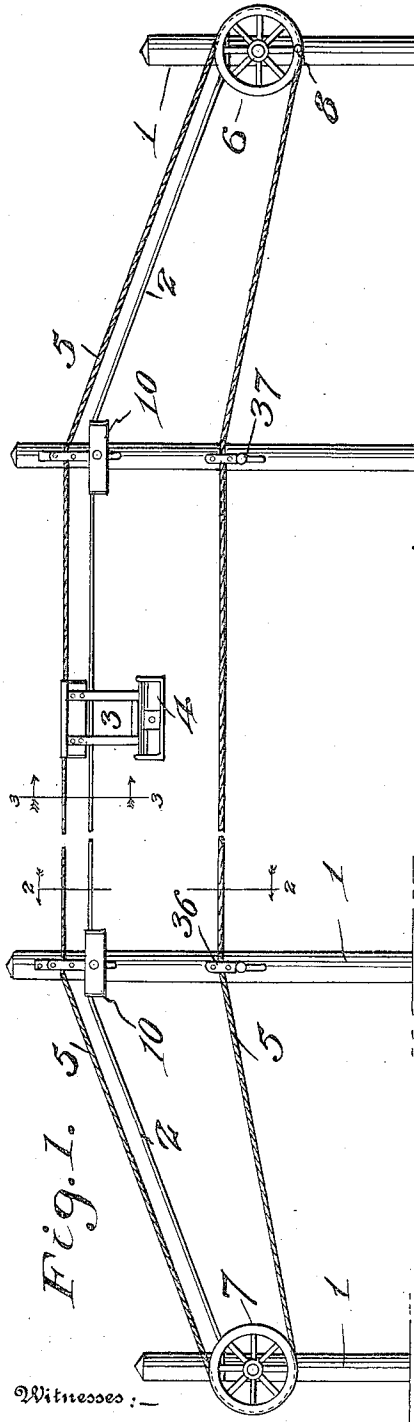

Fig. 1.

Witnesses:—

Jos. P. Wabbes.
 C. M. Ricketts

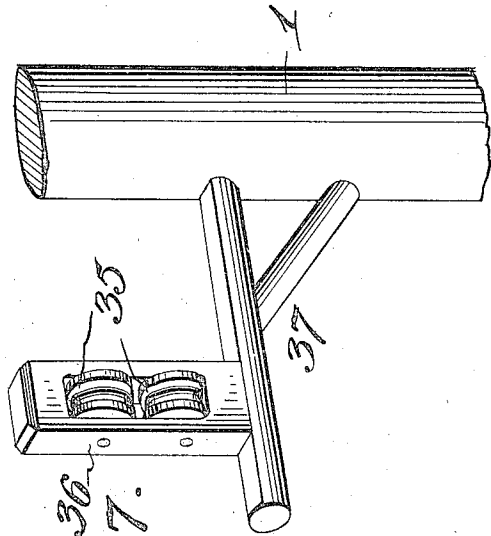

Fig. 7.

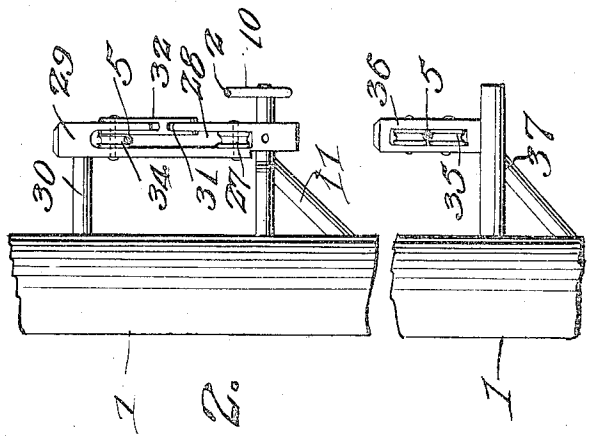

Fig. 2.

Inventor

Mikel Mickelson

384 Watson E. Coleman

Attorney

M. MICKELSON.
 MAIL CARRIER.
 APPLICATION FILED JUNE 16, 1909.

934,980.

Patented Sept. 21, 1909.

2 SHEETS—SHEET 2.

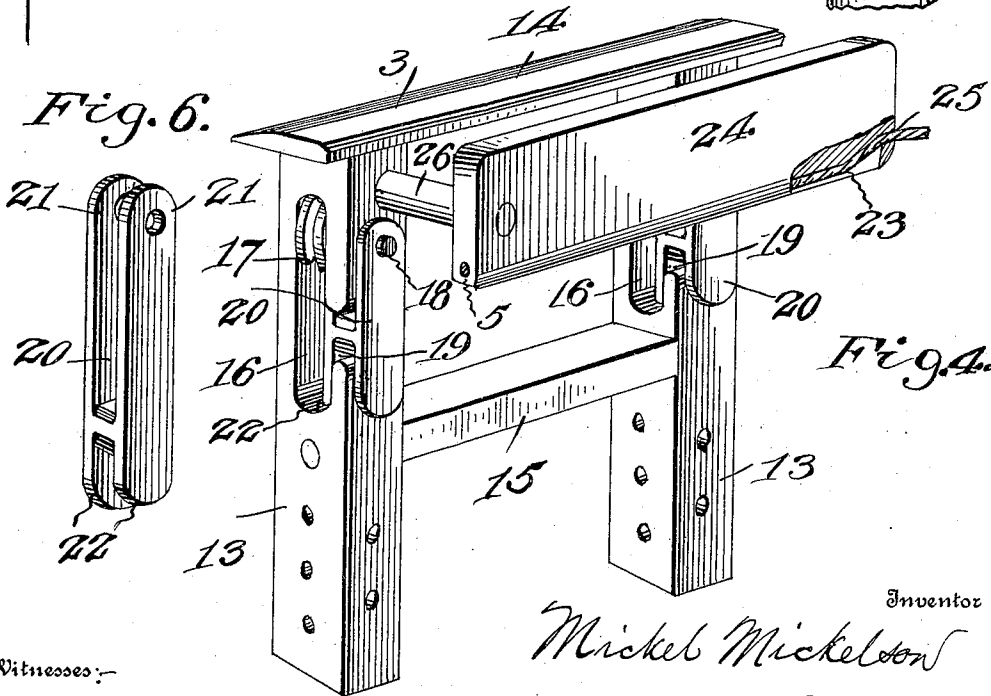
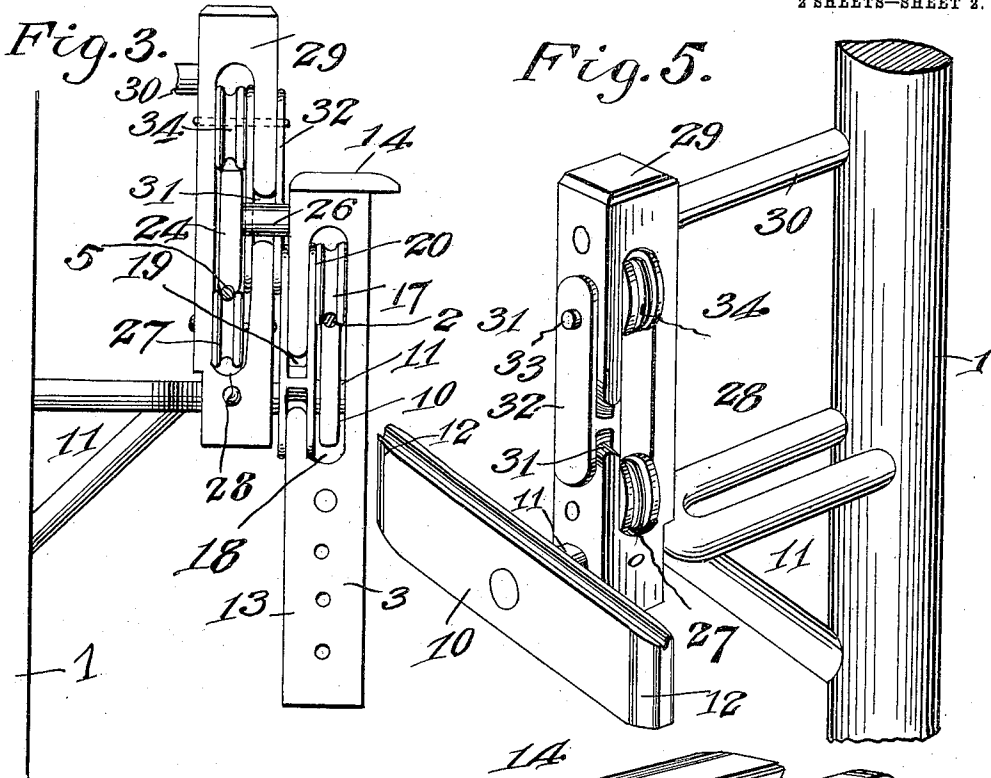

Witnesses:

Joe P. Walker
 E. M. Ricketts

Inventor

Mickel Mickelson

By: Walter Coleman

Attorney

UNITED STATES PATENT OFFICE.

MICKEL MICKELSON, OF SOLDIERS GROVE, WISCONSIN.

MAIL-CARRIER.

934,980.

Specification of Letters Patent. Patented Sept. 21, 1909.

Application filed June 15, 1909. Serial No. 502,334.

To all whom it may concern:

Be it known that I, MICKEL MICKELSON, a citizen of the United States, residing at Soldiers Grove, in the county of Crawford and State of Wisconsin, have invented certain new and useful Improvements in Mail-Carriers, of which the following is a specification, reference being had to the accompanying drawings.

This invention is an improved mail carrying device for carrying mail between a country residence and a road along which there is rural delivery service.

The object of the invention is to improve and simplify devices of this character and thereby render them more durable and less expensive in construction, more reliable in operation and capable of being used over hilly ground.

With the above and other objects in view, the invention consists of the novel features of construction and the combination and arrangement of parts hereinafter fully described and claimed, and illustrated in the accompanying drawings, in which—

Figure 1 is a view showing the improved mail carrying device on a reduced scale; Figs. 2 and 3 are vertical sectional views taken on the planes indicated by the lines 2—2 and 3—3 in Fig. 1; Fig. 4 is a perspective view of the carriage; Fig. 5 is a perspective view of one of the stationary guides; Fig. 6 is a similar view of one of the swinging guards; and Fig. 7 is a perspective view of one of the guides for the lower stretch of the traction cable.

In constructing my improved mail carrying device, I arrange a row of posts 1 between the house and road and on these posts is supported a track wire 2 for the carriage 3 of a mail box or receptacle 4 and also suitable guides for a traction cable 5 which is endless and has the carriage 3 connected to it, its end portions being passed over grooved pulleys 6, 7 arranged at the house and road ends of the line and journaled on the posts 1 or on other suitable supports. The pulley 6 at the house end of the line serves as a driving pulley and may be provided with a hand crank 8 or other suitable means which will enable it to be rotated to move the carriage 3 in either direction over the track 2. The track 2 is preferably made of wire such as used for telephone lines and its ends are suitably anchored to the endmost posts. At points intermediate its ends it is supported

from the posts 1 by securing it in the grooved upper edges 9 of vertically disposed plates 10 fixed to brackets 11 projecting from the intermediate posts. The ends of the plates 10 are tapered to an edge, as shown at 12, so that the carriage 3 will not be caught upon them.

The carriage 3 comprises two uprights 13 united by a longitudinal top piece 14 and an intermediate longitudinal bar 15.

The mail box or receptacle 4 is suitably connected to the depending lower ends of the uprights 13. It will be understood that the mail box or receptacle may be of desired form and construction. In the upper portions of the uprights 13 are formed vertical openings 16 of sufficient size to receive the track wire 2 and its supporting plates 10, grooved pulleys 17 being journaled on transverse pins 18 in the upper portions of the openings 16, whereby the carriage will run freely on the track. To permit the carriage to be applied to and removed from the track the openings or slots 16 open upon one side of the uprights 13 through transverse slots or openings 19. Said slots 19 are adapted to be normally closed by swinging guard members 20 each of which has upper and lower bifurcated portions to provide upper and lower plates 21, 22 which straddle the spaced portions of one side of the upright 13 which portions are formed by the transverse slots 19. The spaced upper plates 21 are hung from the pivots 18 so that the guards or closures for the slots or openings 19 swing freely and drop by gravity to operative position to close said slots or openings 19. It will be seen on reference to the drawings that the openings 19 are so disposed and of such size as to permit the brackets 11 to pass through them as the carriage passes said brackets and that the guards or closures 20 will be swung upwardly by said brackets as the carriage passes the latter.

The traction cable 5 may be a wire, a rope or any other flexible element and it is attached to the upper portion of the carriage by passing it through a longitudinal groove 23 formed in the bottom edge of a plate 24 and also through angularly arranged openings 25 formed in the ends of said plate, the latter being disposed vertically and secured to and spaced from one side of the upper portion of the carriage by means of horizontal studs 26. The upper

stretch or run of the cable 5 is supported and guided by grooved pulleys 27 journaled in the lower portions of slots 28 formed in stationary uprights 29 secured to the intermediate posts 1 by the brackets 11 and additional brackets 30. Said stationary uprights 29 have their upper ends fixed to the bracket 30 and their lower ends are forked or bifurcated to straddle the brackets 11 to which latter they may also be bolted or otherwise secured. To permit the cable attaching plate 24 on the carriage to pass the uprights 29 the latter are formed on one side with transverse slots or openings 31 which communicate with the slots or openings 28 and which are adapted to receive the spacing studs or pins 26. The transverse slots 31 are adapted to be closed by swinging guards or closures 32 which are similar to the guards 20 and which swing from the pivots 33 of grooved rollers 34 arranged in the upper portions of the slots or openings 28 in the stationary uprights 29 and adapted to prevent the cable 5 and also the plate 24 from binding against the upper walls of said slots 28.

The lower stretch or run of the cable 5 is supported and guided between pairs of upper and lower grooved pulleys or rollers 35 journaled in slotted uprights 36 mounted on brackets 37 projecting from the posts 1.

From the foregoing it is thought that the construction, operation and advantages of the invention will be readily understood without a more extended explanation. It may be noted, however, that all parts of the device are preferably constructed of metal or other material which will withstand the weather and be strong and durable. The peculiar construction of the several parts renders the device exceedingly reliable in operation since the parts will not catch or bind and will be light and easy running.

While I have shown and described in detail the preferred embodiment of my invention, it will be understood that I do not wish to be limited to the precise construction set forth since various changes in the form, proportion and arrangements of parts and in the details of construction may be resorted to within the spirit and scope of the invention.

Having thus described the invention what is claimed is:

1. A device of the character described comprising a track, laterally extending supports for the same, a carriage to travel on the track and having intersecting vertical and horizontal openings, the vertical opening being adapted to receive the track and the horizontal opening said supports, a guard for said horizontal opening, a traction cable for moving said carriage over the track, a cable connecting member, supports for spacing said connecting member from

the carriage, stationary guides for the cable and provided with vertical and horizontal intersecting slots, the vertical slots being adapted to receive the cable and the cable connecting member and the horizontal slots being adapted to receive the spacing supports for said cable connecting member and guards for said vertical slots of the cable guides.

2. A device of the character described comprising a track, laterally extending supports for the same, a carriage to travel on the track and having intersecting vertical and horizontal openings, the vertical opening being adapted to receive the track and the horizontal opening said supports, a traction cable for moving said carriage over the track, a cable connecting member, supports for spacing said connecting member from the carriage, and stationary guides for the cable and provided with vertical and horizontal intersecting slots, the vertical slots being adapted to receive the cable and the cable connecting member and the horizontal slots being adapted to receive the spacing supports for said cable connecting member.

3. In a device of the character described, the combination of a track, a carriage to travel thereon, a traction cable, a horizontal cable-connecting plate attached to said cable, horizontal spacing and supporting studs spacing said connecting member from the carriage, stationary guides for the cable and having intersecting vertical and horizontal slots, the vertical slots being adapted to receive the cable and said connecting plate and the horizontal slots to receive the spacing and supporting studs and swinging guards for said horizontal slots.

4. In a device of the character described, the combination of a series of posts, brackets thereon, plates upon said brackets, a track wire having its ends anchored and its intermediate portions supported on said plates, an endless traction cable, grooved guiding and driving wheels for said cable, means for rotating said driving wheel, supporting and guiding devices for the lower stretch of the cable, stationary guides for the upper stretch of the cable, the last mentioned guides having intersecting vertical and horizontal slots, guards for the horizontal slots, a carriage to travel on the track and having upright portions with intersecting vertical and horizontal slots, guards for said horizontal slots on the upright portions of the carriage, a cable connecting member fixed to the cable and supports spacing said connecting member from the carriage.

In testimony whereof I hereunto affix my signature in the presence of two witnesses.

MICKEL MICKELSON.

Witnesses:

JOHN BRAKKE,
N. O. PETERSON.