

June 19, 1923.

1,459,568

J. K. BLUM

HAMMER ADJUSTMENT

Filed Aug. 29, 1921

2 Sheets-Sheet 1

Fig. 1.

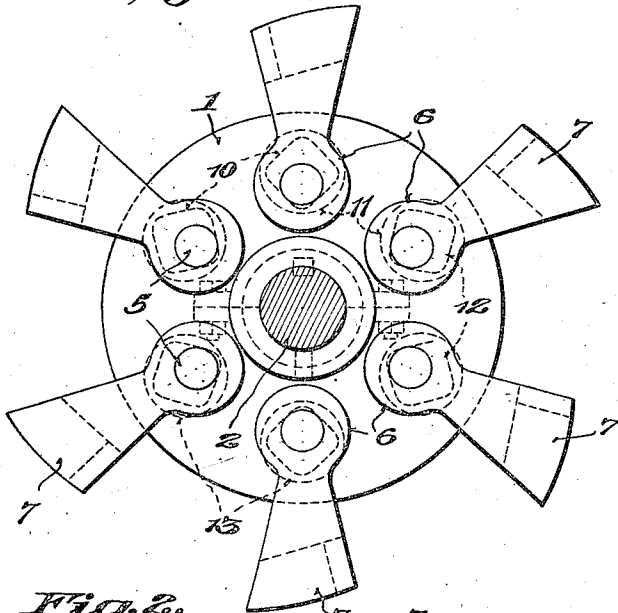

Fig. 3.

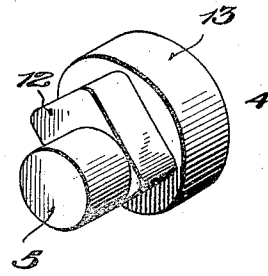

Fig. 2.

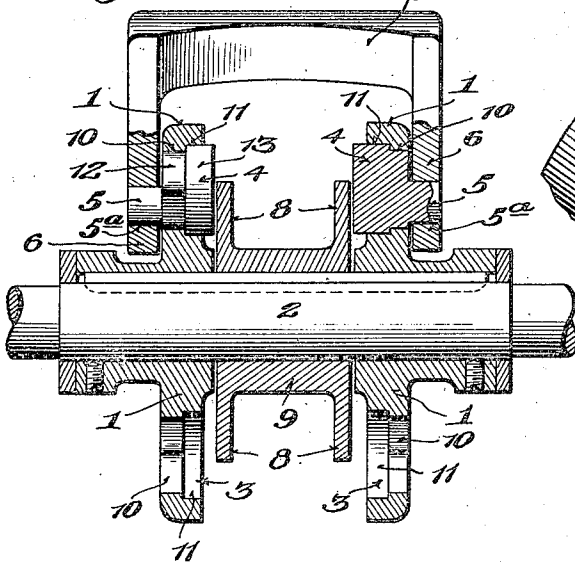
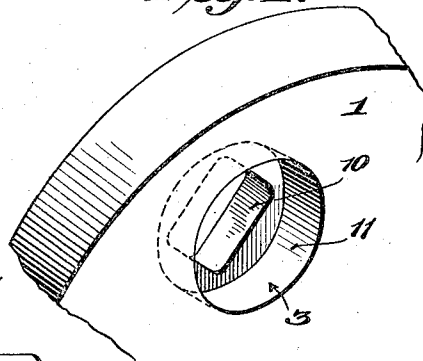

Fig. 4.



Inventor

Joseph K. Blum,

WITNESSES:-

*Chas. R. Grigsby*  
*Conroy Buff*

By

*W. M. ...*

Attorney

June 19, 1923.

1,459,568

J. K. BLUM

HAMMER ADJUSTMENT

Filed Aug. 29, 1921

2 Sheets-Sheet 2

Fig. 5.

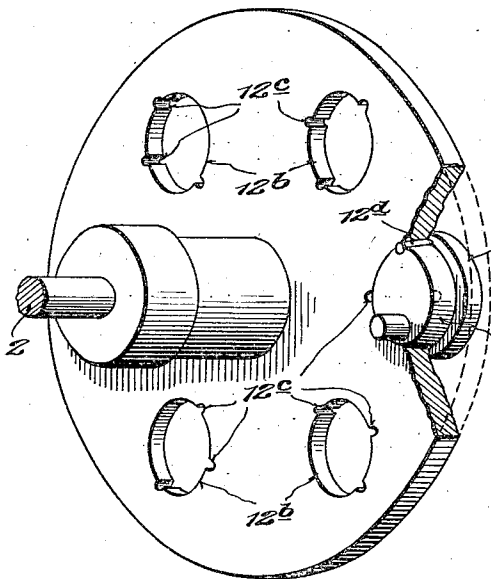

Fig. 7.

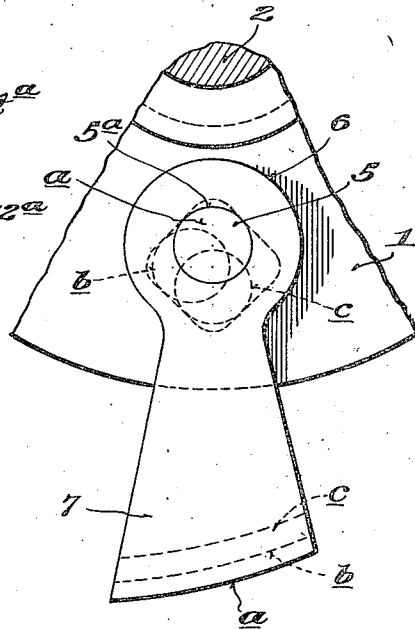
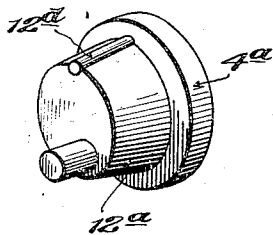

Fig. 6.



WITNESSES:-

Chas. L. Griesbauer  
Emory D. Gruff

Inventor

Joseph K. Blum,

By *J. M. Blum*

Attorney

# UNITED STATES PATENT OFFICE.

JOSEPH KLEE BLUM, OF GREENBURGH, NEW YORK, ASSIGNOR TO K-B PULVERIZER COMPANY, INC., OF NEW YORK, N. Y., A CORPORATION OF NEW YORK.

## HAMMER ADJUSTMENT.

Application filed August 29, 1921. Serial No. 496,778.

*To all whom it may concern:*

Be it known that I, JOSEPH K. BLUM, a citizen of the United States, residing at Greenburgh, in the county of Westchester and State of New York, have invented certain new and useful Improvements in Hammer Adjustments, of which the following is a specification.

This invention relates to an improved assembly and adjustment for hammers or beaters of the type used in crushers or disintegrators, permitting the hammer wear to be compensated for in a practical and reliable manner.

One of the objects of the invention is to provide a simplified construction having a minimum number of parts which also admit of the adjustment of the hammers with a minimum expenditure of time and labor. In that connection the invention also contemplates the provision of a heavier and more substantial construction which permits of better distribution and arrangement of the parts subjected to the greatest wear; thereby materially increasing the life and insuring proper functioning of the various parts under the most rigorous operating conditions.

A further object of the invention is to provide a construction which, by reason of its relatively few parts, permits of facile taking apart and reassembling to effect the desired adjustments.

With the above and other objects in view which will more readily appear as the nature of the invention is better understood, the same consists in the novel construction, combination and arrangement of parts, hereinafter more fully described, illustrated and claimed.

A preferred and practical embodiment of the invention is shown in the accompanying drawings, in which:

Figure 1 is a side elevation of a disintegrating rotor embodying improved hammer adjustment.

Figure 2 is a vertical sectional view thereof.

Figure 3 is a detail perspective view of one of the adjustable journal pins:

Figure 4 is a detail perspective view of a portion of one of the journal discs more clearly showing the arrangement for mounting the adjustable journal pins therein.

Figure 5 is a detail perspective view of a modified form of disc.

Figure 6 is a detail perspective view of a modified form of journal pin for use in connection with the disc shown in Figure 5.

Figure 7 is a diagram illustrating the adjustment.

Similar reference characters designate corresponding parts throughout the several figures of the drawings.

In the operation of disintegrating apparatus of the hammer mill type, it is a well known fact that the hammers are subjected to considerable wear on their crushing or grinding edge, and, after a period of use, frequently become worn to such an extent that the radial distance of the crushing edge from the axis of the rotor is considerably shortened. Accordingly, an object of the present invention, as previously indicated, is to provide novel means for adjusting the relative position of the hammer in such a manner that its crushing edge will be projected outwardly to such an extent that its full efficiency will be restored. My former Patent No. 1,185,619, dated June 6, 1916 shows a practical and reliable construction for compensating for such wear, and the present invention is intended to be an improvement upon the construction shown in that patent.

Therefore, to that end, the present construction embodies in its organization a novel and simplified assembly of parts which primarily consists of a pair of journal plates or discs 1—1 suitably keyed on the rotor or disintegrator shaft 2 and having at spaced intervals a plurality of adjustment openings designated generally as 3, and hereinafter more fully described in detail, for accommodating a novel type of adjustable journal pins 4. The said journal pins 4 are provided with eccentric bearing studs 5 for engaging the bearing eyes 5<sup>a</sup> at the end of the arms 6 of the hammers 7, and may be locked or held in position in the discs by the locking flanges 8 of a split spacing collar 9, which, in addition to locking the adjustable journal pins in place maintains the journal discs in proper spaced relation.

In connection with the construction above described it is pointed out that one of the distinctive features of the present invention resides in providing the unitary jour-

nal discs 1—1 for receiving the adjustable journal plates or pins 4, in such a manner that they may be directly locked in position in the discs by means of the split spacing collar 9. This eliminates extra parts which might otherwise be employed and materially contributes to the simplicity of making the adjustment of the hammers when required. That is to say, it will be observed that when it is desired to shift the adjustable journal pins to accomplish the desired adjustment, it is only necessary to remove the split collar 9 whereupon the adjustable journal pins are immediately released for adjustment without the necessity of manipulating any other part of the construction.

The foregoing description emphasizes the improved general assembly for the entire construction, but other novel and distinctive features reside in the adjustable journal plates or pins 4 and the means for mounting the same in the journal discs to prevent undue play, thereby materially adding to the stability of the entire assembly. In that connection it may be observed that the adjustment openings 3 in the discs 1—1 may consist of the square or equivalent non-circular shaped locking portion 10 opening at the outer face of the disc, and a communicating circular portion forming a seat or socket 11 opening through the inner face of the disc. The square portion 10 referred to is adapted to receive the square locking body portion 12 of the adjustable journal pin 4, while the round head portion 13 of the latter fits tightly in the socket 11, thereby preventing relative movement or "play" between the pin 4 and the disc while the non-circular body portion 12 prevents relative rotary movement of the pin in the opening.

As will be observed from Figure 3 the eccentric bearing stud 5 of the journal pin is located at one end of the square locking portion 12, and as will be observed from Figures 1 and 7, the diagonals of the square portion of the openings 3 are coincident with the radii of the disc at equi-distant points throughout its circumference. Thus, when the parts are originally assembled the bearing stud 5 may be supported relatively close to the axis of the shaft 2 of the rotor as shown at *a* in Fig. 7, or in other words, the length of the radius of the point of pivotal support for the hammer 7 with reference to the axis of the rotor will be the shortest, and, as the hammer wears, the bearing stud 5 may be shifted 90°, or 180° to the positions marked *b* and *c* which will have the effect of lengthening the hammer and bringing it closer to the bottom of the disintegrator.

Figures 5 and 6 show a modification of the construction herein shown wherein the relative adjustment of the hammers may be effected by a different form of non-circular

part on the adjustable journal pin. That is to say, instead of a square body portion the pin 4<sup>a</sup> may be provided with a round body 12<sup>a</sup> adapted to fit in a circular opening 12<sup>b</sup> in the disc, the said body 12<sup>a</sup> and edges of the opening 12<sup>b</sup> being provided with complementary notches 12<sup>c</sup> which may register to receive a locking pin or pins 12<sup>d</sup>. By increasing the number of notches in the circumference of the round portion 12<sup>a</sup> and correspondingly increasing the notches in the edges of the opening 12<sup>b</sup>, it will be apparent that relatively minute adjustments may be readily effected to obtain various degrees of fineness of the crushed product.

From the foregoing it will be apparent that one of the distinctive features of the present improvement is a novel rotor construction which is capable of being readily taken apart and likewise reassembled for effecting the adjustment of the hammers which are mounted on the eccentric bearing studs 5 of the adjustable journal pins 4. Also, in connection with the pins a distinctive feature is the eccentric stud and the non-circular part for interlocking with the disc to prevent accidental relative rotary movement of the pin in the disc which would change the operating radius of the hammer. However, on the other hand when it is desired to effect the adjustment of the hammer, the pin may be readily released and turned to thereby move the same radially outward.

It will also be noted that the split spacing collar provides simple and practical means for releasably locking the pins in the discs, and insures the proper seating of the enlarged head portions 13 thereof in the sockets of the discs which prevents looseness or undesirable "play" that would otherwise effect the proper functioning of the hammer.

Without further description it is thought that the many features and advantages of the present invention will be readily apparent, and it will of course be understood that changes in the form, proportion, and minor details of construction may be resorted to, without departing from the spirit of the invention or scope of the appended claims.

I claim:

1. A hammer assembly for disintegrating rotors including a shaft, a plate on said shaft, a journal pin adjustably mounted in said plate and provided at one side with an integral bearing stud projecting therefrom, a hammer mounted on said stud, and locking means for holding said journal pin set in its adjusted positions.

2. A hammer assembly for pulverizing machines including a shaft, journal plates on said shaft, adjustable journal pins mounted in said plates and provided with eccentric

bearing studs rigid therewith, hammers mounted on said studs, and locking means for holding the journal pins set in their adjusted positions.

5 3. A disintegrating rotor including a shaft, journal discs on said shaft, adjustable journal pins mounted in said discs and having eccentric bearing studs projecting at the outer faces of the discs, hammers mounted on said bearing studs, and means arranged at the inner side of the disc for engaging the inner ends of the adjustable pins for locking the same in the disc.

15 4. A disintegrating rotor including a shaft, journal discs on said shaft, adjustable journal pins mounted in said discs and having eccentric bearing studs projecting at the outer faces of the discs, hammers mounted on said bearing studs, a split collar having flanges at opposite sides thereof and engaging with the inner ends of the adjustable journal pins for locking them in the disc.

25 5. In a disintegrating rotor, a hammer adjustment including in combination with the hammer, a journal disc having an angular opening, an adjustable journal pin having an angular body portion, an eccentric bearing stud carried by said angular portion and adapted to be inserted in said opening whereby the bearing stud projects beyond the plane of one face of the disc thereby to constitute a bearing for the hammer, and means at the other side of the disc for holding the adjustable journal pin therein.

40 6. In a disintegrating rotor, a hammer adjustment including in combination with the hammer, a journal disc having an opening whose side walls are of different diameters, an adjustable journal pin having an eccentric bearing stud for engaging with the hammer and the body portion of said pin being of relatively shouldered formation to correspond with the different diameters of the opening in the disc, and means for holding the pin in the opening of the disc.

7. A disintegrating rotor, a hammer adjustment including in combination with the hammer, a journal disc having an opening whose sides are of stepped formation, an adjustable journal pin having a body also of stepped formation for engaging with the opening, and a relatively eccentric bearing stud carried by the pin and projecting to the outer face thereof to engage with the hammer, and means for holding the pin in the disc.

8. In a disintegrating rotor, a hammer adjustment including in combination with the hammer, a journal disc having an opening of different diameters, an adjustable journal pin having an eccentric bearing stud for engaging with the hammer and also having a body consisting of portions of different diameter for engaging in said openings, means whereby the side wall portion of one diameter of the opening cooperates with a corresponding diameter on the body of the pin to prevent relative rotary movement between the pin and the disc, and means for holding the pin in the disc.

9. In a disintegrating rotor, a hammer adjustment including in combination with the hammer, a journal disc including an opening forming a socket portion at the inner side of the disc and a relatively angular portion opening at the outer face of the disc, an adjustable journal pin having a circular head portion for fitting in the socket of the opening and a relatively angular portion for fitting in the angular portion of said opening, a bearing stud carried by the relatively angular portion of the pin and projecting beyond the outer face of the disc to engage the hammer, and means at the inner side of the disc for maintaining the pin in the opening.

In testimony whereof I hereunto affix my signature in the presence of two witnesses.

JOSEPH KLEE BLUM.

Witnesses:

HILDA MOSES,  
D. L. BRAINE.