

(21) Application No 9209649.4

(22) Date of filing 05.05.1992

(71) Applicant  
Catherine Walsh  
71 Bradford Street, Eastbourne, East Sussex,  
BN21 1JA, United Kingdom

(72) Inventor  
Catherine Walsh

(74) Agent and/or Address for Service  
S J Avery & Co  
Sardinia House, 52 Lincoln's Inn Fields, London,  
WC2A 3LZ, United Kingdom

(51) INT CL<sup>5</sup>  
A47K 10/48 3/22 4/00

(52) UK CL (Edition L)  
A4V V29F  
A4N N2B

(56) Documents cited  
GB 2243546 A GB 2222944 A GB 2146522 A  
US 3878621 A

(58) Field of search  
UK CL (Edition L) A4V  
INT CL<sup>5</sup> A47K 10/48

(54) Shower and dryer unit

(57) A combined shower and dryer for washing and drying a human or animal body in a single enclosure (1), is provided with movable nozzles (3). The nozzles spray water at sides of the user's body, and are moved up and down to reach all parts of the body. Then jets of temperature controlled air are directed at the user's body, from the same movable nozzles to dry the user's body.

Fig 2

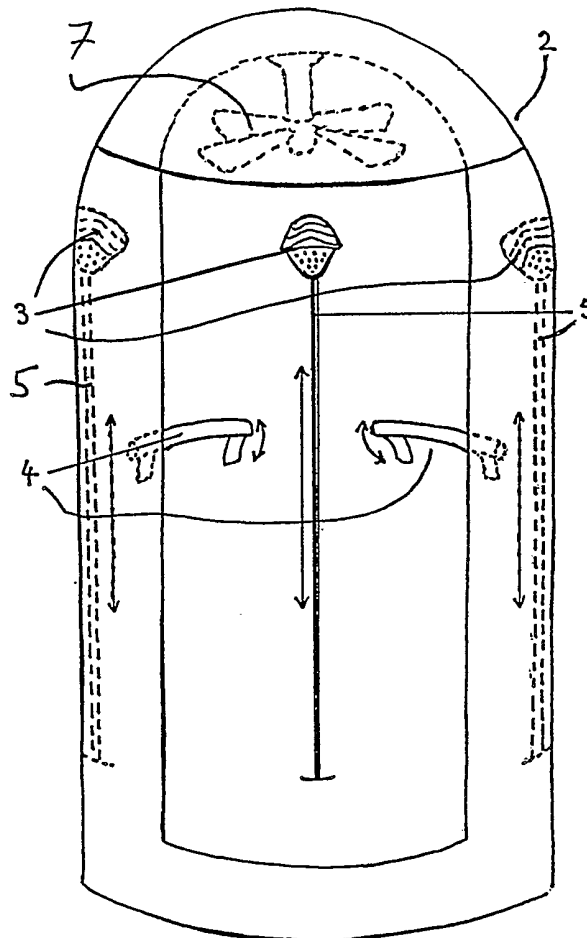

Fig 1

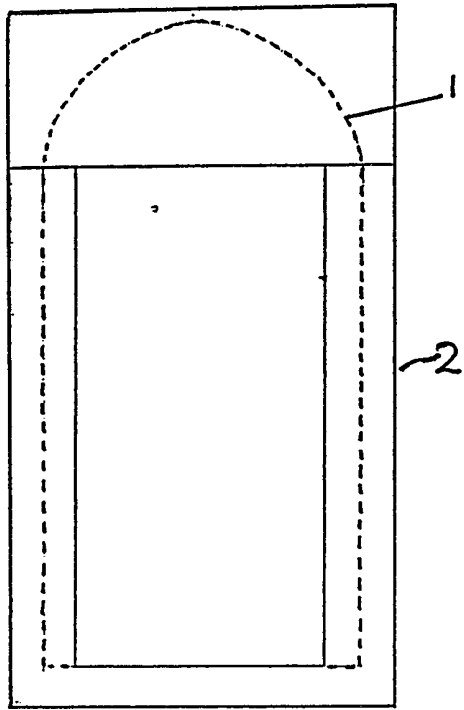

Fig 2

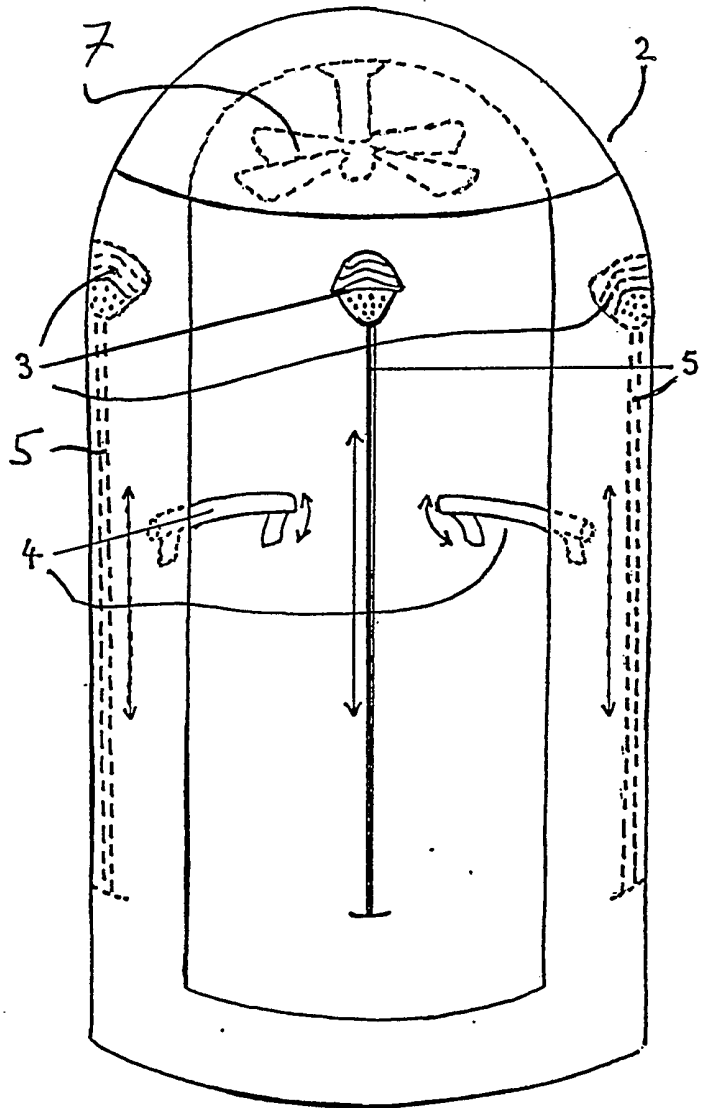

Fig 3

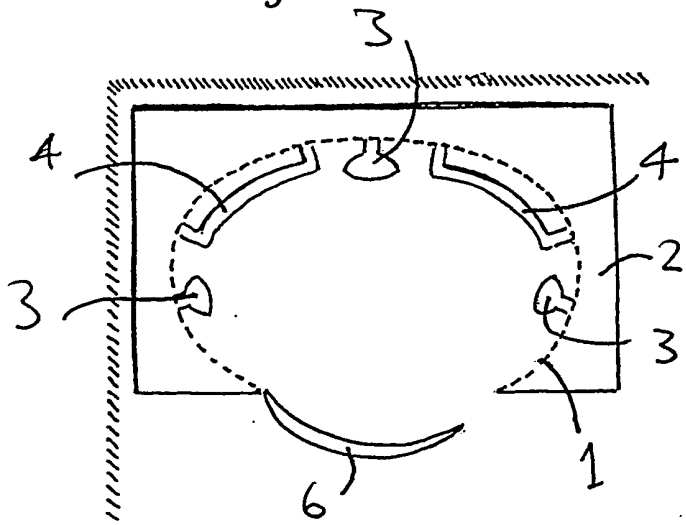
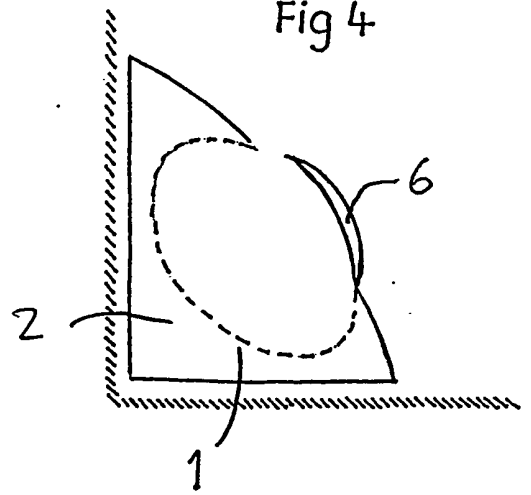

Fig 4



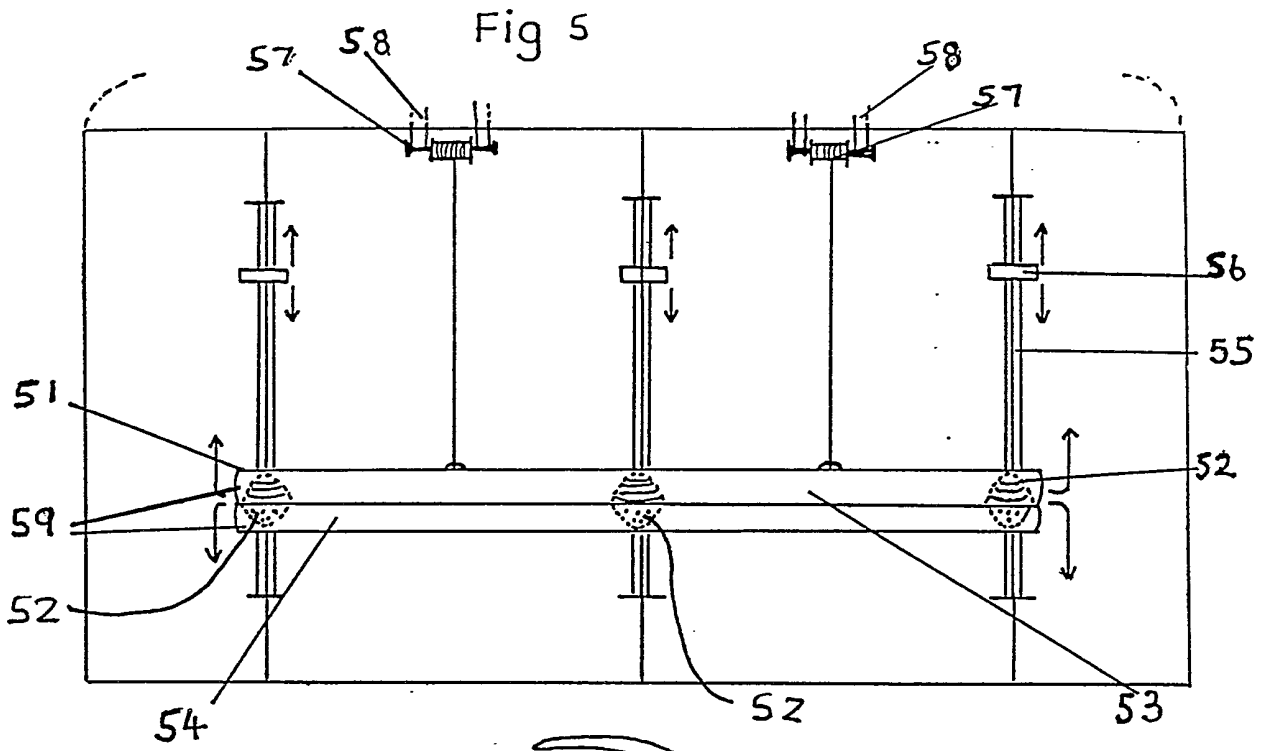

Fig 6

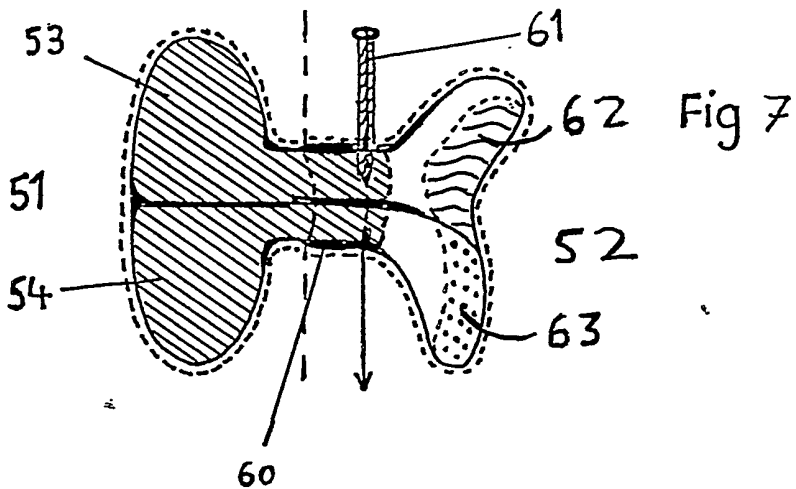
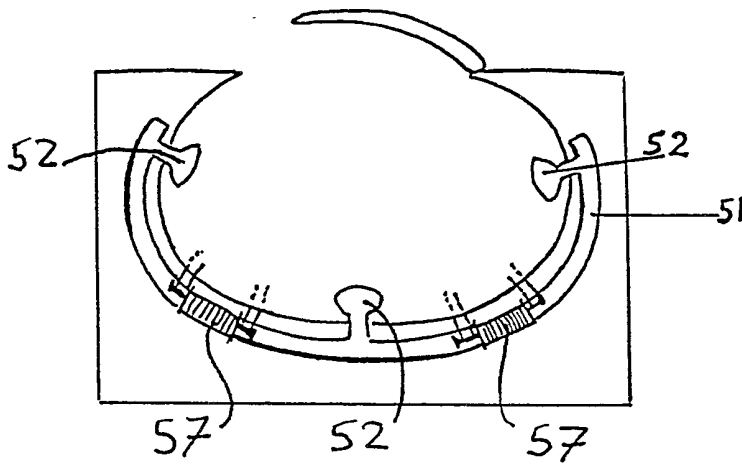

Fig 8

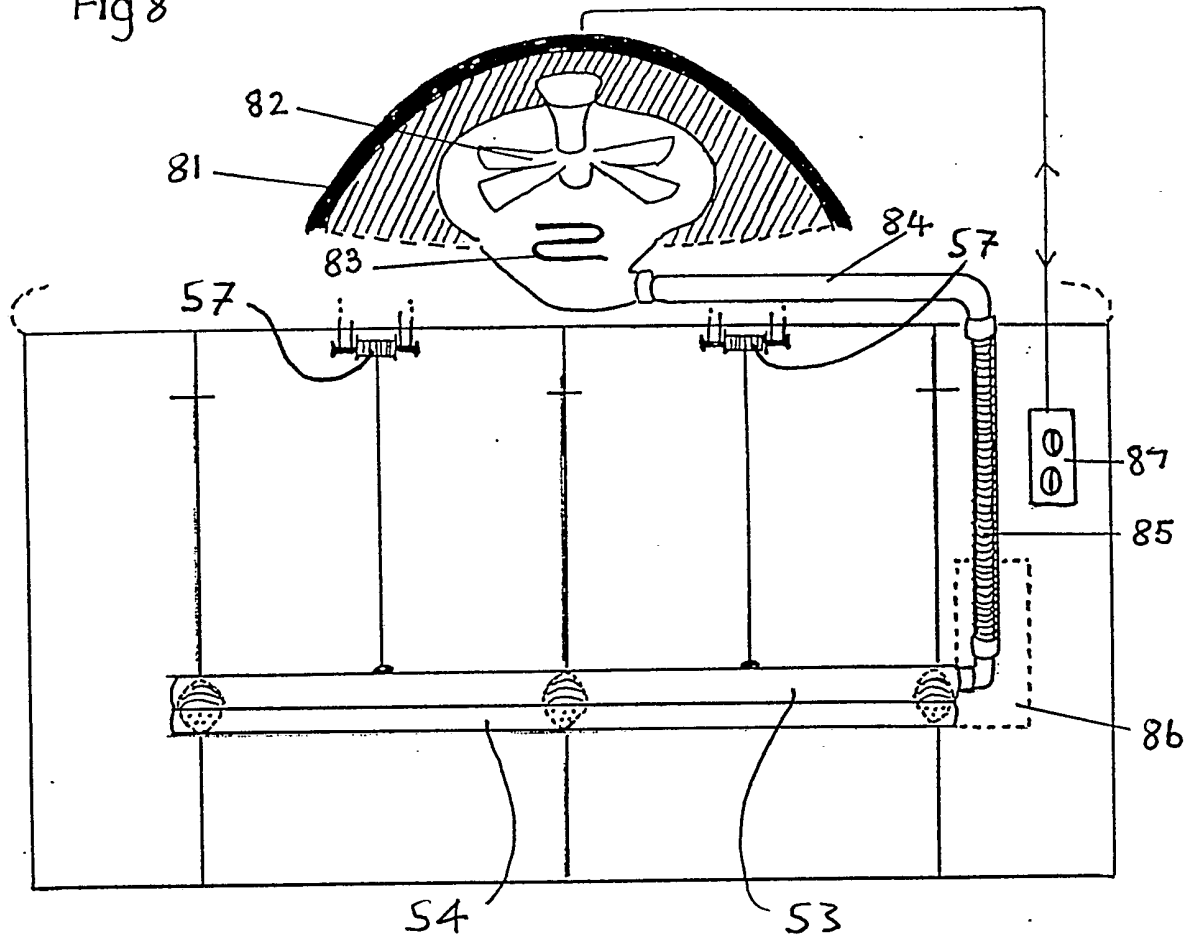
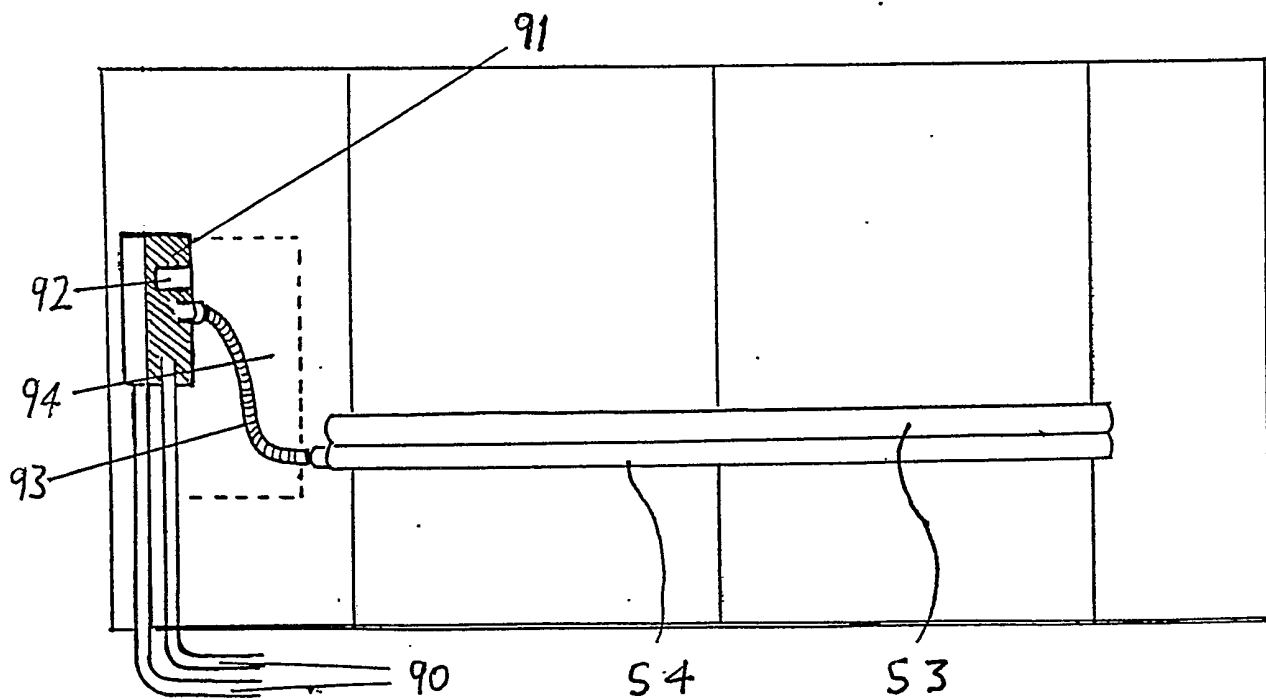

Fig 9



5

SHOWER AND DRYER UNIT

The invention relates to washer/dryers, showers, methods of washing and methods of drying, all for human and animal bodies.

The everyday process of personal washing and drying is normally carried out using a bath or shower followed by rubbing with a towel over the body. There are a number of drawbacks with this two stage process. Firstly, there can be considerable discomfort to the person due to rapid temperature changes. Although the warm water of the bath or shower is usually easily controllable to a comfortable level, immediately the shower is stopped or the person leaves the bath, evaporation rapidly causes cooling of the skin. If the air temperature in the bathroom is sufficiently warm to compensate for this cooling, then it will probably be uncomfortably warm at all other times.

To a some extent, the cooling effect can be overcome by vigorous rubbing with a towel, which reduces evaporative cooling since water is rapidly removed from the skin. Moreover warming is achieved by the friction of the towel rubbing on the skin. Further warming is caused by the warmth generated by the physical exertion of the rubbing.

35

Another partial solution is to house the bath or the shower cubicle in a very small space. The small amount of air is warmed to a comfortable temperature by the hot water from the shower or the bath.  
5 However, when the bather has finished the bath or shower, drying within the small space with a towel is difficult.

Drying by towel also has the disadvantage of being  
10 less hygienic since the towel can transmit germs. This is obviously a significant consideration to organisations such as hospitals, old peoples homes, health clubs and hotels for example. Also, the time and expense involved in collecting, washing and  
15 replacing towels involves considerable expense and waste of energy.

Another major drawback of drying by towel is the physical effort involved. It can be exhausting for  
20 the person or for others trying to help. Nursing assistance in bathing and drying elderly and physically handicapped people, or very young children, can also be expensive to provide and embarrassing for the person being washed. The  
25 problem of rapid cooling by evaporation during drying can be uncomfortable and lead to shivering. All of this may discourage elderly people or small children from washing.

30 There is also a safety problem with drying by towel. Bath and shower areas are surrounded by hard surfaces, and the floors are often slippery if damp. The physical movement necessary when drying by towel means there is an increased danger of a slip or a  
35 knock which could cause injury.

It is known that some parts of the body can be dried by hot air, such as the hands, face or hair. However, the heat loss from such relatively small parts of the body is not usually sufficient to cause significant discomfort, and hot air is used in place of towels for the purposes of speed of drying in the case of hair, and for the purpose of improved hygiene in the case of hands and face. Some physical effort is still required in the case of hand or hair dryers, since hands need to be rubbed together, and in the case of a hand-held hair dryer, it must be held up and directed towards the head from a number of different angles. Such dryers are clearly unsuitable for drying the whole body.

Accordingly, there remains the problem of washing and drying a person with minimum physical effort on the part of the person, while maintaining the person at a constant comfortable temperature despite the cooling by evaporation.

A further problem arises with conventional shower units in that if a single nozzle is used, then physical effort is required either to move the nozzle, or the body, to bring different parts of the body into the line of the spray. If multiple nozzles are provided, either water consumption is increased, or water pressure is shared between the nozzles resulting in reduced effectiveness of the washing action from any one nozzle.

According to a first aspect of the present invention, there is provided a dryer for a human or animal body, comprising a plurality of gas directing means, for directing a drying gas at various parts of the body simultaneously.

According to a second aspect of the present invention, there is provided a dryer for a human or animal body comprising a gas directing means and drive means for moving the gas directing means to  
5 direct a drying gas at various parts of the body.

According to a third aspect of the present invention, there is provided a dryer for a human or animal body comprising an enclosure substantially corresponding  
10 to the dimensions of the body to be dried leaving sufficient separation between body and enclosure for gas flow, and means for directing a drying gas through the enclosure.

15 According to a fourth aspect of the present invention, there is provided a washer dryer for a human or animal body comprising:

an enclosure;  
a shower assembly for washing the body in the  
20 enclosure; and

a dryer comprising means for directing a drying gas through the enclosure.

According to a fifth aspect of the invention there is  
25 provided a shower unit having a nozzle for directing water at a user, and a drive means for moving the nozzle relative to the user to direct water at various parts of the user.

30 According to a sixth aspect of the invention there is provided a method of drying a human or animal body comprising the step of directing a drying gas at various parts of the body simultaneously using a plurality of gas directing means.

35



According to an seventh aspect of the present invention there is provided a method of drying a human or animal body comprising the steps of using a gas directing means to direct a drying gas at the body, and moving the gas directing means to direct the gas at various parts of the body using a drive means.

According to a eighth aspect of the present invention there is provided a method of drying a human or animal body comprising the step of:

directing a drying gas through an enclosure surrounding the body, the dimensions of the enclosure corresponding substantially to the dimensions of the body to leave sufficient separation for gas flow between the body and the enclosure.

According to a ninth aspect of the present invention there is provided a method of washing a human or animal body comprising the steps of:

spraying water through a nozzle at one part of the body;

moving the nozzle using a drive means so as to direct water at different parts of the body.

For a better understanding of the invention and how the same may be carried into effect, embodiments will now be described by way of example with reference to the following drawings, in which:

Figure 1 shows a cross section of the shell of a first embodiment;

Figure 2 shows a side view looking into the embodiment;

35

Figures 3 and 4 show plan views of alternative configurations;

Figure 5 shows a side view from inside the embodiment showing three vertical tracks;

5 Figure 6 shows a plan view of the embodiment;

Figure 7 shows a cross section of a carriage bar and nozzle;

Figure 8 shows a schematic diagram of the drying air supply for the embodiment; and

10 Figure 9 shows a schematic diagram of the hot and cold water supply for the embodiment.

Reference will now be made to the Figures in more detail. The Figures illustrate a personal  
15 washer/dryer unit for performing washing and drying operations on an individual in an automatic or semi-automatic manner.

In order to use the unit, a person is accommodated  
20 within an internal chamber inside an enclosure 1 which is accommodated within an outer housing 2. The user will gain access to the chamber through a door 6, as shown best in Figure 3.

25 Once properly accommodated within the chamber, either in a standing or seated position, the user is initially washed by a jetting action produced by water emerging from a set of nozzles 3. Following the washing operation, the user will be dried by air  
30 flow emerging also from suitable air outlets on the nozzles 3.

More details of the construction and operation of the unit will now be given with further reference to the  
35 Figures.

As can be seen from Figure 3, the enclosure 1 has an elliptical plan view cross-section which corresponds substantially to the shape of the human body.

5 The enclosure 1 may be contained within the square housing 2 as shown in Figures 1 and 3 or a broadly triangular housing as shown in Figure 4.

10 Figure 2 shows three nozzles 3 which spray water to wash the person from three different sides simultaneously. The nozzles are operable to move up and down automatically while spraying water. Tracks 5 are provided to guide the nozzles 3.

15 To dry the person, a fan 7 is provided above the enclosure to force a drying gas, usually air, through the movable nozzles 3. During drying, the nozzles are moved up and down the tracks in order to direct air towards various parts of the person's body.

20 The dual purpose nozzles 3 are shown in more detail in Figure 7 as described later. Hinged handrails 4 provide an optional safety feature as shown in Figures 2 and 3 to assist frail or elderly people,  
25 and reduce the need for assistance from carers or nurses.

A door 6 is provided to allow entry into the enclosure. The door is hinged, and may be shaped to  
30 conform to the broadly elliptical plan view of the enclosure 1.

In operation, the user steps into the enclosure 1, closes the door 6 and starts the shower operation.  
35 The nozzles 3 move up and down the tracks 5 spraying

water at substantially all parts of the person. The person need hardly move. Soap may be introduced into the water flow to improve the cleaning action, or the person may apply soap themselves manually.

5

Once washed and rinsed, the drying operation starts. Again the nozzles 3 move up and down along the tracks, but air instead of water is forced through the nozzles at various parts of the person. There is again little need for the person to move during drying.

10

Figure 4 shows a plan view of an alternative configuration in which the housing is placed in a corner to save space.

15

Figure 5 shows in schematic form the interior of the washer/dryer unit.

20

To feed the air from the fan to the nozzles, a movable tubular carriage mechanism 51 is provided. This feeds three nozzles 52 spread along the length of the substantially horizontal carriage mechanism 51. The carriage is divided into two channels, the upper half 53 feeding temperature controlled air under pressure, during the drying process. The lower half 54 feeds temperature controlled water under pressure to the lower half of the nozzles during the showering process.

25

30

The carriage mechanism is supported on three vertical tracks 55 which have adjustable stops 56 to enable the user to select a maximum height of movement of the nozzles. This means that the person can choose to avoid washing and drying their head, or can choose

35

to sit down on a stool (not shown) during washing and/or drying. Automatically controlled pulley mechanisms 57 are provided to raise and lower the carriage 51 repeatedly so that substantially all parts of the user's body can receive direct spraying from at least one of the nozzles during the showering process, and a direct blast of drying air during the drying process. A drive means 58 provided for moving the carriage means 51 in reciprocating fashion can be constituted by electric motors provided with automatic reversing control, and transmission via drive belts or chains for example.

Air and water connections to the carriage bar can be provided at either end or both ends.

Figure 6 shows a plan view showing how the carriage 51 and nozzles 52 can be curved to extend around two or three sides of the user. Optionally the carriage could be completely circular to provide nozzles on all sides of the user. It would then have to be lowered over the users head when he or she is in the housing unit.

Figure 7 shows a cross-section of a dual channel nozzle on the right hand side, and a dual channel carriage 51 on the left hand side. The upper channel 53 is for air flow, and the lower channel 54 is for water flow. At the right hand side of Figure 7 can be seen vanes 62 in the upper channel for directing the air flow, while small holes 63 are shown in the lower part of the nozzle 52 for creating a spray of water during showering.

The nozzle 52 is shown as being removable from the carriage for easy maintenance. An overlap press fit joint 60 is provided, supplemented by a screw 61.

5 Figure 8 shows a schematic illustration of the gas or air directing means. Optionally sited above the user in a dome shaped casing 81, are shown a fan 82 and heating element 83. Drying air is ducted through fixed pipes 84 and flexible hosing 85 into the top  
10 channel of the carriage mechanism. The flexible hose 85 allows for movement of the carriage mechanism. A removable panel 86 is provided to gain access to the flexible hosing for maintenance purposes. Air pressure can be controlled by altering the fan speed  
15 using a control panel 87, and likewise drying air temperature can also be controlled manually. In addition, or as an alternative, a pre-programmed variation of drying temperature with time can be used to compensate for varying degrees of evaporation from  
20 the person which will thus cause varying degrees of cooling effect. The evaporation rate would also be dependent on the fan speed, and therefore temperature compensation should also be made for differing rates of fan speed.

25 Initially, when a user is still wet, higher air temperatures would be more comfortable, whereas as a user becomes drier, lower air temperatures should be used for maximum comfort. A suitable cooling curve  
30 can be predicted on this basis, and a preprogrammed temperature variation with time can be used to compensate accordingly and keep the person comfortable. The temperature control could also be dependent on air input temperature and/or humidity,  
35 or output air temperature and/or humidity.

Figure 9 shows a schematic diagram of the water supply to the carriage mechanism. Hot and cold inlet pipes 90 are shown leading to a mixer unit 91. Optionally an electric heating unit may be provided, along with a descaling inlet 92. A flexible hose 93 connects the mixer to the movable carriage, and a servicing panel 94 is provided to give access for maintenance purposes. A manual control knob to vary water temperature should also be provided.

10

The enclosure can be moulded from fibreglass, a plastics material, another lightweight material, or possibly all or partly of glass. The tracks, carriage, fan and nozzles can be advantageously formed from plastics materials or metals of suitable strengths.

The enclosure could be circular or correspond to the shape of a sitting human body, or could be made of flexible material to hug the body but allow some movement.

Optionally, multiple fans could be used in place of nozzles to direct air to various parts of the body.

25

Optionally, an air extractor can be provided (not shown). Also optionally there is provided a perforated base. The user can stand on this base and water draining from him will pass through the base during the showering process. During the drying process air may be passed up through the perforated base in order to dry the feet and lower legs of the user.

35 Another alternative is to place the tracks to allow movement of the nozzles diagonally or sideways.

Even without considering the washer, the following advantages are obtained. Firstly, drying can be achieved with minimum physical effort since towels are not necessary. This makes the unit particularly  
5 suitable for frail people. It also leads to advantages of improved hygiene, improved efficiency in effort and cost through avoiding cleaning of towels, and also improved safety since less movement is required by frail people or their nurses.

10 Secondly, the drying process is considerably more comfortable due to the compensated temperature control, and due to reduced physical effort requirements. This will therefore encourage frail  
15 people for whom washing and drying previously involved considerable effort and discomfort.

Considering the washer, the provision of multiple shower nozzles which are movable so that a spray is  
20 directed onto substantially all the body of the user at some point during the shower, achieves a better cleaning action more efficiently and with reduced requirement for physical effort on the part of the user or a person caring for the user. Water  
25 consumption is reduced, and if the user prefers not to have their face or hair sprayed, end stops can be positioned to restrict the movement of the carriage to only a region from the neck downwards. This also improves the comfort and convenience for the user.

30 The use of dual purpose nozzles allows the same mechanism to be used to move the water jets and the air jets , and thus makes for a simpler and cheaper construction.

35



Possible users of the washer/dryer include higher income households, hospitals, nursing homes, sports centres, swimming baths, physiotherapists, hotels. It could also be very helpful to the nursing profession, miners, athletes, the elderly and people recuperating from illness or operations.

The concept evolved as a solution to problems (observed by the Inventor) relating to elderly people and those suffering long-term illness. The difficulties encountered by nurses in bathing elderly and physically handicapped people are all too familiar e.g. lifting and the danger of patients slipping in baths. Many in this same group dislike showers which obliterate proper sight. Moreover, use of a shower head by hand is difficult for those who cannot reach behind their backs. Shivering whilst drying is another factor which makes some elderly people nervous. The described washer/dryer solves all of these problems.

Furthermore, ladies can save their hairstyles, little of no use of towels is necessary, the handrail provided prevents slipping and children will enjoy using it. Adjustable nozzle heights make this device ideal for all ages.

By washing and drying the bather this device successfully eliminates the discomfort lapse between present methods of washing/showering and drying. The upward and downward movement of water and air jets provides instant control of spray direction, need not wet the hair, and is also therapeutic.

The direction of water jets has a beneficial gently massaging effect upon the body.

5 The device can dry the body thoroughly with little demand on physical energy and can also keep the bather warm in cold weather and cool in hot weather.

10 The elliptical shape is particularly useful to aid even distribution from air and water jets. The simple stop device decides the highest limit for nozzles. Thereby, jets can reach hair level or not and can be lowered for short people, elderly people who may need to sit, and children.

15 The washer/dryer is hygienic, environment-friendly, compact and pleasing to use. It fits neatly into the corner of a bathroom for those who can afford it, but its potential for use in hospitals, old people homes, gym clubs and hotels is also enormous.

20 It could be made in at least two forms: 1) a dryer only model and, 2) a shower and dryer model.

25 The two processes of washing and drying can be successfully combined in comfort. The controlled water flow would be more enticing to children and the elderly who dislike water covering their heads. A significant saving on water consumption and of paper used for disposable towels also follow.

30

35

CLAIMS

5 1. A dryer for a human or animal body comprising a plurality of gas directing means, for directing a drying gas at various parts of the body simultaneously.

10 2. A dryer for a human or animal body comprising a gas directing means and drive means for moving the gas directing means to direct a drying gas at various parts of the body.

15 3. A dryer for a human or animal body comprising an enclosure substantially corresponding to the dimensions of the body to be dried leaving sufficient separation between body and enclosure for gas flow, and means for directing a drying gas through the enclosure.

20 4. A dryer according to claim 1 or claim 3, wherein said gas directing means is movable.

25 5. A dryer according to any of claims 1 to 4, wherein said gas directing means comprises a fan.

6. A dryer according to any of claims 1 to 5, wherein said gas directing means comprises a nozzle.

30 7. A dryer according to any of claims 1 to 6, wherein said gas directing means comprises a carriage.

8. A dryer according to claim 7, wherein said carriage is movable on a track.

35

9. A dryer according to claim 8, wherein said track extends vertically, diagonally or horizontally.

5 10. A dryer according to claim 8 or claim 9, wherein said track has an adjustable stop to limit the extent of movement.

10 11. A dryer as claimed in any of claims 7 to 10, wherein said carriage extends horizontally around at least 2 sides of a user.

15 12. A dryer according to any of claims 7 to 11, wherein at least two nozzles are connected to the carriage.

20 13. A dryer as claimed in any preceding claim, further comprising a perforated base to drain water dripping from a user, and means for directing drying gas at the feet of a user.

25 14. A dryer as claimed in claim 1, claim 2 or claim 4 or any claim depending on these claims, further comprising an enclosure having a substantially elliptical plan view cross section.

30 15. A dryer according to claim 2 or any claim when dependent on claim 2, wherein the drive means comprises an electric motor and chain or belt transmission.

35 16. A dryer according to claim 2 or any claim when dependent on claim 2, or claim 15, wherein the drive means is controlled so as to move the gas directing means in reciprocating fashion.

17. A washer/dryer, comprising a dryer as claimed in any preceding claim, and further comprising a shower unit having a nozzle for directing water at a user.

5

18. A washer/dryer for a human or animal body comprising an enclosure,

a shower unit assembly for washing the body in the enclosure, and

10

a dryer comprising means for directing a drying gas through the enclosure.

15

19. A washer/dryer according to claim 17 or claim 18, comprising a dual purpose nozzle operable to spray water or to direct a drying gas at a user.

20

20. A washer/dryer according to claim 19, wherein said nozzle comprises separate channels and outlets for water and drying gas.

25

21. A washer/dryer according to claim 17, when dependent on claim 7, wherein said carriage has separate ducts for water and drying gas.

30

22. A shower unit having a nozzle for directing water at a user, and a drive means for moving the nozzle relative to the user to direct water at various parts of the user.

35

23. A shower unit as claimed in claim 22, further comprising a track for mounting said nozzle, so as to allow movement along the track.

24. A shower unit as claimed in claim 23 or 24, further comprising a plurality of nozzles directed at at least two sides of a user.

25. A shower unit as claimed in any of claims 22 to 24, further comprising at least one adjustable stop for limiting movement of the nozzle or nozzles.

5 26. A method of drying a human or animal body comprising the step of directing a drying gas at various parts of the body simultaneously using a plurality of gas directing means.

10 27. A method of drying a human or animal body comprising the steps of using a gas directing means to direct a drying gas at the body, and moving the gas directing means to direct the gas at various parts of the body using a drive means.

15 28. A method of drying a human or animal body comprising the step of:

directing a drying gas through an enclosure surrounding the body, the dimensions of the enclosure  
20 corresponding substantially to the dimensions of the body.

29. A method of washing and drying a human or animal body comprising the steps of spraying water at  
25 the body, within an enclosure, followed by the steps of any of claims 24 to 27.

30. A method of washing a human or animal body comprising the steps of:

30 spraying water through a nozzle at one part of the body;

moving the nozzle using a drive means so as to direct water at different parts of the body.

35

31. A dryer substantially as hereinbefore described with reference to the Figures.

5 32. A washer/dryer substantially as hereinbefore described with reference to the Figures.

33. A shower unit substantially as hereinbefore described with reference to the Figures.

10 34. A method of washing substantially as hereinbefore described with reference to the Figures.

15 35. A method of washing and drying substantially as hereinbefore described with reference to the Figures.

15

20

25

30

35

Relevant Technical fields

- (i) UK CI (Edition L) A4V
- (ii) Int CI (Edition 5) A47K 10/48

Search Examiner

N FRANKLIN

Databases (see over)

- (i) UK Patent Office
- (ii)

Date of Search

15 FEBRUARY 1993

Documents considered relevant following a search in respect of claims 1, 4-14, 17, 19-21 (as dep on Claim 1), 26

Category (see over)	Identity of document and relevant passages	Relevant to claim(s)
X	GB 2243546 A (PHILIPS) Note Figure 1 and movable shower head 4	1, 26 at least
X	GB 2222944 A (GRANVILLE) Note Figure 3	1, 26 at least
X	GB 2146522 A (COLLINS) Note dryer unit of Figure 1	1, 26 at least
X	GB 2020970 A (MANNALL) Note Claims 1 and 17	1, 26 at least
X	US 3878621 A (DUERRE) Note column 4 lines 14-42	1, 26 at least



Category	Identity of document and relevant passages	Relevant to claim(s)

**Categories of documents**

X: Document indicating lack of novelty or of inventive step.

Y: Document indicating lack of inventive step if combined with one or more other documents of the same category.

A: Document indicating technological background and/or state of the art.

P: Document published on or after the declared priority date but before the filing date of the present application.

E: Patent document published on or after, but with priority date earlier than, the filing date of the present application.

&: Member of the same patent family, corresponding document.

**Databases:** The UK Patent Office database comprises classified collections of GB, EP, WO and US patent specifications as outlined periodically in the Official Journal (Patents). The on-line databases considered for search are also listed periodically in the Official Journal (Patents).