



US00D351817S

United States Patent [19]

[11] Patent Number: **Des. 351,817**

Lewellen et al.

[45] Date of Patent: **** Oct. 25, 1994**

[54] **UTILITY TRUCK BODY**

[56] **References Cited**

[75] Inventors: **Richard Lewellen; George Kalis, Jr.; Robert M. Lapsley**, all of Wooster, Ohio

U.S. PATENT DOCUMENTS

D. 190,416	5/1961	Powers	D12/96
3,596,976	8/1971	Eitel	296/24.1
4,126,349	11/1978	Nelson et al.	296/24.1
4,685,695	8/1987	LeVee	296/24.1

[73] Assignee: **Stahl/Scott Fetzer Company**, Wooster, Ohio

Primary Examiner—James M. Gandy
Attorney, Agent, or Firm—Watts, Hoffmann, Fisher & Heinke

[**] Term: **14 Years**

[57] **CLAIM**

The ornamental design for a utility truck body, as shown and described.

[21] Appl. No.: **3,247**

DESCRIPTION

[22] Filed: **Jan. 4, 1993**

FIG. 1 is a perspective view of a utility truck body showing our new design;
 FIG. 2 is a left-side elevation view thereof, the right-side elevation view being a mirror image thereof;
 FIG. 3 is a rear elevational view thereof;
 FIG. 4 is a front elevational view thereof;
 FIG. 5 is a top plan view thereof; and,
 FIG. 6 is a bottom plan view thereof.

The broken line showing of a pickup truck in FIGS. 1, 2, 3, 5 and 6 of the drawings is for illustrative purposes only and forms no part of the claimed design.

Related U.S. Application Data

[63] Continuation-in-part of Ser. No. 915,957, Jul. 20, 1992, Pat. No. Des. 346,571.

[52] U.S. Cl. **D12/98**

[58] Field of Search 296/24.1, 37.6, 183; D12/98, 14

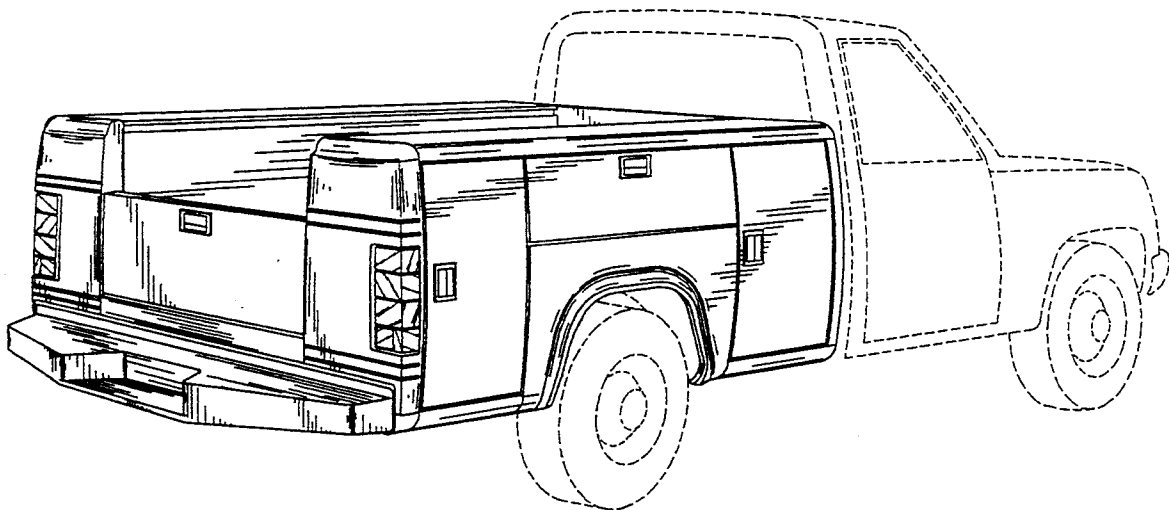

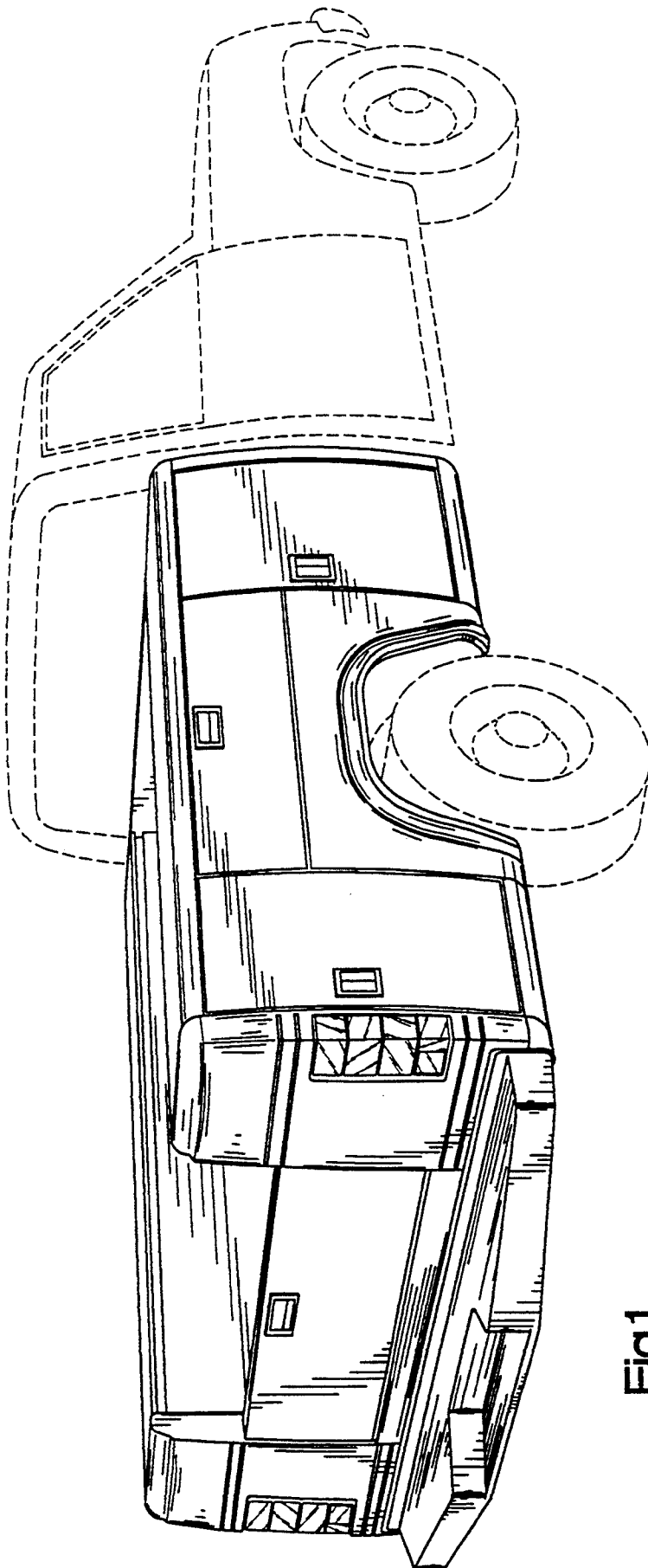

Fig.1

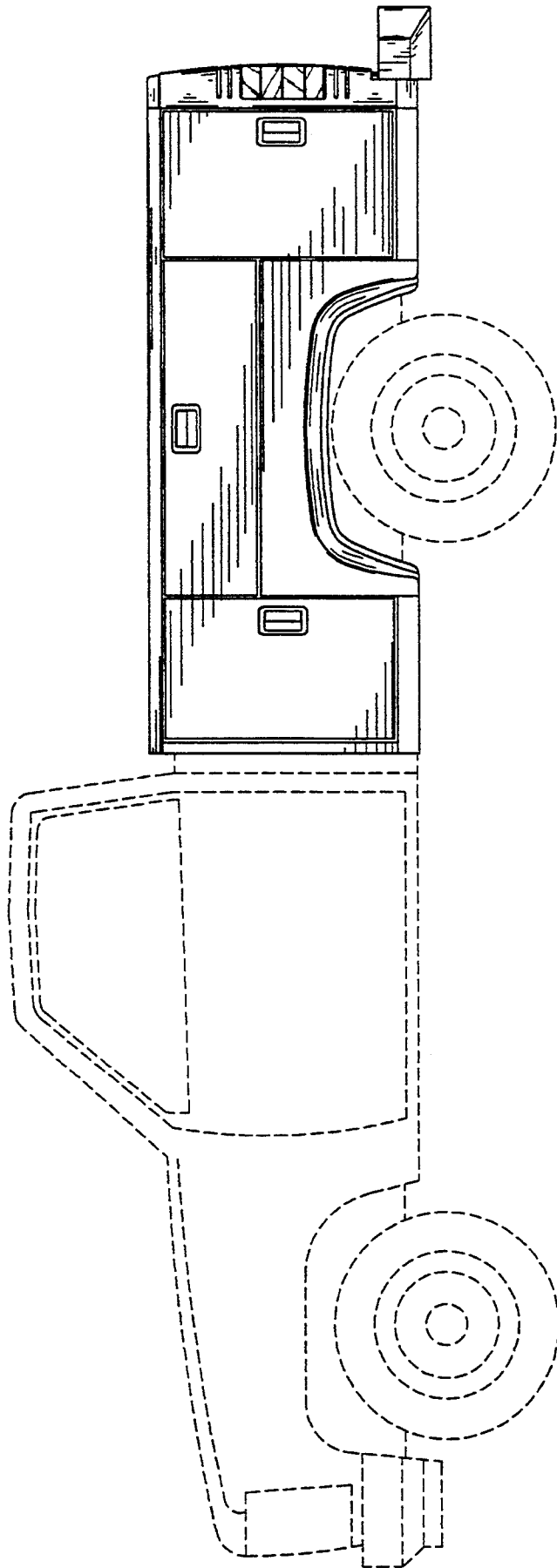

Fig.2

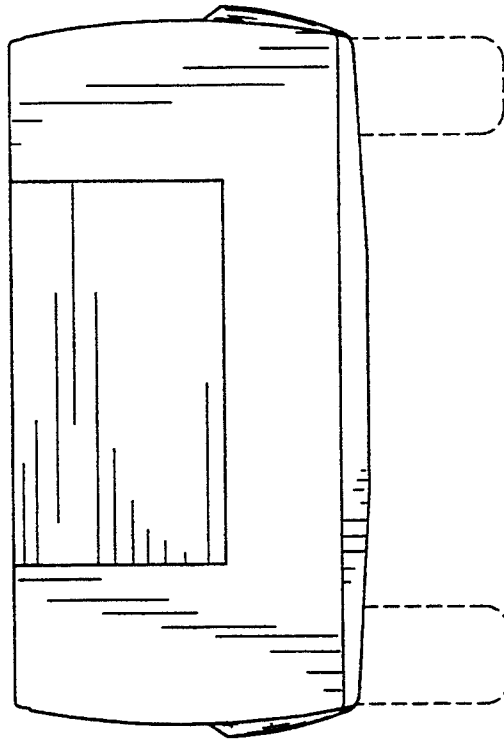

Fig.4

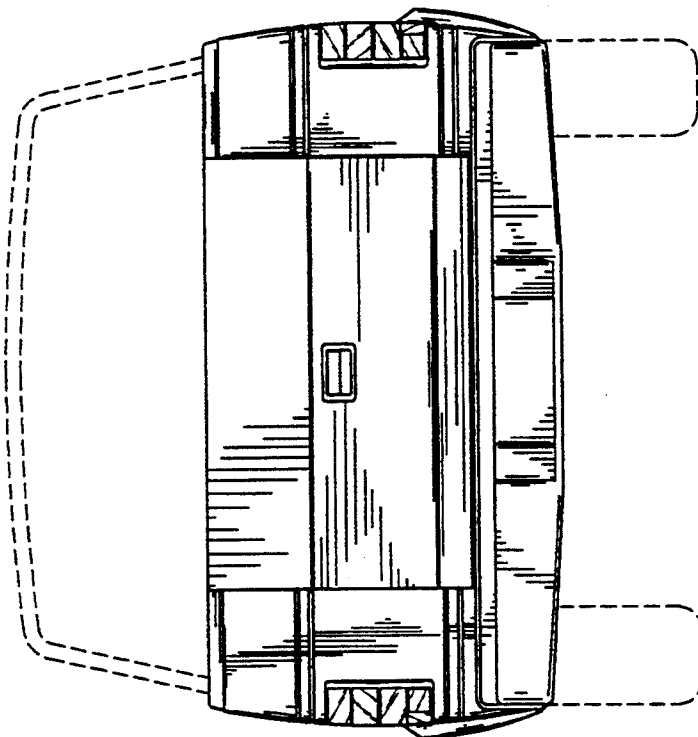

Fig.3

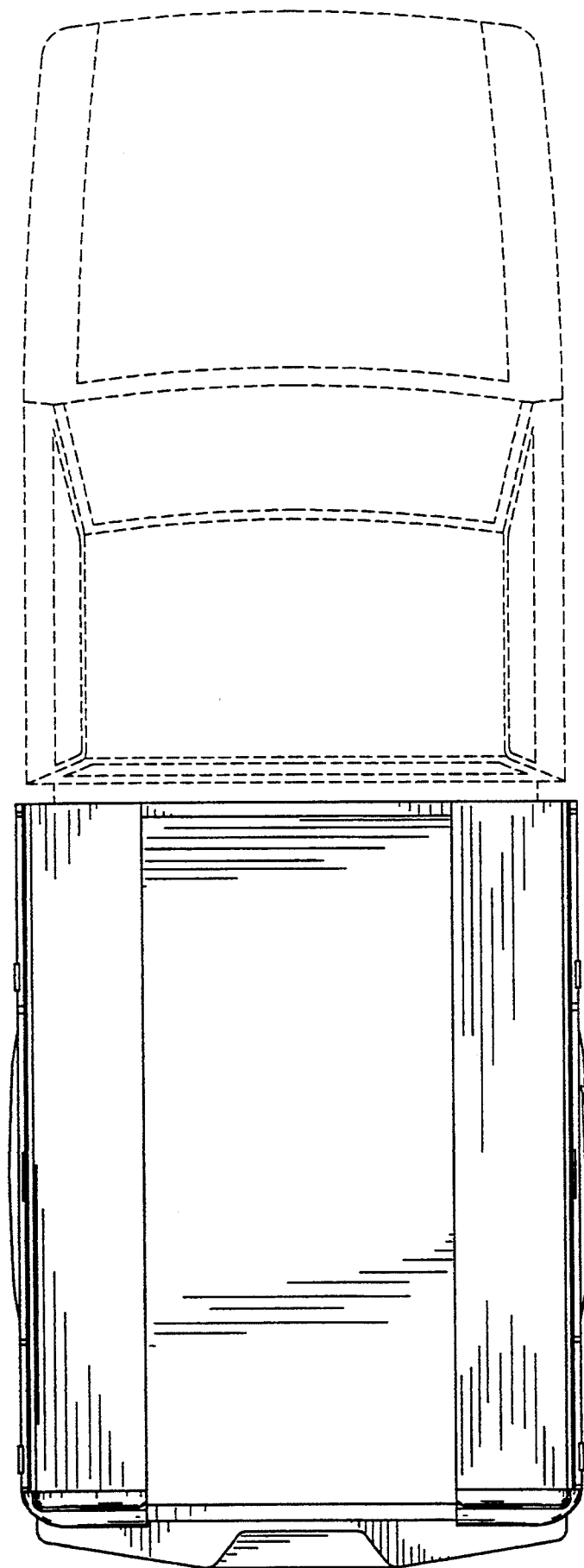

Fig.5

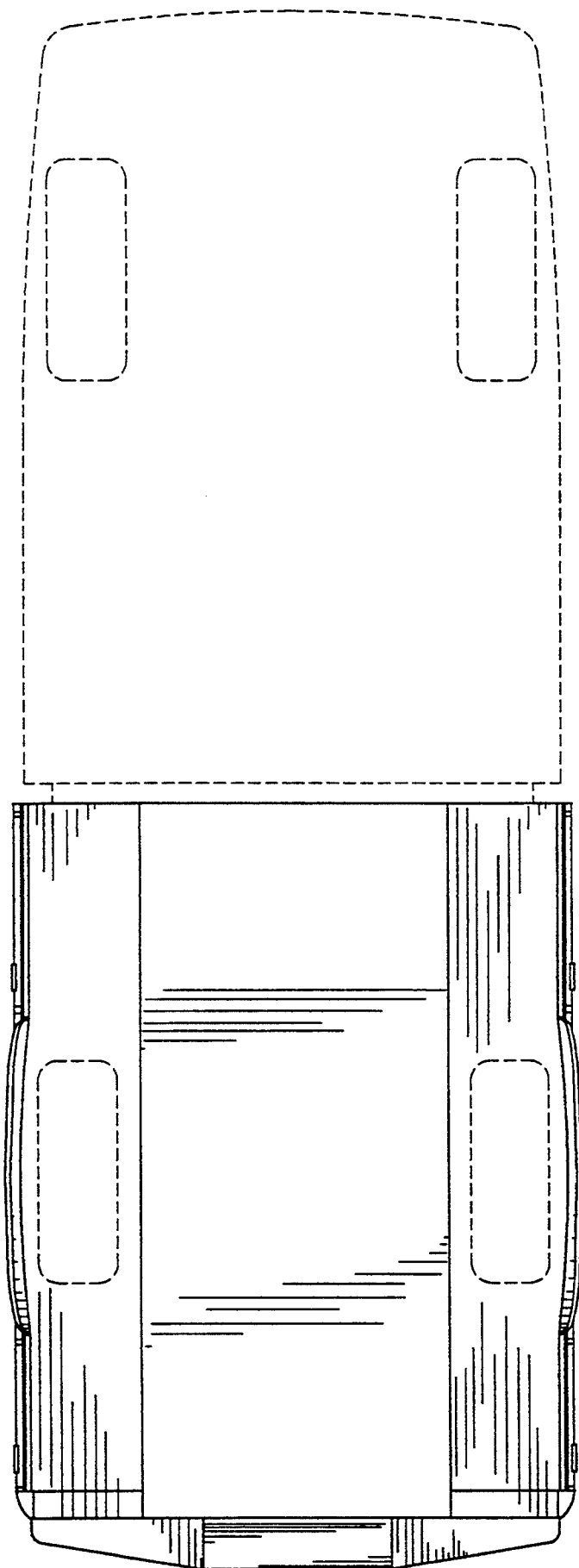

Fig.6