



- (51) International Patent Classification:
A01J 5/08 (2006.01)
- (21) International Application Number:
PCT/US2014/054681
- (22) International Filing Date:
9 September 2014 (09.09.2014)
- (25) Filing Language: English
- (26) Publication Language: English
- (30) Priority Data:
14/039,998 27 September 2013 (27.09.2013) US
- (71) Applicant: GEA FARM TECHNOLOGIES, INC.
[US/US]; 1880 Country Farm Drive, Naperville, Illinois 60563 (US).
- (72) Inventors: HEDLUND, Nathan; 115 Nicholas Drive, Lewiston, Minnesota 55952 (US). THORNTON, Terry; 20903 W. Gale Ave., Galesville, Wisconsin 54630 (US).
- (74) Agent: SMITH, Jeffrey W.; 8517 Excelsior Drive, Suite 402, Madison, Wisconsin 53717 (US).

- (81) Designated States (unless otherwise indicated, for every kind of national protection available): AE, AG, AL, AM, AO, AT, AU, AZ, BA, BB, BG, BH, BN, BR, BW, BY, BZ, CA, CH, CL, CN, CO, CR, CU, CZ, DE, DK, DM, DO, DZ, EC, EE, EG, ES, FI, GB, GD, GE, GH, GM, GT, HN, HR, HU, ID, IL, IN, IR, IS, JP, KE, KG, KN, KP, KR, KZ, LA, LC, LK, LR, LS, LU, LY, MA, MD, ME, MG, MK, MN, MW, MX, MY, MZ, NA, NG, NI, NO, NZ, OM, PA, PE, PG, PH, PL, PT, QA, RO, RS, RU, RW, SA, SC, SD, SE, SG, SK, SL, SM, ST, SV, SY, TH, TJ, TM, TN, TR, TT, TZ, UA, UG, US, UZ, VC, VN, ZA, ZM, ZW.
- (84) Designated States (unless otherwise indicated, for every kind of regional protection available): ARIPO (BW, GH, GM, KE, LR, LS, MW, MZ, NA, RW, SD, SL, ST, SZ, TZ, UG, ZM, ZW), Eurasian (AM, AZ, BY, KG, KZ, RU, TJ, TM), European (AL, AT, BE, BG, CH, CY, CZ, DE, DK, EE, ES, FI, FR, GB, GR, HR, HU, IE, IS, IT, LT, LU, LV, MC, MK, MT, NL, NO, PL, PT, RO, RS, SE, SI, SK, SM, TR), OAPI (BF, BJ, CF, CG, CI, CM, GA, GN, GQ, GW, KM, ML, MR, NE, SN, TD, TG).

Published:
— with international search report (Art. 21(3))

(54) Title: ANTI-TWIST LINER AND SHELL FOR A DAIRY ANIMAL TEAT CUP ASSEMBLY

Fig. 7

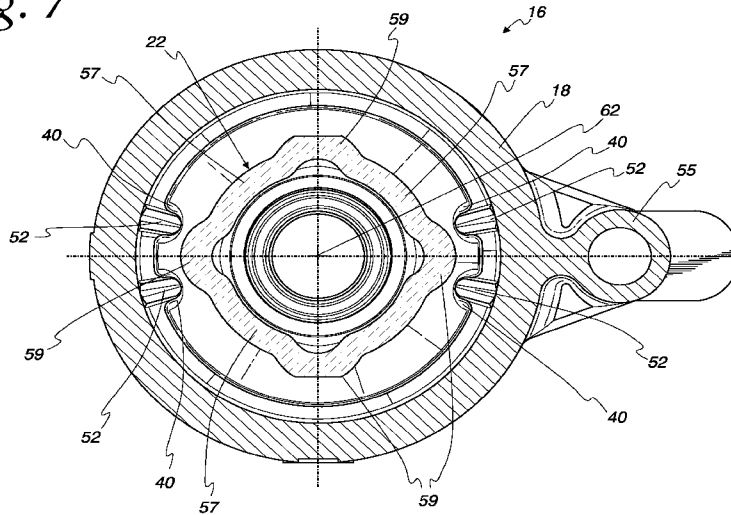

(57) Abstract: A milker unit teat cup assembly (16) for dairy animals having a shell (18) and liner (22) combination that resists twisting by the liner barrel relative to the shell using a recess (40) in the liner (22) that is engaged by a key (52) in the shell (18).

WO 2015/047714 A1

ANTI-TWIST LINER AND SHELL FOR A DAIRY ANIMAL TEAT CUP ASSEMBLY**FIELD AND BACKGROUND OF THE INVENTION**

[0001] This invention relates generally to milker units for milking dairy animals, and more particularly to a milker unit shell and liner combination that resists twisting of the liner relative to the shell.

[0002] Milker units for milking dairy animals include a shell and liner in a teat cup assembly that attaches to a dairy animal teat. The liner fits inside the shell and a vacuum chamber is defined between the shell and the liner. A pulsating vacuum is applied to the vacuum chamber to move the liner in and out of compression (massaging) contact with a dairy animal teat that is in the liner. The pulsating vacuum in the pulsation chamber is opposed by a constant vacuum inside of the liner. The pulsating vacuum is applied through a pulsation connection in the side of the shell and the constant vacuum is applied through a milk hose connected to the liner. The milk hose vacuum also draws milk from the liner into a short milk tube, milking claw, and collection bowl, through a long milk tube, and into a milk collection system.

[0003] The shell and liner are fitted together in a coaxial relationship and a mouthpiece of the liner fits over the top of the shell so that the mouthpiece, and not the shell, contacts the animal. The mouthpiece provides a vacuum seal against the teat and udder of the animal being milked. The liner also includes a barrel joined to the mouthpiece and into which the animal's teat extends during milking. The teat is massaged by the liner barrel by the pulsating vacuum. Various barrel designs have been developed to improve cow comfort and milking efficiency.

[0004] A lower end of the liner barrel extends out of a hole in the lower end of the shell. The liner barrel typically includes a locking ring that is pulled through the shell hole during assembly, so that the locking ring is outside of the shell when the liner is installed.

[0005] The liner is adequately secured in the shell because the upper mouthpiece of the liner is engaged with an upper end of the shell, and the locking ring of the liner is engaged with a lower end of the shell. In a typical shell and liner assembly, the liner will even be somewhat tensioned in an axial direction because of the opposing engagements at the top and bottom of the shell.

[0006] Extending downstream from the liner is a short milk tube that can be joined to or formed with the liner. For a variety of reasons, the short milk tube can be twisted and that twisting can cause the liner barrel to twist as well. The twisting of the short milk tube can be intentional to close the vacuum line when a dairy operator decides to leave a teat cup assembly off a dairy animal because there is no teat or the teat is injured or otherwise too unhealthy to be milked. Other forces can twist the short milk tube, so it is not uncommon for liner barrel to be twisted as well. When the liner barrel twists, it is possible that the seal with the dairy animal can fail or it can otherwise inhibit efficient milking and milking operations.

[0007] Previous liners have been designed that include ribs or flanges that are fitted into slots during insertion of the liner into the shell. Some of these designs are used to control collapse of the liner barrel into a predetermined shape, but they can also help prevent twisting. Typically, these designs are relatively expensive to manufacture and time-consuming to install. Since liners are replaced periodically, the added cost for such designs is cumulative and relatively expensive.

[0008] Thus, there is needed a relatively inexpensive shell and liner assembly that reduces twisting of the liner inside the shell while maintaining good sealing contact with the animal being milked and efficiency of the milking process.

SUMMARY OF THE INVENTION

[0009] To provide a cost-effective anti-twist shell liner, there is provided in accordance with the present invention a milker unit shell liner having: a mouthpiece defining a teat opening; a barrel

joined to the mouthpiece, and defining a bore and a longitudinal axis aligned with the teat opening; and the barrel defines an alignment recess radially spaced apart from the longitudinal axis of the barrel. Preferably, the barrel includes, a lower locking ring joined to a lower portion of the barrel and extending radially outwardly from the barrel; and an upper locking ring joined to the lower portion of the barrel, extending radially outwardly from the barrel, and spaced apart from the lower locking ring to define a shell-engaging annular recess, and the upper locking ring defines the alignment recess. The alignment recess can open radially outwardly and be open to the annular recess.

[0010] The barrel can further define a second alignment recess spaced apart from the first alignment recess, to form a first pair of alignment recesses; and a second pair of alignment recesses spaced apart from the first pair of alignment recesses. The second pair of alignment recesses can be spaced diametrically opposite from the first pair of alignment recesses.

[0011] The milker unit shell liner can include a short milk tube joined to the barrel and define a milk bore substantially aligned with the barrel bore. The short milk tube can also define an air vent.

[0012] Also in accordance with the present invention, there is provided a milker unit teat cup assembly, having a liner that includes: a mouthpiece defining a teat opening; a barrel joined to the mouthpiece, and defining a longitudinal axis aligned with the teat opening; and a lower locking ring joined to a lower portion of the barrel and extending radially outwardly from the barrel. The barrel can include an upper locking ring joined to the lower portion of the barrel, extending radially outwardly from the barrel, and spaced apart from the lower locking ring to define a shell-engaging annular recess, and the barrel, particularly the upper locking ring, defines an alignment recess spaced radially outwardly from the longitudinal axis of the barrel; and a

shell into which the shell liner is disposed, and the shell defines a lower opening with an inward annular edge disposed in the annular recess between the lower locking ring and the upper locking ring in the shell liner, and a key disposed in the alignment recess. As in the embodiment described above, the alignment recess can open radially outwardly and be open to the annular recess.

[0013] The barrel, and preferably the upper locking ring can further define a second alignment recess spaced apart from the first alignment recess to form a first pair of alignment recesses; and a second pair of alignment recesses can be spaced apart from the first pair of alignment recesses. The second pair of alignment recesses can be spaced diametrically opposite from the first pair of alignment recesses.

BRIEF DESCRIPTION OF THE DRAWINGS

[0014] Fig. 1 is a side cross-sectional view of a teat cup assembly in accordance with the present invention;

[0015] Fig. 2 is a perspective view of a teat cup assembly shell liner in accordance with the present invention;

[0016] Fig. 3 is a cross-sectional perspective view of a teat cup assembly shell in accordance with the present invention;

[0017] Fig. 4 is a cross-sectional view of the shell taken along line 4-4 of Fig. 3.

[0018] Fig. 5 is a detailed side view of the liner of Fig. 2 and illustrating a pair of alignment recesses in accordance with the present invention;

[0019] Fig. 6 is a cross-sectional view of the liner taken along line 6-6 in Fig. 5, and

[0020] Fig. 7 is a cross-sectional view of the teat cup assembly taken along line 7-7 in Fig. 1.

DETAILED DESCRIPTION OF THE DRAWINGS

[0021] In the following detailed description of the drawings the same reference numeral will be used to identify the same or similar elements in each of the figures. Depicted in Fig. 1 is a cross-sectional view of a teat cup assembly 16, in accordance with the present invention, including a shell 18 and a shell liner 22. The shell liner 22 includes a mouthpiece 24 defining a teat opening 26, a barrel 28 joined to the mouthpiece 24 and extending downwardly as depicted, an upper locking ring 30, and a lower locking ring 32 spaced apart from the upper locking ring to define a shell-engaging annular recess 36. The upper locking ring 30 defines a number of alignment recesses 40.

[0022] The liner 22 can also include an integral short milk tube 41 joined to the barrel 28 and having a teat claw connecting end 43. The short milk tube 41 is an optional extension of the liner 22, and in other embodiments, the short milk tube 41 can be a separate item that connects to a lower end of the liner 22.

[0023] As illustrated in Figs. 1, 3, and 4 the shell 18 includes an upper end 44, an upper opening 46, a lower end 48 defining a lower opening 50 with an inwardly directed annular edge 51, and keys 52 that are provided in a number, size, and arrangement to mate with the alignment recesses 40. The shell 18 also includes a pulsation connector 55.

[0024] As depicted in Figs. 1, 2, 5, and 6, the liner 22 mouthpiece 24 can be of a type and shape described and depicted in U.S. Patent 8,113,145, which is incorporated herein by reference, but other mouthpiece shapes and sizes can be used with the present invention. As depicted in Figs. 1 and 2, the mouthpiece 24 generally includes an upper surface 54 that interfaces with a teat and udder of a dairy animal to form a comfortable seal that minimizes loss of vacuum from the inside of the liner through the teat opening 26. The mouthpiece 24 further includes a downwardly

extending skirt 56 that extends downward and is spaced apart from the barrel 28 so that an upper end of the shell (described below) can fit between the barrel 28 and the mouthpiece skirt 56, when assembled. The mouthpiece skirt 56 can include an alignment mark 58 to aid in assembly.

[0025] The barrel 28 defines a longitudinal axis 62 (Figs. 1, 6, and 7) and the barrel 28, itself, can have any desired cross-sectional shape including, round, oval, triangular, square, and the shape illustrated in Figs. 1, 2, and 5, for example. Typically, barrel 28 shape is selected to optimize animal comfort and milking efficiency. The barrel 28 illustrated herein has walls 57 and corners 59 (see Fig. 5, for example) that can be of uniform thickness or have varied thicknesses to control collapse of the barrel wall during pulsation and milking or for simplifying manufacturing. Any desired barrel cross-sectional shape can be used with the present invention.

[0026] The upper locking ring 30 (sometimes referred to as a “hackle” in the dairy industry) is part of the barrel 28, and is preferably used in the present invention together with the lower locking ring 32 to define the annular recess 36. The liner 22 is joined to the shell lower opening 50 at the inwardly directed annular edge 51 using the annular recess 36. (See Figs. 1 and 7.) This arrangement provides a secure connection between the liner 22 and shell 18, and due to friction, inhibits some level of twisting of the barrel 28 and the liner 22 relative to the shell 18. Nonetheless, twisting can still occur, so the barrel 28, and particularly the upper locking ring 30 of the liner 22, preferably defines two pairs of alignment recesses 40 to be engaged by the mating keys 52, in the shell 18. Although it is preferred to include the upper locking ring 30, it is not necessary, and the alignment recesses 40 can be formed in any part of the barrel 28, but preferably in the lower end of the barrel 28.

[0027] In the illustrated embodiment of Fig. 5, for example, the alignment recesses 40 are formed integrally or are cut or otherwise formed in the upper locking ring 30. As best seen in

Fig. 5, the upper locking ring 30 defines the alignment recesses 40 as a generally inverted U-shape with rounded shoulders 60 to enable a smoother assembly of the shell keys 52 into the alignment recesses 40. Also, for forming efficiency and to provide access for the keys 52 to enter the alignment recesses 40, it is preferred that the alignment recesses 40 open to the annular recess 36, as illustrated. To prevent twisting of the liner 22 relative to the shell 18, the alignment recess 40 should be radially spaced apart from a longitudinal axis of the barrel 28.

[0028] The drawings illustrate the alignment recesses 40 in two pairs with one pair on a diametrically opposed side from the other. Although the illustrated arrangement is preferred, other arrangements of alignment recesses 40 are possible. For example, a single alignment recess 40 can be used on an asymmetrical arrangement, particularly if a particular orientation of the liner 22 relative to the shell 18 is desired.

[0029] Similarly, the shell keys 52 can be provided to match the number of alignment recesses 40, or relatively fewer keys 52 can be provided. For example, two alignment recesses 40 and one key 52 can be used to make it easier to assemble the liner 22 into the shell 18.

[0030] The lower locking ring 32 preferably includes a rounded surface 63 against which the inwardly directed annular edge 51 of the lower end of the shell 18 will slide when the liner 22 is being installed in the shell 18. Once the liner 22 is installed, the inwardly directed annular edge 51 is releasably engaged with the liner's annular recess 36. Also, once the liner 22 is installed, it is preferably tensioned somewhat along the longitudinal axis 62, due to the relative size of the shell 18 and the liner 22. This is sometimes referred to as "pretensioning" and it improves liner performance.

[0031] The short milk tube 41 can define an alignment feature 66 raised above, which is seen as a vertical embossment on the short milk tube 41 in Fig. 2. An air vent 68 can also be provided

and its location relative to other milker unit components can be controlled using the present invention, if desired.

[0032] Preferably, the liner is made of silicone, but any other suitable liner material can be used.

[0033] The foregoing detailed description of the drawings is provided for a better understanding of the present invention. Nothing therein is intended to unduly limit the scope of the following claims and no unnecessary limitations should be read into the following claims.

CLAIMS

1. A teat cup assembly liner comprising:
a mouthpiece defining a teat opening; and
a barrel joined to the mouthpiece, and defining a bore and a longitudinal axis aligned with the teat opening; and the barrel defines a shell-engaging annular recess.
2. The teat cup assembly shell liner of claim 1, wherein the alignment recess opens radially outwardly.
3. The teat cup assembly shell liner of claim 1, and the barrel comprises:
a lower locking ring joined to a lower portion of the barrel and extending radially outwardly from the barrel; and
an upper locking ring joined to the lower portion of the barrel, extending radially outwardly from the barrel, and spaced apart from the lower locking ring to define an annular recess, and the alignment recess is formed in the upper locking ring.
4. The teat cup assembly shell liner of claim 3, wherein the alignment recess is open to the annular recess.
5. The teat cup assembly shell liner of claim 3, wherein the alignment recess opens radially outwardly and into the annular recess.
6. The teat cup assembly shell liner of claim 1, and the barrel further defines a second alignment recess spaced apart from the first alignment recess.

7. The teat cup assembly shell liner of claim 1, and the barrel further defines:
a second alignment recess spaced apart from the first alignment recess to form a first pair of alignment recesses; and
a second pair of alignment recesses spaced apart from the first pair of alignment recesses.
8. The teat cup assembly shell liner of claim 1, and the barrel further defines:
a second alignment recess spaced apart from the first alignment recess to form a first pair of alignment recesses; and
a second pair of alignment recesses spaced diametrically opposite from the first pair of alignment recesses.
9. The teat cup assembly shell liner of claim 1, and further comprising:
a short milk tube joined to the barrel and defining a milk bore substantially aligned with the barrel bore.
10. The teat cup assembly shell liner of claim 1, and further comprising:
a short milk tube joined to the barrel and defining a milk bore substantially aligned with the barrel bore, and defining an air vent.

11. A teat cup assembly, comprising:
 - a liner having:
 - a mouthpiece defining a teat opening;
 - a barrel joined to the mouthpiece, and defining a bore and a longitudinal axis aligned with the teat opening;
 - a lower locking ring joined to a lower portion of the barrel and extending radially outwardly from the barrel;
 - an upper locking ring joined to the lower portion of the barrel, extending radially outwardly from the barrel and spaced apart from the lower locking ring to define a shell-engaging annular recess, and the upper locking ring defines an alignment recess radially spaced apart from the longitudinal axis of the barrel; and
 - a shell into which the shell liner is disposed, and the shell defines a lower opening with an inward annular edge disposed in the annular recess between the lower locking ring and the upper locking ring in the shell liner, and the shell includes a key disposed in the alignment recess.
12. The teat cup assembly of claim 11, wherein the alignment recess opens radially outwardly.
13. The teat cup assembly of claim 11, wherein the alignment recess is open to the annular recess.
14. The teat cup assembly of claim 11, wherein the alignment recess opens radially outwardly and into the annular recess.
15. The teat cup assembly of claim 11, and the upper locking ring further defines a second alignment recess spaced apart from the first alignment recess.

16. The teat cup assembly of claim 11, and the upper locking ring further defines:
 - a second alignment recess spaced apart from the first alignment recess to form a first pair of alignment recesses; and
 - a second pair of alignment recesses spaced apart from the first pair of alignment recesses.
17. The teat cup assembly of claim 11, and the upper locking ring further defines:
 - a second alignment recess spaced apart from the first alignment recess to form a first pair of alignment recesses; and
 - a second pair of alignment recesses spaced diametrically opposite from the first pair of alignment recesses.
18. The teat cup assembly of claim 11, and further comprising:
 - a short milk tube joined to the barrel and defining a milk bore substantially aligned with the barrel bore.
19. The teat cup assembly of claim 11, and further comprising:
 - a short milk tube joined to the barrel and defining a milk bore substantially aligned with the barrel bore, and defining a vent.

1/7

Fig. 1

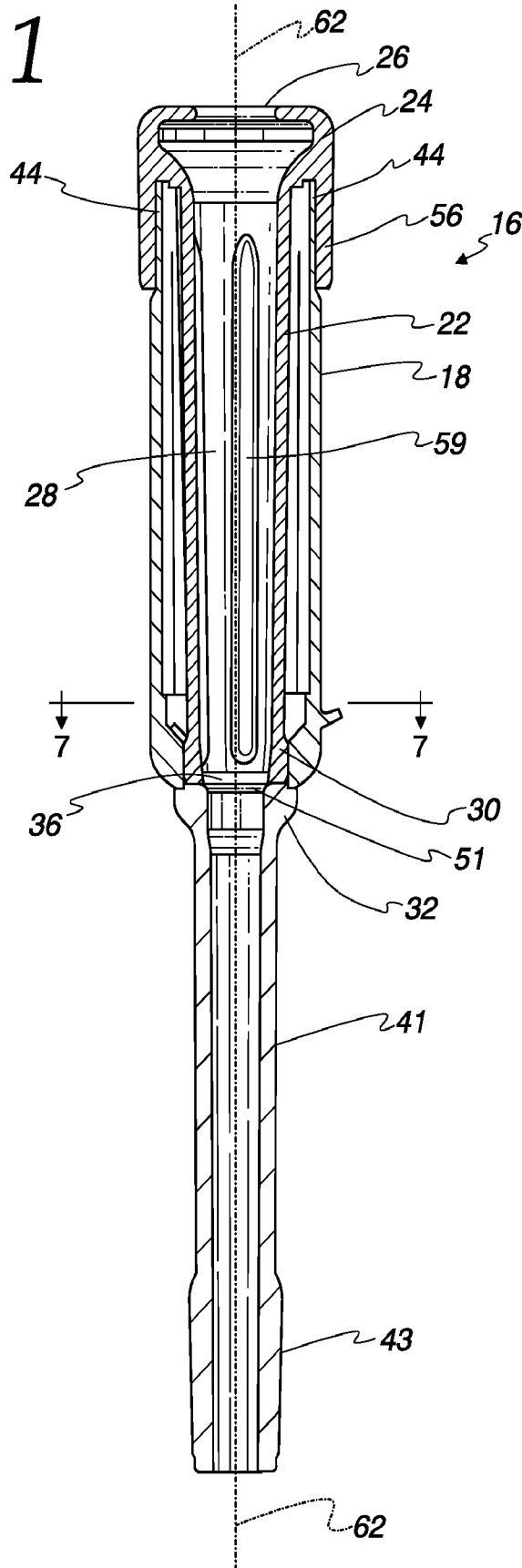

2/7

Fig. 2

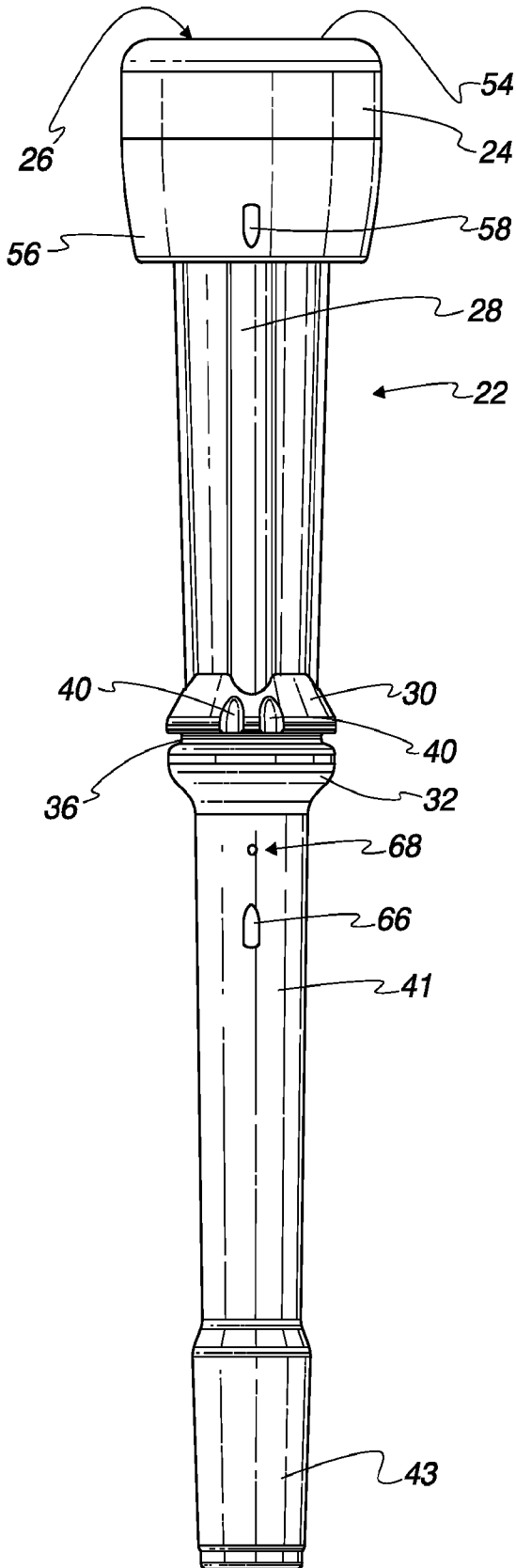

3/7

Fig. 3

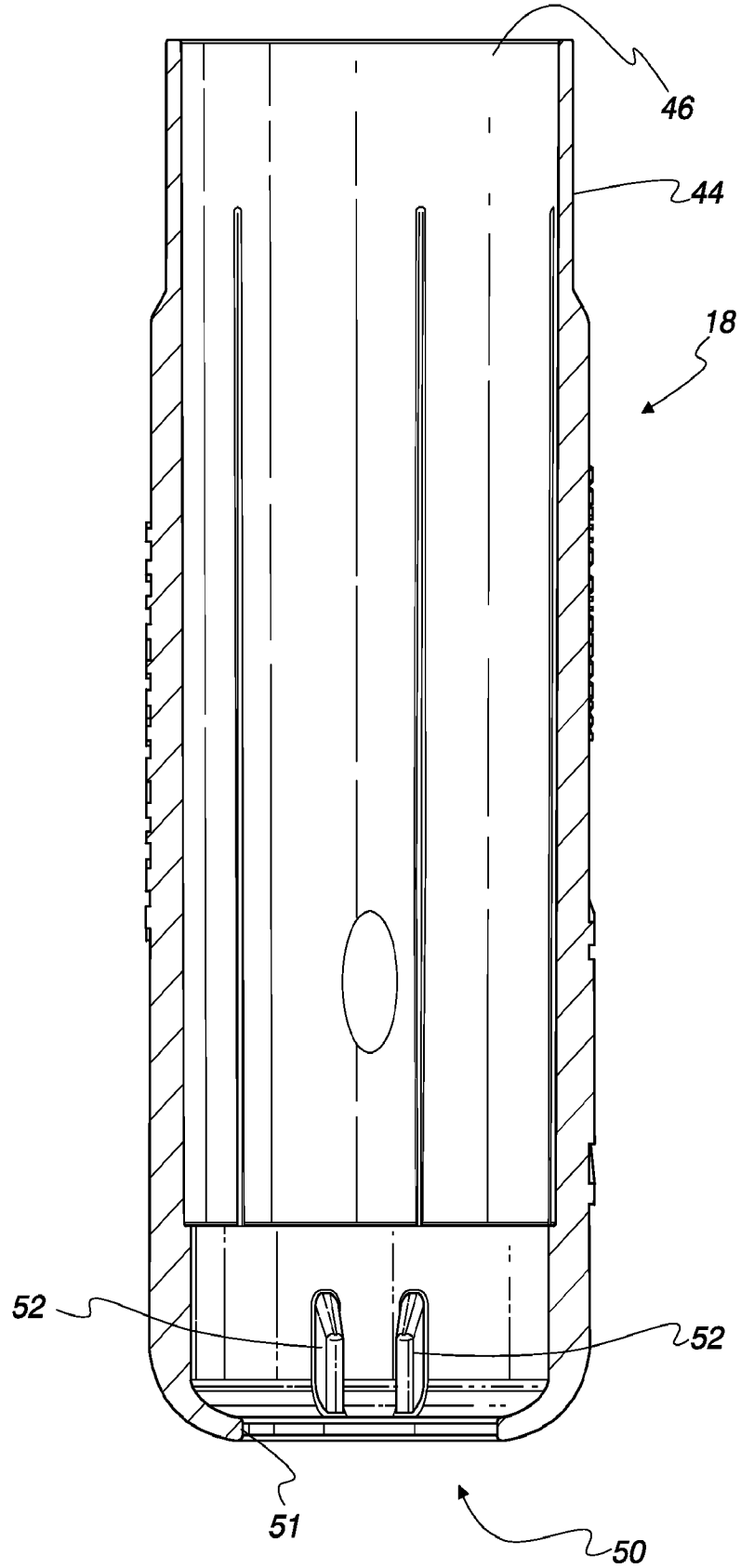

4/7

Fig. 4

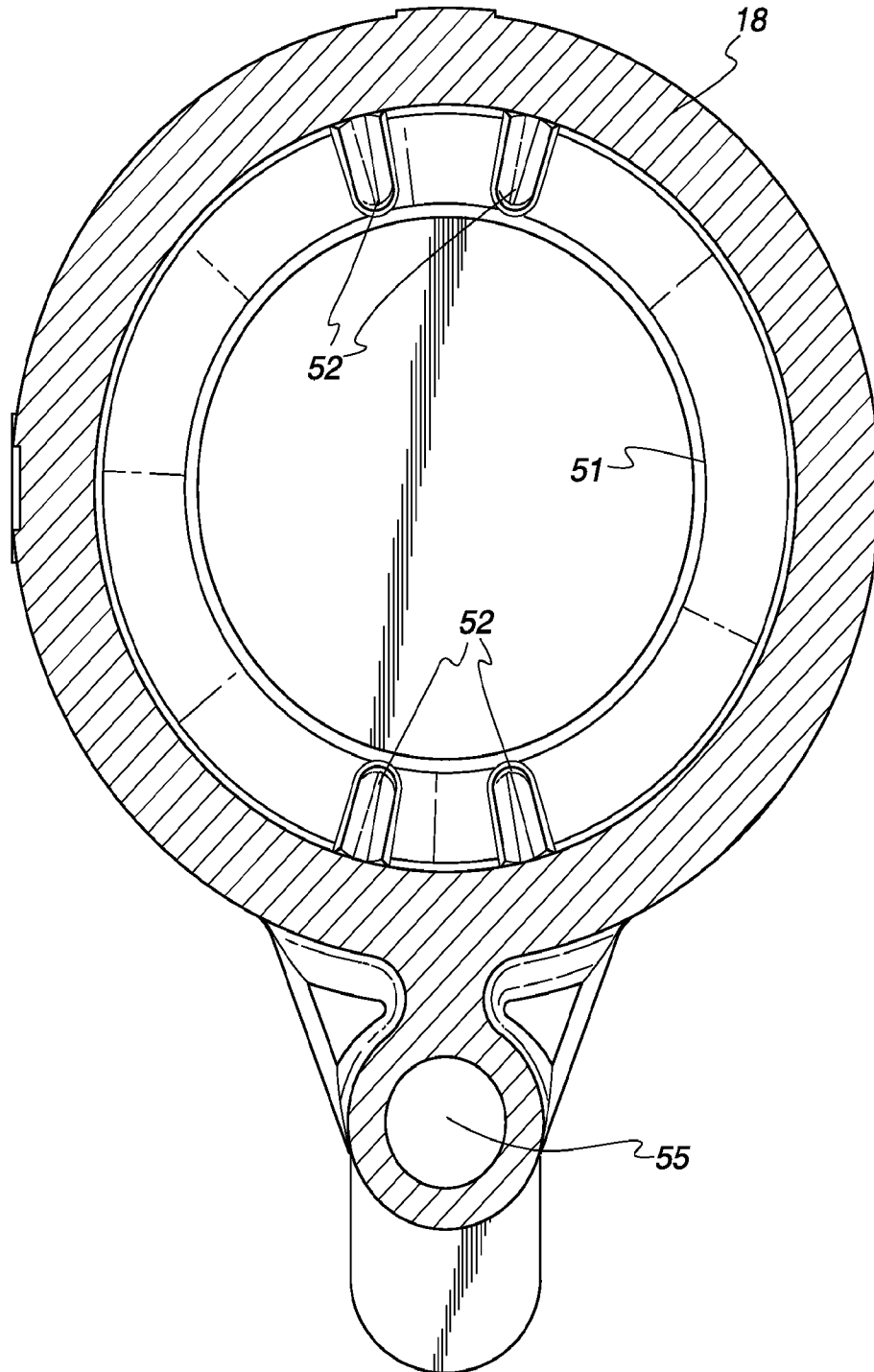

Fig. 5

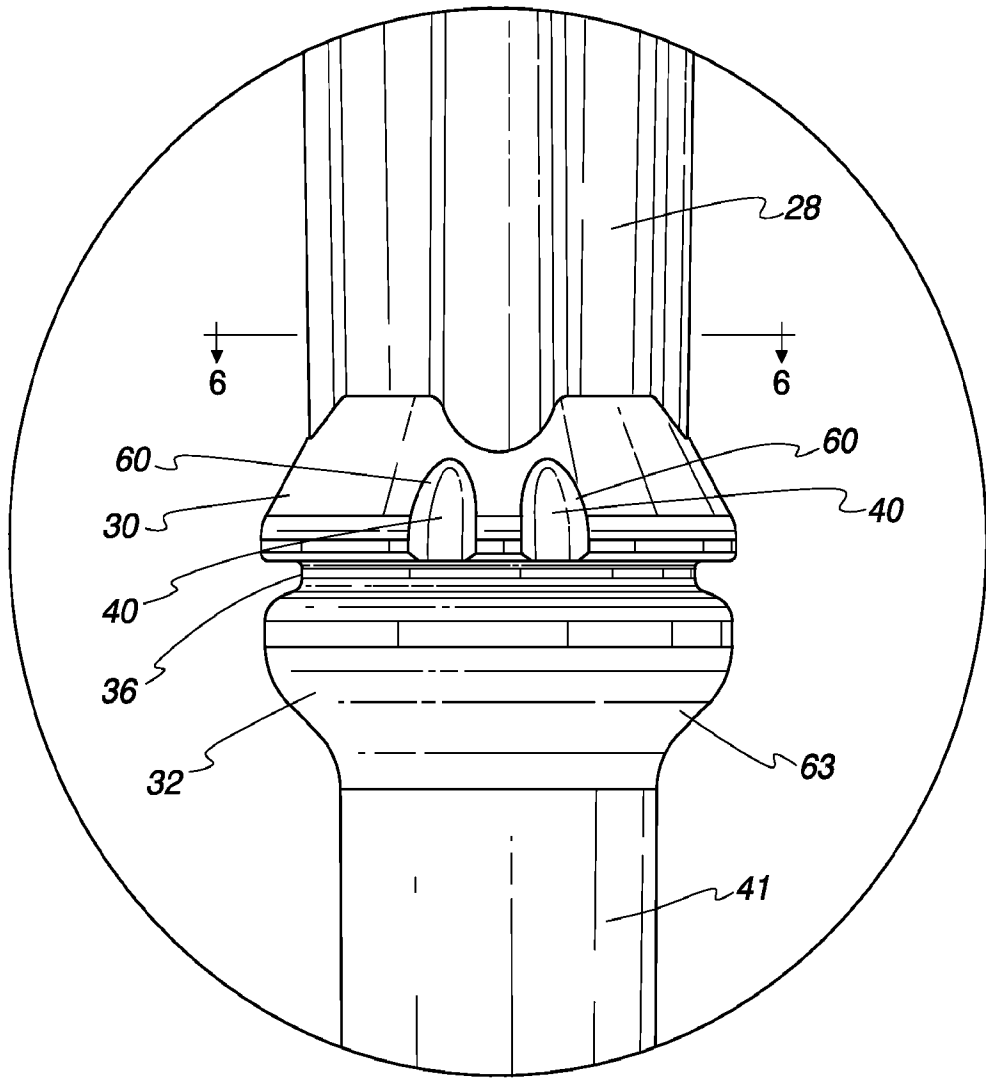
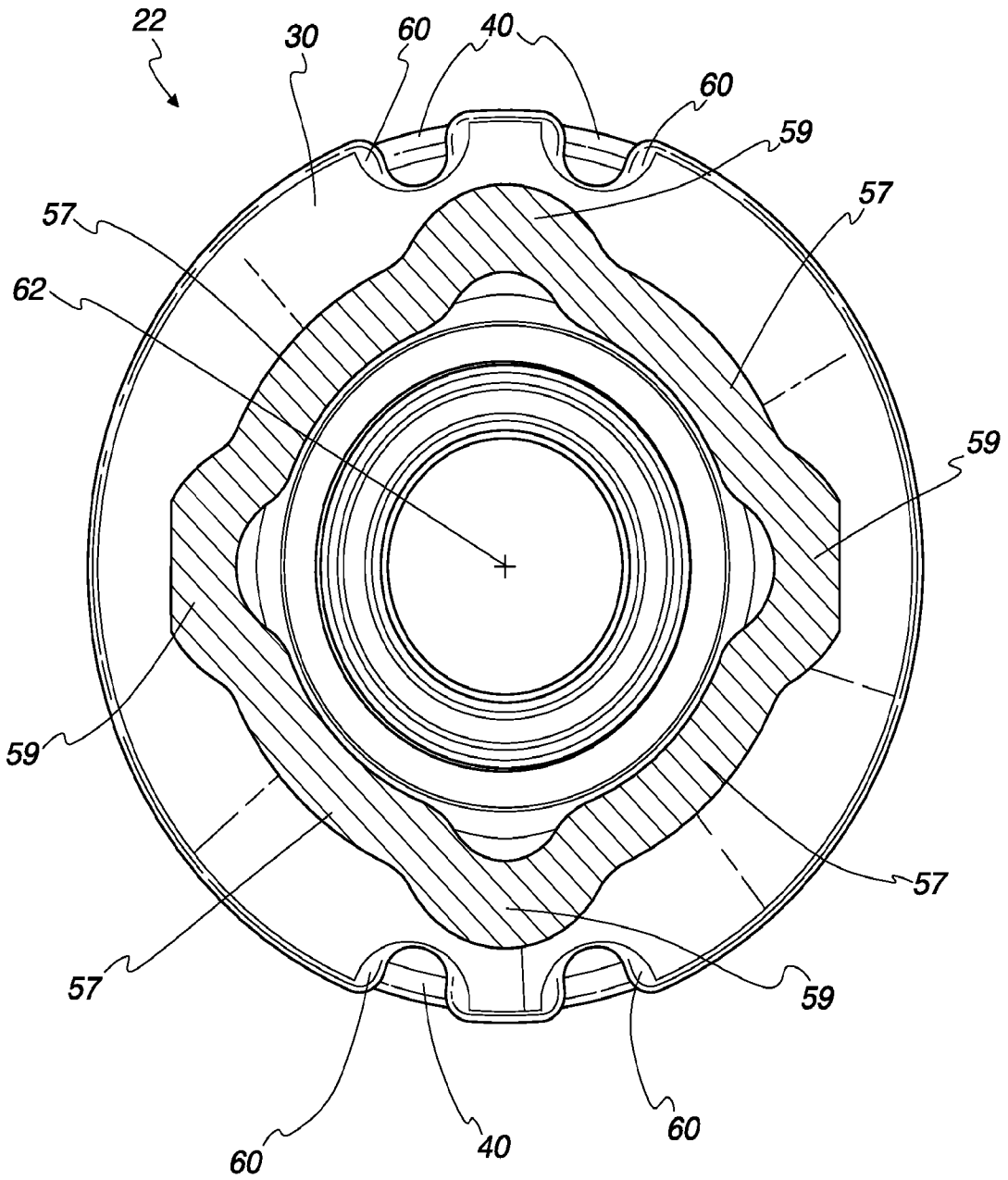

Fig. 6



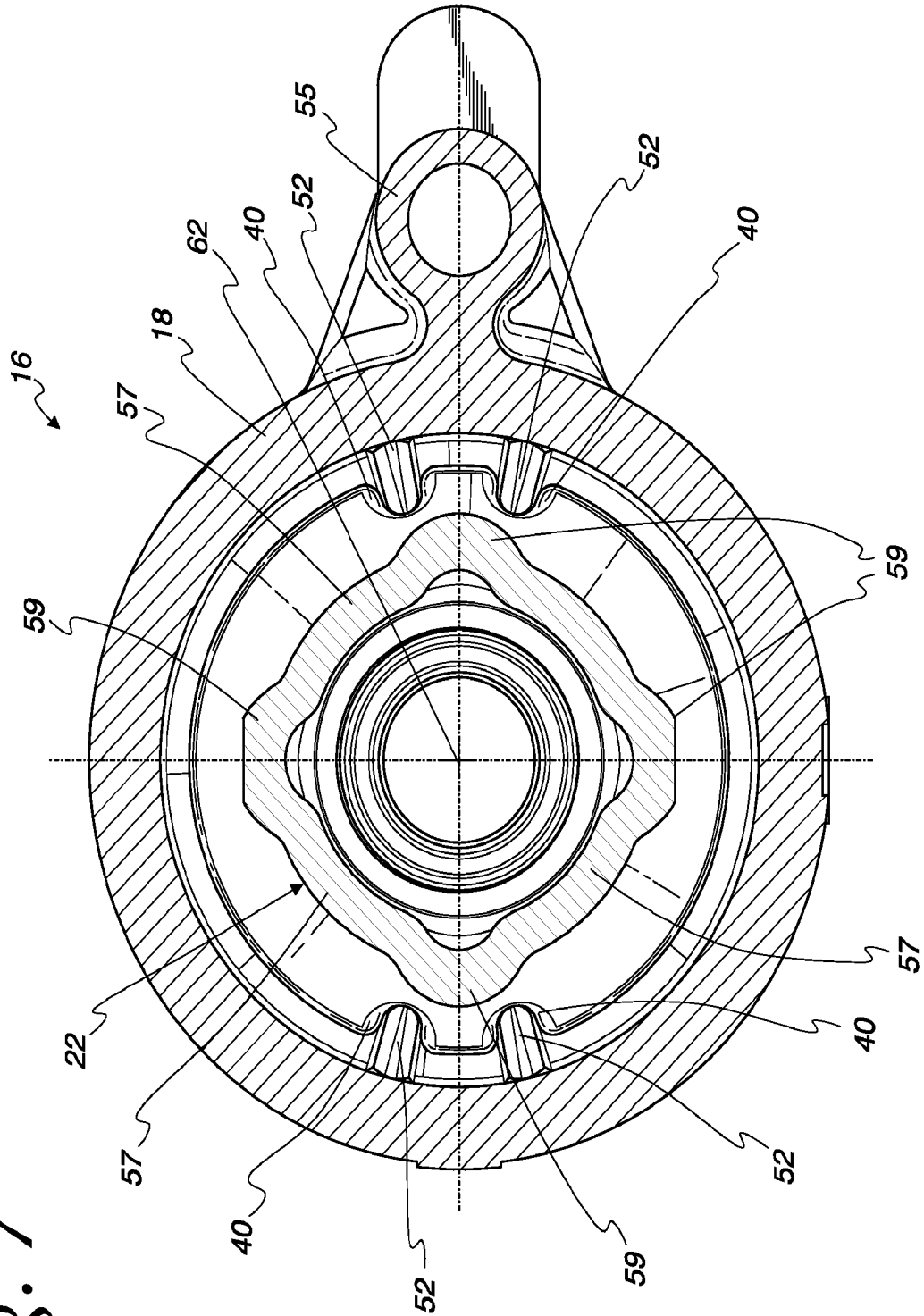

Fig. 7

INTERNATIONAL SEARCH REPORT

International application No
PCT/US2014/054681

A. CLASSIFICATION OF SUBJECT MATTER
INV. A01J5/08
ADD.

According to International Patent Classification (IPC) or to both national classification and IPC

B. FIELDS SEARCHED
Minimum documentation searched (classification system followed by classification symbols)
A01J

Documentation searched other than minimum documentation to the extent that such documents are included in the fields searched

Electronic data base consulted during the international search (name of data base and, where practicable, search terms used)
EPO-Internal, WPI Data

C. DOCUMENTS CONSIDERED TO BE RELEVANT

Category*	Citation of document, with indication, where appropriate, of the relevant passages	Relevant to claim No.
X	US 2011/126768 A1 (GRACE PATRICK P [GB] ET AL) 2 June 2011 (2011-06-02)	1,9,10
Y	figure 3	2-8, 11-19
A	----- US 2005/056225 A1 (AELVEBY NILS [SE] ET AL) 17 March 2005 (2005-03-17)	11
A	----- WO 01/45497 A1 (MILBRATH CONSTANCE J [US]; LARSON REED A [US]) 28 June 2001 (2001-06-28)	1
Y	----- GB 2 119 620 A (NU PULSE NEW ZEALAND LIMITED) 23 November 1983 (1983-11-23)	2-8, 11-19
	----- page 2, lines 36-44; figures 1,3	

Further documents are listed in the continuation of Box C.

See patent family annex.

* Special categories of cited documents :

- "A" document defining the general state of the art which is not considered to be of particular relevance
- "E" earlier application or patent but published on or after the international filing date
- "L" document which may throw doubts on priority claim(s) or which is cited to establish the publication date of another citation or other special reason (as specified)
- "O" document referring to an oral disclosure, use, exhibition or other means
- "P" document published prior to the international filing date but later than the priority date claimed

- "T" later document published after the international filing date or priority date and not in conflict with the application but cited to understand the principle or theory underlying the invention
- "X" document of particular relevance; the claimed invention cannot be considered novel or cannot be considered to involve an inventive step when the document is taken alone
- "Y" document of particular relevance; the claimed invention cannot be considered to involve an inventive step when the document is combined with one or more other such documents, such combination being obvious to a person skilled in the art
- "&" document member of the same patent family

Date of the actual completion of the international search

12 November 2014

Date of mailing of the international search report

19/11/2014

Name and mailing address of the ISA/

European Patent Office, P.B. 5818 Patentlaan 2
NL - 2280 HV Rijswijk
Tel. (+31-70) 340-2040,
Fax: (+31-70) 340-3016

Authorized officer

Nédélec, Morgan

INTERNATIONAL SEARCH REPORT

Information on patent family members

International application No

PCT/US2014/054681

Patent document cited in search report	Publication date	Patent family member(s)	Publication date	
US 2011126768	A1	02-06-2011	CN 102655738 A	05-09-2012
			CO 6511260 A2	31-08-2012
			NZ 599630 A	25-10-2013
			US 2011126768 A1	02-06-2011
			WO 2011068609 A2	09-06-2011

US 2005056225	A1	17-03-2005	NONE	

WO 0145497	A1	28-06-2001	AT 260548 T	15-03-2004
			AU 771236 B2	18-03-2004
			AU 2438601 A	03-07-2001
			CA 2394863 A1	28-06-2001
			DE 60008796 D1	08-04-2004
			DE 60008796 T2	13-01-2005
			DK 1239725 T3	19-04-2004
			EP 1239725 A1	18-09-2002
			ES 2217018 T3	01-11-2004
			JP 2003517315 A	27-05-2003
			MX PA02006188 A	05-12-2002
			US 6435132 B1	20-08-2002
			WO 0145497 A1	28-06-2001

GB 2119620	A	23-11-1983	AU 8411182 A	01-12-1983
			CA 1179289 A1	11-12-1984
			FR 2526628 A1	18-11-1983
			GB 2119620 A	23-11-1983
			NL 8201917 A	01-12-1983
			ZA 8203185 A	30-03-1983
