

[54] **COMBINED TEMPLATE AND SHIM FOR ADJUSTING THE CAMBER OF A MACPHERSON STRUT FOR VEHICLES**

[76] Inventor: **Robert J. Johnson**, 2562 Trevino Pl., Mesa, Ariz. 85205

[\*\*] Term: **14 Years**

[21] Appl. No.: **219,706**

[22] Filed: **Jul. 15, 1988**

[52] U.S. Cl. .... **D8/354; D10/64**

[58] Field of Search ..... **D8/349, 354, 399; 384/626; 188/201; 411/522, 537, 546, 539; 248/188.2; 403/409.1; D10/64; D19/39**

[56] **References Cited**

**U.S. PATENT DOCUMENTS**

1,492,561	5/1924	Gabriel .....	411/539
1,558,364	10/1925	Iverson .....	411/539 X
3,136,206	6/1964	Adams .....	411/546
4,809,421	3/1989	Justice .....	411/539 X

4,848,939 7/1989 Ludwig ..... 384/626

*Primary Examiner*—Wallace R. Burke  
*Assistant Examiner*—Freda S. Nunn  
*Attorney, Agent, or Firm*—Tod R. Nissle

[57] **CLAIM**

The ornamental design for a combined template and shim for adjusting camber of a MacPherson strut for vehicles, as shown and described.

**DESCRIPTION**

FIG. 1 is a front perspective view of a combined template and shim for adjusting the camber of a MacPherson strut for vehicles showing my new design; FIG. 2 is a top view thereof on an enlarged scale; FIG. 3 is a front elevational view thereof on an enlarged scale; and, FIG. 4 is a side elevational view thereof on an enlarged scale. The opposite views are identical to the views shown in FIGS. 2 to 4.

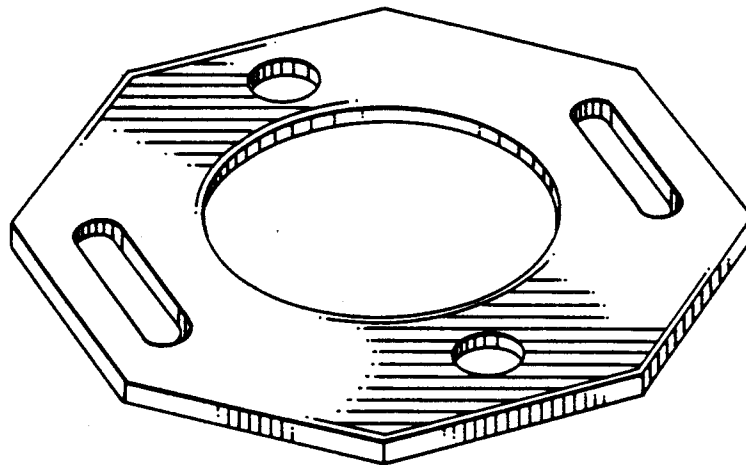

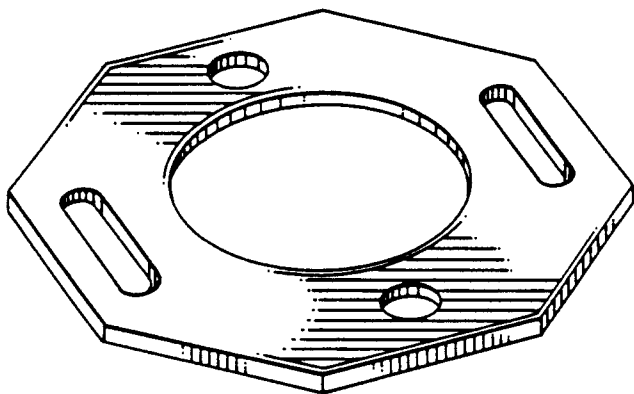

FIG. 1

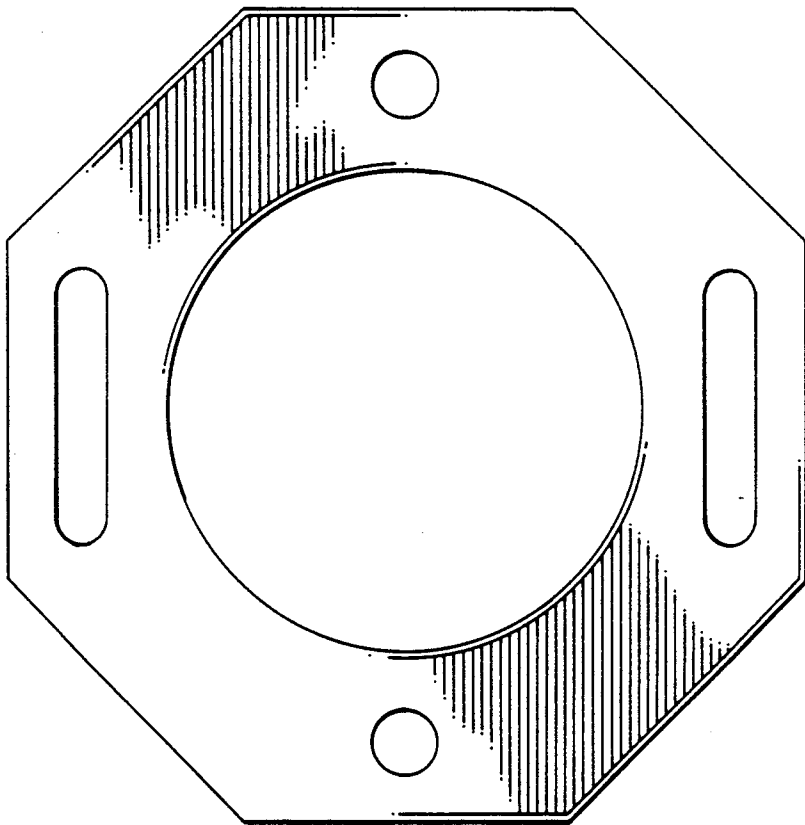

FIG. 2



FIG. 4



FIG. 3