

Aug. 17, 1965

A. WORSWICK

3,200,451

INGOT CASTING MACHINES

Filed May 11, 1962

5 Sheets-Sheet 1

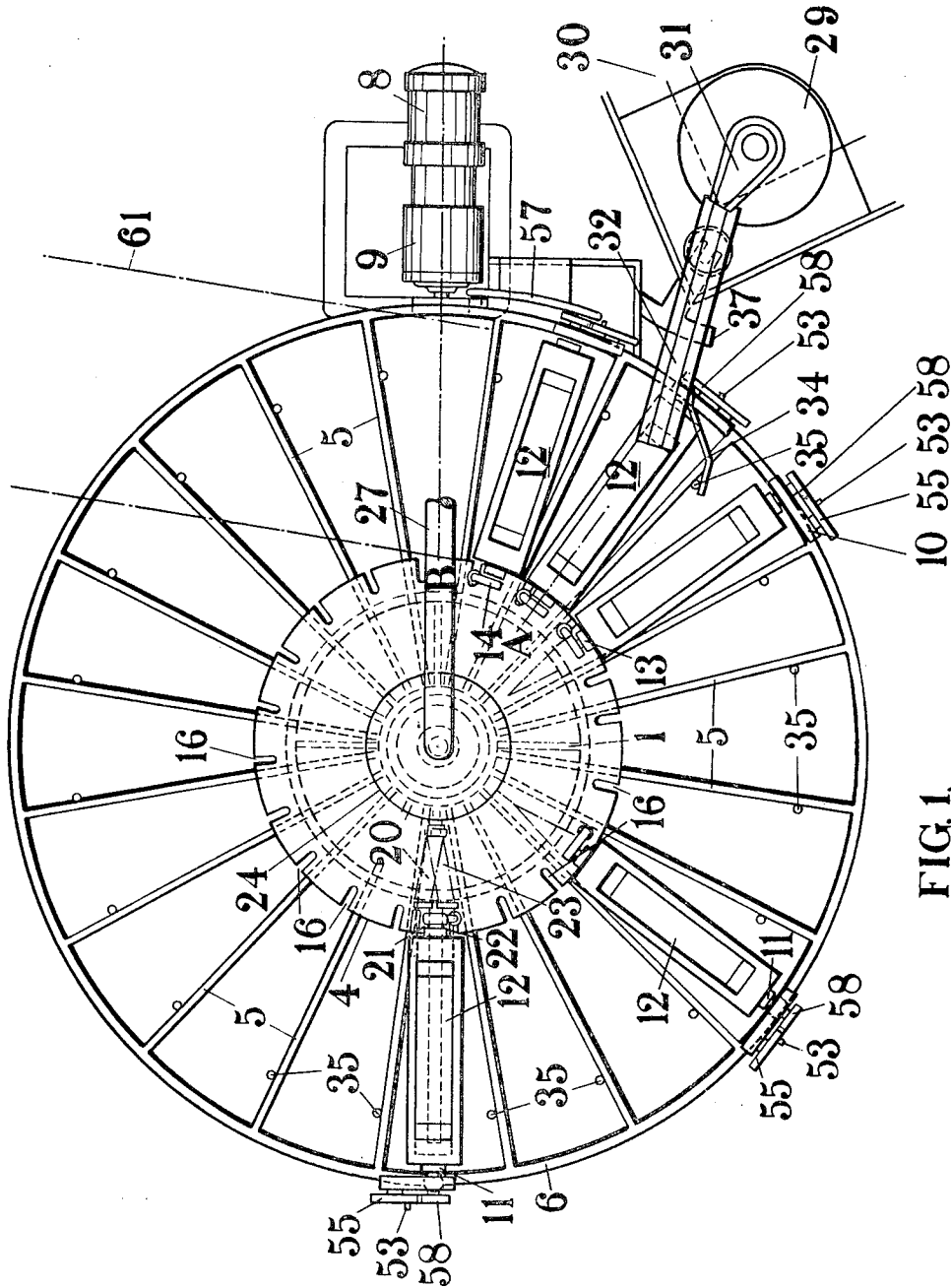

FIG. 1

Aug. 17, 1965

A. WORSWICK

3,200,451

INGOT CASTING MACHINES

Filed May 11, 1962

5 Sheets-Sheet 2

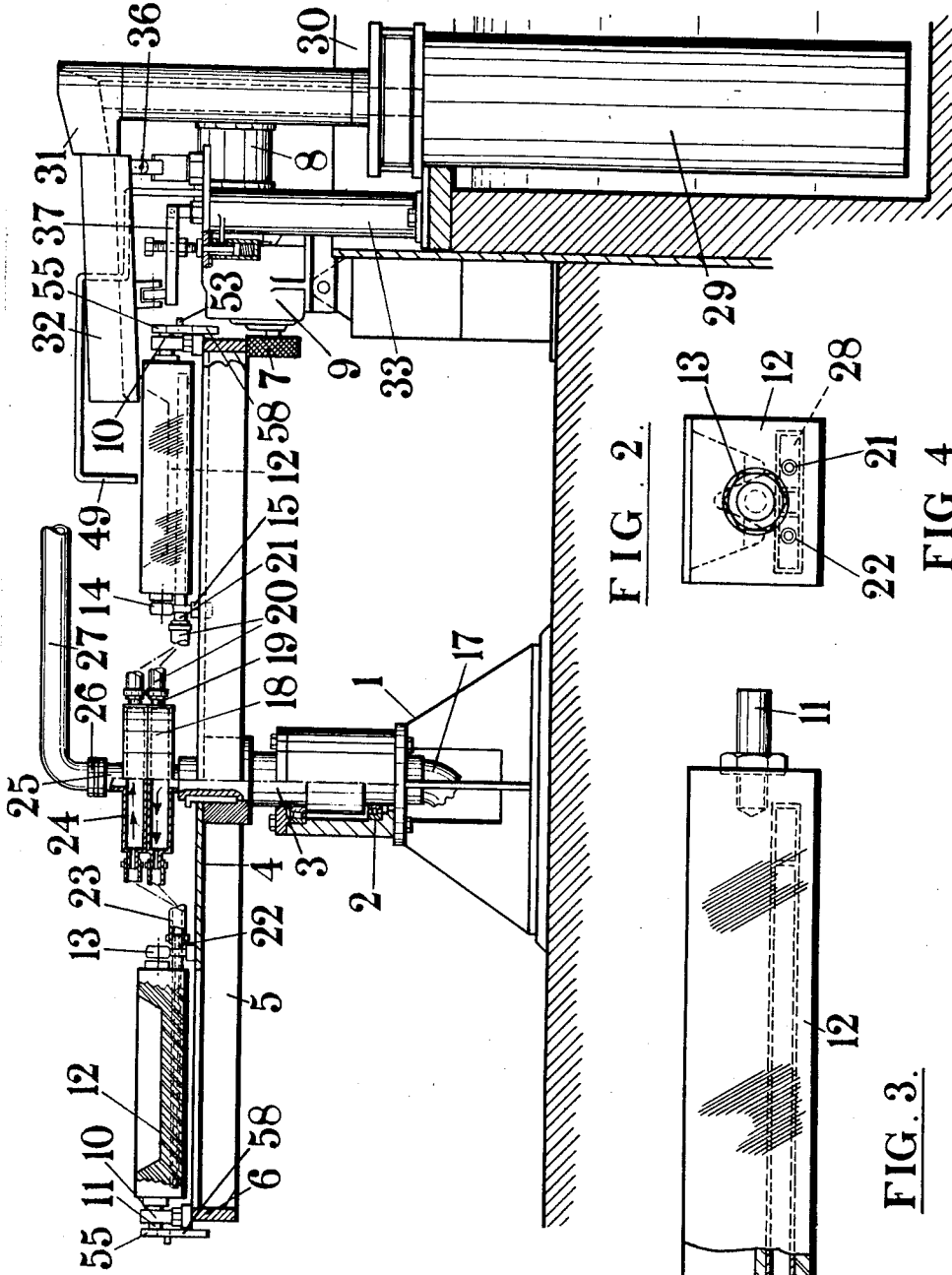

FIG. 2.

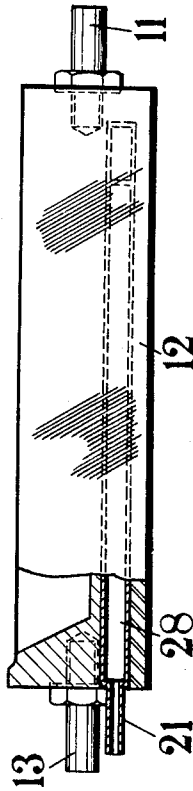

FIG. 3.

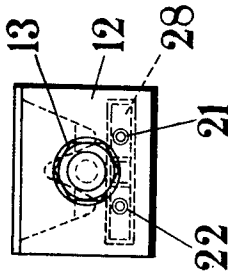

FIG. 4.

Aug. 17, 1965

A. WORSWICK  
INGOT CASTING MACHINES

3,200,451

Filed May 11, 1962

5 Sheets-Sheet 3

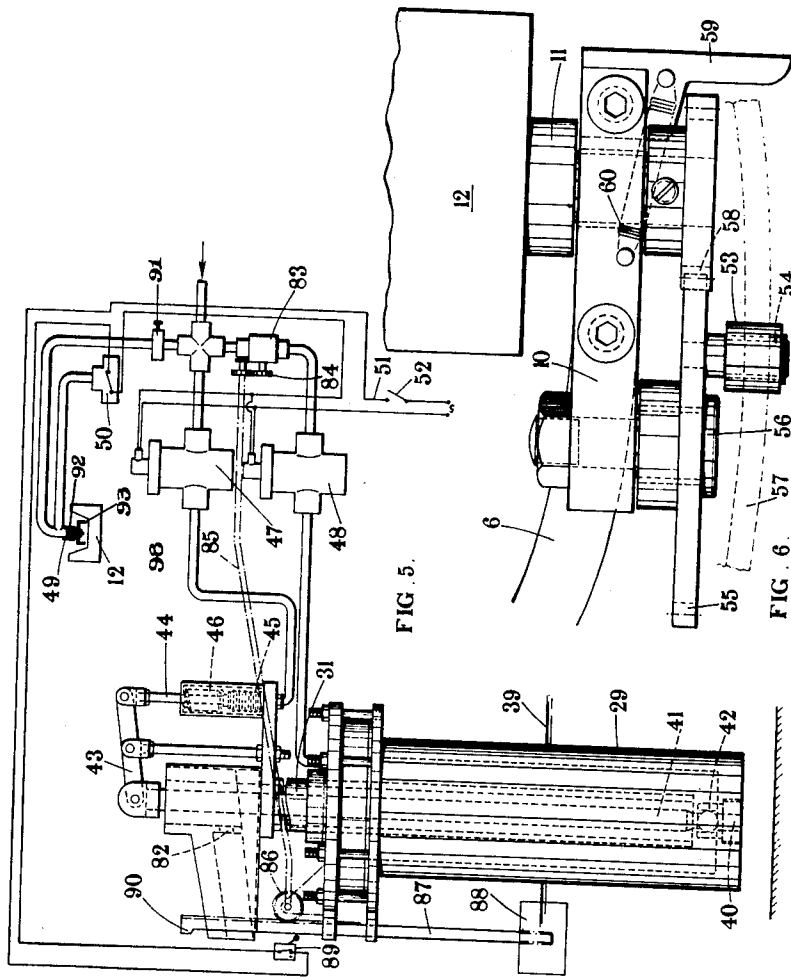

Aug. 17, 1965

A. WORSWICK  
INGOT CASTING MACHINES

3,200,451

Filed May 11, 1962

5 Sheets-Sheet 4

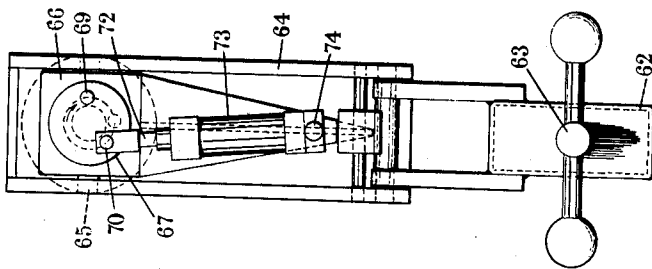

FIG. 9.

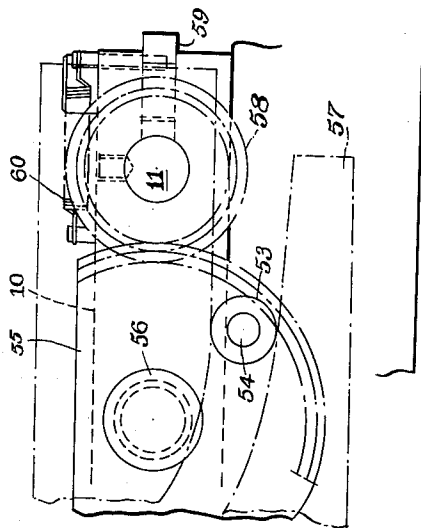

FIG. 7.

Aug. 17, 1965

A. WORSWICK  
INGOT CASTING MACHINES

3,200,451

Filed May 11, 1962

5 Sheets-Sheet 5

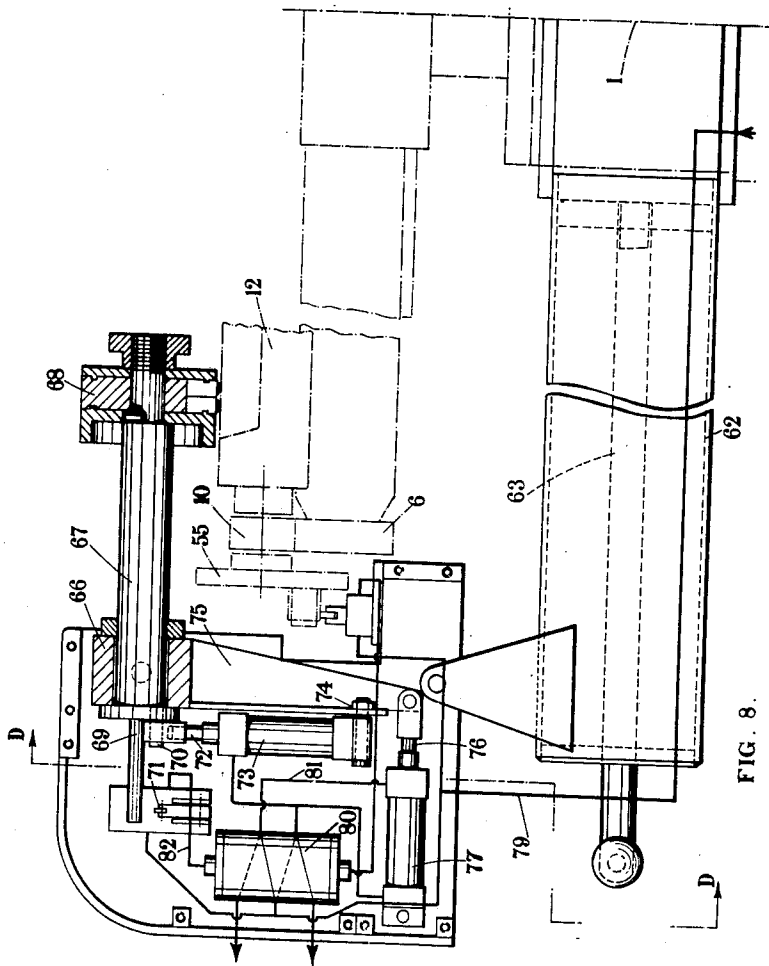

FIG. 8.

1

3,200,451

## INGOT CASTING MACHINES

Alan Worswick, Blackburn, England, assignor to Alan Worswick (Engineering) Limited, Blackburn, England, a company of Great Britain

Filed May 11, 1962, Ser. No. 194,032

5 Claims. (Cl. 22-63)

This invention relates to ingot casting machines.

Normally, ingot moulds are mounted on conveyor chains passing over suitable sprockets or wheels, cooling being effected by spraying the undersides of the moulds with water. Less than half of the moulds are in use at any time, since those on the return strand and on one of the sprockets or wheels are empty, and clean water has to be used to avoid staining the ingots.

In the machine according to the invention, the moulds are arranged radially about an axis around which they are rotated, means being provided for ejecting each ingot at a position immediately before that at which pouring is effected and each mould incorporating water cooling means.

With this arrangement all the moulds but one may be in use at all times, and more efficient cooling is obtainable while it is not necessary to use clean water as the water does not come into contact with the ingot. The total number of moulds needed may be less than one quarter of the usual number.

The mould assembly may be rotated continuously or intermittently, means being provided for carrying out the operations of feeding the molten metal, as by a pump, tilting launder or ladle, removing dross from the top of the ingot, stamping with identifying marks and ejection. The ejected ingots may be accurately placed for automatic stacking.

The moulds may be carried by a central shaft running in roller bearings away from the source of heat. Water may be supplied through a pipe passing through the central shaft, with flexible tubes to the moulds, and flexible outlet tubes from the moulds may return the water to a header tank above the shaft.

The moulds may be pivotally mounted at their ends and may be inverted by a suitable gearing for ejecting the ingots.

Referring to the accompanying drawings:

FIGURE 1 is a plan view of a casting machine in accordance with the invention.

FIGURE 2 is a section on the line A-B-C of FIGURE 1.

FIGURE 3 shows an ingot mould partly in horizontal section and partly in elevation.

FIGURE 4 shows a mould in end elevation.

FIGURE 5 shows a molten metal pump and its operating means.

FIGURE 6 shows in plan a means for inverting the moulds.

FIGURE 7 is an elevation of the means shown in FIGURE 6.

FIGURE 8 shows a means for marking ingots.

FIGURE 9 is a section on the line D-D of FIGURE 8.

A housing 1 contains bearings 2 for a vertical shaft 3 supporting a turntable comprising a central disc 4, radial ribs 5 and a rim 6. The drive is by a friction wheel 7 to the lower edge of the rim, the wheel 7 being driven by a motor 8 through a variable speed reduction gear 9. Around the upper edge of the rim 6 there are mounted trunnion bearing blocks 10 carrying trunnions 11 at the outer ends of ingot moulds 12. At the inner ends of the moulds 12 there are trunnions 13 mounted in trunnion bearings 14 which are secured by nuts 15 in slots 16 in the disc 4.

2

The shaft 3 is hollow and at its lower end it is connected through a swivel joint to a pipe 17 for supplying cooling water. Its upper end projects above the disc 4 into a header tank 18 having radial outlets 19 connected by flexible pipes 20 to water inlets 21 on the moulds 12. Water outlets 22 on the moulds 12 are connected by flexible pipes 23 to a header tank 24 mounted above the tank 18 and having an outlet 25 connected by a swivel joint 26 to a stationary pipe 27. As shown in FIGURES 3 and 4 each mould 12 has embedded in its lower part a steel tube 28 through which the cooling water flows from the inlet 21 to the outlet 22, whereby the water is prevented from coming into contact with molten metal if the mould should crack.

The moulds 12 are charged with metal by a pump 29 immersed in molten metal in a furnace 30. The delivery pipe 31 from the pump 29 feeds the metal through an orifice 32 into a launder 32 which is pivotally mounted on a post 33. An arm 34 projecting from the launder 32 is engaged by pegs 35 on the ribs 5, and is turned to keep the outlet end of the launder 32 above the corresponding mould 12 while it is being filled. Then the arm 34 slips off the peg 35 as the latter continues to move, and the launder 32 is turned back by a spring (not shown) until the arm 34 strikes the next peg 35. The launder 32 is supported at the inlet end on a pivot 36, and its outlet end is supported through a roller by a roller path 37 which is adjustable by means of a nut 38.

The arrangement of the pump 29 is shown in FIGURE 5. The pump is immersed in molten metal, to the level of the line 39. An opening 40 at the bottom of the pump casing admits metal to the interior of the casing, and has a valve seat 42 which can be closed by a valve member 41 extending through the outlet pipe 31 and pivoted to one end of a lever 43 above the outlet. The lever 43 is pivoted at its other end to a rod 44 attached to a bellows 45 which is loaded by a spring 46. The interior of the bellows 45 is connected through a pipe 98 and an electrically controlled valve 47 to a compressed air supply. The air supply is connected also through a reducing valve 83 and an electrically controlled valve 48 to the interior of the pump 29 above the metal level. The reducing valve 83 requires to be set to supply sufficient pressure to the pump to raise the metal in the outlet pipe 31 to a set height above the orifice 32 to give the desired rate of flow, the pressure required being dependent upon the level 39 of the metal in the bath. For this purpose the reducing valve 83 is adjusted through gears 84 by a flexible shaft 85 which is rotated by a gear 86 turned by a rack 87, the lower end of which carries a float 88 which rises or falls with the level of the metal in the bath. The ratio of the gears 84 may be altered to suit the density of the metal being used.

When the metal level falls to 1 inch above the bottom of the outlet pipe 31, a limit switch 89 is operated by a cam 90 on the rack 87 to open the electrical circuit to the valves 47 and 48, which then close and cut off the supply of air to the bellows 45 and pump 29 and so prevent further delivery of metal.

The air supply is further connected through a needle valve 91 to a nozzle 49 carried by the launder 32 above the mould 12. At the outlet of the nozzle 49 there is a valve 92 which is lifted by a float 93 when the mould is filled to the desired height. From the nozzle 49 an air pipe leads to a pressure switch 50 connected in the electric supply line 51 to the valves 47, 48. The switch 50 is normally closed and on a switch 52 in the line 51 being closed, the valves 47, 48 are opened whereby the valve 41 is closed (due to the bellows 45 being extended against the spring 46), and air is admitted to the pump 29 to expel metal, the molten metal forming an air seal between the moving valve rod 41 and outlet pipe 31. When the

mould 12 is filled to the desired level, the back pressure in the nozzle 49 opens the pressure switch 50 and energises the valves 47, 48 and so stops the flow of metal. The roller path 37 is supported by a piston 94 in a cylinder 95, and is initially raised by a spring 96 so that the float 93 is clear of the mould. The space in the cylinder 95 above the piston 94 is connected by a pipe 97 to the air pipe 98 leading from the valve 47 to the bellows 45, so that when air is supplied to operate the metal pump, the piston 94 is depressed and the roller track 37 is lowered, together with the launder 32, and the float 93 is lowered to the correct height in relation to the mould, when the pressure switch 50 is operated, the air supply is cut off by the valve 47 and the spring 96 lifts the roller track 37 until the float 93 is clear of the mould. The switch 52 is closed by a cam arrangement on the turntable when a mould comes into position to be filled, and is opened again when the mould passes from beneath the launder 32.

Having been charged with molten metal at the position A in FIGURE 1, a mould is carried round on the turntable while the ingot is being cooled, until it reaches the position B. At this point, as shown in FIGURES 6 and 7, a roller 53 on a pin 54 fixed in a gear wheel 55 on a shaft 56 mounted in the bearing block 10 engages a fixed cam plate 57, whereby the gear wheel 55 is rotated and turns a gear wheel 58 meshing with it and fixed on the end of the trunnion 11. The cam plate 57 also engages a catch 59 pivotally mounted on the block 10 and loaded by a spring 60, to withdraw it from a slot in the hub of the gear wheel 58. The cam plate 57 is shaped to turn the mould through 180° so as to allow the ingot to drop on to a conveyor 61 beneath the turntable, and then to turn the mould back ready to be recharged.

It will be understood that a hydraulic system could equally well be used instead of a pneumatic system.

FIGURES 8 and 9 show an arrangement for marking the ingots. This is supported by an arm 62 which is clamped onto the circular part of the housing 1 enclosing the bearings 2, by means of a screw 63, in such a position that the ingots are marked where the metal has just solidified so that minimum pressure is required. The arm 62 supports a frame 64 in which there is pivoted at 65 a block 66 in which is mounted a shaft 67. On the outer end of the shaft 67, above the mould 12, there is a drum 68 carrying type for marking the ingot, and at the end which is mounted in the block 66 there are projecting eccentric pins 69, 70. The pin 69 can operate a fluid valve 71 as the shaft 67 rotates, and the pin 70 is connected to the piston rod 72 of a fluid jack 73 which is pivotally mounted on the frame 64 at 74. An arm 75 extending downwards from the block 66 is connected to the piston rod 76 of a fluid jack 77 mounted on the frame 64. A fluid valve 78 is placed so as to be actuated by the roller 53 mounted on the gear wheel 55 as a mould 12 is coming under the drum 68. This admits fluid from a supply line 79 to a change-over valve 80 whereby fluid from the line 79 is admitted to the jack 77 through the line 81 to cause the drum 68 to be lowered onto the ingot. On making contact with the ingot, the drum 68 is rotated by the movement of the ingot while the latter is being marked until the pin 69 operates the valve 71 which admits fluid through the line 82 to the other end of the change-over valve 80, which then supplies fluid through the line 83 to the jack 77 to raise the drum 68, and to the jack 73 to pull down the pin 70 and rotate the drum 68 back to its initial position.

Instead of using the nozzle 49 and switch 50, the circuit to the valves 47, 48 may be broken by a probe which, when contacted by the molten metal in the mould will complete an electrical circuit to the coil of a normally closed relay, or by a timing clock started by a metal completing a circuit across two probes at the delivery orifice of the pump, which, on completion of the

set time will open a contact on the line feeding the two solenoids.

What is claimed is:

1. An ingot casting machine comprising a base, a vertical shaft rotatably mounted on said base, a horizontal turntable carried by said shaft, means to rotate said turntable, a plurality of radially disposed ingot molds pivotally mounted on said turntable for movement from an upright mold filling position to an inverted ingot discharge position, means including a steel tube embedded in a wall of each mold for circulating a cooling medium, means for successively filling said molds with molten metal during continuous rotation of said table and comprising a launder pivotally mounted for movement about a vertical axis and with the discharge end of said launder disposed above the path of movement of said molds, means for feeding molten metal to said launder including a pump having a portion thereof immersed in a bath of molten metal, a power operated valve for controlling flow of metal from said bath to said pump, and means for preventing operation of said pump when the metal in said bath reaches a predetermined low level, an upwardly projecting pin on said turntable adjacent each mold, an arm projecting from said launder in the path of movement of said pin, means for biasing said launder to an initial mold filling position, whereby upon movement of said turntable a pin will engage said arm and move said launder and maintain the discharge end of said launder above a mold until filling thereof is completed whereupon said arm will disengage from the pin and permit said launder to return to initial position, automatic means for controlling the feed of metal to said launder to fill each mold to the desired depth, said automatic means including solenoid valves for controlling the operation of said pump and said valve, a reducing valve controlled in accordance with the level of metal in said bath to in turn control the operating pressure of said pump, a normally open switch in series with a normally closed switch for controlling the operation of said solenoid valves, cam means on said turntable for closing said normally open switch when a mold is in position to be filled, and means projecting into the mold being filled and connected to said normally closed switch to open the same when the metal in the mold being filled reaches a predetermined level, and means operable in response to rotation of said turntable for successively inverting said molds to discharge ingots therefrom and for returning said molds to filling position.

2. An ingot casting machine as defined in claim 1, in which the means projecting into the mold being filled is mounted on said launder and means to raise and lower said launder as the same moves from a filled mold to an empty mold.

3. An ingot casting machine as defined in claim 1, in which said means to successively invert said molds and return the same to filling position comprises a cam fixed with respect to said turntable, an inverting gear fixed to each mold, a second gear rotatably mounted on said turntable adjacent each mold and meshing with said inverting gear and a cam follower on said second gear, whereby upon rotation of said turntable said cam follower will engage said cam to rotate said gears and invert said mold and thereafter return said mold to filling position.

4. An ingot casting machine as defined in claim 1, in which a latch is provided for retaining each mold in filling position and means on said latch engaging said cam to release said latch and permit movement of said mold to inverted position.

5. An ingot casting machine as defined in claim 1, in which means is provided for marking each ingot prior to discharge from the mold, said marking means comprising a bar overhanging said molds at the outer end, means mounting said bar at the inner end for rotation and for pivotal vertical swinging movement about a hori-

5

zontal axis, a marking die fixed to the outer end of said bar and rotatable therewith, means to pivot said bar downwardly to engage said die with an ingot in a mold whereby rotation of said turntable will cause rotation of said die and bar to mark the ingot, control means operable in response to a predetermined rotation of said bar to energize means to pivot said bar upwardly and move said die away from the ingot and means to rotate said bar and die to original position.

References Cited by the Examiner

UNITED STATES PATENTS

1,156,446 10/15 Taylor et al. ----- 22-63  
 1,695,855 12/28 Moore et al. ----- 22-26 XR

6

1,703,708 2/29 Candler ----- 22-10  
 1,816,059 7/31 Smith ----- 22-77  
 1,966,596 7/34 Pierce ----- 22-63  
 2,012,189 8/35 Fritz ----- 22-77  
 2,221,711 11/40 Kurkjian ----- 18-2  
 2,461,281 2/49 Jackson et al.  
 2,672,661 3/54 Lutz ----- 22-63  
 2,806,264 9/57 Keating ----- 22-77 XR  
 2,982,534 5/61 Meffert ----- 22-79 XR  
 3,050,794 8/62 Holz ----- 22-79

J. SPENCER OVERHOLSER, *Primary Examiner.*

ROBERT A. WHITE, MICHAEL V. BRINDISI, *Examiners.*