



## INTERNATIONAL APPLICATION PUBLISHED UNDER THE PATENT COOPERATION TREATY (PCT)

<p>(51) International Patent Classification<sup>6</sup> : <b>A61C 3/00</b></p>	<p><b>A1</b></p>	<p>(11) International Publication Number: <b>WO 99/02101</b></p> <p>(43) International Publication Date: 21 January 1999 (21.01.99)</p>
<p>(21) International Application Number: PCT/US97/11849</p> <p>(22) International Filing Date: 7 July 1997 (07.07.97)</p> <p>(71)(72) Applicant and Inventor: SVANBERG, Gunnar, K. [US/US]; Apartment D23, 5400 N.W. 39th Avenue, Gainesville, FL 32606 (US).</p> <p>(74) Agents: SALIWANCHIK, David, R. et al.; Saliwanchik, Lloyd &amp; Saliwanchik, Suite A-1, 2421 N.W. 41st Street, Gainesville, FL 32606-6669 (US).</p>		<p>(81) Designated States: AL, AU, BA, BB, BG, BR, CA, CN, CU, CZ, EE, GE, HU, IL, IS, JP, KP, KR, LC, LK, LR, LT, LV, MG, MK, MN, MX, NO, NZ, PL, RO, SG, SI, SK, SL, TR, TT, UA, UG, UZ, VN, YU, ARIPO patent (GH, KE, LS, MW, SD, SZ, UG, ZW), Eurasian patent (AM, AZ, BY, KG, KZ, MD, RU, TJ, TM), European patent (AT, BE, CH, DE, DK, ES, FI, FR, GB, GR, IE, IT, LU, MC, NL, PT, SE), OAPI patent (BF, BJ, CF, CG, CI, CM, GA, GN, ML, MR, NE, SN, TD, TG).</p> <p><b>Published</b> <i>With international search report.</i></p>
<p>(54) Title: NOVEL DENTAL CURETTES</p>		
		
<p>(57) Abstract</p> <p>The subject invention pertains to unique dental curettes made with powder injection molded compounds. These curettes have excellent properties including uniformity and precision. The curettes can be readily prepared in a variety of different shapes. The curettes can comprise a bar code or other suitable reference means to facilitate placement in an automated curette sharpener.</p>		

**FOR THE PURPOSES OF INFORMATION ONLY**

Codes used to identify States party to the PCT on the front pages of pamphlets publishing international applications under the PCT.

AL	Albania	ES	Spain	LS	Lesotho	SI	Slovenia
AM	Armenia	FI	Finland	LT	Lithuania	SK	Slovakia
AT	Austria	FR	France	LU	Luxembourg	SN	Senegal
AU	Australia	GA	Gabon	LV	Latvia	SZ	Swaziland
AZ	Azerbaijan	GB	United Kingdom	MC	Monaco	TD	Chad
BA	Bosnia and Herzegovina	GE	Georgia	MD	Republic of Moldova	TG	Togo
BB	Barbados	GH	Ghana	MG	Madagascar	TJ	Tajikistan
BE	Belgium	GN	Guinea	MK	The former Yugoslav Republic of Macedonia	TM	Turkmenistan
BF	Burkina Faso	GR	Greece			TR	Turkey
BG	Bulgaria	HU	Hungary	ML	Mali	TT	Trinidad and Tobago
BJ	Benin	IE	Ireland	MN	Mongolia	UA	Ukraine
BR	Brazil	IL	Israel	MR	Mauritania	UG	Uganda
BY	Belarus	IS	Iceland	MW	Malawi	US	United States of America
CA	Canada	IT	Italy	MX	Mexico	UZ	Uzbekistan
CF	Central African Republic	JP	Japan	NE	Niger	VN	Viet Nam
CG	Congo	KE	Kenya	NL	Netherlands	YU	Yugoslavia
CH	Switzerland	KG	Kyrgyzstan	NO	Norway	ZW	Zimbabwe
CI	Côte d'Ivoire	KP	Democratic People's Republic of Korea	NZ	New Zealand		
CM	Cameroon			PL	Poland		
CN	China	KR	Republic of Korea	PT	Portugal		
CU	Cuba	KZ	Kazakstan	RO	Romania		
CZ	Czech Republic	LC	Saint Lucia	RU	Russian Federation		
DE	Germany	LI	Liechtenstein	SD	Sudan		
DK	Denmark	LK	Sri Lanka	SE	Sweden		
EE	Estonia	LR	Liberia	SG	Singapore		

DESCRIPTIONNOVEL DENTAL CURETTES5 Cross-Reference to Related Applications

This application is a continuation-in-part of co-pending application Serial No. 08/556,047, filed November 13, 1995; which is a continuation-in-part of application Serial No. 08/320,746 filed January October 11, 1994, now abandoned.

10 Field of the Invention

The present invention relates to dental tools and more particularly to novel dental currettes having unique and advantageous properties.

Background of the Invention

15 Scaling and root planing for the removal of calculus and contaminated root cementum are essential procedures in the treatment of periodontal diseases. For this purpose, dental currettes are used for orthogonal cutting of the root surfaces, a process that removes calculus and thin chips of contaminated root cementum.

20 These procedures dull the edge of the currettes, which for proper cutting action has to be sharpened at frequent intervals. Up to now, such sharpening has been done as a freehand procedure with or without guide plates, resulting in edges of inferior sharpness, incorrect edge angles, and serious aberrations from the ideal shape of the cutting blade. Although machines have been proposed to help in the process of sharpening currettes, until now, no machine could accurately and efficiently produce a sharp cutting edge on  
25 any of a series of currettes with different rake angles. See, for example, U.S. Patent Nos. 1,350,951; 2,114,757; 2,578,309; 4,535,570; and 2,380,988.

A variety of dental currettes of different shapes are available on the market, but there is no one single set of currettes that in a systematic and logical way guides the operator in the selection of instruments needed for optimal efficiency in the different  
30 areas of the oral cavity. See, for example, U.S. Patent Nos. 1,605,320; 1,495,115; 1,138,355; and 2,366,671.

Most curettes on the market are double-ended, i.e., comprise a longitudinal handle with a cutting blade at the distal end of a shank, which is secured to each end of the handle. The handles usually are made out of metal tubing, the surface of which is processed to give different patterns of groves and ridges to increase the friction when holding the curettes during the scaling and root planing procedures.

The shanks are made from slightly conical metal rods, which are bent into various shapes for curettes of different rake angles. As is apparent, bending the shank to provide the desired rake angle is a labor-intensive procedure. It requires the use of a relatively soft metal that has to be tempered or otherwise treated for giving the shank with its cutting blade reasonable hardness. Fairly crude templates are used during the bending of the shanks, which makes the process contingent on the utmost skill of the worker for achieving a reasonable precision of the curette. Despite all these efforts, the accuracy and precision of today's commercially available curettes are not very good, and they get dull after a very short time of scaling and root planing.

After the shanks are bent into the desired rake angle, they are secured to the handle of the curette by crimping, soldering, or other means. The distal end of the shank is ground to form the cutting blade, again a procedure that requires a skilled worker. All these difficulties in manufacturing dental curettes and the shortcomings of the final product made us look for alternative processes and materials.

20

#### Brief Summary of the Invention

The subject invention pertains to dental curettes and a sharpening machine having design features that make them integral parts of a dental curette and sharpening machine system that allows both professional and non-professional personnel to sharpen dental curettes with the utmost precision.

25

In one aspect, the system of the subject invention provides a fully guided and automatic procedure for sharpening curettes. In one embodiment, which utilizes a central processing unit (CPU) with software stored in an erasable programmable read-only memory (EPROM), the subject invention pertains to an automatic curette sharpening machine that is able to automatically, accurately, and quickly sharpen the cutting edge of any one of a series of dental curettes having different rake angles.

30

A further aspect of the present invention pertains to novel materials and technologies for manufacturing dental curettes of extremely high accuracy and precision unavailable in the prior art. One aspect of this embodiment of the present invention provides a method for fabricating dental curettes by using powder injection molding (PIM) technology. This method of the subject invention enables high-volume production of geometrically complex instruments having great accuracy and precision.

It is yet another aspect of the present invention to incorporate computer-assisted design (CAD)/computer-assisted manufacturing (CAM) in the protocol for fabricating dental curettes, using CAD for designing the curettes and CAM for fabrication of the molds for subsequent manufacturing of the curette shanks with their cutting blades.

It is a further object of the present invention to coat at least the edge portion of a curette's cutting blade with a compound of extreme hardness, which makes it possible to establish, and if so needed restore, cutting edges of the utmost sharpness and durability.

It is another object of the present invention to determine the optimal thickness and configuration of a coating compound of extreme hardness, covering at least the edge portion of a curette's cutting blade, so that sharpening of the cutting blade produces an edge of long-lasting sharpness although most of the grinding is on the substantially softer core material of the cutting blade.

It is also the object of the present invention to coat at least the edge portion of the curette's cutting blade with a compound of extreme hardness for producing a cutting edge of long-lasting sharpness, which will allow the selection of a compound for the core portion of the shank with its cutting blade to be based on its resistance to breakage during the scaling and root planing procedure.

It is thus an object of the present invention to provide a compound for the core portion of the shank with its cutting blade that gives optimal resistance to breakage.

It is also the object of the present invention to mold a compound of extreme hardness into the edge portion of the curette's cutting blade so that sharpening of cutting blades is not needed.

The curettes of the subject invention have a unique molecular structure resulting from the production of the curettes by powder injection molding. The instruments are

comprised of powder particles of a size in the low micron range that, through heat treatment in various gaseous environments, have been sintered to form solid and strong bodies. The molecular structure of these currettes is distinct from the molecular structure of currettes made using other techniques such as forging or investment cast. The currettes produced according to the methods of the subject invention have highly desirable characteristics as described herein. The currettes of the subject invention also differ from other currettes because of the presence of minute amounts of binding material and slightly increased interstitial space.

The foregoing features, advantages, and benefits of the invention, along with additional ones, will be seen in the ensuing description and claims, which should be considered in conjunction with the accompanying drawings. The drawings disclose selected embodiments of the invention.

#### Brief Description of the Drawings

**Figure 1** is a side view of a double-ended currette.

**Figure 2A** is an enlarged transverse view taken in the direction of the arrows 2A--2A in Figure 1B. Note the layer of hard compound coating the cutting blade.

**Figure 2B** is a further enlargement of a side edge in Figure 2A.

**Figure 2C** shows a rotary sharpening element in contact with a side edge of the cutting blade during the sharpening procedure.

**Figure 2D** shows the enlarged transverse view of a cutting blade as in Figure 2A after some sharpening of the edge. Note the removal of the hard coating metal on the lateral base surface.

**Figure 2E** is a further enlargement of the sharpened side edge as seen in Figure 2D.

### Detailed Disclosure of the Invention

The following description of the dental curette manufacturing system is only one of many possible configurations contemplated according to the subject invention. This description of preferred embodiments serves to exemplify the underlying principles of the invention.

In one embodiment, the present invention involves CAD design of dental curettes followed by CAM fabrications of molds for manufacturing dental curettes using the powder injection molding (PIM) technology described herein. In one embodiment of the subject invention, the edge of the cutting blades can be given long-lasting sharpness by either coating the edge portion with a compound of extreme hardness, or molding a compound of extreme hardness into the edge portion of the cutting blades. The following description exemplifies one of many possible protocols for the implementation of these concepts.

1. Computer-aided design/computer-aided manufacturing (CAD/CAM). The use of CAD greatly facilitates curette design and the manufacturing of molds, which are used in the PIM process for fabricating the shanks with their cutting blade. The use of CAD/CAM in combination with PIM as described herein makes it possible to provide shanks with a cutting blade of the utmost accuracy and precision, which are made of stainless steel of the highest quality.

2. Powder injection molding (PIM). The powder injection molding process of the subject invention is particularly advantageous because it facilitates production of a large number of complex curette designs. The methods of the subject invention make it possible to reliably and accurately produce the complex and irregularly shaped dental curette shanks with their cutting blades. The stainless steel alloys and appropriate binders, which can be used in the process of the subject invention, are available to those skilled in the art. The curette shanks of the subject invention can be manufactured according to the subject invention with an expected tolerance of about 0.1% to 0.3%. If so needed or desired, parts manufactured using PIM technology can be given supplementary treatment used for modification of wrought metal products such as heat treatment, plating, and machining.

3. Coating and molding. The cures of the subject invention can be coated with compounds of significant hardness. For example, using the PIM technology described herein, the core of the curette's shank with its cutting blade can be made out of stainless steel that has a high resistance to breakage when used for the scaling and root planing procedure, or when accidentally dropped onto a hard surface. The coating of the curet's core element with a layer of a compound of extreme hardness produces an edge of superior sharpness of long durability. Coating with a compound of extreme hardness also makes the sharpening procedure much easier than the sharpening of a cutting blade of solid metal of extreme hardness. A compound of extreme hardness, e.g., ceramic zirconia, can be molded into the edge portion of the curette's cutting blade for an edge of long-lasting sharpness that does not require sharpening.

#### Manufacturing Process

The four basic steps for making dental cures using the Powder Injection Molding technology of the subject invention are mixing, molding, debinderizing, and sintering.

1. Mixing. Extremely fine (typically less than about 10 microns) prealloyed metal powders can be used in the powder injection molding manufacturing process of the subject invention. A preferred metal alloy powder, which can be used according to the present invention, is commercially available as 17-4 PH Stainless Steel (Metal Powders Products, Inc., Indianapolis, IN). By weight, this stainless steel alloy comprises 15.5% to 17.5% chromium, 3% to 5% nickel, 3% to 5% copper, up to 1% manganese, 0.15% to 0.45% cadmium and tantalum, up to 0.03% sulphur, up to 0.04% phosphorus, up to 0.07% carbon, and balance iron. Other metal and alloy compositions are within the scope of the present invention as long as the selected metal powder is suitable for the injection molding process. Other powders such as ceramics and thermoplastics are within the scope of the present invention.

The metal alloy powder is hot mixed or otherwise blended with a thermoplastic binder, wax, and lubricant. The organic binder may be selected from the group including ethylenevinyl acetate copolymer, polyethylene, atactic polypropylene, polystyrene, polybutyl methacrylate, paraffin wax, carnauba wax, and the like. The blending or



mixing of the metal alloy powder with the organic binder may be conducted in accordance with blending methods known in the art. For example, the metal powder and the organic binder may be hot mixed to produce a thick homogenous blend, which is subsequently cooled and granulated to produce a feedstock. Mixing may be achieved within a pressure type kneader or using a screw-type injection press. This mass is then cooled and finely granulated, and the resulting feed stock is inventoried for production use.

2. Molding. Molding is performed in an injection molding machine. In this machine, the feedstock is first heated until it is able to flow, then injected under relatively low pressure into the mold cavities. The organic binder in the feedstock makes the mixture flow much more easily thereby ensuring that the corners and undercuts of the mold are sufficiently filled. The parts are allowed to cool and solidify, and then ejected. These "green" parts are loaded onto trays for the remainder of the batch processing.

3. Debinderizing. The green parts first enter the debinderizer (a low temperature oven), which sequentially removes most of the various binders from the parts by evaporation leaving behind fully oxidized "brown" parts. The debinderizer utilizes high air flow to sweep the parts and mechanical traps to collect condensates. Because of the complex run profile of temperature ramps and soak times, the entire sequence is preferably microprocessor controlled. Other debinderizing systems, including chemical systems, are also available to those skilled in the art.

4. Sintering. The final step is performed in a high temperature process reactor, where the material assumes its final properties and dimensions. A microprocessor can be used to control the run profile of temperatures, times, and internal oven atmospheres. A combination of reactive and inert gases can be used to tailor the atmosphere to the special requirements of each process sequence. The five basic sequences are: purge, decarburization, reduction, sinter, and cool down. During sintering, when temperatures approach 85% of the alloy's melting point (approximately 1100°C to 1300°C), the metal powders diffuse, densification occurs, and the parts shrink. Since the size and the shape of the original powder particles are rigidly controlled, the shrinkage is uniform along all axes and therefore very predictable. As a result, the finished parts retain the original complex shape of the molded green parts, and very close tolerances can be achieved

(about 0.1% to 0.3%). Shrinkage of the molded parts to their final and fully sintered state ranges from about 15% to 25% depending upon what alloy is being used. The tooling, of course, must be precisely oversized and compensated so that the sintered part shrinks to the desired dimensions.

5           Parts having a complex form are readily produced according to the subject invention with high dimensional accuracy and precision that heretofore has not been possible by conventional processes. The currettes of the subject invention have a unique molecular structure resulting from the production of the currettes by powder injection molding. The molecular structure of these currettes is distinct from the molecular  
10           structure of currettes made using other techniques such as forging or investment cast. The currettes produced according to the methods of the subject invention have highly desirable characteristics as described herein. The currettes of the subject invention also differ from other currettes because of the presence of minute amounts of binding material and slightly increased interstitial space. The currettes of the subject invention are unique compared  
15           to previously-known currettes because of the presence in the currettes of powder injection molded compounds. As used herein, a "powder injection molded compound" refers to any compound that is used to make a dental curette by powder injection molding.

          The currettes made by the methods described herein can have a variety of shapes and/or geometries, which are based upon performance criteria such as stress analyses.  
20           This is advantageous compared to previous currettes, the blades of which have essentially half circle cross sections.

5. Secondary operations. If so desired, parts manufactured by the PIM technology can be further treated using processes such as tumbling for polishing, milling, drilling, honing, and plating. In a preferred embodiment of the subject invention, at least  
25           the edge portion of the curette's cutting blades are coated with a compound of extreme hardness, which makes it possible to give the cutting blade a very sharp edge of the utmost durability. One such compound (ME92 Electrolizing, Inc., Providence, RI) is a USP Class VI certified high chromium composite providing a surface hardness of Rc80. ME92 can be applied directly to the stainless steel with no intermediate layering. Its  
30           unique molecular bonding to stainless steel is absolute and the coating will not chip, flake, or peel. ME92 can be bent, twisted, flexed, or impacted without separating from

the stainless steel. Coating of stainless steel with ME92 increases wear-life and the sharpness of cutting edges of stainless steel instruments. Titanium nitride (Bry Coat, Inc.; Safety Harbor, FL) is a coating compound that has a hardness of Rc85. It is within the scope of the present invention to coat at least the edge portion of the curette's cutting blades with any compound of extreme hardness, or mold a compound of any extreme hardness into at least the edge portion of the curette's cutting blades, e.g. ceramic zirconia, nitrides, and industrial diamonds.

There are several possible protocols for manufacturing the dental curettes using the PIM technology. In one embodiment, the shanks can be fabricated separately and then secured to the instrument handle, which is either manufactured by the PIM procedure or by a conventional process starting with metal tubing or a rod-shaped polymer compound. A further embodiment involves manufacturing the curette comprising the handle and the two shanks with their cutting blade as a one-piece part using injection molding.

Coating at least the edge portion of the curette's cutting blades with a compound of extreme hardness has several advantages. Figure 2A shows a cross-section of a cutting blade which is taken in a plane that is perpendicular to the longitudinal axis of the cutting blade. This blade has never been sharpened, and a coating **52** of the compound of extreme hardness can be seen at the entire perimeter of the cutting blade. An enlargement of one of the side edges **54** in Figure 2A is shown in Figure 2B, which reveals that the coating **52** is intact at the edge portion **54** of the blade.

During the sharpening procedure, the grinding surface **56** of the sharpening element **58** is applied to the edge portion at an angle to the face **26** of the cutting blade as seen in Figure 2C. The grinding of the side portion of the cutting blade's bottom surface **28** will restore a sharp edge of proper geometry **60** as seen in Figure 2D. The enlargement of the sharpened edge seen in Figure 2E also shows that the coating has gradually been ground away **62** during repeated sharpening procedures. The functional cutting edge is still made out of the hard coating compound and always will be following any number of sharpening procedures.

The advantage of a cutting blade with a layer of a compound of extreme hardness over a cutting blade of solid compound of extreme hardness is that, during the sharpening

of the coated instrument, most of the grinding occurs on the much softer core metal **64** as seen in Figure 2E. When sharpening a cutting blade of solid compound of extreme hardness, all grinding is on the compound of extreme hardness. When coating the cutting blade with a compound of extreme hardness, the core metal is selected for its ability to resist breakage during the scaling and root planing procedure, or when accidentally being dropped on a hard surface. It can therefore be advantageous to have dental cures  
5 manufactured the conventional way coated with a compound of extreme hardness.

Molding a compound of extreme hardness into the edge portion of the curette's cutting blades is another of many designs for increasing the durability of the cutting edge, and industrial diamond or ceramic circonia are among the suitable materials.  
10

#### Sharpening Instruments and Procedures

In a preferred embodiment, the curettes of the subject invention are specifically designed to be sharpened in an automated curette sharpening machine. Sharpening machines are described in U.S. Patents Nos. 5,030,091 and 5,197,227 which are  
15 incorporated herein by reference.

The sharpening process involves contacting the curette cutting edge with a sharpening element. In a preferred embodiment, the sharpening element can be mounted on the shaft of an electric motor, which can be positioned along a guide at the base of the machine. Before the sharpening process begins, the curette is secured in an instrument  
20 guide unit. The instrument guide has placement means that, in concert with reference means, positions the flat surface at the arc-center of the cutting blade's tip perpendicular to the axis around which the instrument guide unit and/or the sharpening element rotates during the sharpening procedure, and at the same time the arc-center of the cutting blade's tip is in the axis around which the instrument guide unit and/or sharpening element is  
25 rotating during the sharpening procedure. To achieve the sharpening of the entire cutting edge of the curette, the instrument guide unit moves relative to the sharpening element. In one particular configuration, the instrument guide unit is rotated around a vertical rotation axis to cause the cutting edge to be passed against the sharpening element, first at one side of the blade, then along the semi-circular shaped tip, and finally at the other  
30 side.

The sharpening machine provides complete guidance during the sharpening procedure. In a preferred embodiment, this guidance is achieved using control means. This control means can, for example, be an electromagnet having the appropriate power to bring the curette into contact with the cutting edge of the curette. The combination of these features makes it possible to sharpen curettes with different rake angles by a simple adjustment of the sharpening machine as indicated by a suitable code, which relates to the rake angle of the curette to be sharpened, and also allows for the proper positioning of the curette. In one embodiment of the subject invention, the curettes made by the procedures disclosed herein have a code or other reference means, which facilitates identification of the rake angle and appropriate placement of the instrument in an automated sharpening machine. In a preferred embodiment, the curettes are given a bar code, which identifies the rake angle of the curettes. The bar code can readily be read using standard technology well known to those skilled in the art. The curette may be marked with the bar code during the powder injection molding process, or the bar code may be added to the curette after the curette has been molded. This code makes the identification of the instrument's rake angle easy, simplifies its placement in the sharpening machine, and indicates any need for an adjustment of the sharpening machine to produce a sharp cutting edge for any one of a series of curettes having different rake angles.

While this invention has been described as having preferred design, it is understood that it is capable of further modifications, uses and/or adaptations following the general principles of the invention and including such departures from the present disclosure which come within known or customary practice in the art to which the invention pertains, and as may be applied to the essential features set forth, and fall within the scope of the invention or the limits of the appended claims.

Claims

- 1           1. A dental curette comprising a powder injection molded compound.
- 1           2. The dental curette, according to claim 1, wherein said curette comprises a  
2 handle portion, a shank portion, and a cutting blade portion and wherein at least one of  
3 said portions comprises a powder injection molded compound.
- 1           3. The dental curette, according to claim 2, wherein said handle portion, said  
2 shank portion, and said cutting blade portion comprise a powder injection molded  
3 compound.
- 1           4. The dental curette, according to claim 3, having a unitary construction.
- 1           5. The curette, according to claim 1, wherein said powder injection molded  
2 compound is a metal or metal alloy.
- 1           6. The dental curette, according to claim 1, which comprises a binderizer.
- 1           7. A dental curette comprising a sintered powder compound.
- 1           8. The dental curette, according to claim 7, which further comprises a binderizer.
- 1           9. A dental curette comprising a cutting blade having an inner core of a first  
2 material, wherein at least an edge portion of said cutting blade is provided with a coating  
3 of a second material wherein said second material is harder than said first material.
- 1           10. The dental curette, according to claim 9, wherein the thickness of said coating  
2 is less than the thickness of said inner core.
- 1           11. The dental curette, according to claim 9, wherein said coating has a hardness  
2 of at least about Rc80.

1           12. The dental curette, according to claim 9, wherein said coating is a selected  
2 from the group consisting of chromium composites, nitrides, ceramic, zirconia, and  
3 diamond.

1           13. A method for manufacturing a dental curette, wherein said curette comprises  
2 a handle portion, a shank portion, and a cutting blade portion, wherein said method  
3 comprises forming at least one of said curette portions by powder injection molding.

1           14. The method, according to claim 13, wherein said method comprises  
2           (a) providing a curette mold having at least a shank portion and a  
3 cutting blade portion;  
4           (b) injection molding a feedstock into said curette mold to form a  
5 molded shank and molded cutting blade; and,  
6           (c) attaching a handle to said molded shank.

1           15. A method as defined in claim 14, including the steps of:  
2           a) providing said curette mold with a handle portion disposed on the proximal end  
3 of said shank portion, said shank portion having a cutting blade portion disposed on said  
4 distal end of said shank portion; and  
5           b) injection molding a feedstock into said curette mold to form an injection  
6 molded curette of unitary construction.

1           16. The method, according to claim 13, further comprising the step of coating at  
2 least a portion of the cutting blade with a compound having a hardness greater than the  
3 hardness of said cutting blade.

1           17. A method as defined in claim 16, comprising the steps of:  
2           a) coating at least an edge portion of the injection molded cutting blade with a  
3 coating compound, said coating compound having a hardness greater than the hardness  
4 of the compound of said injection molded cutting blade;

5           b) applying said coating compound in a layer thinner than the thickness of said  
6 injection molded cutting blade;

7           c) whereby, during sharpening of said cutting blade, most of the grinding occurs  
8 on said injection molded compound of said cutting blade, said injection molded  
9 compound being of lesser hardness than said coating compound.

1           18. A method of manufacturing a dental curette, the curette having a handle  
2 including a distal end and a proximal end, the proximal end of a shank disposed on at  
3 least one of said ends of said handle, and a cutting blade disposed on the distal end of  
4 said shank, said method including the steps of:

5           a) providing a curette mold with a shank portion, said shank portion having a  
6 cutting blade portion disposed on the distal end of said shank portion;

7           b) metal injection molding a feedstock into said curette mold to form a metal  
8 injection molded shank and cutting blade of unitary construction; and

9           c) attaching the proximal end of said shank to a handle.

1           19. A method as defined in claim 18, including the steps of:

2           a) providing said curette mold with a handle portion disposed on the proximally  
3 end of said shank portion, said shank portion having a cutting blade portion disposed on  
4 the distal end of said shank portion; and

5           b) metal injection molding a feedstock into said curette mold to form a metal  
6 injection molded curette of unitary construction.

1           20. A method of manufacturing a dental curette, the curette having a handle  
2 including a distal end and a proximal end, a shank disposed on at least one of said ends  
3 of said handle, and a cutting blade disposed on said shank, said method comprising the  
4 steps of:

5           (a) using computer-assisted design for generating blueprints of the  
6 curette;

7           (b) providing a curette mold having at least a shank portion and a  
8 cutting blade portion;



- 9 (c) injection molding a feedstock into said curette mold to form a  
10 molded shank and cutting blade; and,  
11 (d) attaching a handle to said molded shank.

1 21. A method of manufacturing a dental curette, the curette having a handle  
2 including a distal end and a proximal end, a shank disposed on at least one end of said  
3 handle, and a cutting blade disposed on the distal end of said shank, said method  
4 including the steps of:

- 5 a) using computer-assisted design for generating blueprints of a curette;  
6 b) using computer-assisted manufacturing for generating a curette mold with at  
7 least one shank portion, said shank portion having a cutting blade portion disposed on the  
8 distal end of said shank portion;  
9 c) injection molding a feedstock into said curette mold to form an injection  
10 molded shank and cutting blade of unitary construction; and  
11 d) attaching the proximal end of said shank to a handle.

1 22. A method as defined in claim 21, including the steps of:

- 2 a) using computer-assisted design for generating blueprints of a curette;  
3 b) using computer-assisted manufacturing to generate a curette mold with a  
4 handle portion disposed on the proximal end of said shank portion, said shank portion  
5 having a cutting blade portion disposed on said distal end of said shank portion; and  
6 c) injection molding a feedstock into said curette mold to form an injection  
7 molded curette of unitary construction.

1 23. A method of manufacturing a dental curette, the curette having a handle  
2 including a distal end and a proximal end, a shank disposed on at least one end of said  
3 handle, and a cutting blade disposed on the distal end of said shank, said method  
4 including the steps of:

- 5 a) using computer-assisted design for generating blueprints of a curette;

- 6           b) using computer-assisted manufacturing for generating a curette mold with at  
7           least one shank portion, said shank portion having a cutting blade portion disposed on the  
8           distal end of said shank portion;
- 9           c) metal injection molding a feedstock into said curette mold to form a metal  
10          injection molded shank and cutting blade of unitary construction; and
- 11          d) attaching the proximal end of said shank to a handle.

1           24. A method as defined in claim 23, including the steps of:

- 2           a) using computer-assisted design for generating blueprints of a curette;
- 3           b) using computer-assisted manufacturing to generate a curette mold with a  
4           handle portion disposed on the proximal end of said shank portion, said shank portion  
5           having a cutting blade portion disposed on said distal end of said shank portion; and
- 6           c) metal injection molding a feedstock into said curette mold to form a metal  
7           injection molded curette of unitary construction.

1           25. The method, according to claim 13, where said powder comprises a metal or  
2           metal alloy.

1/2

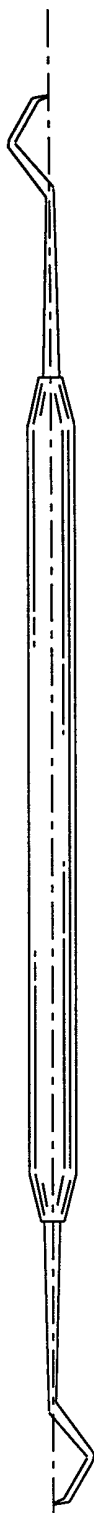

FIG. 1

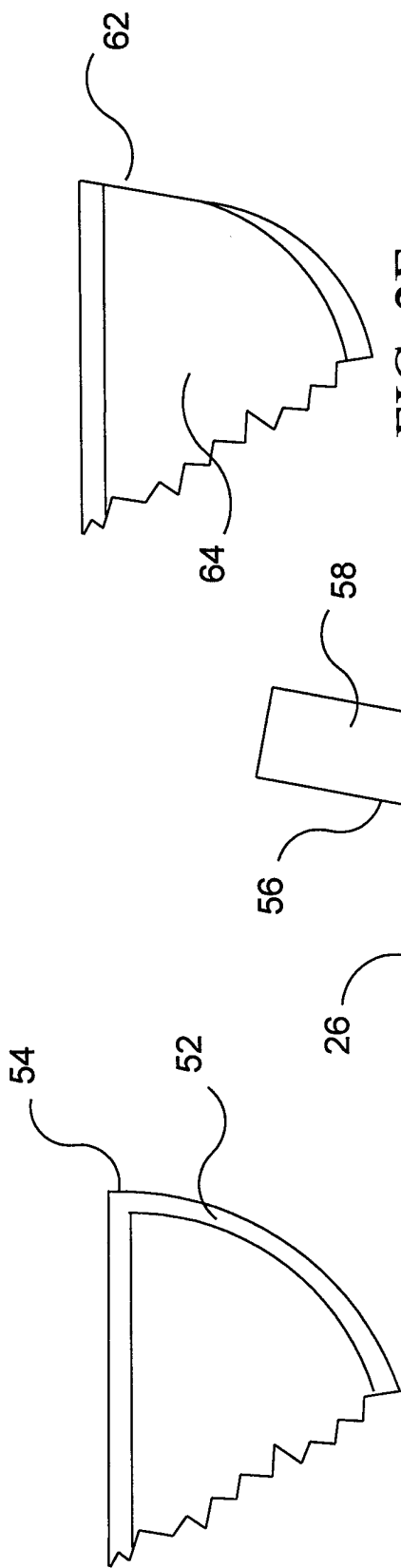

FIG. 2A

FIG. 2B

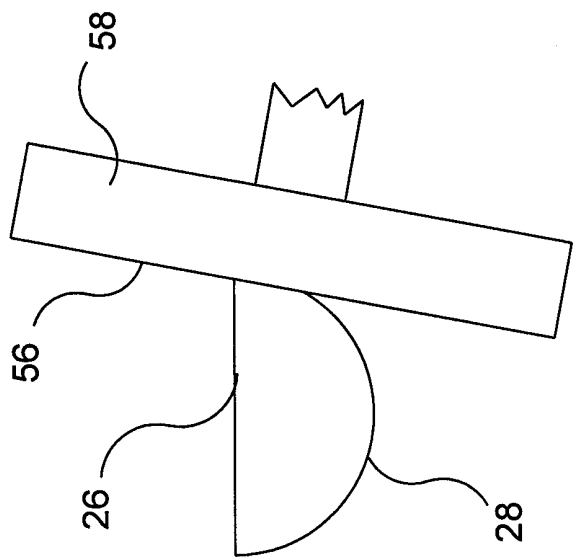

FIG. 2C

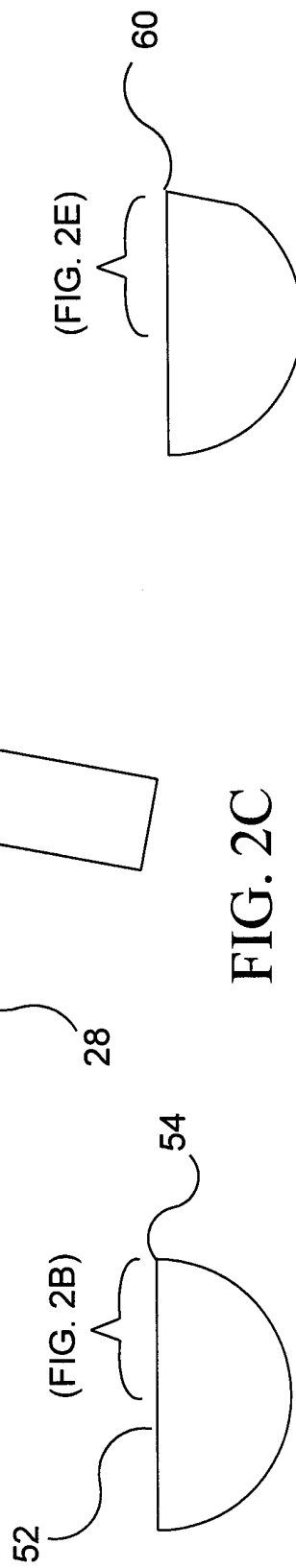

FIG. 2A

FIG. 2D

FIG. 2E

(FIG. 2E)

# INTERNATIONAL SEARCH REPORT

International Application No  
PCT/US 97/11849

**A. CLASSIFICATION OF SUBJECT MATTER**  
IPC 6 A61C3/00

According to International Patent Classification (IPC) or to both national classification and IPC

**B. FIELDS SEARCHED**

Minimum documentation searched (classification system followed by classification symbols)  
IPC 6 A61C B22F

Documentation searched other than minimum documentation to the extent that such documents are included in the fields searched

Electronic data base consulted during the international search (name of data base and, where practical, search terms used)

**C. DOCUMENTS CONSIDERED TO BE RELEVANT**

Category °	Citation of document, with indication, where appropriate, of the relevant passages	Relevant to claim No.
X	EP 0 719 526 A (HIMENO KAZUKO ; TAKARAZUKA PLASTIC INDUSTRY CO (JP)) 3 July 1996 see page 5, line 9 - line 10 see page 5, line 22 - line 26 see page 5, line 58 - line 59 see page 8, line 25 - line 26 see page 15, line 18 - line 20 see figure 3	1-3, 9-17
A	---	4-8, 18-25
A	FR 2 659 846 A (VARAINE JEAN PIERRE ; TRIOLET ALAIN (FR)) 27 September 1991 see page 4, line 3 - line 16 see figures 1, 14	1-4, 9-24
	---	-/--

Further documents are listed in the continuation of box C.       Patent family members are listed in annex.

° Special categories of cited documents :

<p>"A" document defining the general state of the art which is not considered to be of particular relevance</p> <p>"E" earlier document but published on or after the international filing date</p> <p>"L" document which may throw doubts on priority claim(s) or which is cited to establish the publication date of another citation or other special reason (as specified)</p> <p>"O" document referring to an oral disclosure, use, exhibition or other means</p> <p>"P" document published prior to the international filing date but later than the priority date claimed</p>	<p>"T" later document published after the international filing date or priority date and not in conflict with the application but cited to understand the principle or theory underlying the invention</p> <p>"X" document of particular relevance; the claimed invention cannot be considered novel or cannot be considered to involve an inventive step when the document is taken alone</p> <p>"Y" document of particular relevance; the claimed invention cannot be considered to involve an inventive step when the document is combined with one or more other such documents, such combination being obvious to a person skilled in the art.</p> <p>"&amp;" document member of the same patent family</p>
--------------------------------------------------------------------------------------------------------------------------------------------------------------------------------------------------------------------------------------------------------------------------------------------------------------------------------------------------------------------------------------------------------------------------------------------------------------------------------------------------------------------------------------------------------------------------------------	------------------------------------------------------------------------------------------------------------------------------------------------------------------------------------------------------------------------------------------------------------------------------------------------------------------------------------------------------------------------------------------------------------------------------------------------------------------------------------------------------------------------------------------------------------------------------------------------------------------------------------------------------------------------------------------------------------------

Date of the actual completion of the international search <b>5 March 1998</b>	Date of mailing of the international search report <b>13/03/1998</b>
----------------------------------------------------------------------------------	-------------------------------------------------------------------------

Name and mailing address of the ISA European Patent Office, P.B. 5818 Patentlaan 2 NL - 2280 HV Rijswijk Tel. (+31-70) 340-2040, Tx. 31 651 epo nl, Fax: (+31-70) 340-3016	Authorized officer  <b>Chabus, H</b>
----------------------------------------------------------------------------------------------------------------------------------------------------------------------------------------	--------------------------------------------

INTERNATIONAL SEARCH REPORT

International Application No  
PCT/US 97/11849

C.(Continuation) DOCUMENTS CONSIDERED TO BE RELEVANT		
Category	Citation of document, with indication, where appropriate, of the relevant passages	Relevant to claim No.
A	<p>WO 87 05487 A (LINDEN SIGURD) 24 September 1987</p> <p>see page 2, line 28 - page 3, line 1 see page 4, line 36 - page 5, line 15 see figures 1,2,4</p> <p style="text-align: center;">---</p>	<p>1-4, 13-15, 18-24</p>
X	<p>US 4 731 019 A (MARTIN HOWARD) 15 March 1988</p> <p>see column 5, line 43 - line 52 see column 8, line 8 - line 11 see column 8, line 21 - line 32 see figures 1-3</p> <p style="text-align: center;">---</p>	<p>7-12</p>
A	<p>EP 0 499 721 A (ELEPHANT EDELMETAAL BV) 26 August 1992</p> <p style="text-align: center;">---</p>	
A	<p>EP 0.664 998 A (INJEX CORP ; MATSUMOTO DENTAL COLLEGE (JP)) 2 August 1995</p> <p style="text-align: center;">-----</p>	

# INTERNATIONAL SEARCH REPORT

Information on patent family members

International Application No

PCT/US 97/11849

Patent document cited in search report	Publication date	Patent family member(s)	Publication date
EP 0719526 A	03-07-96	JP 8229054 A	10-09-96
-----			
FR 2659846 A	27-09-91	NONE	
-----			
WO 8705487 A	24-09-87	SE 448272 B	09-02-87
		DK 594887 A,B,	12-11-87
		EP 0302860 A	15-02-89
		JP 1501757 T	22-06-89
		US 4882867 A	28-11-89
-----			
US 4731019 A	15-03-88	NONE	
-----			
EP 0499721 A	26-08-92	US 5362438 A	08-11-94
		US 5238751 A	24-08-93
-----			
EP 0664998 A	02-08-95	JP 7252111 A	03-10-95
		US 5613849 A	25-03-97
-----			