

(21) Application No: 0217654.3

(22) Date of Filing: 30.07.2002

(71) Applicant(s):
Fujitsu Limited
(Incorporated in Japan)
1-1 Kamikodanaka 4-chome, Nakahara-ku,
Kawasaki-shi, Kanagawa 211-8588, Japan

(72) Inventor(s):
Yassin Aden Awad
Michiharu Nakamura

(74) Agent and/or Address for Service:
Haseltine Lake & Co
Imperial House, 15-19 Kingsway,
LONDON, WC2B 6UD, United Kingdom

(51) INT CL⁷:
H04L 1/00

(52) UK CL (Edition W):
H4L LDXL L201 L203 L205 L213

(56) Documents Cited:
WO 2001/093471 A1 **WO 2000/001105 A1**
US 2002/0099529 A1

(58) Field of Search:
UK CL (Edition V) **H4L, H4P**
INT CL⁷ **H04L**
Other: **ONLINE: WPI, EPODOC, JAPIO**

(54) Abstract Title: **Adaptive modulation and coding method**

(57) An adaptive modulation and coding method comprises selecting (S7) one of a plurality of different available modulation and coding levels to apply to a signal transmitted from a transmitter to a receiver. The selection is based on a comparison between a signal transmission quality (I_{or}/I_{oc}) and one or more threshold values. The or each threshold value is adjusted (S5, S6) when the signal transmission quality is within a predetermined range of that threshold value, and is maintained unchanged (S3) when the signal transmission quality is outside that range. By maintaining the threshold value unchanged when the signal transmission quality is outside the range of that value the adjustments to the threshold value(s) are limited, whilst still enabling the threshold value(s) to take account of prevailing signal transmission conditions. This leads to improved throughput performance, especially under path conditions involving a single dominant path.

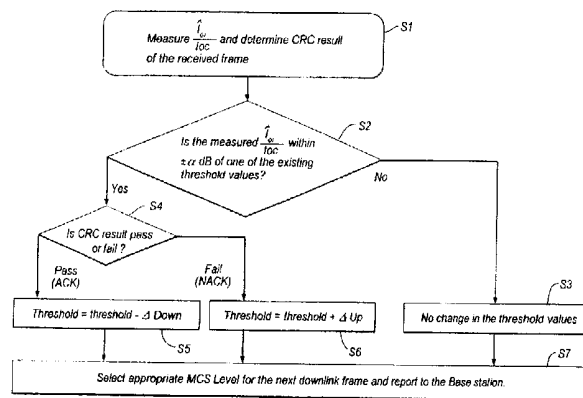

Fig.8

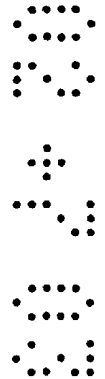
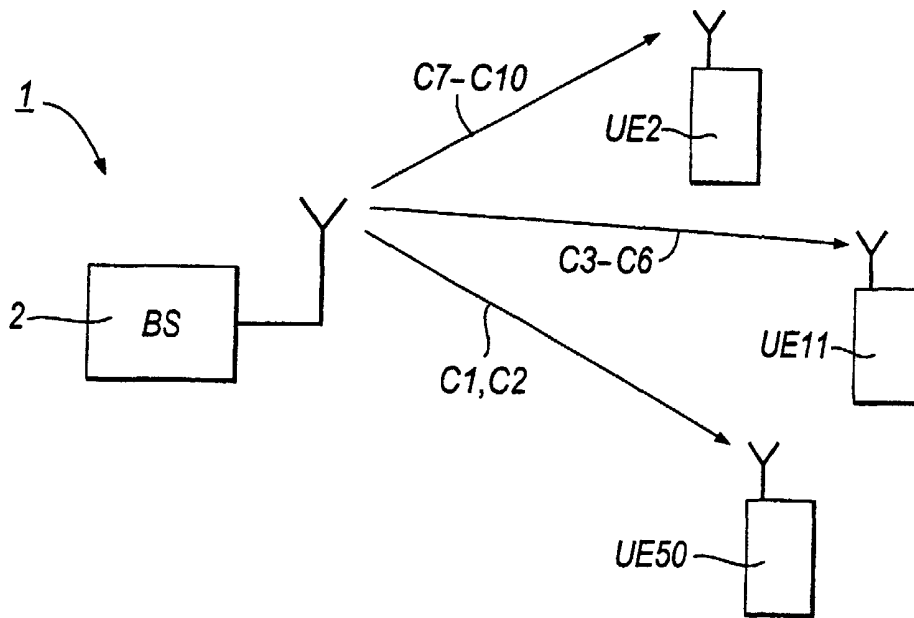

Fig. 1

	TTI 1	TTI 2	TTI 3	TTI 4	TTI 5	TTI 6	TTI 7	TTI 8	TTI 9
Node B 1 Channel Code 1	UE50 Packet 1	UE1 Packet 1	UE3 Packet 1	UE23 Packet 1	UE4 Packet 2	UE6 Packet 1	UE1 Packet 1	UE23 Packet 1	UE7 Packet 1
Node B 1 Channel Code 2	UE50 Packet 2	UE50 Packet 3	UE4 Packet 1	UE1 Packet 2	UE7 Packet 1	UE50 Packet 2	UE4 Packet 1	UE1 Packet 2	UE17 Packet 1
Node B 1 Channel Code 3	UE11 Packet 1	UE50 Packet 4	UE1 Packet 1	UE4 Packet 2	UE23 Packet 2	UE2 Packet 8	UE11 Packet 4	UE15 Packet 1	UE23 Packet 2
Node B 1 Channel Code 4	UE11 Packet 2	UE50 Packet 5	UE50 Packet 10	UE11 Packet 8	UE16 Packet 2	UE9 Packet 2	UE40 Packet 2	UE34 Packet 1	UE9 Packet 3
Node B 1 Channel Code 5	UE11 Packet 3	UE2 Packet 5	UE16 Packet 1	UE9 Packet 1	UE11 Packet 3	UE24 Packet 2	UE43 Packet 2	UE16 Packet 1	UE11 Packet 10
Node B 1 Channel Code 6	UE11 Packet 4	UE11 Packet 5	UE2 Packet 6	UE1 Packet 3	UE4 Packet 1	UE11 Packet 9	UE40 Packet 3	UE11 Packet 5	UE4 Packet 1
Node B 1 Channel Code 7	UE2 Packet 1	UE50 Packet 6	UE50 Packet 11	UE3 Packet 2	UE24 Packet 1	UE2 Packet 8	UE38 Packet 1	UE38 Packet 5	UE50 Packet 14
Node B 1 Channel Code 8	UE2 Packet 2	UE50 Packet 7	UE50 Packet 12	UE11 Packet 9	UE43 Packet 1	UE4 Packet 3	UE38 Packet 2	UE3 Packet 2	UE14 Packet 1
Node B 1 Channel Code 9	UE2 Packet 3	UE50 Packet 8	UE11 Packet 6	UE40 Packet 1	UE50 Packet 13	UE3 Packet 1	UE38 Packet 3	UE40 Packet 1	UE43 Packet 2
Node B 1 Channel Code 10	UE2 Packet 4	UE50 Packet 9	UE11 Packet 7	UE50 Packet 13	UE2 Packet 7	UE43 Packet 2	UE38 Packet 4	UE50 Packet 14	UE2 Packet 9

Fig.2



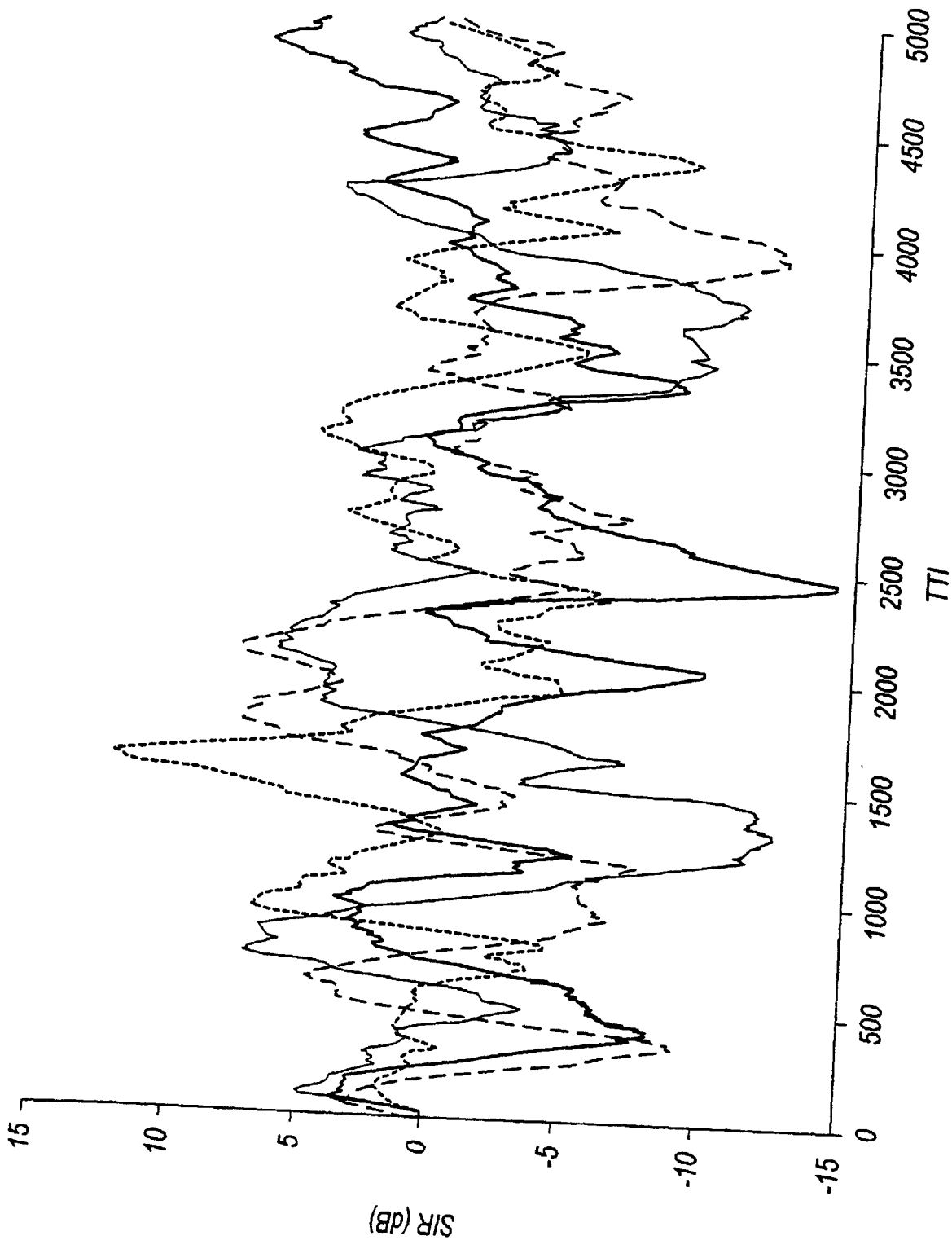
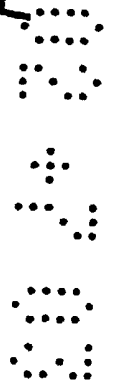

Fig. 3



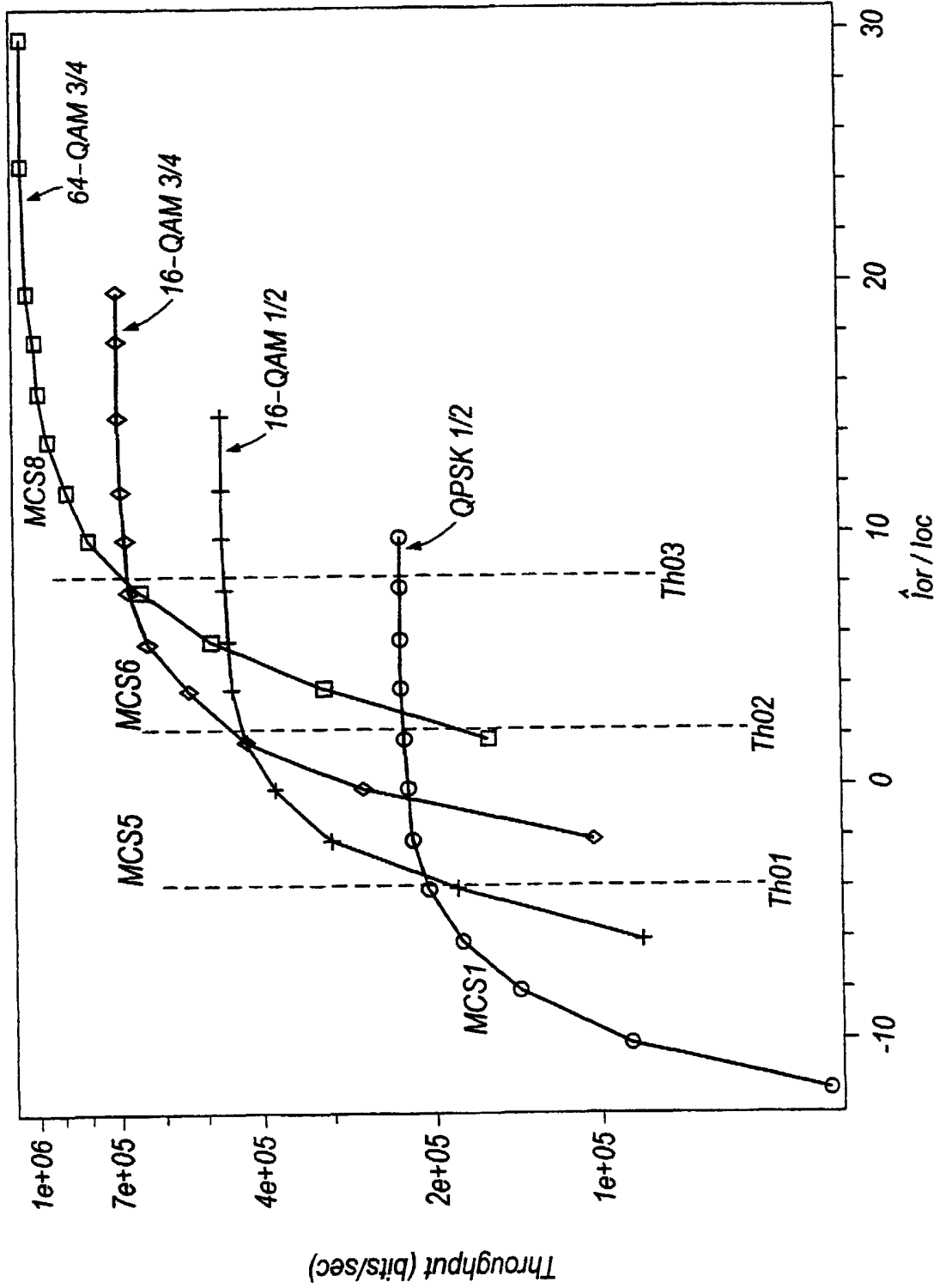

Fig.4

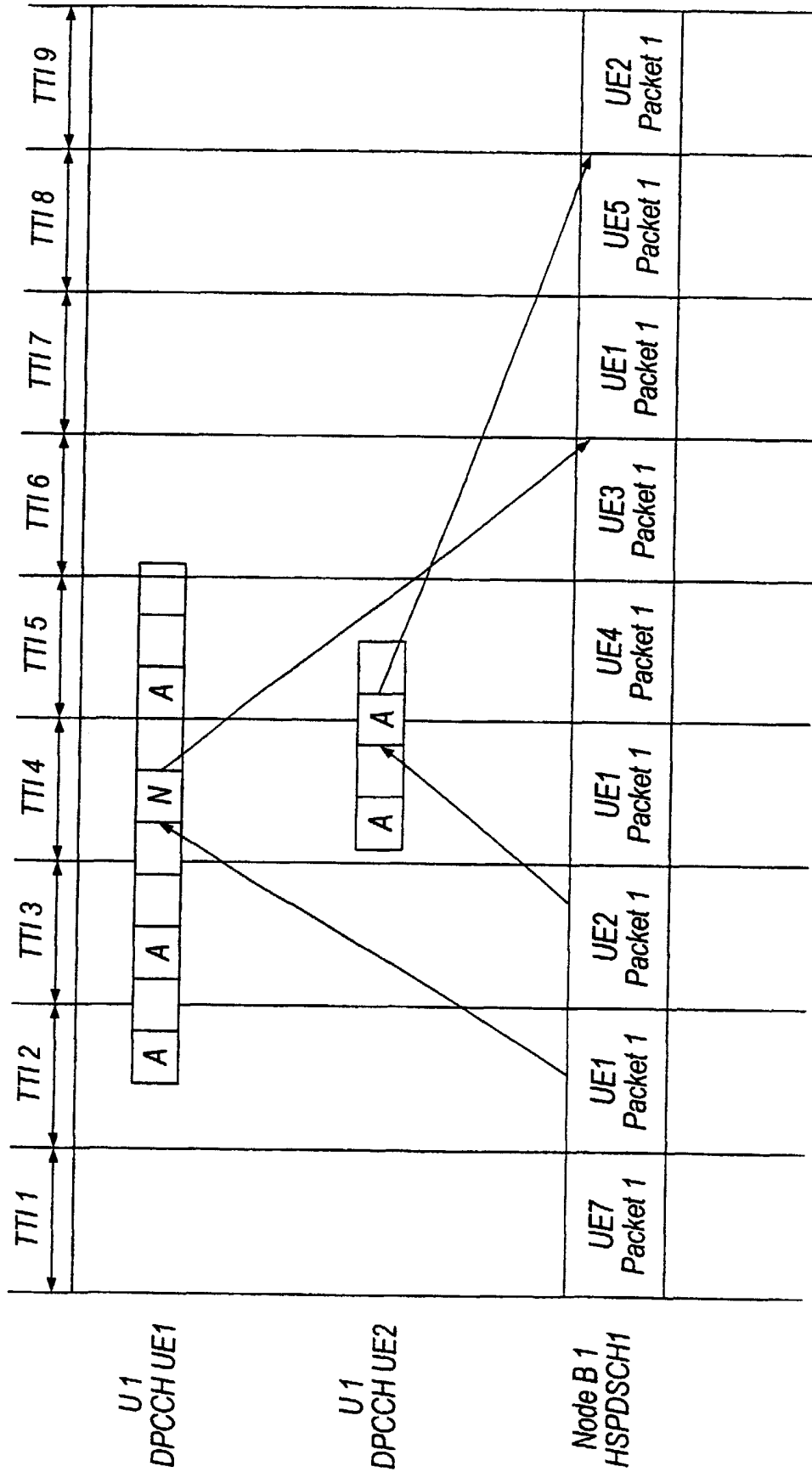
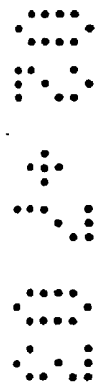

Fig.5



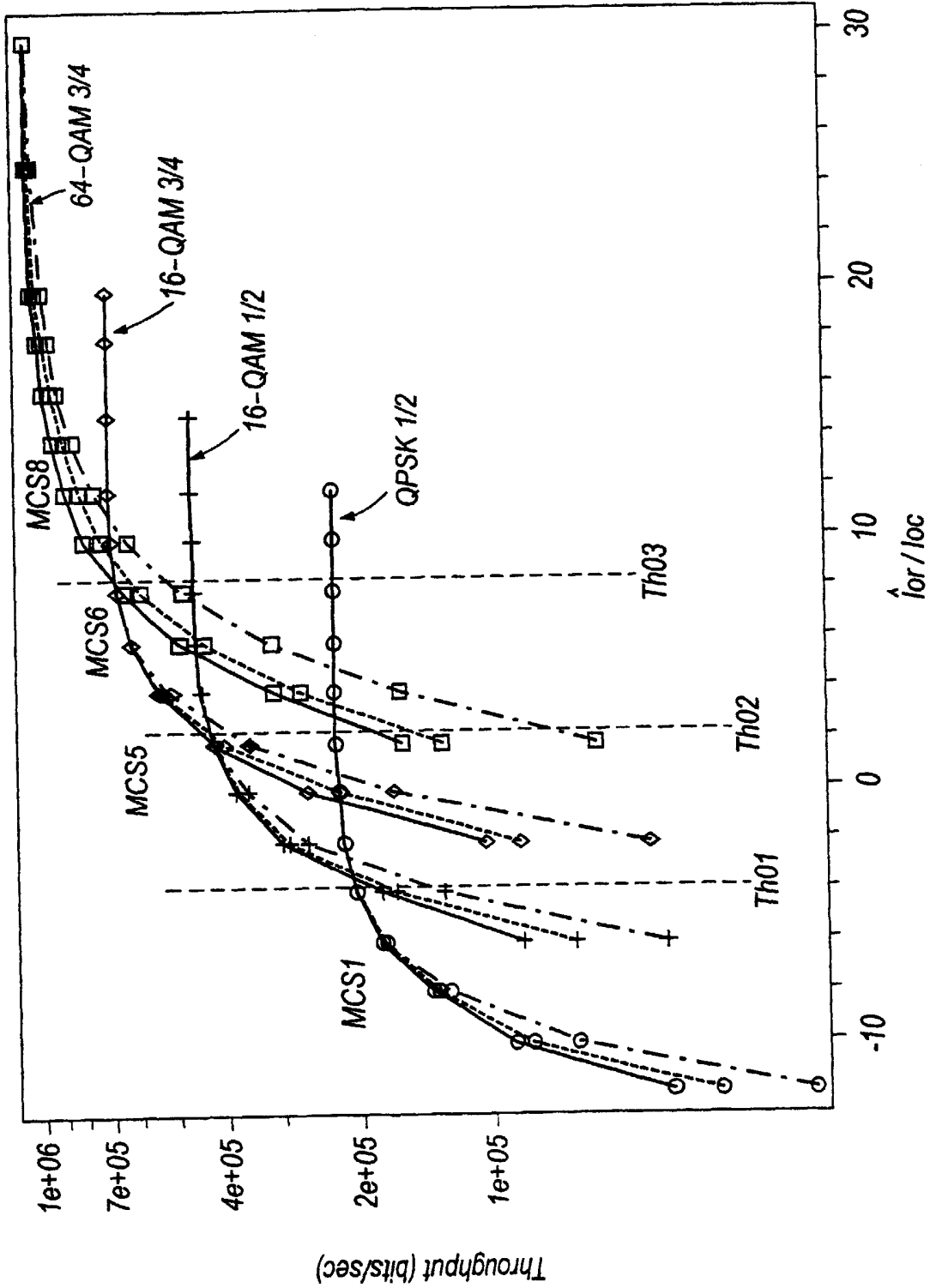

Fig.6



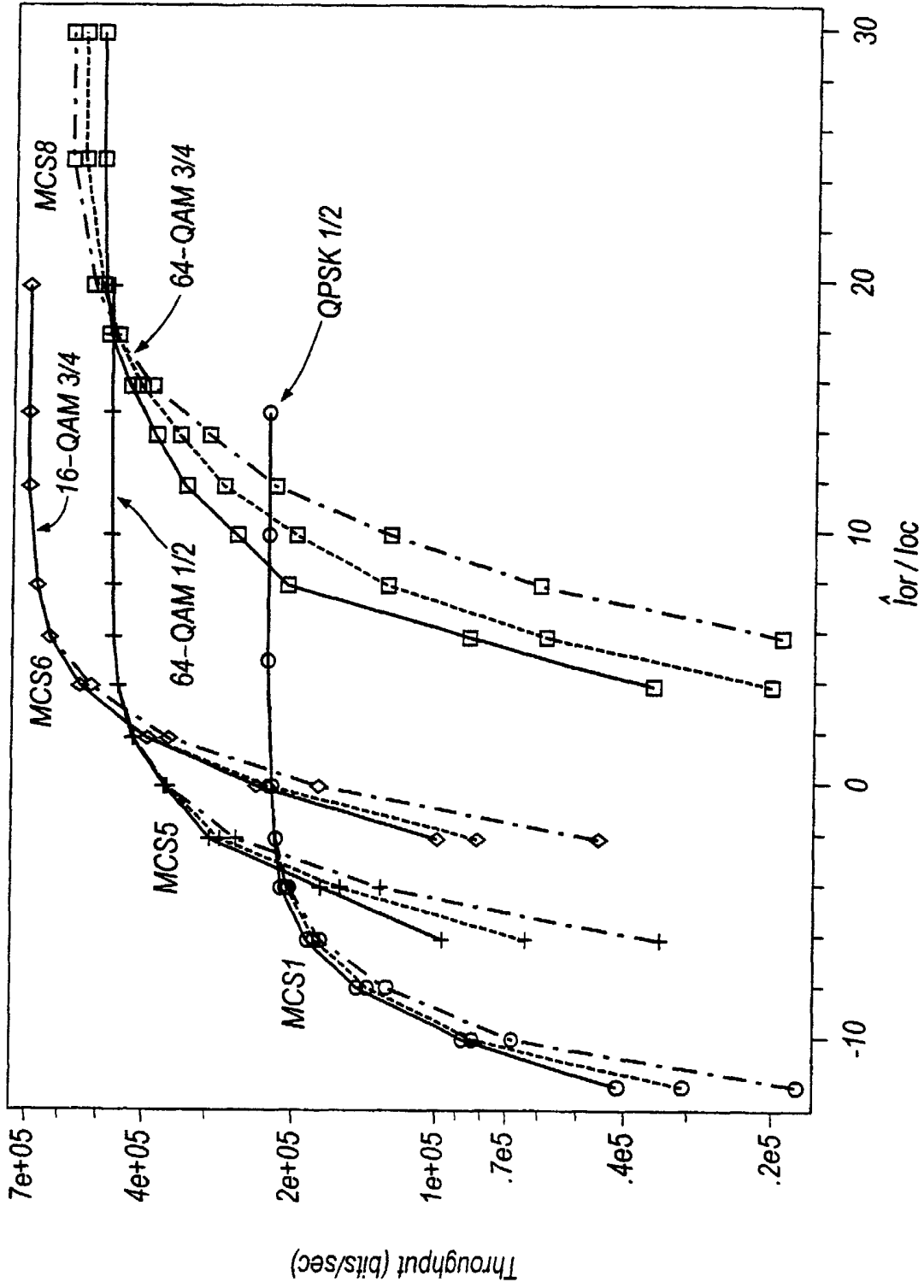

Fig.7



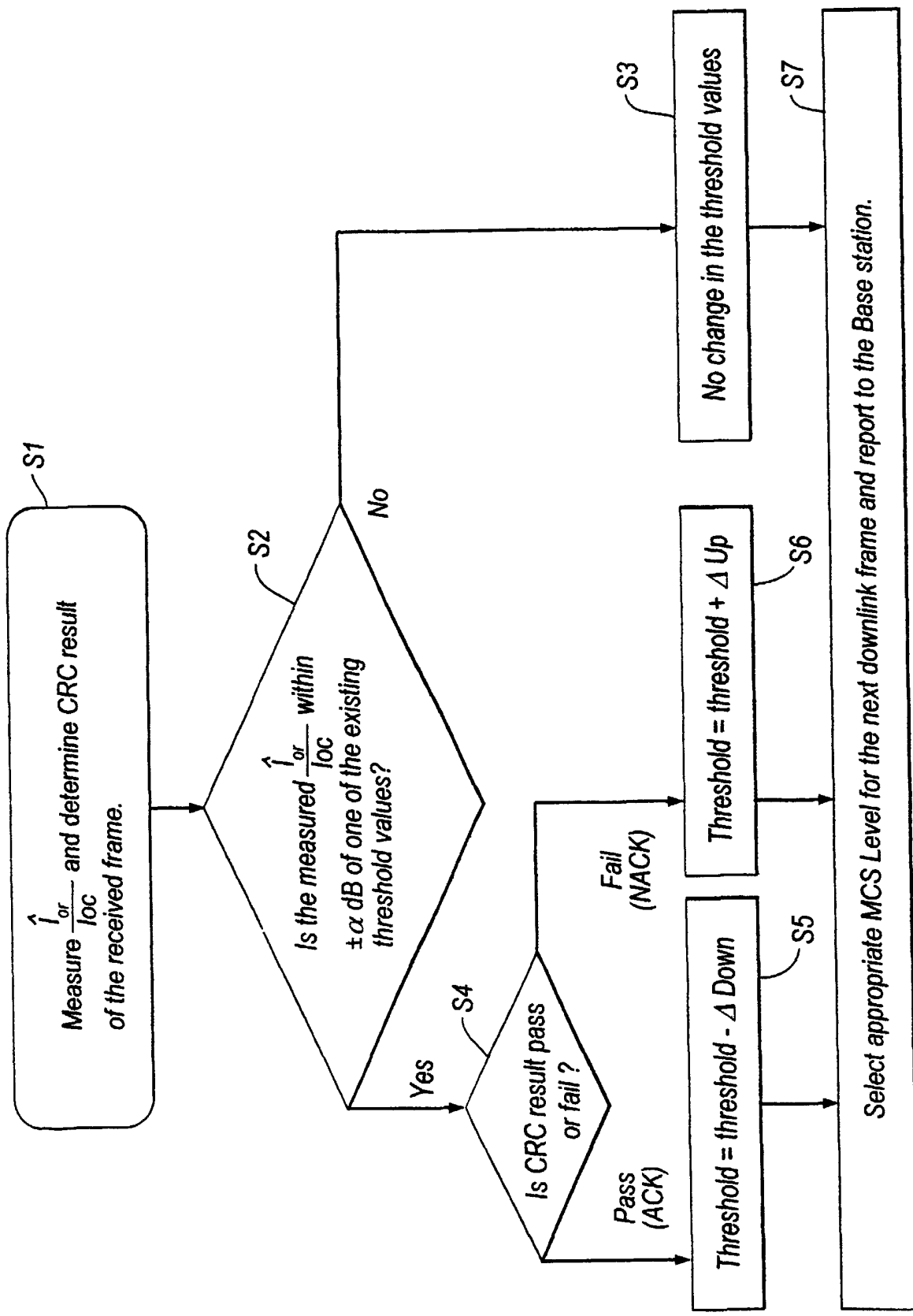

Fig. 8

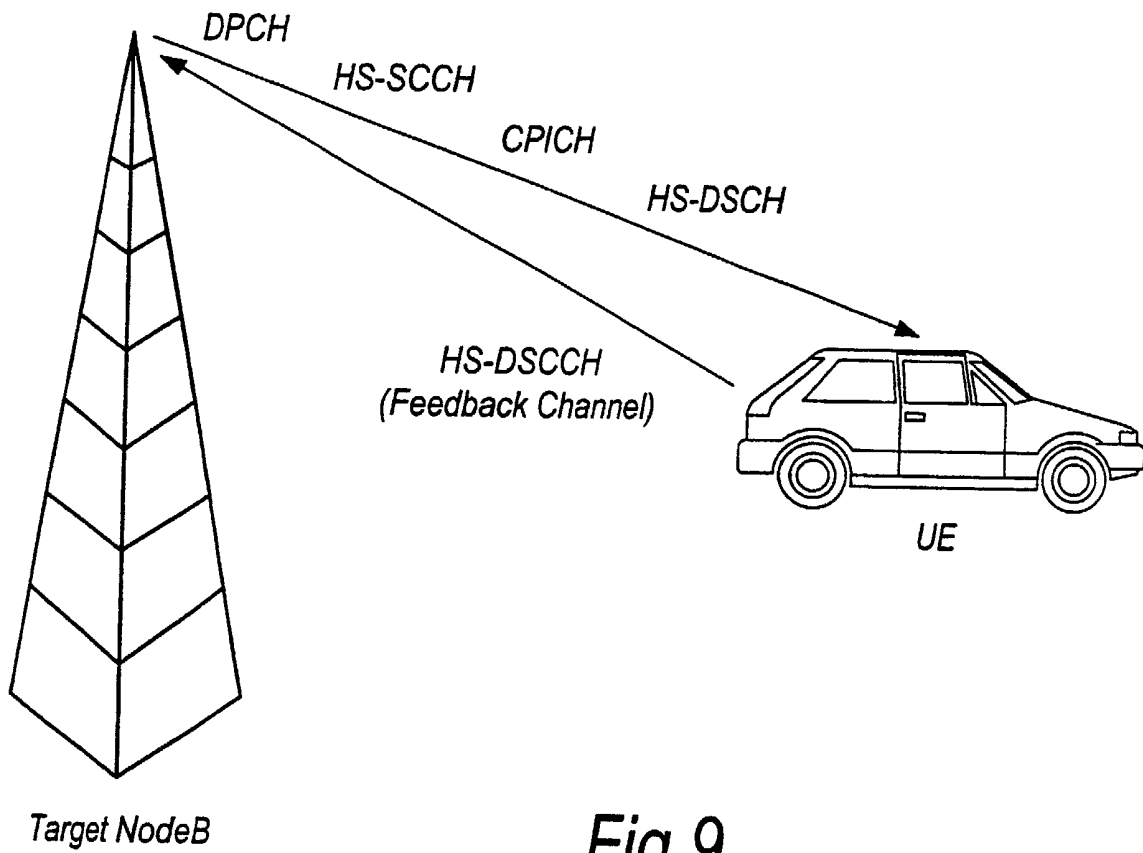

Fig.9



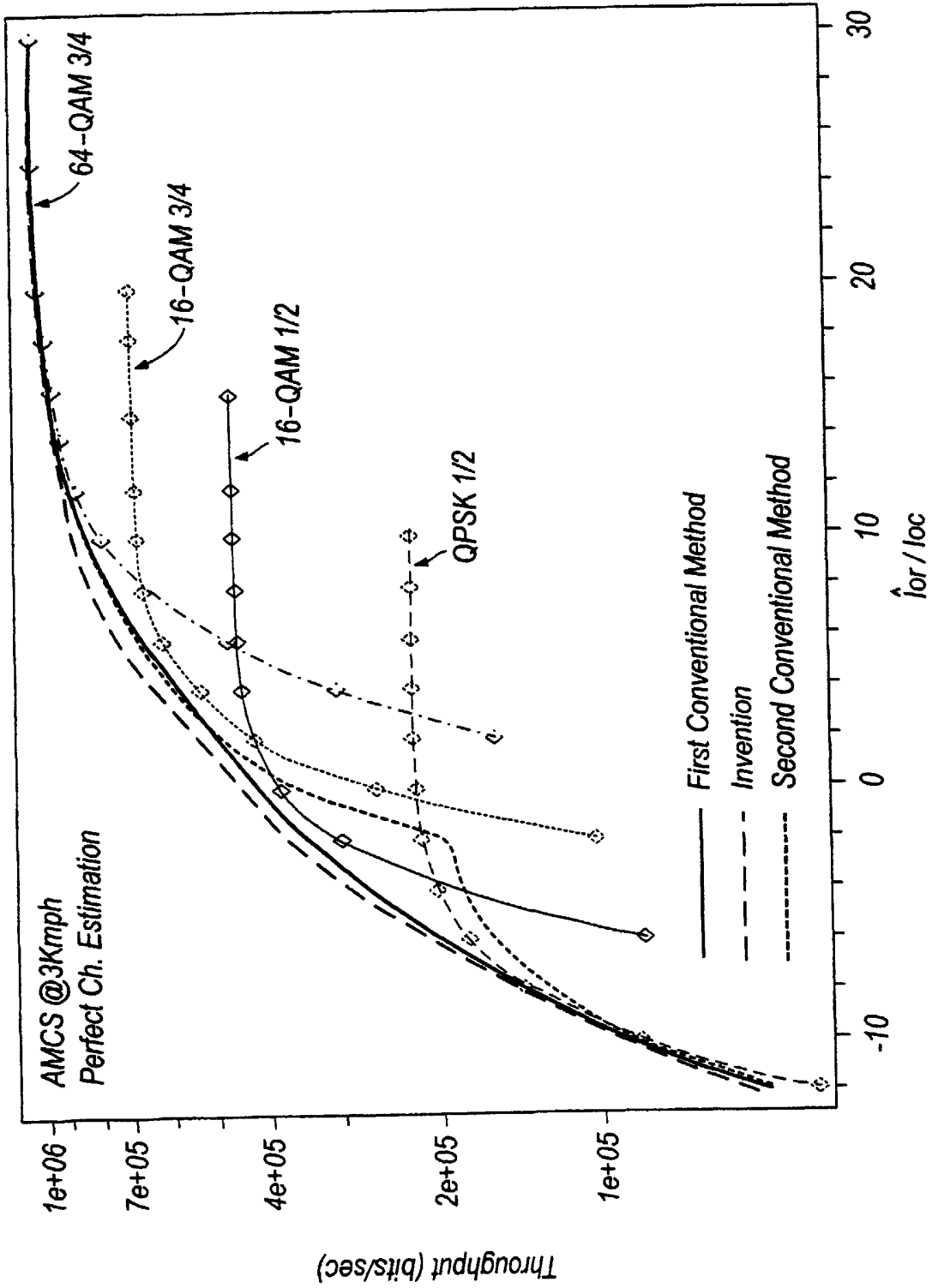

Fig.10



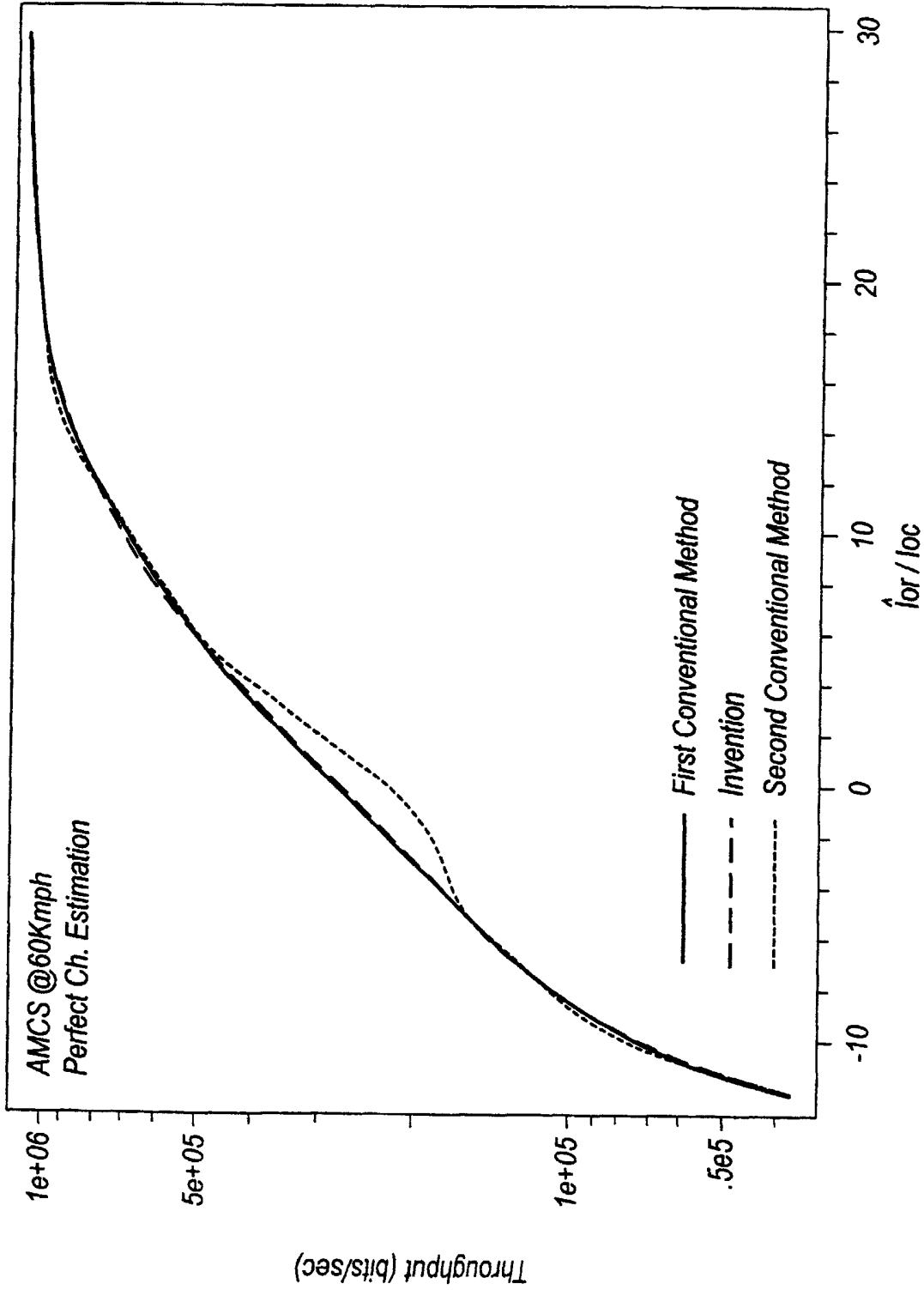

Fig.11

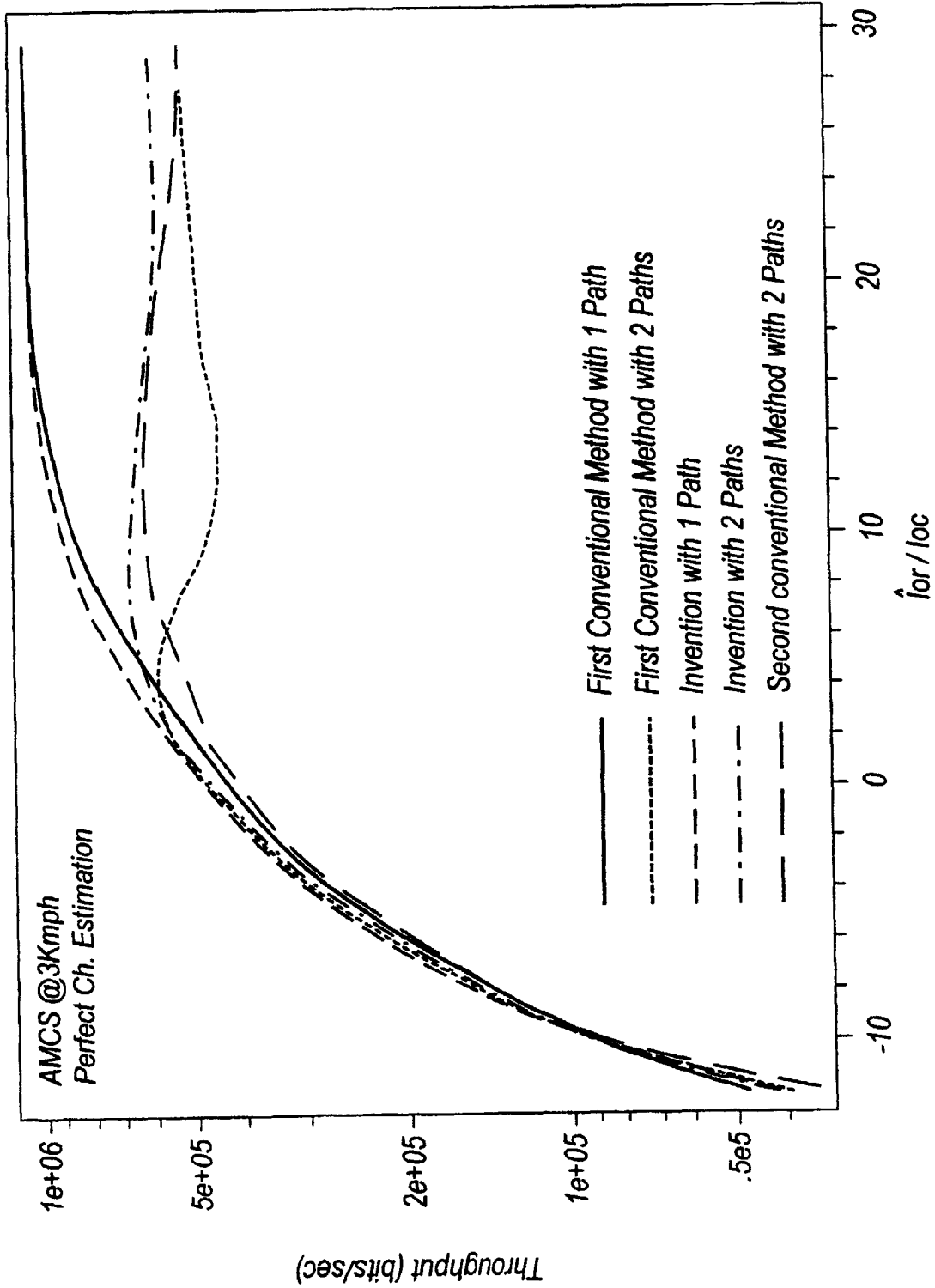
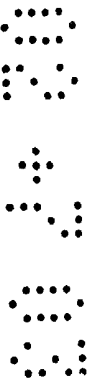

Fig.12



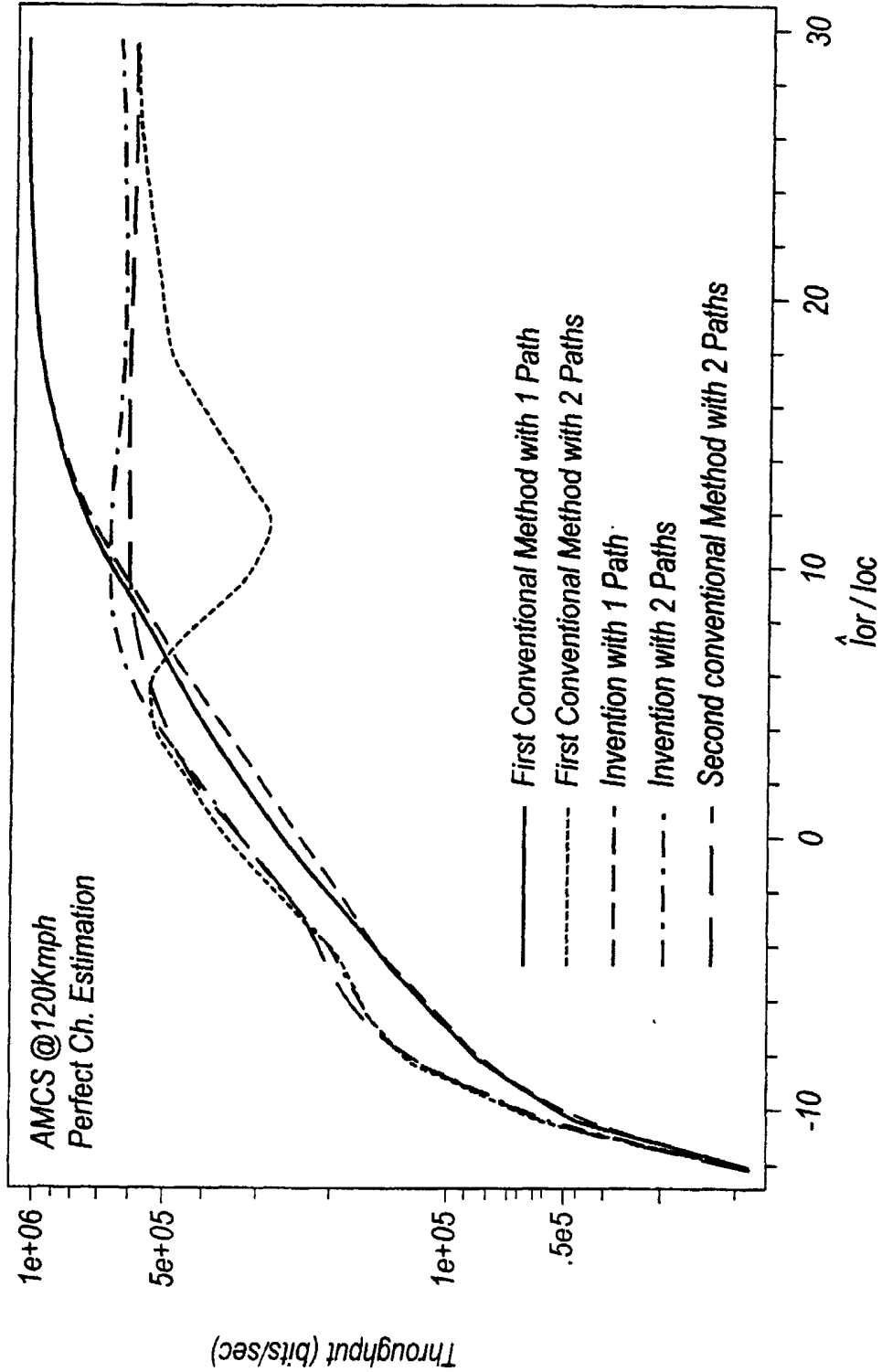
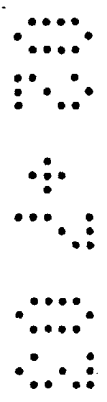

Fig.13



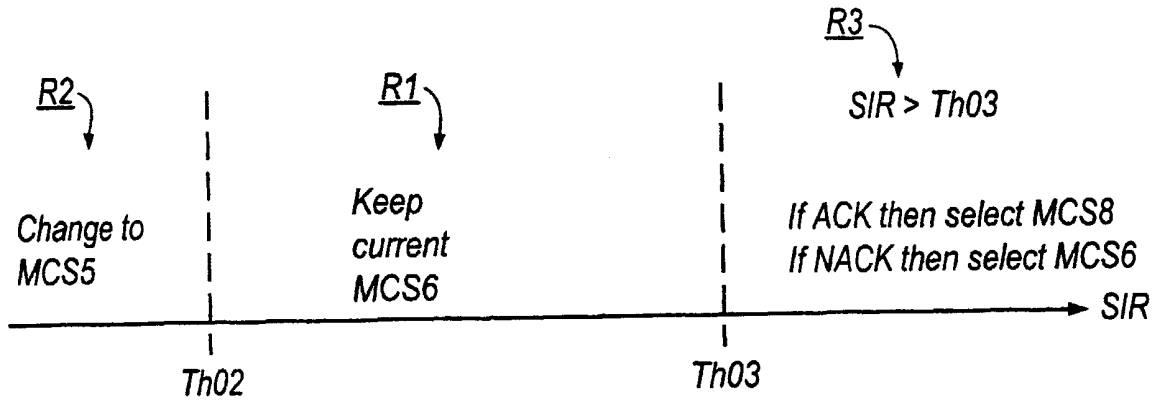

Fig. 14

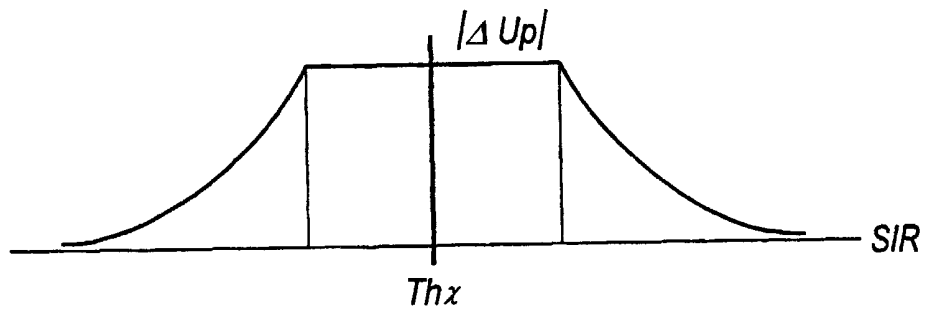

Fig. 15(A)

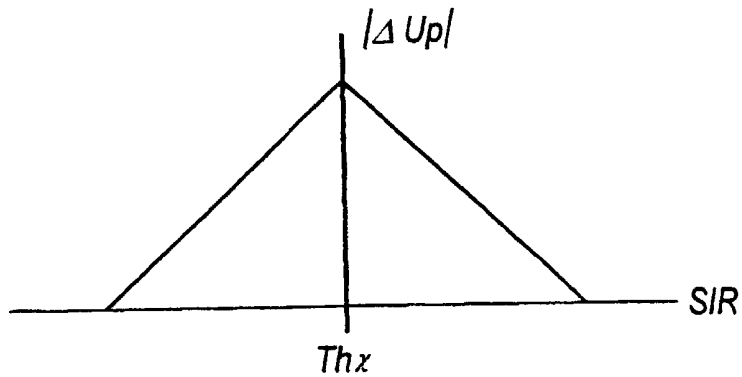
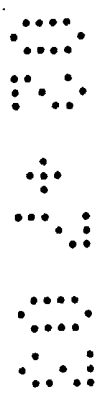

Fig. 15(B)



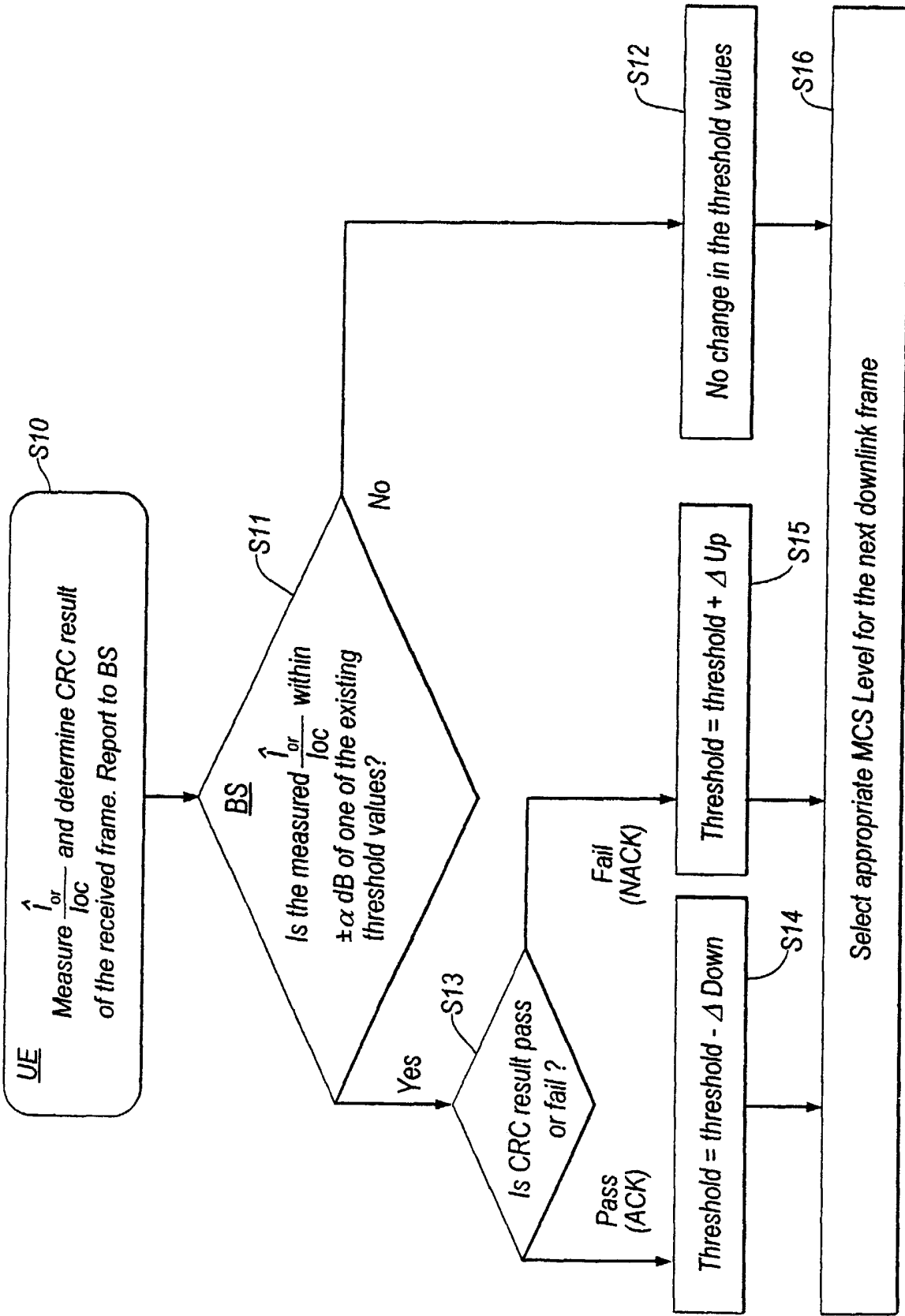
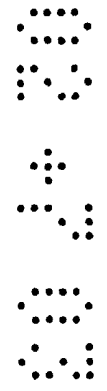

Fig. 16



MCS Number	1	2	3	4	5	6	7	8
Modulation Scheme	QPSK	QPSK	8PSK	8PSK	16QAM	16QAM	64QAM	64QAM
Spreading Factor SF	16	16	16	16	16	16	16	16
Symbols/slot	160	160	160	160	160	160	160	160
Bits/slot	320	320	480	480	640	640	960	960
TTI (ms)	2	2	2	2	2	2	2	2
Number Of slots/frame	3	3	3	3	3	3	3	3
Bits/frame	960	960	1440	1440	1920	1920	2880	2880
TPC, TFCI and Pilot	0	0	0	0	0	0	0	0
Code Length RF	960	960	1440	1440	1920	1920	2880	2880
Padding	0	2	0	2	0	2	0	2
Code Length RM (Rate*DataLength + Tail bit)	960	958	1440	1438	1920	1918	2880	2878
Rate (selected rates)	Rate 1/2	Rate 3/4	Rate 1/2	Rate 3/4	Rate 1/2	Rate 3/4	Rate 1/2	Rate 3/4
Code Length (3*DataLength + 4*(k-1))	1443	2154	2163	3234	2883	4314	4323	6474
K-1	3	3	3	3	3	3	3	3
Data Length	477	714	717	1074	957	1434	1437	2154
CRC Length	24	24	24	24	24	24	24	24
InfoData Length	453	690	693	1050	933	1410	1413	2130
InfoData Rate	226.5 Kbps	345 Kbps	346.5 Kbps	525 Kbps	466.5 Kbps	705 Kbps	706.5 Kbps	1065 Kbps
Number of Multicodes	10	10	10	10	10	10	10	10
Data Rate x Multicodes	2.265 Mbps	3.450 Mbps	3.465 Mbps	5.250 Mbps	4.665 Mbps	7.050 Mbps	7.065 Mbps	10.650 Mbps

Fig.17



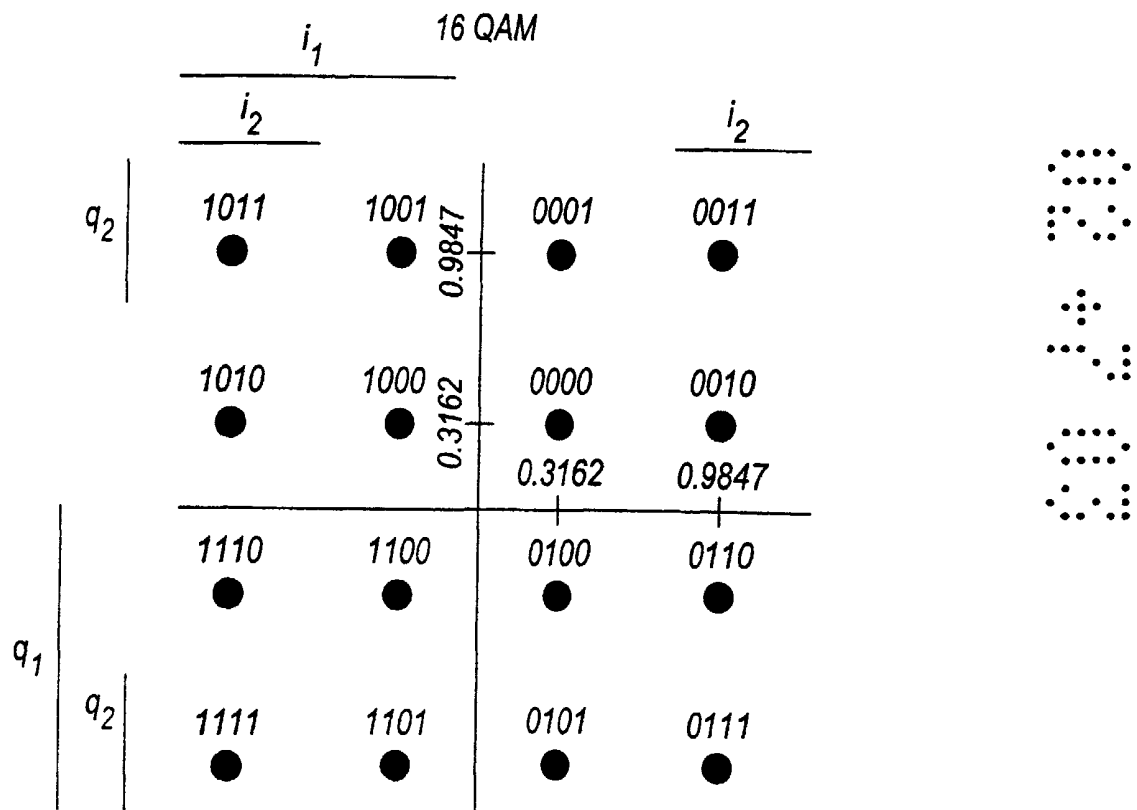
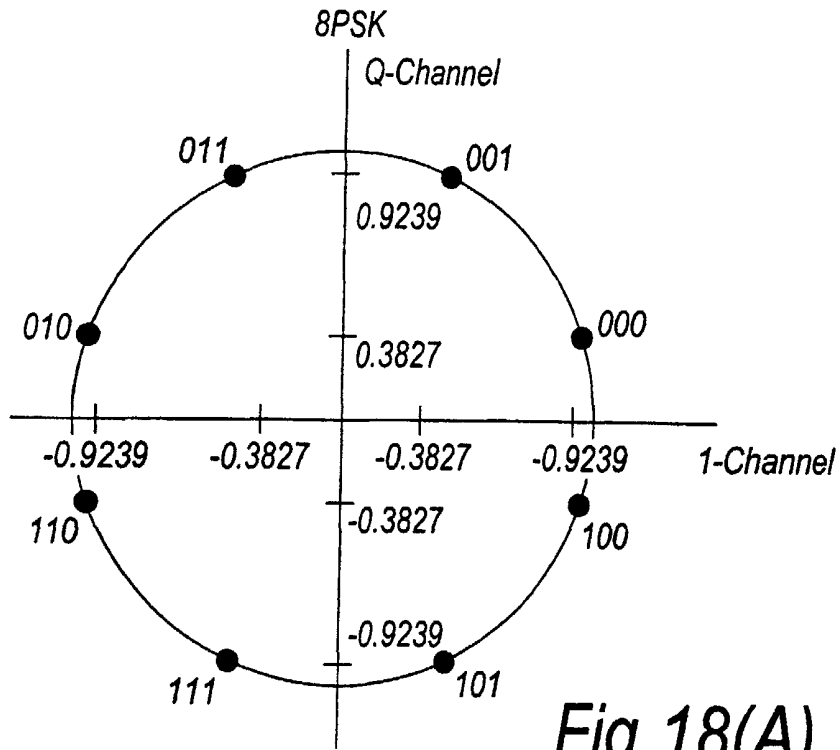

64 QAM

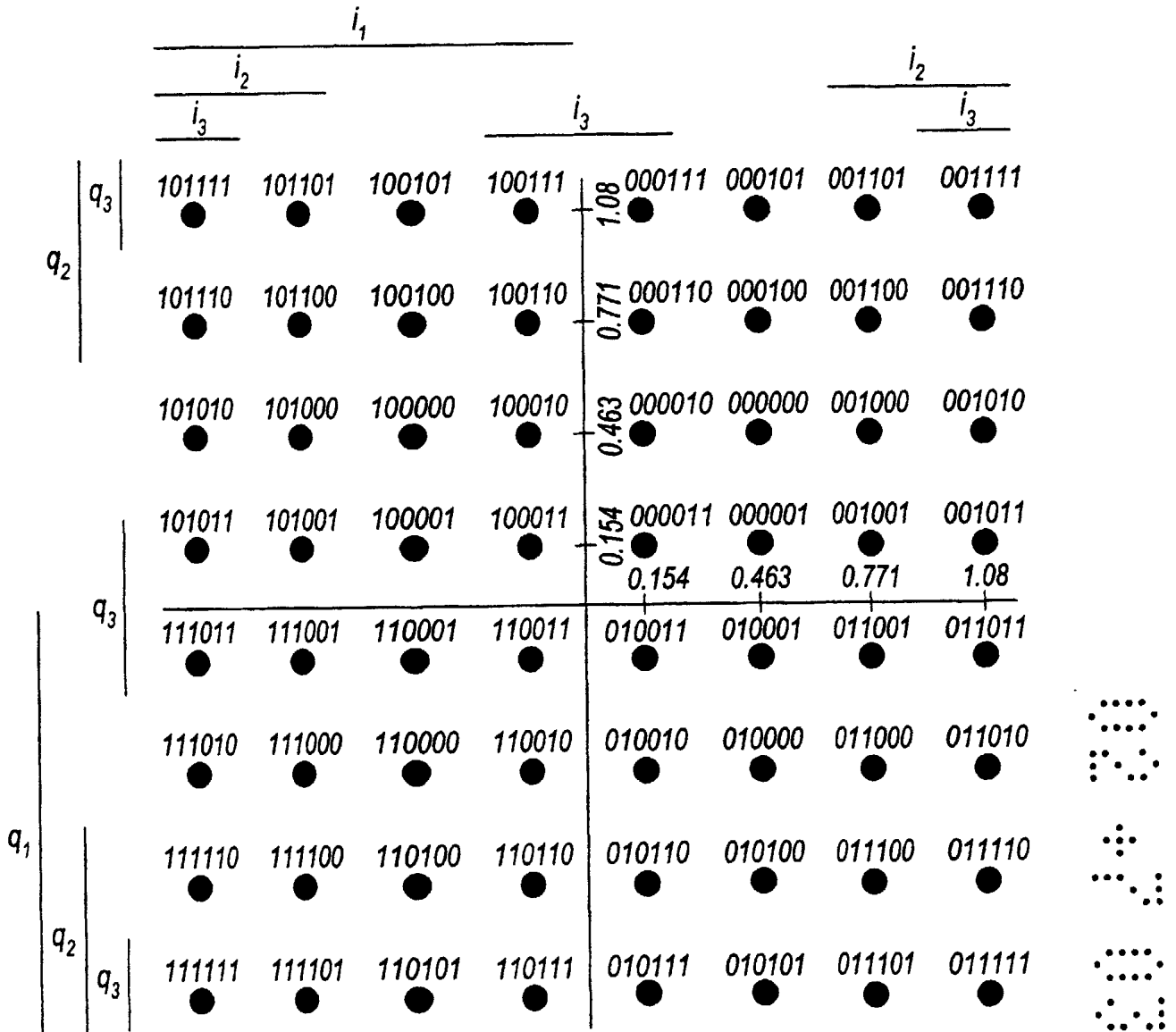

Fig.18(C)

ADAPTIVE MODULATION AND CODING

The present invention relates to adaptive modulation and coding methods and apparatus for use, for example, in wireless communication systems.

Fig. 1 shows parts of a wireless communication system 1. The system includes a plurality of base stations 2, only one of which is shown in Fig. 1. The base station 2 serves a cell in which a plurality of individual users may be located. Each user has an individual user equipment (UE). Only the user equipments UE2, UE11 and UE50 are shown in Fig. 1. Each UE is, for example, a portable terminal (handset) or portable computer.

As is well known, in a code-division multiple access (CDMA) system the signals transmitted to different UEs from the base station (also known as "node B") are distinguished by using different channelisation codes. In so-called third generation wireless communication systems a high speed downlink packet access (HSDPA) technique has been proposed for transmitting data in the downlink direction (from the base station to the UEs). In this technique a plurality of channels are available for transmitting the data. These channels have different channelisation codes. For example, there may be ten different channels C1 to C10 available for HSDPA in a given cell or sector of a cell. In HSDPA, downlink transmissions are divided up into a series of transmission time intervals (TTI) or frames, and a packet of data is transmitted on each different available channel to a selected UE. A new choice of which UE is served by which channel can be made in each TTI.

Fig. 2 shows an example of the operation of the HSDPA technique over a series of transmission time intervals TTI1 to TTI9. As shown in Fig. 2, in TTI1 it

is determined that two packets will be sent to UE50, four packets will be sent to UE11 and four packets will be sent to UE2. Accordingly, two channels are allocated to UE50 and four channels each are allocated to UE11 and UE2. Thus, as shown in Fig. 1, UE50 is allocated channels C1 and C2, UE11 is allocated channels C3 to C6, and UE2 is allocated channels C7 to C10.

In the next transmission time interval TTI2 a new user equipment UE1 is sent one packet, and the remaining UEs specified in TTI1 continue to receive packets.

Thus, effectively the HSDPA system employs a number of parallel shared channels to transmit data in packet form from the base station to the different UEs. This system is expected to be used, for example, to support world wide web (WWW) browsing.

In the HSDPA system, channel state information (CSI) is made available to both the transmitter and the receiver, in order to realise a robust communication system structure. The HSDPA system is intended to increase the transmission rates and throughput, and to enhance the quality of service (QoS) experienced by different users. It transfers most of the functions from the base station controller (also known as the radio network controller or RNC) to the base transceiver station (node B).

The HSDPA system may also use a control technique referred to as an adaptive modulation and coding scheme (AMCS) to enable the base station to select different modulation and/or coding schemes under different channel conditions.

The signal transmission quality for a channel between the transmitter and a receiver (UE) varies significantly over time. Fig. 3 shows an example of the variation of a signal-to-interference ratio (SIR) a

downlink channel for four different users over a series of 5000 TTIs. This plot was obtained by a simulation. As illustrated, for a given UE the range of SIR values may be as much as from around +12dB to -15dB. The SIR value varies due to shadowing, Rayleigh fading, and change in distribution of the mobile UEs, as well as cellular area specifications including the propagation parameters and speeds of UEs.

Fig. 4 is a graph illustrating a relationship between a data transmission rate (throughput) and signal-to-interference ratio for four different modulation and coding combinations, also referred to as modulation-and-coding scheme (MCS) levels. The first three levels (MCS8, MCS6 and MCS5) are all quadrature amplitude modulation (QAM) schemes which differ from one another in the number (64 or 16) of constellation points used. The fourth level (MCS1) uses quadrature phase shift keying (QPSK) as its modulation scheme.

Each level uses coding defined by a coding parameter which, in this example, is expressed as a redundancy rate R . For the first two levels MCS8 and MCS6 the redundancy rate R is $3/4$, and for the third and fourth levels MCS5 and MCS1 the redundancy rate is $1/2$.

As can be seen from Figure 4, for SIR values lower than around -4dB MCS1 (QPSK, $R=1/2$) is the best available option. The characteristic of this level is plotted with circles in the figure.

For SIR values in the range from around -4dB to around +2dB, MCS5 (16QAM, $R=1/2$) provides the best transmission rate. The characteristic for this MCS level is illustrated by crosses in the figure.

For SIR values between around +2dB and +8dB MCS6 (16 QAM, $R=3/4$) provides the best transmission rate. The characteristic for this MCS level is illustrated by diamond points in the figure.

Finally, for SIR values greater than around +8dB, MCS8 (64 QAM, R=3/4) provides the best transmission rate. The characteristic of this combination is illustrated by square points in the figure.

5 In the HSDPA system a technique such as adaptive modulation and coding (AMC) is used to adapt the MCS level in accordance with the variations of the channel condition (e.g. SIR value). Each UE produces a measure of the SIR of a downlink channel from the base station,
10 and reports this measure (SIR value) to the base station. The base station then employs the reported SIR values for each UE, as well as information relating to the system limitations and available MCS levels, to identify the most efficient MCS level for the
15 particular UE. Thus, UEs that have better channels or are located in the vicinity of the base station can employ higher levels of MCS and therefore enjoy higher transmission rates. The selection can be carried out, for example, by imposing thresholds (e.g. Th01, Th02
20 and Th03, as shown in Fig. 4) for moving to the next MCS level. Effectively, the result is a classification of the transmission rates based on the channel quality of each UE.

Ideally, each UE reports a SIR value in every TTI
25 and the base station is capable of setting a new MCS level for each available channel in every TTI.

The HSDPA system may also employ a hybrid automatic repeat request (H-ARQ) technique.

Fig. 5 is a schematic diagram for use in
30 explaining how the H-ARQ technique works. In this example, the technique is a so-called stop-and-wait (SAW) version of the technique. The figure shows packet transmissions in a single downlink channel HSPDSCH1 over a series of successive TTIs, TTI1 to
35 TTI9. In TTI2 a first packet is transmitted to UE1. Upon receiving a packet, each UE checks whether the

transmission was error-free. If so, the UE sends an
acknowledge message ACK back to the base station using
an uplink control channel such as the dedicated
physical control channel (DPCCH). If there was an
5 error in the transmission of the received packet, the
UE sends a non-acknowledge message NACK back to the
base station using the uplink channel.

In the example shown in Fig. 5, the first packet
transmitted to UE1 in TTI2 fails to be received error-
10 free, and accordingly some time later, in TTI4, UE1
sends the NACK message to the base station. In the H-
ARQ technique it is permitted for the next packet
destined for a particular UE to be transmitted without
waiting for the acknowledge or non-acknowledge message
15 of a packet previously transmitted to the same UE.
Thus, none of the transmission timeslots can go idle in
the case of error-free channels, which gives the
ability to schedule UEs freely. System capacity is
saved while the overall performance of the system in
20 terms of delivered data is improved.

For example, as shown in Fig. 5, before the NACK
message for the first packet of UE1 is received by the
base station, the base station transmits a second
packet to UE1 in TTI4. Thus, this second packet for
25 UE1 is transmitted before the first packet for UE1 is
retransmitted in TTI7 in response to the NACK message
for the first transmission of the first packet.

In the H-ARQ technique, an erroneously-received
packet (failed packet) is subject to a so-called chase
30 combining process. In this process a failed packet is
resent by the transmitter and subsequently the receiver
"soft" combines (for example using maximal ratio
combining) all received copies of the same packet. The
final SIR is determined as the sum of the respective
35 SIRs of the two packets being combined. Thus, the

chase combining process improves the SIR of the transmitted packets.

Further information regarding AMC and HARQ techniques may be found in 3GPP TR 25.848 V 4.0.0 (2001-03), Third Generation Partnership Project; Technical Specification Group Radio Access Network; Physical Layer Aspects of UTRA High Speed Downlink Packet Access (release 4), March 2001, the entire content of which is incorporated herein by reference.

10 The switching between different MCS levels has been recognised as a very critical task, and recently there have been various proposals for optimising this switching. For example, in TSG R1-1-0589, TSG-RAN Working Group 1 meeting no. 20, Busan, Korea, May 21 to 15 25 2001, NEC and Telecom MODUS jointly proposed an AMCS technique in which the thresholds for switching between different MCS levels are adjusted based on the ACK/NACK signalling from the UE. If NACK is signalled, the base station increases the thresholds by an upward amount 20 S1. If ACK is signalled, the base station decreases the thresholds by a downward amount S2. The adjustments to the thresholds are limited and, for simplicity, the differences between thresholds may be fixed. The ratio between the upward amount S1 and the 25 downward amount S2 may be determined based on the target error rate.

This AMCS method adjusts the thresholds between MCS levels to try to take into account different operating conditions in the wireless communication 30 system. In particular, the optimum MCS levels under any particular signal conditions depend on the Doppler frequency (i.e. the speed at which the UE is moving) and the multi-path propagation conditions. For example, Fig. 6 shows the effect of the UE speed on the 35 throughput-vs.-SIR characteristic for each of the different MCS levels in Fig. 4. Three lines are

plotted per MCS level: the highest line corresponds to a low UE speed of 3 km/h (Doppler frequency $F_d=5.555\text{Hz}$), the middle line corresponds to a medium UE speed of 60 km/h ($F_d=111.112\text{Hz}$), and the lowest line corresponds to a high UE speed of 120 km/h ($F_d=222.24\text{Hz}$). Fig. 6 shows that throughput declines as UE speed increases. It can also be seen that the optimum thresholds for switching between MCS levels are also changed as the UE speed changes.

Fig. 6 relates to a single-path Rayleigh fading mode. Fig. 7 shows the effect of different UE speeds under path conditions of two equal-gain paths. It can be seen that the characteristics are very different from Fig. 6, and it is clear that the optimum thresholds are changed as the path conditions change.

The method proposed by NEC/Telecom MODUS changes the thresholds as the operating conditions change but the method does not provide a satisfactory solution as it increases or decreases the threshold each time an ACK or NACK message is received, i.e. every frame. This appears to result in relatively poor performance at lower MCS levels for path conditions in which there is effectively a single dominant path, for example in open countryside.

According to a first aspect of the present invention there is provided an adaptive modulation and coding method comprising: selecting one of a plurality of different available modulation and coding levels to apply to a signal transmitted from a transmitter to a receiver, the selection being based on a comparison between a signal transmission quality and a threshold value; and adjusting said threshold value when the signal transmission quality is within a predetermined range of said threshold value, and maintaining the threshold value unchanged when the signal transmission quality is outside that range.

In such an AMCS method the threshold values are adjusted to take account of the prevailing signal transmission conditions but to a more limited extent than in previous proposals. This leads to improved
5 throughput performance, especially under path conditions involving a single dominant path. The signal transmission quality may be a signal-to-interference ratio, and may be measured by the receiver. The signal transmission quality may be
10 measured based on the actual signal to which AMCS is being applied or on another signal, such as a pilot signal.

In the adjusting step the threshold value may be increased by an upward amount when the signal is not
15 received successfully by said receiver, and may be decreased by a downward amount when the signal is received successfully by the receiver. In most communication systems the receiver is required to monitor whether the signal is received successfully, so
20 using this information to help adjust the threshold value does not require any new information to be generated.

For example, in a system in which a cyclic redundancy check (CRC) is carried out on the received
25 signal by the receiver in the adjusting step the threshold value may be increased by an upward amount when the received signal fails the cyclic redundancy check, and may be decreased by a downward amount when the received signal passes the cyclic redundancy check.
30 Again, in such a system in which this information is already being generated, the AMCS method can use this information for the purpose of adjusting the threshold value without increasing the information-generating burden on the system.

35 The upward amount may be different from the downward amount. In a correctly-operating system,

preferably the downward amount is smaller than the upward amount. In a correctly-operating system, the received signal should be received successfully (e.g. pass the CRC) more frequently than it is received unsuccessfully (e.g. fail the CRC). Accordingly, to achieve stable adjustment or stability in the system, the downward amount, which is expected to be applied more often than the upward amount, should be smaller than the upward amount. If the signal transmission conditions are expected to be poor, on the other hand, the downward amount could be set higher than the upward amount.

For example, a ratio of the downward amount to the upward amount may be dependent upon a target error rate of the received signal. This target error rate is a measure of the expected success in receiving the signal. In one embodiment, the ratio of the downward amount to the upward amount is made equal to the ratio of the number of times the signal is received unsuccessfully to the number of times the signal is received successfully, i.e. the target error rate divided by 1 minus that error rate. In this way, the lower the target error rate the lower the ratio between the downward amount and the upward amount.

In one embodiment the downward amount and/or said upward amount is/are dependent upon a difference between said threshold value and said signal transmission quality. For example, the or each amount increases as the difference decreases. This has the effect of magnifying the adjustment amounts near to the threshold value, whilst limiting any adjustments further away from the threshold value.

In a practical system there may be more than two different available levels, in which case there is a threshold value for each pair of adjacent levels. In this case, preferably, each said threshold value is

adjusted only when said signal transmission quality is within a predetermined range of the threshold value concerned.

In this case, the predetermined range for at least one threshold value may be different from the predetermined range for another said threshold value. This may be desirable as different levels have quite different characteristics, at least under some channel conditions. Having the ability to set different predetermined ranges for different thresholds can enable these differences to be taken into account.

The predetermined range may be set by a single value α so that it extends from the threshold value minus α to the threshold value plus α . Alternatively, the range may be set by two different values α_1 and α_2 so that it extends from the threshold value minus α_1 to the threshold value plus α_2 . Again, having the ability to set different values α_1 and α_2 for the predetermined range can enable the different characteristics of MCS levels to be taken into account.

In one embodiment the adjusting step and the selecting step are carried out in the receiver, and the receiver reports the selected level to the transmitter.

In another embodiment the receiver reports the signal transmission quality to the transmitter, and the adjusting step and selecting step are carried out in the transmitter.

The selecting step may be carried out after the adjusting step so that the selection is based on the threshold values after any adjustments have been applied. Alternatively, the selecting step may be carried out before the adjusting step.

In the selecting step, it may also be desirable to make the selection dependent on whether or not the signal was received successfully. For example, if the signal was not received successfully, a move to a

higher level may be prevented, even if the signal transmission quality is now greater than the adjusted threshold value.

The method may be used in any communication system
5 having a transmitter and a receiver in which an AMCS method is applicable. In particular the method may be used in a cellular wireless communication system, in which case the transmitter may be a base station of the wireless communication system, and the receiver may be
10 a user equipment of the system.

The method is particularly useful in an HSDPA system, in which case the signal to which AMCS is applied is a downlink packet access signal.

According to a second aspect of the present
15 invention there is provided adaptive modulation and coding apparatus comprising: level selecting means for selecting one of a plurality of different available modulation and coding levels to apply to a signal transmitted from a transmitter to a receiver, the
20 selection being based upon a comparison between a signal transmission quality and a threshold value; and threshold value adjusting means operable, when the signal transmission quality is within a predetermined range of the threshold value, to adjust the threshold
25 value, and also operable when the signal transmission quality is outside that range, to maintain the threshold value unchanged.

According to a third aspect of the present
invention there is provided a user equipment, for use
30 in a wireless communication system, comprising: level selecting means for selecting one of a plurality of different available modulation and coding levels to be applied by a base station of said system to a downlink signal transmitted from the base station to said user
35 equipment, the selection being based on a comparison between a signal transmission quality and a threshold

value; threshold value adjusting means operable, when said signal transmission quality is within a predetermined range of said threshold value, to adjust said threshold value, and also operable, when said
5 signal transmission quality is outside that range, to maintain said threshold value unchanged; and reporting means for reporting said selected level to said base station.

According to a fourth aspect of the present
10 invention there is provided a base station, for use in a wireless communication system, comprising: report receiving means for receiving from a user equipment of said system a report of a downlink signal transmission quality produced by the user equipment; level selecting
15 means for selecting one of a plurality of different available modulation and coding levels to apply to a downlink signal transmitted from the base station to the user equipment, the selection being based upon a comparison between the reported downlink signal
20 transmission quality and a threshold value; and threshold value adjusting means operable, when the signal transmission quality is within a predetermined range of the threshold value, to adjust the threshold value, and also operable, when the signal transmission
25 quality is outside that range, to maintain the threshold value unchanged.

In practice an AMCS method embodying the invention is likely to be implemented at least in part by a processor in the user equipment or in the base station
30 which runs an operating program. Thus, according to a fifth aspect of the present invention there is provided an operating program which, when run on a processor in a user equipment of a wireless communication system, causes the user equipment to carry out the steps of:
35 selecting one of a plurality of different available modulation and coding levels to be applied by a base

station of said system to a downlink signal transmitted from the base station to said user equipment, the selection being based on a comparison between a signal transmission quality and a threshold value; when said
5 signal transmission quality is within a predetermined range of said threshold value, adjusting said threshold value, and, when said signal transmission quality is outside that range, and maintaining said threshold value unchanged; and reporting said selected level to
10 said base station.

Similarly, according to a sixth aspect of the present invention there is provided an operating program which, when run on a processor in a base station of a wireless communication system, causes the
15 base station to carry out the steps of: receiving from a user equipment of said system a report of a downlink signal transmission quality produced by the user equipment; selecting one of a plurality of different available modulation and coding levels to be applied by
20 the base station to a downlink signal transmitted from the base station to said user equipment, the selection being based on a comparison between the reported downlink signal transmission quality and a threshold value; and when said signal transmission quality is
25 within a predetermined range of said threshold value, adjusting said threshold value, and when said signal transmission quality is outside that range, maintaining said threshold value unchanged.

Further aspects of the present invention can
30 provide control circuitry for use in a user equipment or base station and having means for carrying out the steps of the fifth and sixth aspects.

Reference will now be made, by way of example, to the accompanying drawings, in which:

Fig. 1, discussed hereinbefore, shows parts of a wireless communication system employing a HSDPA technique for downlink transmissions;

Fig. 2 shows an example of the operation of the
5 HSDPA technique in the Fig. 1 system;

Fig. 3 is a graph illustrating an example variation in signal-to-interference ratio of a downlink channel over a series of transmission time intervals for four different UEs in a wireless communication system;

10 Fig. 4 is a graph for use in explaining an adaptive modulation and coding technique;

Fig. 5 is a schematic diagram for use in explaining an automatic repeat request process;

Fig. 6 is a graph corresponding to Fig. 4 for
15 illustrating how a UE speed affects operation of an adaptive modulation and coding technique;

Fig. 7 is another graph for illustrating how different path conditions affect the operation of an adaptive modulation and coding technique;

20 Fig. 8 is a flowchart for use in explaining an AMCS method according to a first embodiment of the present invention;

Fig. 9 is a schematic view of parts of a wireless communication system for explaining signalling used
25 therein;

Figs. 10 to 13 are graphs for comparing operation of an AMC method embodying the present invention with conventional methods under different UE speed and path conditions;

30 Fig. 14 is a schematic diagram for use in explaining a modification to the Fig. 8 method;

Figs. 15(A) and 15(B) are schematic diagrams for use in explaining how to set an upward amount used in the Fig. 8 method;

Fig. 16 is a flowchart for use in explaining an AMCS method according to a second embodiment of the present invention;

Fig. 17 presents a table giving detailed parameters
5 of different MCS levels; and

Fig. 18 presents I-Q diagrams showing constellation points for example MCS levels.

Fig. 8 is a flowchart for use in explaining an AMCS method according to a first embodiment of the present
10 invention. In this embodiment, the UE selects the appropriate MCS level for each frame of the downlink signal and reports the selected level to the base station.

In this example, the method is used to adapt the
15 MCS level of a downlink packet access signal in an HSDPA system.

Fig. 9 is a schematic view for explaining signalling in the first embodiment.

For downlink signalling, four channels are used. A
20 common pilot channel (CPICH) is used to broadcast a signal to all UEs in the cell served by the base station, in order to enable each UE to measure a downlink channel quality based on the CPICH signal. A high-speed downlink shared channel HS-DSCH is used to
25 transmit packet data to a UE. A high-speed shared control channel HS-SCCH is used to carry transport format and resource related information (TFIR). This TFIR is, for example, 8 bits and includes information regarding a channelisation code, a MCS level, and a
30 transport block size. The HS-SCCH also carries HARQ related information. This HARQ information is, for example, 12 bits and includes a HARQ process number, a redundancy version, a new data indicator, and a UE ID. A dedicated physical channel DPCH is optionally
35 employed to transmit a high-speed data control signal

for indicating whether or not the high-speed packet mode is in use.

Uplink signalling is carried out using a high-speed dedicated physical control channel HS-DPCCH. This
 5 channel is used to transmit a channel quality indicator, an HARQ acknowledgement (ACK/NACK) and, in the present embodiment, a MCS level selected by the UE.

Referring back to Fig. 8, the AMCS method according to the first embodiment operates on a frame-by-frame
 10 basis. In each downlink frame (TTI) the method involves the steps S1 to S7.

In step S1, the UE produces a measure of downlink channel quality. This measure is, for example, based on the CPICH and represents a ratio of a received power
 15 \hat{I}_{or} of the CPICH signal to background noise including interference I_{oc} . The ratio \hat{I}_{or}/I_{oc} is a signal-to-interference ratio.

Also in step S1 the UE carries out a cyclic redundancy check (CRC) on the current frame of the HS-
 20 DSCH signal. The CRC result (pass or fail) is needed to generate the ACK/NACK message but, as described below, is also used for another purpose in the present embodiment.

In step S2 the measure of downlink channel quality
 25 produced in step S1 is compared with a set of threshold values held by the UE for MCS selection purposes. There is one such threshold value for each pair of adjacent MCS levels. These threshold values correspond to the threshold values Th01, Th02 and Th03 described
 30 with reference to Fig. 4 above. Based on the comparison, it is determined whether or not the measure of downlink channel quality is within a predetermined range $\pm\alpha$ dB of one of the threshold values. As described later in more detail, α may be different for
 35 different threshold values in the set. Also, for each threshold value there may be two α -values, α_1 and α_2 ,

and the downlink channel quality measure is considered to be within the predetermined range if it is greater than the threshold value less α_1 and less than the threshold value plus α_2 .

5 If the downlink channel quality measure is outside the predetermined range of each of the threshold values, it is determined in step S3 that no change to any of the threshold values is required, and processing proceeds to step S7. In step S7, the downlink channel
10 quality measure is compared with the different threshold values and the appropriate MCS level is selected based on the comparison. Thus, in the example of Fig. 4, if the downlink channel quality measure is greater than the threshold value Th03, MCS8 is
15 selected; if the measure is between the threshold values Th02 and Th03 MCS6 is selected; if the measure is between the threshold values Th01 and Th02, MCS5 is selected, and if the measure is less than the threshold value Th01, MCS1 is selected. The selected MCS level
20 is reported to the base station using the HS-DPCCH.

 If in step S2 the downlink channel quality measure is found to be within the predetermined range of one of the threshold values of the set, processing proceeds to step S4. In step S4 it is determined whether the CRC
25 result in step S1 was a pass or fail. If the result was a pass, i.e. the ACK message was sent from the UE back to the base station, the threshold value that has found to be within the predetermined range is decreased by a downward amount Δ_{Down} in step S5. If, on the
30 other hand, the CRC result was a fail, i.e. the NACK message was sent by the UE back to the base station, the threshold value found to be within the predetermined range is increased by an upward amount Δ_{Up} in step S6.

35 In steps S5 and S6 only the threshold value found to be within the predetermined range of the downlink

channel quality message is changed. Each of the remaining threshold values is left unchanged.

The upward and downward amounts ΔUp and $\Delta Down$ are discussed in detail below.

5 After step S5 or step S6, processing proceeds to step S7 to select the appropriate MCS level for the next downlink frame. In this case, therefore, the selection is made based on the updated set of threshold values.

10 Thus, in the first embodiment the threshold values are adjusted according to whether the downlink signal was received successfully by the UE or not (steps S4 to S6) as in the previous joint proposal of NEC and MODUS Telecom described in the introduction. However,
15 whereas that previous proposal changed the threshold values every frame irrespective of downlink channel quality, the present embodiment only adjusts a threshold value if the downlink channel quality measure is within a predetermined range of that value.
20 Otherwise, no change is made to the threshold values (step S3). This has the effect of limiting the changes to the threshold values in use of the method. Surprisingly, it is found that this simple measure provides a significant improvement in performance of
25 the AMCS method, as will now be explained with reference to Figs. 10 to 13.

Fig. 10 shows a throughput versus downlink channel quality characteristic for a first conventional AMCS method having fixed threshold values (solid line), a
30 second conventional AMCS method according to the joint NEC/MODUS Telecom proposal having adjustable threshold values (dotted line), and an AMCS method embodying the present invention (dashed line). Fig. 10 assumes that the UE is moving at a low speed of 3kph and that the
35 channel estimation carried out by the UE is perfect.

Further it is assumed that the path conditions prevailing between the base station and the UE are such that there is a single dominant path. This kind of path condition arises, for example, in open countryside, as opposed to urban environments. As is evident from Fig. 10, an AMCS method embodying the present invention provides a significant improvement in performance over both conventional methods, over a very wide range of downlink channel qualities (e.g. from -6dB to +16dB). By contrast, the second conventional method has a significant dip in performance under the single path condition for downlink channel qualities in the range from about -10dB to +4dB. This dip is thought to arise from a bunching of the threshold values under the single dominant path condition.

Fig. 11 shows the corresponding results for the three methods, again under single path conditions, but with the UE moving at a medium speed of 60kph. In this case, also, it is evident that the AMCS method embodying the present invention avoids the undesirable dip in the second conventional method.

Fig. 12 shows some results obtained under two-equal-gain path conditions for the three different methods, and also shows (for comparison purposes) the performance of the first conventional method and a method embodying the present invention for single-path conditions. In Fig. 12, the UE is assumed to be moving at 3kph as in Fig. 10.

It can be seen that under two-equal-gain path conditions, a method embodying the present invention outperforms the two conventional methods, as well.

Finally, Fig. 13 shows results corresponding to Fig. 12 but for a UE moving at a very high speed of 120kph. Under these conditions as well, a method embodying the present invention outperforms both the conventional methods, in particular the first

conventional method (fixed thresholds) which has a significant performance dip for downlink channel qualities between +4 and +24dB.

Next, a possible modification of the first
5 embodiment will be described with reference to Fig. 14. This modification relates to the operations carried out in step S7 in Fig. 8. In this modification, as well as making the selection of the MCS level for the next
10 downlink frame based on the updated set of threshold values, the UE also takes account of the CRC result in deciding the MCS level.

Fig. 14 shows the threshold value Th02 used for selecting between MCS5 and MCS6, and the threshold value Th03 used for selecting between MCS6 and MCS8.
15 Assume that the threshold values have been adjusted as necessary in step S5 or S6 or maintained unchanged in step S3 and that the current MCS level is MCS6.

Of course, if the downlink channel quality measure is within a region R1, i.e. between Th02 and Th03, the
20 MCS level is maintained unchanged in step S7. Similarly, if the downlink channel quality measure is within a region R2, i.e. between Th02 and a lower threshold value not shown in Fig. 14, the MCS level is reduced from its current level MCS6 to a lower level
25 MCS5.

If, however, the downlink channel quality measure is within a region R3, i.e. greater than Th03, the MCS level is not automatically increased to MCS8 as in step S7 as previously described. Instead, the MCS level is
30 maintained at its current level MCS6 when the CRC result is a failure, and only increased to MCS8 when the CRC result is a pass. In this way, selection of a higher MCS level, although suggested by the threshold value comparison, is prevented if the signal is not
35 received successfully.

As indicated above, the value α (or pair of values α_1 and α_2) can be different for each threshold value. A typical value of α is 1dB. However, for some threshold values, it may be appropriate to make α large, or at least to make one of α_1 and α_2 large in relation to the other. For example, Fig. 7, discussed in the introduction, showed that when the path conditions are two equal-gain paths, and the fading model is a Rayleigh fading model, MCS6 always achieves a greater throughput than MCS8. In other words, the threshold value Th03 for selecting between MCS6 and MCS8 is redundant, which is equivalent to it having an infinite value. This suggests that Th03 can vary in a very wide range. In this case α_2 for Th03 can be chosen to be arbitrarily large or even infinite.

The upward amount ΔUp and downward amount $\Delta Down$ are preferably set such that

$$\Delta Down = \Delta Up \frac{FER}{1 - FER}, \quad \dots(1)$$

where FER is a target frame error rate.

The target frame error rate may be different for each different threshold value. A FER value of around 10 to 15% may be considered typical. The target FER could alternatively be a target FER value for the currently-selected MCS level, for example a target value for a quality measure in the middle of the band of quality measures over which that MCS level is selected.

It is also possible to make one or both of the upward amount ΔUp and the downward amount $\Delta Down$ dependent upon a difference between the present downlink channel quality measure and the threshold value being adjusted. For example,

$$\Delta U_p = \frac{\Delta U_{p_0}}{\text{Max}\{a, b(|SIR - Thx|)\}} \quad \dots(2)$$

where ΔU_{p_0} is an initial value of ΔU_p , Thx is the threshold value being adjusted, SIR is the present
 5 downlink channel quality measure, and a and b are constants. Here $a > 0$ (a sensible value could be 0.25 to 1) and $b > 0$.

This leads to a relationship between ΔU_p and a difference between SIR and Thx as shown in Fig. 15(A).
 10 The constant b controls the slope of the side portions in Fig. 15(A), and the constant a controls the level at which ΔU_p is capped. The relationship between ΔU_p and $\Delta Down$ may be the same as in equation (1) above.

Alternatively,

$$\Delta U_p = (\Delta U_{p_0}) * \max\{0, \beta - b(|SIR - Thx|)\} \quad \dots(3)$$

where β and b are constants and $b > 0$. The constant β represents a threshold adjustment bandwidth similar to
 20 α , and it is possible to set $\beta = \alpha$. Equation (3) results in a relationship between ΔU_p and the difference between SIR and Thx as shown in Fig. 15(B). Equation (1) may be used to set $\Delta Down$ in this case also.

Equations (2) and (3) have the effect of
 25 increasing ΔU_p (and $\Delta Down$) when the downlink channel quality measure becomes closer to one of the current threshold values.

In the first embodiment described with reference to Fig. 8, the adjustment of the threshold values and
 30 the selection of the MCS level was made in the UE. However, it is not necessary for these operations to be carried out in the UE. It is also possible for one or both of these operations to be carried out in the base station, as will now be described in relation to a
 35 second embodiment of the present invention.

Referring to Fig. 16, in a first step S10 the UE produces a measure of downlink channel quality and also carries out a cyclic redundancy check on the current

frame of the HS-DSCH. The downlink signal quality measure and the CRC result are reported by the UE to the base station via the HS-DPCCH. The base station then carries out steps S11 to S15, which correspond
5 respectively to the steps S2 to S6 in Fig. 6, except that the operations are in this case carried out in the base station rather than in the UE.

In step S16 the base station selects the MCS level for the next downlink frame based on the threshold
10 values (in the same way as the UE did in step S7 in Fig. 8).

In both the first and second embodiments the MCS selection made according to the downlink channel quality measure (step S7 or S16) may be overridden by
15 the base station, for example depending on the amount of data waiting at the base station for transmission to the UE concerned.

Although in the examples described above the available MCS levels were MCS1, MCS5, MCS6 and MCS8, it
20 will be appreciated that any two or more different MCS levels may be made available in embodiments of the present invention. A table showing the characteristics of MCS levels 1 to 8 as an example is presented in Figure 17.

25 As is well known in the art, different modulation schemes involve different numbers of bits per modulated symbol. Quadrature phase shift keying (QPSK) has 2 bits per symbol, 8 phase shift keying (8PSK) has 3 bits per symbol, 16 quadrature amplitude amplitude
30 modulation (16QAM) has 4 bits per symbol, and 64 quadrature amplitude amplitude modulation (64QAM) has 6 bits per symbol. Each scheme results in 2^n constellation points, where n is the number of bits per symbol. The constellation points in I-Q signal space
35 are shown for 8PSK, 16QAM and 64QAM in Figure 18.

Although an example of the present invention has been described above in relation to a wideband CDMA

network having an asynchronous packet mode, it will be appreciated that the present invention can also be applied to any other networks in which AMCS can be used. These networks could be, or could be adapted from, other CDMA networks such as an IS95 network. These networks could also be, or be adapted from other mobile communication networks not using CDMA, for example networks using one or more of the following multiple-access techniques: time-division multiple access (TDMA), wavelength-division multiple access (WDMA), frequency-division multiple access (FDMA) and space-division multiple access (SDMA).

Those skilled in the art will appreciate that a microprocessor or digital signal processor (DSP) may be used in practice to implement some or all of the functions of the base station and/or user equipment in embodiments of the present invention.

CLAIMS:

1. An adaptive modulation and coding method comprising:

5 selecting one of a plurality of different available modulation and coding levels to apply to a signal transmitted from a transmitter to a receiver, the selection being based on a comparison between a signal transmission quality and a threshold value; and
10 adjusting said threshold value when the signal transmission quality is within a predetermined range of said threshold value, and maintaining the threshold value unchanged when the signal transmission quality is outside that range.

2. A method as claimed in claim 1, wherein said
15 signal transmission quality is a signal-to-interference ratio.

3. A method as claimed in claim 1 or 2, wherein said signal transmission quality is measured by the receiver.

20 4. A method as claimed in any preceding claim, wherein in said adjusting step said threshold value is increased by an upward amount when said signal is not received successfully by said receiver, and is decreased by a downward amount when the signal is
25 received successfully by the receiver.

5. A method as claimed in any one of claims 1 to 4, wherein in said adjusting step said threshold value is increased by an upward amount when the signal received by the receiver fails a cyclic redundancy
30 check, and is decreased by a downward amount when the received signal passes the cyclic redundancy check.

6. A method as claimed in claim 4 or 5, wherein said upward amount is different from said downward amount.

35 7. A method as claimed in claim 6, wherein said downward amount is smaller than said upward amount.

8. A method as claimed in any one of claims 4 to 7, wherein a ratio of said downward amount to said upward amount is dependent upon a target error rate of the received signal.

5 9. A method as claimed in any one of claims 4 to 8, wherein said downward amount and/or said upward amount is/are dependent upon a difference between said threshold value and said signal transmission quality.

10 10. A method as claimed in claim 9, wherein the or each said amount increases as said difference decreases.

11. A method as claimed in any preceding claim, having a threshold value for each pair of adjacent said levels, and in said selecting step the selection is
15 based on a comparison between said signal transmission quality and the threshold values.

12. A method as claimed in claim 11, wherein each said threshold value is adjusted only when said signal transmission quality is within a predetermined range of
20 the threshold value concerned.

13. A method as claimed in claim 11 or 12, wherein said predetermined range for at least one said threshold value is different from said predetermined range for another said threshold value.

25 14. A method as claimed in any preceding claim, wherein the adjusting step and the selecting step are carried out in said receiver, and the receiver reports the selected level to the transmitter.

15. A method as claimed in any one of claims 1 to
30 13, wherein the receiver reports said signal transmission quality to the transmitter, and the adjusting step and selecting step are carried out in the transmitter.

16. A method as claimed in any preceding claim,
35 wherein said selecting step is carried out after said adjusting step, and in said selecting step selection of

a higher level, if indicated by said comparison between said signal transmission quality and said threshold value(s) as adjusted or maintained in said adjusting step, is prevented when the signal was not received successfully by the receiver.

17. A method as claimed in any preceding claim, wherein said transmitter is a base station of a wireless communication system, and the receiver is a user equipment of said system.

18. A method as claimed in claim 17, wherein said signal is a downlink packet access signal.

19. Adaptive modulation and coding apparatus comprising:

level selecting means for selecting one of a plurality of different available modulation and coding levels to apply to a signal transmitted from a transmitter to a receiver, the selection being based upon a comparison between a signal transmission quality and a threshold value; and

threshold value adjusting means operable, when the signal transmission quality is within a predetermined range of the threshold value, to adjust the threshold value, and also operable when the signal transmission quality is outside that range, to maintain the threshold value unchanged.

20. A user equipment, for use in a wireless communication system, comprising:

level selecting means for selecting one of a plurality of different available modulation and coding levels to be applied by a base station of said system to a downlink signal transmitted from the base station to said user equipment, the selection being based on a comparison between a signal transmission quality and a threshold value;

threshold value adjusting means operable, when said signal transmission quality is within a

predetermined range of said threshold value, to adjust said threshold value, and also operable, when said signal transmission quality is outside that range, to maintain said threshold value unchanged; and

5 reporting means for reporting said selected level to said base station.

21. A base station, for use in a wireless communication system, comprising:

report receiving means for receiving from a user
10 equipment of said system a report of a downlink signal transmission quality produced by the user equipment;

level selecting means for selecting one of a plurality of different available modulation and coding levels to apply to a downlink signal transmitted from
15 the base station to the user equipment, the selection being based upon a comparison between the reported downlink signal transmission quality and a threshold value; and

threshold value adjusting means operable, when the
20 signal transmission quality is within a predetermined range of the threshold value, to adjust the threshold value, and also operable, when the signal transmission quality is outside that range, to maintain the threshold value unchanged.

22. An operating program which, when run on a
25 processor in a user equipment of a wireless communication system, causes the user equipment to carry out the steps of:

selecting one of a plurality of different
30 available modulation and coding levels to be applied by a base station of said system to a downlink signal transmitted from the base station to said user equipment, the selection being based on a comparison between a signal transmission quality and a threshold
35 value;

when said signal transmission quality is within a predetermined range of said threshold value, adjusting said threshold value, and, when said signal transmission quality is outside that range, and
5 maintaining said threshold value unchanged; and
reporting said selected level to said base station.

23. An operating program which, when run on a processor in a base station of a wireless communication
10 system, causes the base station to carry out the steps of:

receiving from a user equipment of said system a report of a downlink signal transmission quality produced by the user equipment;
15 selecting one of a plurality of different available modulation and coding levels to be applied by the base station to a downlink signal transmitted from the base station to said user equipment, the selection being based on a comparison between the reported
20 downlink signal transmission quality and a threshold value; and

when said signal transmission quality is within a predetermined range of said threshold value, adjusting said threshold value, and when said signal transmission
25 quality is outside that range, maintaining said threshold value unchanged.

24. An adaptive modulation and coding method substantially as hereinbefore described with reference to Figs. 8 to 18 of the accompanying drawings.

30 25. Adaptive modulation and coding apparatus substantially as hereinbefore described with reference to Figs. 8 to 18 of the accompanying drawings.

26. A user equipment for use in a wireless communication system substantially as hereinbefore
35 described with reference to Figs. 8 to 18 of the accompanying drawings.

27. A base station for use in a wireless communication system substantially as hereinbefore described with reference to Figs. 8 to 18 of the accompanying drawings.

5 28. An operating program for a processor in a user equipment or in a base station of a wireless communication system substantially as hereinbefore described with reference to Figs. 8 to 18 of the accompanying drawings.

10



INVESTOR IN PEOPLE

Application No: GB 0217654.3
Claims searched: all

Examiner: Nigel Hall
Date of search: 16 January 2003

Patents Act 1977 : Search Report under Section 17

Documents considered to be relevant:

Category	Relevant to claims	Identity of document and passage or figure of particular relevance
A		WO 01/93471 A1 (MOTOROLA)
A		WO 00/01105 A1 (MOTOROLA)
A		US 2002/0099529 A1 (TANG)

Categories:

X Document indicating lack of novelty or inventive step	A Document indicating technological background and/or state of the art
Y Document indicating lack of inventive step if combined with one or more other documents of same category.	P Document published on or after the declared priority date but before the filing date of this invention.
& Member of the same patent family	E Patent document published on or after, but with priority date earlier than, the filing date of this application

Field of Search:

Search of GB, EP, WO & US patent documents classified in the following areas of the UKC^v:

H4L, H4P

Worldwide search of patent documents classified in the following areas of the IPC⁷:

H04L, H04Q

The following online and other databases have been used in the preparation of this search report:

Online: WPI, EPODOC, JAPIO