

Aug. 26, 1969

W. J. CRENSHAW ET AL

3,463,199

SELVAGE-FORMING APPARATUS FOR DOUBLE FABRIC LOOMS

Filed Sept. 15, 1966

4 Sheets-Sheet 1

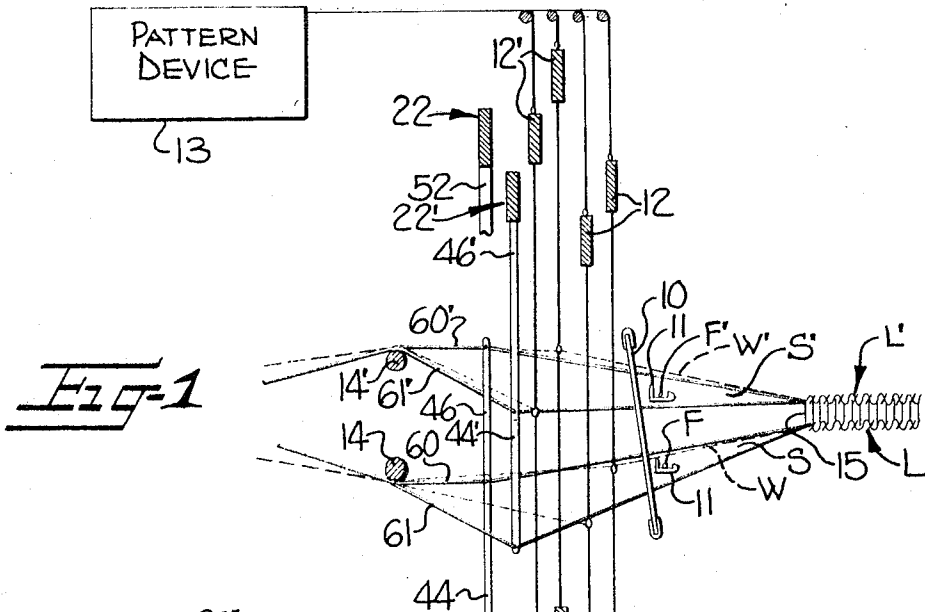

Fig-1

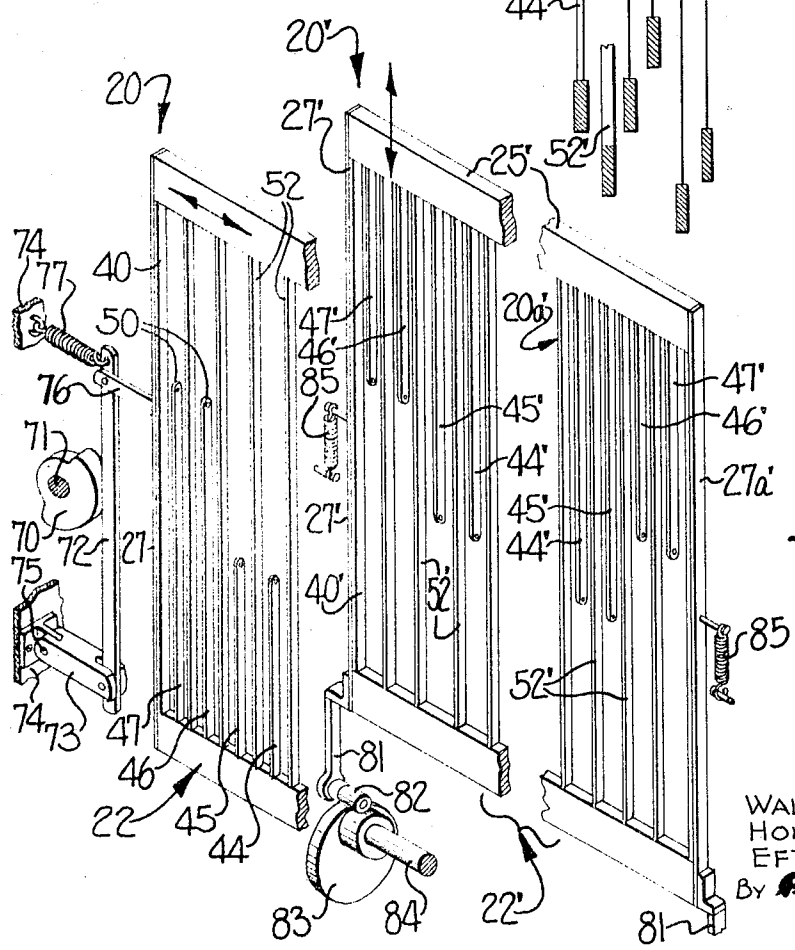

Fig-2

INVENTORS:  
 WALTER J. CRENSHAW,  
 HOKE S. HICKS and  
 EFTON O. OAKES  
 By *Rennett, Bell, Selfer*  
*Park & Heard*

ATTORNEYS

SELVAGE-FORMING APPARATUS FOR DOUBLE FABRIC LOOMS

Filed Sept. 15, 1966

4 Sheets-Sheet 2

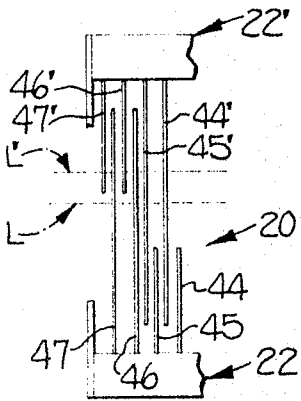

Fig-3A

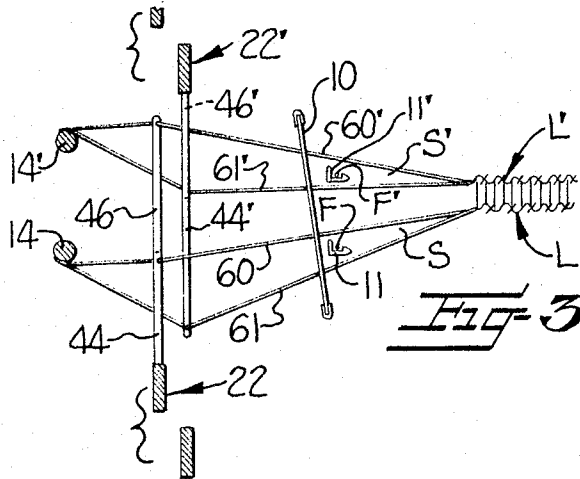

Fig-3

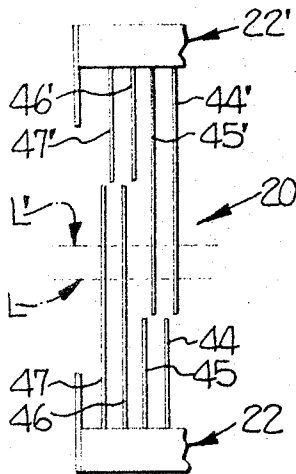

Fig-4A

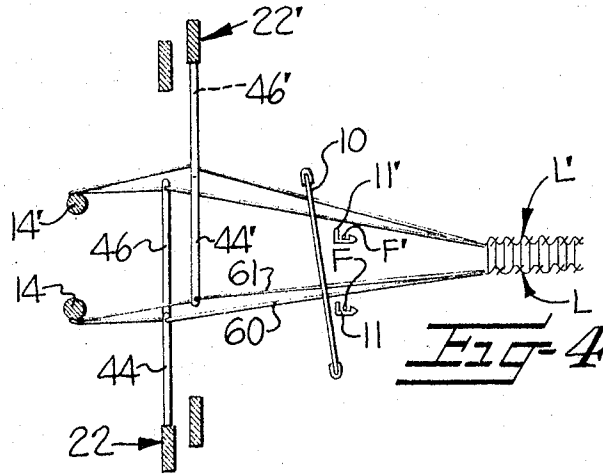

Fig-4

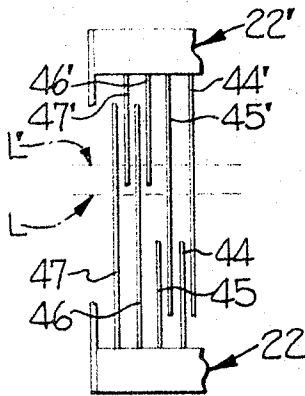

Fig-5A

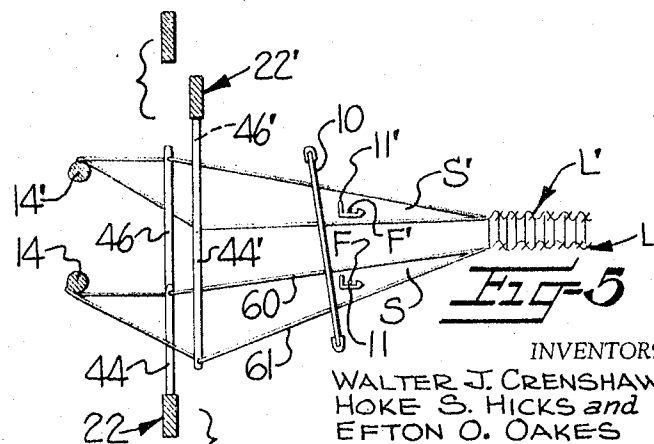

Fig-5

INVENTORS:  
 WALTER J. CRENSHAW,  
 HOKE S. HICKS and  
 EFTON O. OAKES

BY *Carroll, Bell, Seltzer, Aick & Heard*

ATTORNEYS

SELVAGE-FORMING APPARATUS FOR DOUBLE FABRIC LOOMS

Filed Sept. 15, 1966

4 Sheets-Sheet 3

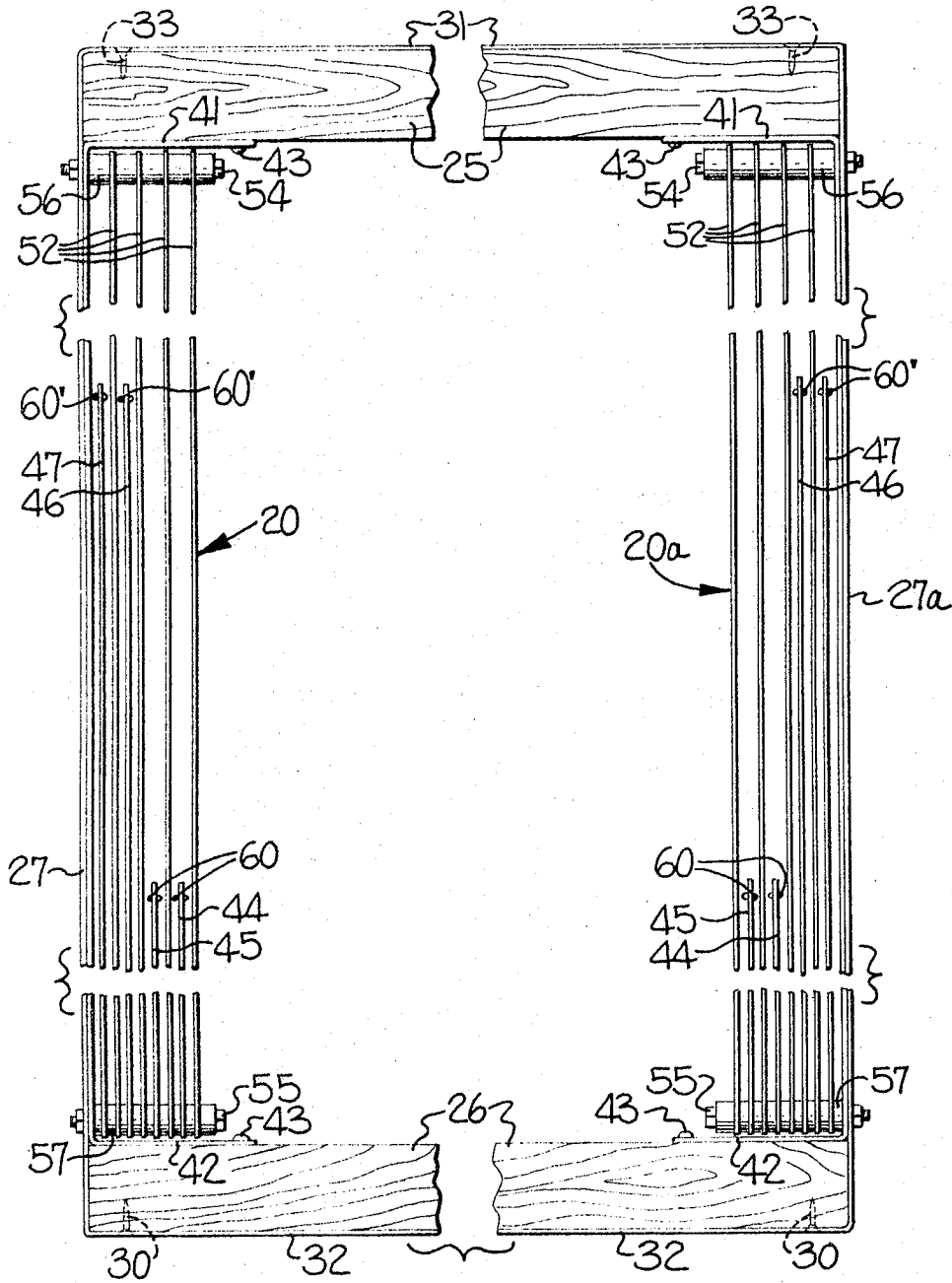

**Fig-6**

INVENTORS:

WALTER J. CRENSHAW,  
HOKE S. HICKS and  
EFTON O. OAKES

BY *Parrott, Bell, Selbye, Park & Heard*

ATTORNEYS

Aug. 26, 1969

W. J. CRENSHAW ET AL

3,463,199

SELVAGE-FORMING APPARATUS FOR DOUBLE FABRIC LOOMS

Filed Sept. 15, 1966

4 Sheets-Sheet 4

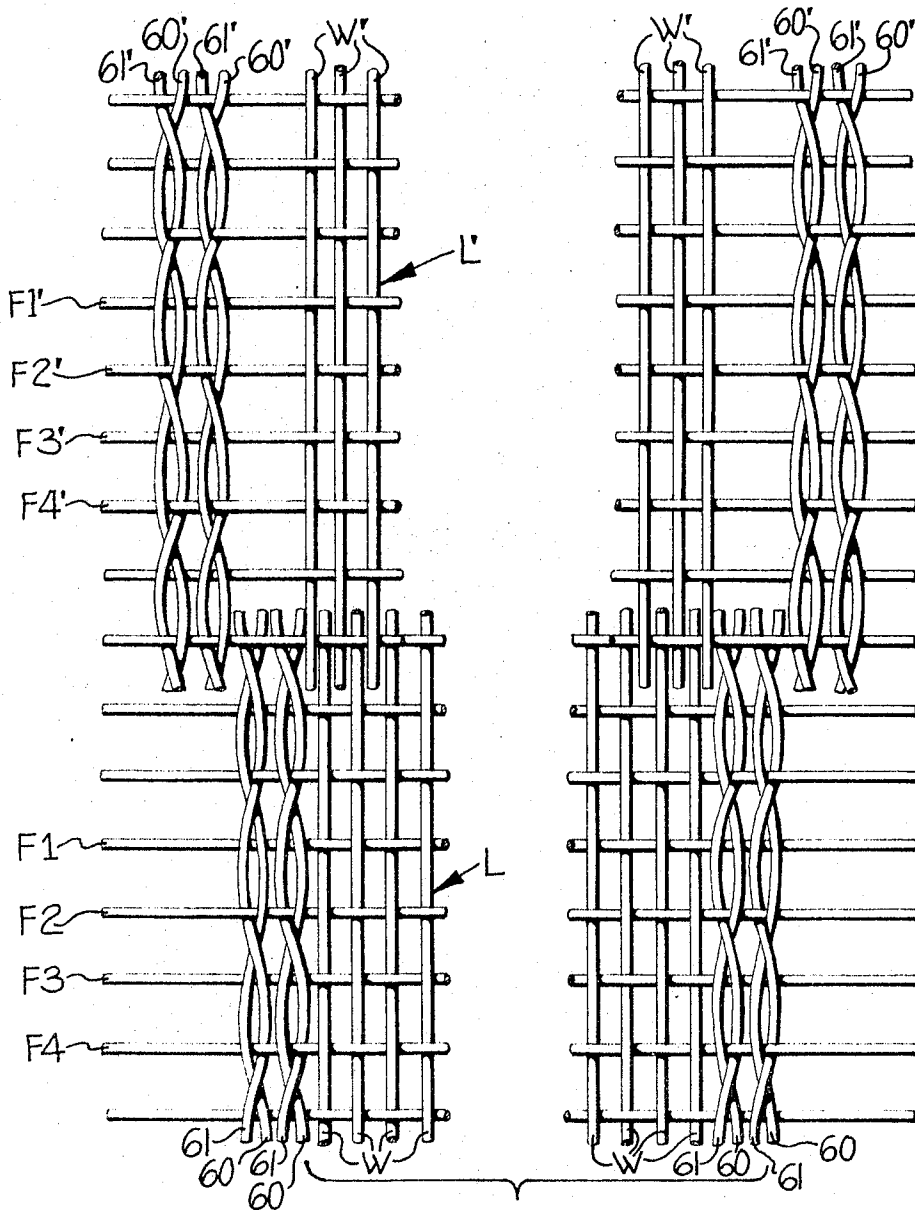

**Fig-7**

INVENTORS:

WALTER J. CRENSHAW,  
HOKE S. HICKS and  
EFTON O. OAKES

BY *Barrett, Bell, Selzer, Lark & Harsh*

ATTORNEYS

1

2

3,463,199

**SELVAGE-FORMING APPARATUS FOR DOUBLE FABRIC LOOMS**

Walter J. Crenshaw, Clemson, Hoke S. Hicks, La France, and Efton O. Oakes, Sandy Springs, S.C., assignors to Riegel Textile Corporation, a corporation of Delaware  
 Filed Sept. 15, 1966, Ser. No. 579,698  
 Int. Cl. D03c 5/04, 7/06

U.S. Cl. 139—54

2 Claims

**ABSTRACT OF THE DISCLOSURE**

Apparatus for forming selvages on corresponding edges of upper and lower fabric layers being woven in which first pairs of upper and lower needles are oppositely vertically positioned with respect to second pairs of upper and lower needles, with selvage warp yarns extending from the upper and lower needles to the respective upper and lower fabric layers. Separate carriers for the respective first and second needles are moved relatively vertically and relatively transversely so that the upper and lower needles of the first pairs alternately occupy positions adjacent one side and the other side of respective upper and lower needles of the second pairs for crossing the selvage warp yarns during certain picks of the loom.

This invention relates to a selvage-forming apparatus particularly adapted for use in forming selvages on the longitudinal edges of double layers of fabric being woven on a shuttleless loom.

As is well known, filling yarns generally are inserted in the shed of a shuttleless loom by means of reciprocating filling carriers, needles, rapiers or the like, which deliver the filling yarns from a package or other stationary yarn supply source. The picks of filling yarn are cut adjacent the edges of the fabric, thus leaving free ends of filling yarn projecting from the edges of the fabric. Various selvage-forming devices have been used satisfactorily heretofore to provide selvages on single thicknesses or layers of fabric, but such devices have not been adaptable to double fabric looms due, primarily, to space limitations imposed by the proximity of the two layers of fabric to each other.

Selvages are required on the longitudinal edges of double fabrics, especially plush cut-pile and frieze pile fabrics woven on shuttleless looms, so the edges of the fabrics will withstand any forces that may be applied thereto by tentering or other processes of finishing.

Various selvage-forming mechanisms for double fabric looms have been proposed heretofore. However, such prior art mechanisms include a large number of intricate parts which render them expensive and difficult to install and maintain.

It is therefore the primary object of this invention to provide an improved leno selvage-forming apparatus for double fabric shuttleless looms which is readily adaptable to existing looms, comprises relatively few parts, is relatively inexpensive to manufacture, install and maintain, and through which an operator may draw any parted crossing yarns with the same ease and facility with which warp yarns are drawn through conventional heddles.

In its preferred embodiment, the invention comprises at least one first pair of upper and lower substantially vertical needles mounted on a first harness frame or carrier adjacent each side of the loom, and at least one second pair of upper and lower substantially vertical needles mounted on a second harness frame or carrier adjacent the first pair of needles. The needles of the first pair project upwardly from the bottom portion of the

first carrier and the needles of the second pair project downwardly from the top portion of the second carrier. Crossing yarns extend through eyes in the free end portions of the upper and lower needles to the respective upper and lower layers of fabric, and means are provided for effecting relative reciprocable vertical movement and relative reciprocable transverse movement between the first and second carriers such that, at times, the upper and lower needles of the first pair occupy positions adjacent one side of the respective upper and lower needles of the second pair and, at other times, the upper and lower needles of the first pair occupy positions adjacent the opposite side of the respective upper and lower needles of the second pair.

Some of the objects of the invention having been stated, other objects will appear as the description proceeds when taken in connection with the accompanying drawings in which:

FIGURE 1 is a schematic longitudinal vertical sectional view through a portion of a shuttleless loom adapted for weaving double fabrics, such as plush pile fabrics, and showing a preferred embodiment of the improved selvage-forming apparatus of the present invention in association with the shed forming means and reed of the loom;

FIGURE 2 is a somewhat schematic perspective view showing portions of the needle supporting carriers of the present invention and means for effecting relative vertical and transverse movement to the carriers and the needles supported thereby, and wherein the spacing between the needles and adjacent separator bars is exaggerated for purposes of clarity;

FIGURES 3-5 are schematic views similar to FIGURE 1, omitting the conventional shed forming means, and showing successive stages in the operation of the improved selvage-forming apparatus;

FIGURES 3A, 4A and 5A are fragmentary views of the selvage-forming apparatus adjacent one side of the loom, omitting the separator bars, but showing the relative positions occupied by corresponding needles in the respective FIGURES 3, 4 and 5;

FIGURE 6 is an enlarged elevation of one of the needle supporting carriers showing, in particular, how needle units, with needles and corresponding separator bars, may be readily installed on a conventional harness frame; and

FIGURE 7 is a greatly enlarged fragmentary plan view of a double layer fabric, wherein the upper layer is shown in upwardly off-set relation to the lower layer so as to better illustrate separate leno-weave selvages as they may be interwoven with longitudinal side edges of both fabric layers utilizing the apparatus of the present invention.

Referring more specifically to the drawings, the shuttleless loom of FIGURE 1 may be of a type converted for weaving superposed plush cut pile or frieze double fabrics and such as is disclosed in our copending application Ser. No. 538,995, filed Mar. 31, 1966, to which reference is made for a more detailed disclosure thereof. The loom comprises an oscillatable reed 10 through which lower and upper sets of ground warps W, W' extend in the form of lower and upper warp sheds S, S'. Lower and upper filling inserting carriers or rapiers 11, 11' are reciprocated through sheds S, S' for inserting therethrough respective filling yarns, generally designated at F, F', to be beat up against the fells of the lower and upper superposed fabric layers L, L' being woven from the respective lower and upper sets of ground warps W, W'. Filling yarns F, F' may be directed to rapiers 11, 11' from stationary packages or supplies, not shown.

Suitable conventional shed-forming means, in the form of heddles or harnesses, 12, 12' are located rearwardly of reed 10 for forming the respective sheds S, S' of ground warps W, W'. Heddles 12, 12' may be connected to and controlled by harness cams, a jacquard mechanism, a dobby or any desired form of pattern device shown schematically at 13 in FIGURE 1. The lower and upper ground warps W, W' may be separated by suitable lease rods 14, 14' as they pass from a suitable source, not shown, to the respective heddles 12, 12'.

In the weaving of cut-pile plush fabrics, the layers L, L' of fabric are interconnected by pile yarns 15 which may be interwoven with the fabric layers L, L' in a well known manner or as disclosed in said copending application, for example. Such pile yarns 15 may be severed on the loom after the fabric layers L, L' are formed, as is well known, to separate the two layers L, L'. As is well known, in the weaving of loop pile or frieze plush fabrics, the filling yarns in the upper layer L' are interwoven with the upper set of ground warps W' in the form of narrow woven bands adjacent opposite longitudinal side edges of the fabric only, and the intervening portions of the upper filling yarns F' between the narrow woven bands extend over pile wires for supporting pile loops thereover. In such frieze fabrics, the upper filling yarns are severed intermediate their ends and, in the finishing process, the narrow woven bands of the upper fabric layer L' are pulled outwardly relative to the lower fabric layer L to remove the pile supporting filling yarns while leaving the lower fabric layer L intact with the pile loops thereon. It can be appreciated, therefore, that it is particularly important that the ends of the filling yarns are firmly secured to the narrow woven bands of the upper fabric layer L' of frieze fabrics so they will be withdrawn from the pile loops while the outward pulling force is being applied to such narrow woven bands during finishing. It is also necessary to provide suitable selvages on the bottom fabric layer L and on both layers of any double fabric so the edges of the fabric layers will withstand any forces applied thereto in subsequent finishing processes.

The selvage-forming apparatus of the present invention is particularly adapted for use with looms of the type described and comprises four needle units or assemblies 20, 20a, 20', 20a' (FIGURES 2 and 6), which are preferably of substantially the same construction with respect to each other or made from similar parts so as to be readily interchangeable or replaceable. Generally, each needle unit includes a set of at least one pair of lower and upper substantially vertical needles, and two of the needle units are positioned in substantially warpwise relationship adjacent each side of the loom; i.e., adjacent the longitudinal plane of each longitudinal edge of the double fabric L, L'. The lower and upper needles of one needle unit at each side of the loom are oppositely vertically positioned with respect to the lower and upper needles of the adjacent needle unit, as will be later explained.

As shown in FIGURES 2 and 6, needle units 20, 20a are supported by a rear harness frame or needle carrier 22, and needle units 20', 20a' are supported by a front harness frame or needle carrier 22'. Both needle carriers are shown positioned rearwardly of and adjacent the conventional shed-forming heddles 12, 12' in FIGURE 1. Although needle carrier 22 is shown rearwardly of needle carrier 22', the positions of the needle carriers 22, 22' may be reversed, if desired. Also, either or both needle carriers 22, 22' may be disposed in front of or between the conventional heddles 12, 12', as desired. Although needle carriers 22, 22' are devoid of conventional heddles and heddle-supporting bars, they may be in the form of conventional harness frames in other respects.

Needle carrier 22' may be of like or similar construction to needle carrier 22. Therefore, only the rear needle carrier 22 will be described in detail with reference to

FIGURE 6. Needle carrier 22 is in the form of a thin, substantially rectangular frame and comprises spaced top and bottom rails 25, 26 which may be made from wood and are interconnected by opposed transversely spaced metal side rails 27, 27a. Side rails 27, 27a may be interconnected by metal strip portions 31, 32 engaging the distal edges of top and bottom rails 25, 26 and secured thereto as by screws 33.

Each rear needle unit 20, 20a comprises an outer upright frame member 40 (FIGURE 6) provided with inwardly laterally projecting upper and lower arms 41, 42 suitably secured to the proximal edges of top and bottom rails 25, 26, as by screws 43. The outer surfaces of the frame members 40 of needle units 20, 20a may abut the inner surfaces of the respective side rails 27, 27a.

Each rear needle unit 20, 20a, as shown, comprises two lower needles 44, 45 and two upper needles 46, 47, all of which extend upwardly from adjacent bottom rail 26 of rear needle carrier 22 and whose free upper ends terminate substantial distances below top rail 25. The free end portion of each needle 44-47 is provided with a selvage yarn-receiving guide eye 50 therethrough. The upper needles 46, 47 are substantially longer than the lower needles 44, 45 of the particular carrier 22, but are substantially shorter than frame members 40 and separator bars 52 to be later described. The term "upper needles" is used herein to define those needles whose free ends and eyes are located on a higher level than the free ends and eyes of needles defined as "lower needles", without regard to needle lengths or whether they extend upwardly from the lower portion of the needle carrier or downwardly from the upper portion of the needle carrier.

The needles 44-47 of each rear needle unit 20, 20a extend vertically within separate vertically extending channels defined between a plurality of vertically extending, laterally spaced separator bars 52 whose upper and lower ends are positioned adjacent the respective top and bottom rails 25, 26 of rear needle carrier 22 (FIGURE 6). The outermost bar 52 cooperates with the corresponding frame member 40 of each rear needle unit 20, 20a to define the channel within which the outer upper needle 47 is positioned. The separator bars 52 and frame member 40 of each rear needle unit 20, 20a form barriers between adjacent needles to minimize unintentional inter-entanglement of adjacent selvage warp yarns, which extend through the needles, during relative movement between needle carriers 22, 22'. The upper and lower ends of separator bars 52 may be secured to frame member 40 by means of respective upper and lower bolts 54, 55 which extend through separator bars 52, the upright frame member 40, and the corresponding side rail of carrier 22.

Bolts 54, 55 have respective spacing collars or sleeves 56, 57 thereon which serve to maintain the upper and lower ends of separator bars 52 and the corresponding frame member 40, in proper, substantially equally spaced relationship. The lower ends of needles 44-47 are loosely penetrated by bolt 55 and maintained in the desired spaced relationship from the adjacent frame member 40 and the separator bars 52 by the collars 57. Thus, bolts 54, 55 and collars 56, 57 serve as means maintaining the frame member 40, bars 52 and needles 44-47 of each unit 20, 20a in fixed, transversely spaced and substantially parallel relationship.

The lower needles 44, 45 of rear needle units 20, 20a have their free upper ends and the corresponding eyes 50 thereof positioned on a level such as to direct respective lower-selvage primary crossing warp yarns or binder warp yarns 60 from a suitable source, not shown, and from beneath the lower lease rod 14 (FIGURE 1) to the fell of lower fabric layer L. Conveniently, the upper ends of lower needles 44, 45 of carrier 22 may be positioned somewhat below the level of lower fabric layer L so the

plane of the lower-selvage binder warp yarns 60 may correspond substantially with the plane of the upper sheet of ground warps W of lower warp shed S.

The upper needles 46, 47 and corresponding eyes 50 thereof are disposed on a level which is preferably above the level of upper fabric layer L' (FIGURE 1) and such as to direct respective upper-selvage primary crossing warp yarns or binder warp yarns 60' from a suitable source and from over the upper lease rod 14' of FIGURE 1 through the reed 10 and to the fell of upper fabric layer L'. The upper ends of upper rear needles 46, 47 may be located so the plane of the upper-selvage binder warp yarns 60' corresponds substantially with the plane of the upper sheet of ground warps W' of upper warp shed S'.

The front needle units 20', 20a' (FIGURE 2) are similar to the rear needle units 20, 20a (FIGURE 6) with the important exception that the needles of front needle units 20', 20a' extend downwardly from adjacent the upper portion of front needle carrier 22' so they are vertically oppositely positioned with respect to needles 44-47 of rear needle units 20, 20a. Therefore, although front needle carrier 22' and needle units 20', 20a' are only shown schematically to better illustrate the needles between the separator bars in FIGURE 2, those parts of front needle carrier 22' and its needle units 20', 20a' which are similar to corresponding parts of carrier 22 and needle units 20, 20a will bear the same reference characters with the prime notation added, where applicable, in order to avoid repetitive description.

In the illustrated embodiment of the invention, rear needle carrier 22 moves only transversely in a reciprocatory manner during operation of the loom, and front carrier 22' moves only vertically in a reciprocatory manner. When front needle carrier 22' occupies the lowered position shown in FIGURES 1, 3, 5, 3A and 5A, lower-selvage secondary crossing warp yarns or braiding warp yarns 61, which extend through the eyes 50' of the lower needles 44', 45' of each front needle unit 20', 20a' and to the fell of lower fabric layer L, are disposed in a plane corresponding substantially with the plane of the bottom sheet of ground warps W of lower warp shed S. At the same time, upper-selvage secondary crossing warp yarns or braiding warp yarns 61' extend through the eyes 50' of the respective upper needles 46', 47' of each front needle unit 20', 20a' and to the fell of the upper fabric layer L' (FIGURE 1) in such a manner that they are disposed in substantially the same plane as the plane of the bottom sheet of ground warps W' of the upper warp shed S'. The lower-selvage braiding warp yarns 61 may pass from a suitable source, not shown, beneath lease rod 14 in their course to lower needles 44', 45' of front needle units 20', 20a', and upper-selvage braiding warp yarns 61' may pass over lease rod 14' in their course from a suitable source to the eyes 50' of upper needles 46', 47' of front needle units 20', 20a'.

Means are provided for imparting transverse reciprocatory movement to rear needle carrier 22 and for imparting substantially vertical reciprocatory movement to front needle carrier 22' in such timed relationship as to weave bottom and top leno selvages in the form of leno chains at opposite longitudinal or warpwise side edges of the lower and upper fabric layers L, L' from the respective groups of lower-selvage crossing warp yarns 60, 61 and upper-selvage crossing warp yarns 60', 61' as shown in FIGURE 7. Since the lower needles 44, 45 and 44', 45' of the respective carriers 22, 22' are spaced inwardly with respect to the upper needles 46, 47 and 46', 47' of the respective carriers 22, 22', it will be observed in FIGURE 7 that the leno selvege chains at each side of the bottom fabric layer L are formed inwardly of the leno selvege chains formed at each longitudinal side edge of the upper fabric layer L'. This is due to the fact that both lower needles of each needle unit 20, 20a, 20', 20a' are disposed inwardly of the corresponding pairs of upper

needles. However, it is apparent that the leno chains formed from the respective pairs of crossing warps 60, 61 and 60', 61' at each side of the double fabric L, L' may be reversed as to their positions shown in FIGURE 7 or the leno chains of the lower fabric layer L may alternate with respect to the leno chains of the upper fabric layer L' by making appropriate changes in the relative positions of the upper and lower needles of the needle units 20, 20a, 20', 20a'.

The portions of fabric layers L, L' shown in FIGURE 7 are displaced warpwise of each other for descriptive purposes only, it being understood that the upper layer L' is actually superimposed over the lower layer L.

During the weaving of the leno selvages, the rear needle carrier 22 is shifted transversely in one direction from a given position to another position substantially upon every four-pick leno-weave selvege warp-crossing cycle of the loom, and the rear needle carrier 22 is shifted in the opposite direction from said other position to said given position substantially upon the second pick of the loom in each selvege warp-crossing cycle. The transverse motion of rear needle carrier 22 is effected by an eccentric lateral shifting cam 70 fixed on a shaft 71 (FIGURE 2) suitably driven by the loom to rotate one revolution with every four picks of the loom. Shaft 71 may correspond to shaft 83 shown in FIGURE 5 of said copending application Ser. No. 538,995.

Cam 70 is engaged by a follower arm 72 whose lower end is pivotally connected to a link 73 which is, in turn, pivotally connected to the loom frame 74, as at 75. The upper portion of follower arm 72 above cam 70 is pivotally connected to an arm or link 76 which extends inwardly and is suitably secured to the side rail 27 of rear needle carrier 22.

Needle carrier 22 may be suitably guided, as by being suspended from the usual loom arch, not shown, so that rear needle carrier 22 is moved transversely by rotation of cam 70 in engagement with follower arm 72. A spring 77 extends between the upper end of follower arm 72 and the loom frame 74 to normally urge needle carrier 22 to the left in FIGURE 2 and to maintain follower arm 72 in engagement with the periphery of cam 70.

Front needle carrier 22' may be guided for vertical movement relative to rear needle carrier 22 and relative to the loom frame 74 by any suitable means, not shown. Means are provided to impart vertical movement to front needle carrier 22' so that its needles occupy a lowered position such as that shown in FIGURES 1, 3, 5, 3A and 5A during the insertion of alternate filling yarns by rapiers 11, 11' and so that the lower ends of the lower and upper needles of front needle carrier 22' occupy a position immediately above the level of and clear of the upper ends of the respective lower and upper needles of rear needle carrier 22 during the insertion of intervening filling yarns through the sheds S, S' by rapiers 11, 11' (see FIGURES 4 and 4A). To this end opposed ends of the lower portion of front needle carrier 22' have dependent follower arms 81 suitably secured thereto. The lower end of each follower arm 81 has a suitable follower 82 thereon which bears against the periphery of a corresponding eccentric needle carrier lift cam 83 fixed on a transverse shaft 84. Shaft 84 is suitably driven by the loom in timed relation to rotation of cam 70 so as to rotate one revolution with every two picks in the operation of the loom, as is the case with respect to the harness motion cams of some conventional looms. In other words, cam 83 rotates two revolutions with each revolution in rotation of cam 70 and thus rotates two revolutions during each warp-crossing cycle occurring during every four picks in the operation of the loom. Suitable springs 85 are connected to opposed side rails 27', 27a' of front needle carrier 22' and have their lower ends connected to fixed parts of the loom frame 74 for maintaining each follower 82 in engagement with the corresponding eccentric lift cam 83.

## METHOD OF OPERATION

For the purpose of description, at the start of each selvage warp-crossing cycle in the operation of the loom, it may be assumed that follower arm 72 (FIGURE 2) is in engagement with the high portion or lobe of shifting cam 70 and that follower 82 is in engagement with the high portion or lobe of lift cam 83 so that the central portion of rear needle carrier 22 occupies a position shifted to the right of the median central plane of front needle carrier 22' when viewed looking from the rear of the loom toward the reed; i.e., when looking from left to right in FIGURES 1, 3, 4 and 5. At this instant, it follows that the braiding warp yarns 61, 61' would occupy positions above the respective binder warp yarns 60, 60', substantially as shown in FIGURE 4. However, the lower and upper needles 44', 45' and 46', 47' of front needle carrier 22' would occupy positions to the left of the vertical planes of the respective needles 44, 45, 46, 47 of rear needle carrier 22 in FIGURE 4A. With the needle carriers 22, 22' occupying the positions just described, the rapiers 11, 11' then insert respective filling yarns F1, F1' (FIGURE 7) through the sheds S, S' (FIGURE 1) formed of the respective ground warp yarns W, W' and beneath the respective pairs of binder and braiding warp yarns 60, 61 and 60', 61'.

The rear needle carrier 22 then remains in the latter position as the low surface of cam 83 (FIGURE 2) moves into engagement with follower 82 and permits front needle carrier 22' to move downwardly to the lowered position shown in FIGURES 1, 3 and 3A. In so doing, binder warp yarns 60, 60' would remain in their respective raised positions while braiding warp yarns 61, 61' would be lowered past the left-hand sides of the respective binder warp yarns 60, 60' as the free ends of the lower and upper needles 44'-47' of front needle carrier 22' move downwardly substantially below the free upper ends of, and to the left of, the respective lower and upper needles 44-47 of rear needle carrier 22 substantially as shown in FIGURE 3A. Thereupon, a second pick of the loom occurs during which rapiers 11, 11' insert respective filling yarns F2, F2' (FIGURE 7) through the respective warp sheds S and S' and between the respective lower-selvage and upper-selvage binder and braiding warp yarns 60, 61 and 60', 61' (see FIGURE 3). The front needle carrier 22' then returns to the raised position heretofore described (FIGURES 4 and 4A) and another pick of the loom occurs in which the rapiers 11, 11' insert respective filling yarns F3, F3' (FIGURE 7) through the warp sheds S, S' and beneath the respective binder and braiding warp yarns 60, 61 and 60', 61'. While the front needle carrier 22' occupies the raised position just described, the low surface of cam 70 moves into engagement with follower arm 72 (FIGURE 2) so that rear needle carrier 22 is shifted to the left relative to carrier 22' as shown in FIGURE 4A. Thereupon, the low surface of cam 83 again moves into engagement with follower 82 so that lower and upper needles 44', 45' and 46', 47' of front needle carrier 22' move downwardly to the lowered position shown in FIGURES 5 and 5A, during which the lower ends of the latter needles move downwardly past the right-hand sides of the respective needles 44-47 of rear needle carrier 22 in FIGURE 5A. Thus, the braiding warp yarns 61, 61' are moved downwardly past the right-hand sides of the respective lower and upper needles 44, 45 and 46, 47 of rear needle carrier 22, thus crossing the braiding warp yarns 61, 61' over and then moving them below the level of the respective binder warp yarns 60, 60'.

Thereupon, another pick of the loom occurs, during which the rapier 11, 11' insert respective filling yarns F4, F4' through the respective warp sheds S, S' and between the respective pairs of selvage warp yarns 60, 61 and 60', 61'.

Lifter cam 83 then raises front needle carrier 22' to return needles 44'-47' to positions above the levels of the upper ends of respective needles 44-47, then the shifting

cam 70 moves carrier 22 and rear needles 44-47 to the left in FIGURE 3A, and another pair of lower and upper filling yarns is inserted through warp sheds S, S' to start another warp-crossing cycle.

From the foregoing description, it is apparent that the movements of needle carriers 22, 22' may be transposed; i.e., rear needles 44-47 may be moved vertically so their upper ends reciprocate between positions above and below the levels of the respective needles 44'-47', and front needles 44'-47' may be reciprocated transversely from one side to the other side of the respective rear needles 44-47. Further, as heretofore stated, the relative positions of needle carriers 22, 22' may be reversed, and either or both needle carriers may be located in front of or between heddles 12, 12', as desired.

In the drawings and specification there has been set forth a preferred embodiment of the invention and, although specific terms are employed, they are used in a generic and descriptive sense only and not for purposes of limitation, the scope of the invention being defined in the claims.

We claim:

1. Apparatus for forming a leno selvage on corresponding edges of superposed upper and lower layers of fabric being woven on a loom having a reed, and shed-forming means rearwardly of the reed for forming separate upper and lower warp sheds of ground warps extending through the reed to the fells of the respective upper and lower fabric layers; said apparatus comprising first and second substantially upright and substantially rectangular harness frames disposed in warpwise relationship rearwardly of the reed and extending throughout the width of the fabric layers being woven, opposing side portions of said frames adjacent opposing side edges of the fabric layers having respective sets of substantially upright needles mounted therein and wherein each set of needles includes at least one first pair of upper and lower needles carried by and extending upwardly from a lower portion of said first frame, and at least one second pair of upper and lower needles carried by and extending downwardly from an upper portion of said second frame, each needle having a free end provided with an eye for receiving a selvage warp yarn to be crossed and wherein the selvage warp yarns extend from the upper and lower needles to the respective upper and lower fabric layers, and means operatively connected to said harness frames for imparting transverse movement only to said first frame and for imparting vertical movement only to said second frame such that the second pair of needles adjacent each side of said second frame move vertically between a position above the free upper ends of the respective needles of the first pair and a position substantially below the free upper ends of the respective needles of the first pair and such that, at times, the upper and lower needles of the first pair adjacent each side of said first frame occupy positions adjacent one side of the respective upper and lower needles of the second pair and, at other times, the upper and lower needles of the first pair occupy positions adjacent the opposite side of the respective upper and lower needles of the second pair.

2. Apparatus according to claim 1, wherein said means operatively connected to said harness frames comprises first and second rotary cams positioned adjacent one side of said first frame and below said second frame, respectively, a substantially vertically disposed follower arm engaging said first cam, means pivotally connecting a portion of said follower arm to said first frame, means pivotally connecting another portion of said follower arm to a fixed part of the loom, said follower arm engaging said first cam at a point spaced between the two pivotal connection means of said follower arm, spring means urging said first frame and said follower arm toward said first cam, a follower carried by a lower portion of said second frame and engaging said second cam, spring means urging said second frame and said follower toward said second



9

cam, and the relationship of said first and second cams being such that a transverse movement is imparted to said first frame each time said second frame is moved upwardly by said second cam and positions said second pair of needles above the free upper ends of the respective upper and lower needles of said first pair. 5

**References Cited**

**UNITED STATES PATENTS**

585,576 6/1897 Crutchlow ----- 139—54 10

10

1,568,020 12/1925 Griffith ----- 139—53  
 1,762,717 6/1930 Herring ----- 139—53  
 1,943,662 1/1934 Emery et al. ----- 139—54  
 2,253,202 8/1941 Arnold ----- 139—115  
 3,376,899 4/1968 Quintana ----- 139—54

**FOREIGN PATENTS**

1,465,088 11/1966 France.

HENRY S. JAUDON, Primary Examiner

UNITED STATES PATENT OFFICE  
CERTIFICATE OF CORRECTION

Patent No. 3,463,199 Dated August 26, 1969

Inventor(s) Walter J. Crenshaw, Hoke S. Hicks and Efton O. Oake

It is certified that error appears in the above-identified patent and that said Letters Patent are hereby corrected as shown below:

Column 9, line 9 (under "References Cited") "585,576" should read --584,576--.

SIGNED AND  
SEALED

DEC 2 - 1969

**(SEAL)**

**Attest:**

**Edward M. Fletcher, Jr.**  
**Attesting Officer**

**WILLIAM E. SCHUYLER, JR.**  
**Commissioner of Patents**

L