

(19) World Intellectual Property Organization  
International Bureau



(43) International Publication Date  
22 August 2002 (22.08.2002)

PCT

(10) International Publication Number  
WO 02/065005 A1

- (51) International Patent Classification<sup>7</sup>: F16K 31/02
- (21) International Application Number: PCT/US01/50490
- (22) International Filing Date: 23 October 2001 (23.10.2001)
- (25) Filing Language: English
- (26) Publication Language: English
- (30) Priority Data:  
60/246,469 6 November 2000 (06.11.2000) US
- (71) Applicant: CALIFORNIA INSTITUTE OF TECHNOLOGY [US/US]; 1200 East California Boulevard, Pasadena, CA 91115 (US).
- (72) Inventors: DRIGGS, Scott, B.; 1235 Whitehall Place, Bossier City, LA 71112 (US). ENZELBERGER,
- (54) Title: ELECTROSTATIC VALVES FOR MICROFLUIDIC DEVICES
- (57) Abstract: Valve structures (100) formed in elastomer material (108) are electrostatically actuated by applying voltage to a flexible, electrically conductive wire pattern. An actuation force generated between the patterned wire structure and an electrode (112) result in closure of a flow channel (102) formed in elastomer material (108) underlying the wire. In one embodiment of a valve structure (100) in accordance with the present invention, the wire structure is patterned by lithography and etching of a copper/polyimide laminate, with an underlying gold plate (114) positioned on the opposite side of the flow channel (102) serving as an electrode (112). In an alternative embodiment (400), application of an actuation force between the first (418) and second (428) patterned strips closes the control channel (422) and an associated flow channel (406) underlying the control channel (422).
- (74) Agents: TOBIN, Kent, J. et al.; Townsend and Townsend and Crew LLP, Two Embarcadero Center, 8th Floor, San Francisco, CA 94111-3834 (US).
- (81) Designated States (national): AE, AG, AL, AM, AT, AU, AZ, BA, BB, BG, BR, BY, BZ, CA, CH, CN, CO, CR, CU, CZ, DE, DK, DM, DZ, EC, EE, ES, FI, GB, GD, GE, GH, GM, HR, HU, ID, IL, IN, IS, JP, KE, KG, KP, KR, KZ, LC, LK, LR, LS, LT, LU, LV, MA, MD, MG, MK, MN, MW, MX, MZ, NO, NZ, PH, PL, PT, RO, RU, SD, SE, SG, SI, SK, SL, TJ, TM, TR, TT, TZ, UA, UG, UZ, VN, YU, ZA, ZW.
- (84) Designated States (regional): ARIPO patent (GH, GM, KE, LS, MW, MZ, SD, SL, SZ, TZ, UG, ZW), Eurasian

[Continued on next page]

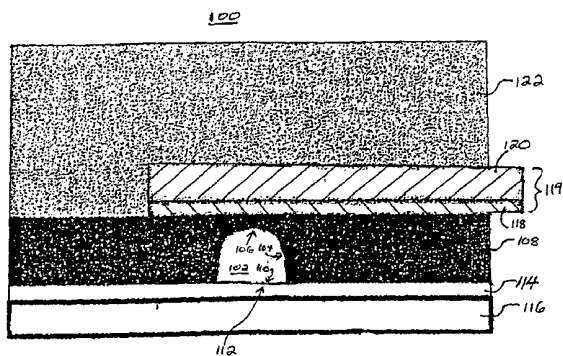

A

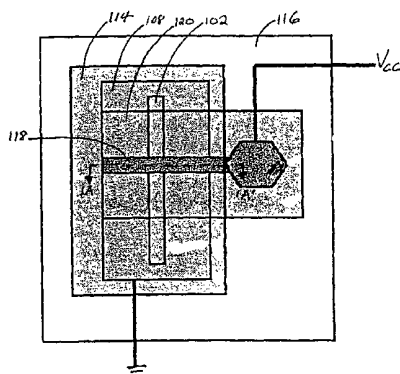

B



WO 02/065005 A1



patent (AM, AZ, BY, KG, KZ, MD, RU, TJ, TM), European patent (AT, BE, CH, CY, DE, DK, ES, FI, FR, GB, GR, IE, IT, LU, MC, NL, PT, SE, TR), OAPI patent (BF, BJ, CF, CG, CI, CM, GA, GN, GQ, GW, ML, MR, NE, SN, TD, TG).

**Published:**

— with international search report

— before the expiration of the time limit for amending the claims and to be republished in the event of receipt of amendments

*For two-letter codes and other abbreviations, refer to the "Guidance Notes on Codes and Abbreviations" appearing at the beginning of each regular issue of the PCT Gazette.*

## **ELECTROSTATIC VALVES FOR MICROFLUIDIC DEVICES**

### **5 CROSS-REFERENCE TO RELATED APPLICATION**

This nonprovisional patent application claims priority from provisional patent application no. 60/246,469, filed November 6, 2000. The text of this provisional patent application is hereby incorporated by reference.

### **10 STATEMENT AS TO RIGHTS TO INVENTIONS MADE UNDER FEDERALLY SPONSORED RESEARCH AND DEVELOPMENT**

Work described herein has been supported, in part, by Air Force Research Organization grant DAAD 19-00-1-0392. The United States Government may therefore have certain rights in the invention.

### **15 BACKGROUND OF THE INVENTION**

Pumps and valves for transporting and manipulating liquids in microfluidic devices are essential for developing lab on a chip technology. Various approaches to designing micro-fluidic pumps and valves have been attempted. However, each of these conventional approaches suffers from its own limitations.

The two most common methods of producing microelectromechanical (MEMS) structures such as pumps and valves are silicon-based bulk micro-machining (which is a subtractive fabrication method whereby single crystal silicon is lithographically patterned and then etched to form three-dimensional structures), and surface micro-machining (which is an additive method where layers of semiconductor-type materials such as polysilicon, silicon nitride, silicon dioxide, and various metals are sequentially added and patterned to make three-dimensional structures).

A limitation of the first approach of silicon-based micro-machining is that the stiffness of the semiconductor materials used may necessitate high actuation forces, which in turn result in large and complex designs. In fact, both bulk and surface micro-machining methods are limited by the stiffness of the materials used. In addition,

adhesion between various layers of the fabricated device is also a problem. For example, in bulk micro-machining, wafer bonding techniques must be employed to create multilayer structures. On the other hand, when surface micro-machining, thermal stresses between the various layers of the device limits the total device thickness, often to  
5 approximately 20  $\mu\text{m}$ . Using either of the above methods, clean room fabrication and careful quality control are required.

Pressure driven valves for devices made out of soft polymers (e.g. PDMS) are described in United States Nonprovisional Patent Application No. 09/605,520, incorporated herein by reference for all purposes herein.

10 From the above, it is seen that utilization of structures and methods for efficient and effective movement of fluids are highly desired.

#### SUMMARY OF THE INVENTION

Embodiments of the present invention relate to electrostatically actuated  
15 valve structures formed in elastomeric material. Specifically, a flow channel present in an elastomer block may be opened or closed by the application of a potential difference. In one embodiment of a valve structure in accordance with the present invention, a flexible conductive wire structure is patterned by lithography and etching of a copper/polyimide laminate. The patterned copper wire is positioned on top of elastomer  
20 material making up a ceiling of an underlying flow channel. A gold electrode forms the floor of the flow channel. Application of a potential difference between the wire and the underlying gold electrode drives the flexible wire and the elastomer ceiling of the flow channel down into the flow channel, obstructing the flow channel. Removal of the  
25 potential difference causes the wire/elastomer structure to relax back into its initial position out of the flow channel, opening the valve.

In an alternative valve structure in accordance with the present invention, flexible patterns of aluminum wire are formed from strips of aluminum/Mylar laminate layers that are cut out from a larger sheet of laminate and then positioned on opposite sides of a control channel, the control channel overlying and connected to the flow  
30 channel. Application of a potential difference drives the wires together, closes the control channel, and also brings together the walls of the underlying flow channel to close the valve.

These and other embodiments of the present invention, as well as its advantages and features are described in more detail in conjunction with the text below and the attached Figures.

5 BRIEF DESCRIPTION OF THE DRAWINGS

Figure 1A shows a simplified cross-sectional view of one embodiment of an electrostatically-actuated valve structure in accordance with the present invention. Figure 1B shows a simplified plan view of the electrostatically actuated valve structure of Figure 1A.

10 Figure 2A shows a microscope plan view of a valve structure in a nonactuated state having a channel with of 100  $\mu\text{m}$  underlying an orthogonally-positioned copper wire having a width of 200  $\mu\text{m}$ . Figure 2B shows a microscope plan view of the valve structure of Figure 2A in an actuated state.

Figure 3 shows a cross-sectional view of an embodiment of a device  
15 containing multiple addressable valves in accordance with the present invention.

Figure 4A shows a simplified cross-sectional view of a valve structure in accordance with a second alternative embodiment of the present invention, in a non-actuated state. Figure 4B shows a simplified cross-sectional view of the valve structure of Figure 4A in an actuated state. Figure 4C shows a plan view of the valve structure of  
20 Figures 4A and 4B.

DESCRIPTION OF THE SPECIFIC EMBODIMENTS

The subject matter of the present application is related to U.S. nonprovisional patent application number 09/605,520, filed June 27, 2000. The content  
25 of this nonprovisional patent application is incorporated by reference herein.

As described above, it is desirable to find alternative valve structures and methods of their activation for use in various microfluidic applications, for example implementable high density microfluidic devices. Embodiments of the present invention therefore relate to methods and structures for closing channels in elastomeric materials by  
30 electrostatic action utilizing flexible conductive materials (e.g. copper/polyimide or aluminum/Mylar laminates) that can readily be patterned for a variety of applications.

## I. First Embodiment of a Valve Structure in Accordance with the Present Invention

### A. Sources of Materials

RTV 615 polydimethylsulfoxide (PDMS) was obtained from General Electric. Pyralux LF 9110 copper/polyimide laminate was obtained from DuPont.  
5 Photoresist 5740 and Developer CD 20 were obtained from Shipley Microelectronics. Trimethylchlorosilane (TMCS) and FeCl<sub>3</sub> were obtained from Sigma. Hexamethyldisilazine (HMDS) was obtained from ShinEtsuMicrosi of Phoenix, Arizona.

### B. Fabrication of mold

10 A silicon wafer was exposed to HMDS, and then Photoresist 5740 was spun upon a silicon wafer at 2000 rpm for 60 sec. The photoresist/wafer combination was then baked at 95°C for 60 min. The coated wafer was exposed to UV light through a mask for 2.3 min. to create exposed photoresist regions having widths varying between 30-250 μm. Development of the photoresist with 20% CD20 resulted in removal of  
15 unexposed photoresist. The wafer and patterned exposed photoresist features formed thereon were hard baked at 130°C for 30 min. on a hot plate, causing reflow of the photoresist and resulting in rounding of the raised photoresist features.

### C. Fabrication of flow channel-containing structure from the mold

20 The silicon wafer bearing the raised, rounded photoresist features was next utilized as a mold to fabricate the elastomeric channel-containing structure. The raised photoresist features were treated with TMCS in the gas phase. RTV 615 PDMS was mixed at 30:1 (component A : component B) and then spun onto the mold at 2000 rpm for 45 sec., resulting in formation of a PDMS layer having a thickness of around 20 μm over  
25 the mold. This PDMS layer was then hardened by baking for 90 min. at 85°C.

### D. Fabrication of flexible electrically-conductive wires

A sheet of Pyralux LF9110 laminate having a copper side and a polyimide side was treated with HMDS, and afterwards Photoresist 5740 was spun on to the copper  
30 side at 2000 rpm for 60 sec.

After baking at 95°C for 60 min, the photoresist on the copper side of the Pyralux laminate was exposed to light through a mask bearing the control wire pattern.

After developing for 60 sec. with 20% CD20 to remove the unexposed photoresist, the copper of the laminate exposed during development was etched with  $\text{FeCl}_3$  solution having a concentration of 1.4 g/ml. Residual developed photoresist overlying the remaining copper wires was removed using acetone to leave the patterned copper control lines lying on top of the polyimide layer of the laminate.

E. Fabrication of valve structure from channel-containing structure and flexible electrically conductive wires

The electrically conducting copper control lines were cut out from the larger laminate sheet, turned over, and then placed flat, copper side down, over the 30:1 PDMS channel-containing structure, such that at crossover points the copper wires were positioned orthogonal to the underlying flow channels. Portions of the bare polyimide layer from which copper had previously been removed were flexible and conformed over the copper wires to directly contact the surface of the 30:1 PDMS, such that few if any voids between the polyimide and 30:1 PDMS were created.

Next, 3:1 (component A : component B) PDMS was poured on top of the polyimide layer of the laminate, and the entire combined device was baked for additional 90 min. to bind the 3:1 PDMS elastomer to the polyimide. The purpose of the additional (3:1) PDMS layer was to passivate the underlying flow channel/wire structure.

The entire device was then removed from the mold and transferred to a glass slide bearing a patterned gold layer having a thickness of 5000 Å.

Figure 1A shows a simplified cross-sectional view of the resulting electrostatically-actuated valve structure. Figure 1B shows a simplified plan view of the electrostatically actuated valve structure.

Valve structure 100 includes flow channel 102 having walls 104 and arched ceiling 106 formed from 30:1 PDMS elastomer material 108. Arched ceiling 106 reflects the rounded profile of the raised features on the mold created by reflowing the photoresist material, as described above under section I.B.

Floor 110 of flow channel 102 is formed from electrode 112 that is part of gold layer 114 patterned on glass slide 116. Copper wire 118 overlies ceiling portion 106 of elastomer layer 108 and polyimide layer 120 overlies copper wire 118.

During operation of valve structure 100, a voltage is applied to copper wire 118. This voltage creates an attraction between copper wire 118 and underlying gold electrode 112, such that copper wire 118 and arched ceiling portion 106 of 30:1 PDMS elastomer 108 are driven downward into flow channel 102, closing valve structure 100. Upon cessation of application of voltage to copper wire 118, the attractive force between copper wire 118 and underlying gold electrode 112 is no longer present, and copper wire 118 and arched membrane portion 106 of 30:1 PDMS elastomer 108 relax upward out of flow channel 102, opening valve structure 100.

The response time for closing of the valve structure shown in Figures 1A-1B having a flow channel of width 100  $\mu\text{m}$  was less than 100 ms. The time for relaxation and opening of the valve structure of Figures 1A-1B was around 3 seconds following the cessation of the applied voltage. The substantially longer time required for the valve to open following actuation may be due to actuation of valves having empty air-filled flow channels. No change in the performance of the valve structure of Figures 1A-1B was observed after 100 close/open cycles.

Figure 2A shows a microscope plan view of a nonactuated valve structure having a width of flow channel 102 of width 100  $\mu\text{m}$  underlying an orthogonally-positioned copper wire 118 having a width of 200  $\mu\text{m}$ . Figure 2B shows a microscope plan view of the valve structure of Figure 2A that is actuated by applying a voltage of 1200V to copper wire 118. Figure 2B clearly shows deformation (closing) at crossover portion 102a of flow channel 102 resulting from application of a potential difference of 1200V between copper wire 118 and underlying gold electrode 112.

The valve structures in accordance with embodiments of the present invention offer a number of advantages. One advantage is the possibility of utilizing optics to determine the state of the valve. Specifically, a laser beam can be aimed at the elastomer surface at the location of the wire/channel cross-over point. By measuring the deflection of the laser beam, flexion of the copper wire and the underlying elastomer channel forming the roof of the flow channel, and hence the degree of openness of the valve structure, can be determined.

In addition to utilizing optics to detect valve position, flexion of the copper wire and underlying elastomer material as described above could also be employed to create a micromachined switching mirror. Specifically, the wire/channel cross-over point



could be formed as a reflective, micro-mirror surface that serves as a target for a light source such as a laser beam. Actuation of the valve would alter the orientation of the micro-mirror surface and change the angle of reflection of a beam aimed at the micro-mirror. Such a switching mirror would have potential applications in a variety of optical display and networking applications.

Another advantage of embodiments of valve structures in accordance with the present invention is their low price and ready integration with existing technology. Specifically, elastomer materials in which the flow channels are formed are readily available in bulk quantities. Moreover, the photoresist and photoresist development chemicals utilized to create the mold and to pattern the copper wire from the laminate sheet are widely used in conventional semiconductor processing.

Yet another important advantage of embodiments of the present invention is the ability to form operational multi-valve structures in which the electrically conducting control wires cross over one another. This is illustrated below in conjunction with Figure 3, which shows a cross-sectional view of an embodiment of a device containing multiple addressable valves in accordance with the present invention.

Multiple valve device 300 includes flow channel 302 having walls (not shown in Figure 3 cross-section) and ceiling 304 formed from 30:1 PDMS elastomer material 306. Floor 308 of flow channel 302 is formed from electrode 310 that is part of gold layer 312 patterned over glass slide 314. First copper wire 316 of the first laminate overlies flow channel 302 at first valve location 318, and first polyimide layer 320 overlies first copper wire 316.

Second copper wire 322 of the second laminate overlies first polyimide layer 320 and overlies 30:1 PDMS elastomer material 306 at second valve location 324. Second polyimide layer 326 overlies second copper wire 322 of the second laminate. 3:1 RTV PDMS 328 overlies second polyimide layer 326.

Because of the highly insulating properties of first polyimide layer 320, a voltage applied to second copper wire 322 will not affect the application of voltage to underlying first copper wire 316, and vice versa. In this manner, a multilayer structure of overlapping electrical wires may be fabricated utilizing successive layers of patterned laminate material, analogous to formation of multilayer interconnect metallization structures of integrated circuits.

## II. Second Embodiment of a Valve Structure in Accordance with the Present Invention

While embodiments of valve structures described above in connection with Figures 1A-3 utilize flexible electrical control wires fabricated from copper/polyimide laminate layers overlying the flow channel, the present invention is not limited to this particular structure. Other structures and/or materials could be utilized to control the flow liquid and gaseous materials, and still remain within the scope of the present invention.

For example, in both embodiments described above in conjunction with Figures 1A-3, an electric field is applied across the flow channel during actuation of the valve structure. However, in an electric field ions present in the flow channel may migrate to a side of the flow channel proximate to one of the charged poles (wire or electrode). This possible migration of charged species could affect the magnitude of the electrostatic force applied to the valve.

In addition, substances in the flow channel that are susceptible to electrochemical reaction (e.g. electrolysis) may undergo electrolysis during actuation due to contact with the electrode and the potential within the flow channel.

Therefore, in accordance with an alternative embodiment of the present invention, the flow channel of a valve structure is closed by application of an electrostatic force across a control channel overlying the flow channel, rather than across the flow channel itself. Closing the upper control channel in turn forces the flow channel to close. Operation and fabrication of this alternative valve structure is illustrated in detail in conjunction with Figures 4A-4C below.

### A. Sources of materials

RTV 615 PDMS was obtained from General Electric. Aluminum/Mylar laminate (10  $\mu\text{m}$ , 12 Ohm/in<sup>2</sup> was obtained from Steinerfilm, Inc. of Willfamstown, Mass. Photoresist 5740 and Developer CD 20 were obtained from Shipley Microelectronics. Trimethylchlorosilane (TMCS) was obtained from Sigma. HMDS was obtained from ShinEtsuMicrosi of Phoenix, Arizona. Silver Epoxy was obtained from Chemtronics of Kennesaw, Georgia.

B. Fabrication of first mold for flow channel-containing portion

A silicon wafer was treated with HMDS in the gas phase for 1 min. Photoresist 5740 was spun on the wafer at 2000 rpm for 60 sec. and baked for 60 min. at 90°C. After exposing with UV through a mask containing the desired pattern for 2.3 min. the Photoresist was developed using 20% Developer CD-30 to produce raised line structures of between 30 and 250  $\mu\text{m}$  in width. In order to round these photoresist features, the mold was then heated for 30 min. at 130°C on a hot plate.

10 C. Fabrication of flow channel-containing portion

30:1(component A: component B) RTV 615 was spun at 2000 rpm for 45 sec. on the first mold fabricated above after treatment with TMCS in the gas phase. The wafer was then baked for 60 minutes at 80°C.

15 2 mm wide strips of Mylar/Aluminum laminate were cut out by hand from a larger laminate sheet and then placed, Aluminum side up, on top of the 30:1 elastomer, orthogonal to the underlying flow channel. A second thin layer of 30:1 (component A: component B) RTV 615 was spun at 4000 rpm for 30 sec. over the Aluminum, and the wafer was baked again for 60 min. at 80°C.

20 D. Fabrication of control channel-containing portion

3:1 (component A: component B) RTV 615 was spun at 2000 rpm for 45 sec. on a second mold bearing a pattern of raised lines of photoresist having a width of 100  $\mu\text{m}$ . These raised lines are formed by lithography in the same manner as described above for formation of the first mold, and the raised lines occupy the space that will later serve as the control channels of the device.

25 The second wafer was then baked for 60 min. at 80° C. A second set of 2 mm wide strips of Mylar/Aluminum laminate were cut out by hand from a larger laminate sheet and placed, Aluminum side down, over the control channels. A second 3:1 (component A: component B) RTV 615 material was then poured on top of the second wafer (ca. 5 mm) and the second wafer baked again for 60 min. at 80°C.

30

#### E. Assembly of valve structure

The valve structure in accordance with an alternative embodiment of the present invention was assembled by peeling the control channel-containing portion off of the second wafer, and placing the control channel-containing portion over the flow channel-containing portion. During this step, the control channels and flow channels were oriented orthogonal to one another.

The combined structure was then baked for 1 hour at 80°C to bind the top 30:1 RTV 615 elastomer layer of the flow channel-containing portion to the first 3:1 RTV 615 elastomer material of the control channel-containing portion. The complete device was then peeled carefully from the first wafer and placed against a glass slide to enclose the flow channel. Contacts to the aluminum control strips were created utilizing silver epoxy.

Figure 4A shows a simplified cross-sectional view of a valve structure in accordance with a second alternative embodiment of the present invention, in a non-actuated state. Figure 4B shows a simplified cross-sectional view of the valve structure of Figure 4A in an actuated state. Figure 4C shows a plan view of the valve structure of Figures 4A and 4B.

Valve structure 400 includes control channel-containing portion 402 on top of flow channel-containing portion 404.

Flow channel-containing portion 404 includes flow channel 406 having walls 408 and arched ceiling 410 formed from first 30:1 RTV 615 material layer 412 that was poured over the first mold. Arched ceiling 410 reflects the rounded profile of the raised features on the first mold that were created by reflowing the photoresist material, as described above under section II.B. Floor 411 of flow channel 406 is formed from underlying glass plate 413.

First Mylar strip 414 of first laminate 416 overlies RTV 615 layer 412, and first Aluminum strip 418 overlies first Mylar strip 414. Second RTV 615 material layer 420 overlies first Aluminum strip 418.

Control channel-containing portion 402 includes control channel 422 having walls and ceiling formed from first 3:1 RTV 615 elastomer layer 424, and floor 426 made up of second 30:1 RTV 615 material layer 420 of flow channel-containing portion 404. Second aluminum strip 428 of second laminate 430 overlies 3:1 RTV 615 material layer 424, and second Mylar strip 432 of second laminate 430 overlies second

Aluminum strip 428. Second 3:1 RTV 615 material layer 434 overlies second Mylar strip 432.

5 During actuation of valve 400, a potential difference is applied across first Aluminum strip 418 and second Aluminum strip 428. The electric field generated by this potential difference creates an attractive actuation force between Aluminum strips 418 and 428. As a result, Aluminum strips 418 and 428 are drawn toward one another due to flexibility of the elastomer and the freedom of movement imparted by the intervening control channel 422.

10 Upward movement of first Aluminum strip 418 forces walls 408 of flow channel 406 to move together, closing flow channel 406.

Upon cessation of application of the potential difference across Aluminum strips 418 and 428, the attractive force between strips 418 and 428 vanishes. Strips 418 and 428 relax back to their initial positions, such that control channel 422 and flow channel 406 open.

15 By applying 1600V over the control channel, the inventors have discovered that the flow channel is significantly compressed (closed). Times for closing and opening of this alternative valve structure are currently being further investigated.

20 Given the variety of embodiments of the present invention just described, the above description and illustrations should not be taken as limiting the scope of the present invention which is defined by the appended claims.

WHAT IS CLAIMED IS:

1. A valve structure comprising:
  - an elastomeric layer defining a flow channel having walls and a ceiling;
  - a first electrode positioned on top of the elastomeric layer over the ceiling of the flow channel; and
  - a second electrode positioned beneath the flow channel, such that application of a potential difference between the first electrode and the second electrode drives the first electrode and the ceiling of the flow channel into the flow channel.
  
2. The valve of claim 1 further comprising a reflective micromirror surface positioned over the ceiling of the flow channel, a physical orientation of the reflective micromirror surface altered when the ceiling of the flow channel is driven into the flow channel.
  
3. A valve structure comprising:
  - a first elastomeric layer defining a flow channel having walls and a ceiling;
  - a first electrode positioned on top of the first elastomeric layer over the ceiling of the flow channel;
  - a second elastomeric layer positioned over the first electrode;
  - a third elastomeric layer positioned over the second elastomeric layer, the third elastomeric layer defining a control channel having walls and a ceiling, the second elastomeric layer forming a floor of the control channel; and
  - a second electrode positioned on top of the third elastomeric layer over the control channel, such that application of a potential difference between the first electrode and the second electrode drives the first electrode and the second electrode together, causing the walls of the control channel and of the underlying flow channel to be driven together.
  
4. The valve of claim 3 further comprising a reflective micromirror surface positioned over the ceiling of the flow channel, a physical orientation of the reflective micromirror surface altered when the ceiling of the flow channel is driven into the flow channel.

5. A method of fabricating an electrostatically actuated elastomeric valve structure comprising:

patterning a raised photoresist line on a semiconductor substrate;

forming an elastomer material over the raised line;

lithographically etching a conductor layer of a conductor/insulator laminate material to form a conductive line;

placing the conductive line on top of the elastomer material over the raised line; and

removing the elastomer material from the raised line and placing the elastomer material against an electrode, such that a space in the elastomer formerly occupied by the raised line comprises a flow channel.

6. The method of claim 5 further comprising forming a reflective micromirror surface over the flow channel.

7. A method of fabricating an electrostatically actuated elastomeric valve structure comprising:

forming a flow channel-containing portion by,

patterning a first raised photoresist line on a first semiconductor substrate,

forming a first elastomer material over the first raised line,

patterning a conductor layer of a first conductor/insulator laminate material to form a first conductive line,

placing the conductive line on top of the first elastomer material over the raised line, and

forming a second elastomer layer over the conductive line;

forming a control channel-containing portion by,

patterning a second raised photoresist line on a second semiconductor substrate,

forming a third elastomer material over the second raised line,

patterning a conductor layer of a second conductor/insulator laminate material to form a second conductive line, and

placing the second conductive line on top of the third elastomer material and over the raised line; and  
combining the control channel-containing portion to the flow channel-containing portion to form the valve by,

removing the third elastomer material from the second raised photoresist line, and

placing the third elastomer material on top of the second elastomer material, such that the first conductive line overlies the second conductive line separated by a control channel in a space in the third elastomer layer formerly occupied by the second raised line.

8. The method of claim 7 further comprising forming a micromirror surface over the control channel.

9. A method of electrostatically actuating an elastomeric valve structure comprising:

positioning a first electrode as a floor of a flow channel in an elastomer layer;

positioning a flexible conductive wire over a ceiling portion of the flow channel; and

applying a potential difference between the first electrode and the flexible conductive wire, such that the flexible wire and the ceiling portion of the flow channel are driven into the flow channel.

10. A method of electrostatically actuating an elastomeric valve structure comprising:

positioning a first flexible conductive wire over a ceiling portion of a flow channel formed in a first elastomeric layer;

positioning a second flexible conductive wire over a ceiling portion of a control channel formed in a second elastomeric layer integral with the first elastomeric layer;

applying a potential difference between the first flexible conductive wire and the second flexible conductive wire, such that the ceiling portion of the flow channel



and the ceiling portion of the control channel are driven into the control channel, and walls of the flow channel in the first elastomeric layer are brought together.

11. A method of changing a path of an optical beam comprising:
  - providing a reflective surface overlying a ceiling of a channel formed in an elastomer material;
  - providing a first electrode overlying the ceiling of the channel formed in the elastomer material;
  - applying an optical beam to the reflective surface;
  - creating an electrostatic force between the ceiling of the channel and a second electrode underlying the first electrode, such that the ceiling of the channel and the reflective surface are at least partially driven into the channel; and
  - again applying the optical beam to the reflective surface.

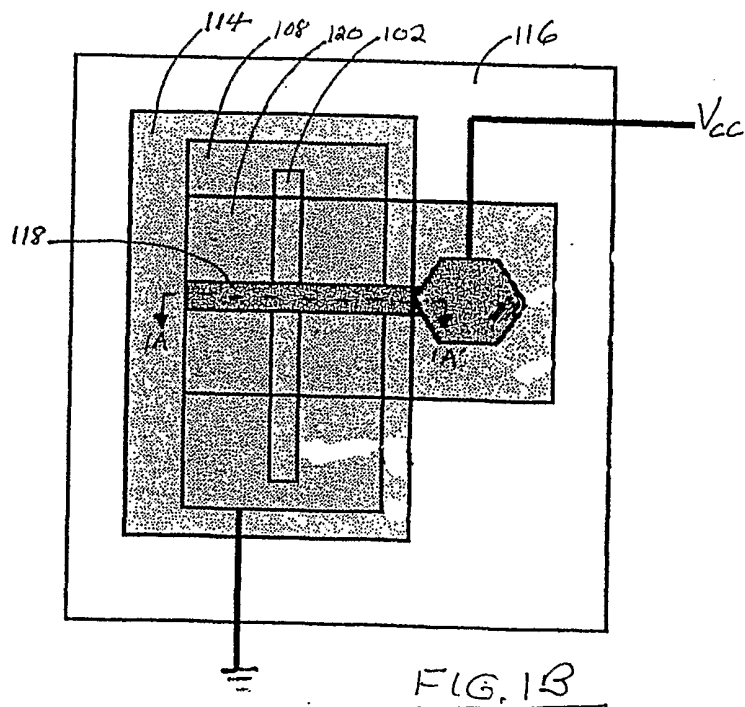
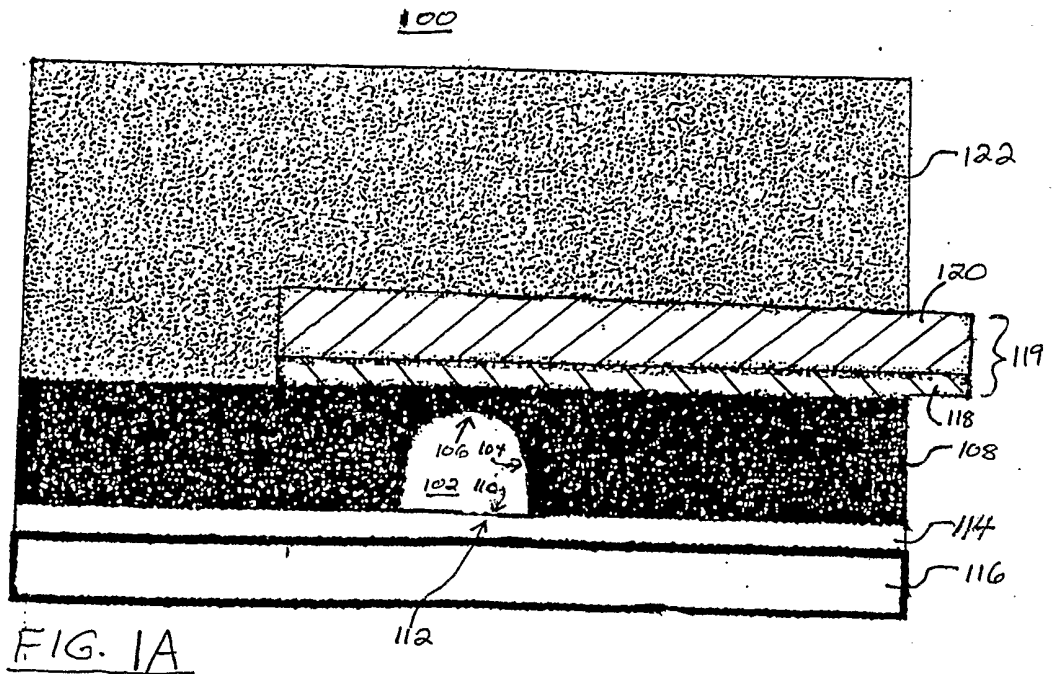

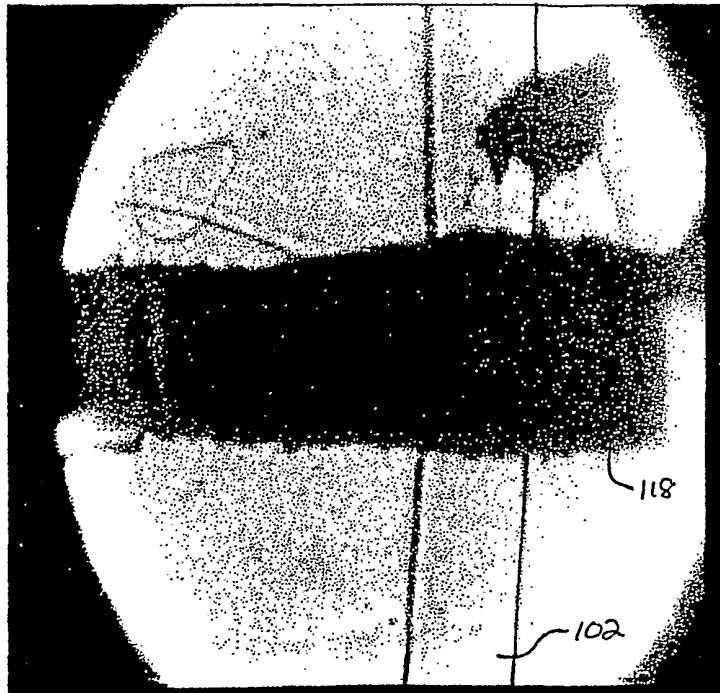

FIG. 2A

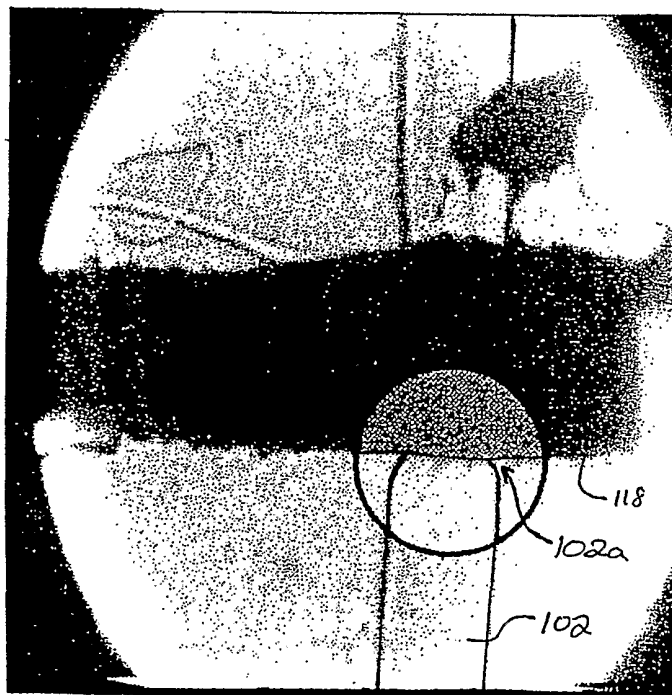

FIG. 2B

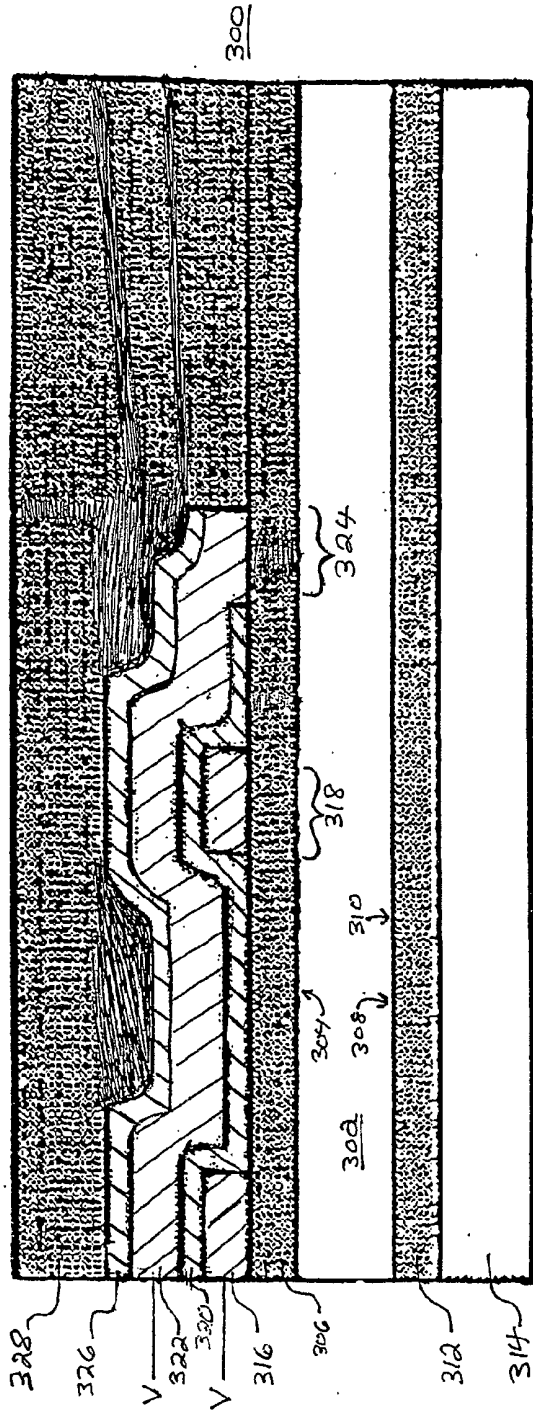

FIG. 3

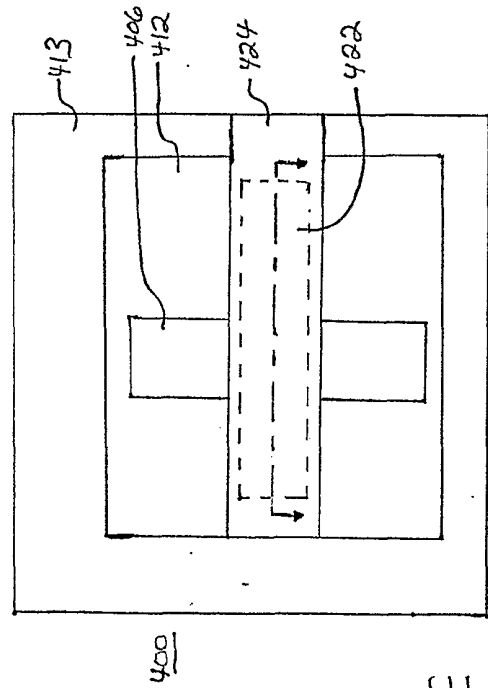

FIG. 4C

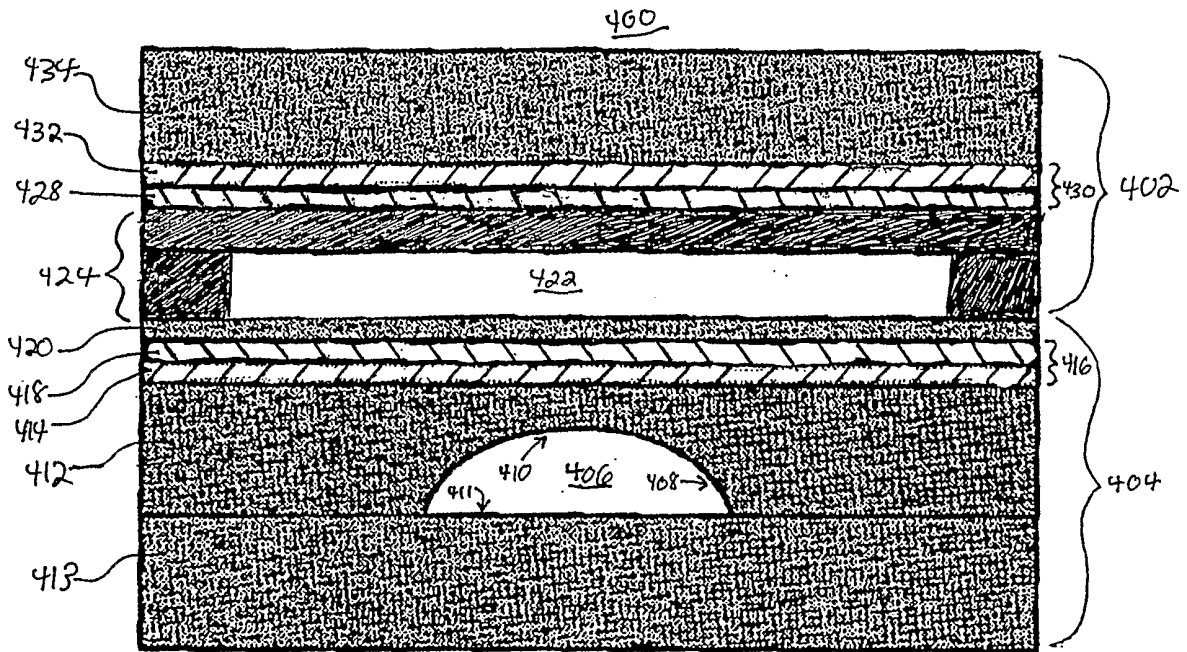

FIG. 4A

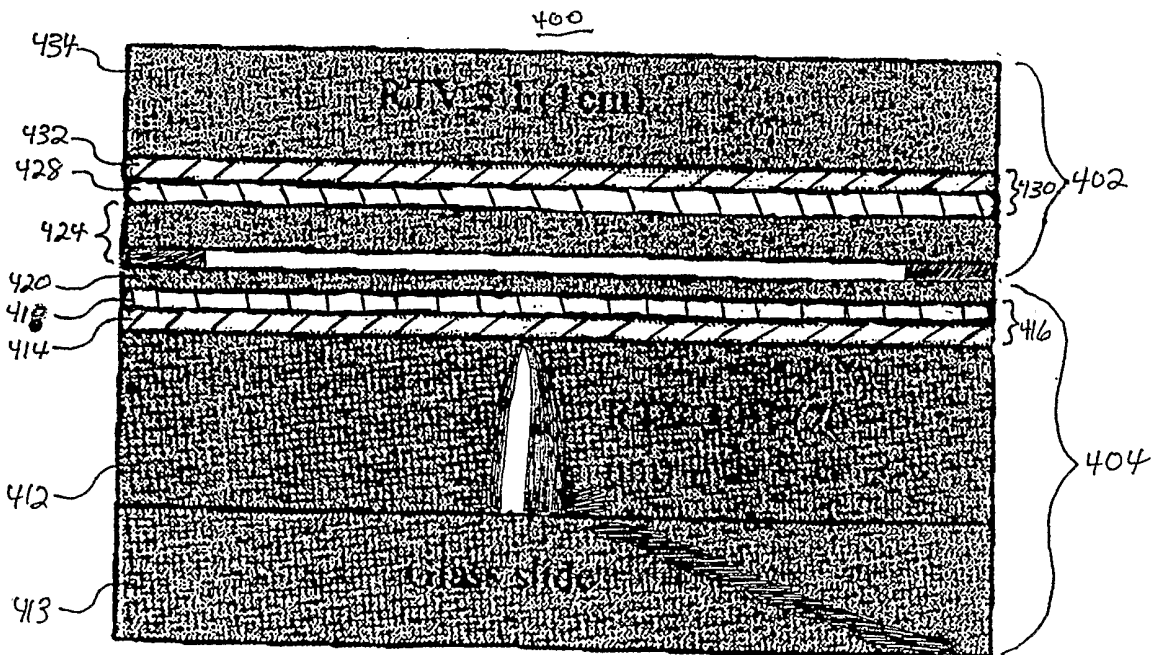

FIG. 4B

# INTERNATIONAL SEARCH REPORT

International application No.

PCT/US01/50490

**A. CLASSIFICATION OF SUBJECT MATTER**

IPC(7) : F16K 31/02

US CL : 251/129.01

According to International Patent Classification (IPC) or to both national classification and IPC

**B. FIELDS SEARCHED**

Minimum documentation searched (classification system followed by classification symbols)

U.S. : 251/129.01

Documentation searched other than minimum documentation to the extent that such documents are included in the fields searched

Electronic data base consulted during the international search (name of data base and, where practicable, search terms used)

**C. DOCUMENTS CONSIDERED TO BE RELEVANT**

Category *	Citation of document, with indication, where appropriate, of the relevant passages	Relevant to claim No.
X	US 5,307,186 A (IZUMI et al) 26 April 1994 (26.04.1994), see entire document.	1-11
X	US 5,452,878 A (GRAVESEN et al) 26 September 1995 (26.09.1995), see entire document.	1-4 and 9-11
X	US 5,971,355 A (BIEGELSEN et al) 26 October 1999 (26.10.1999), see entire document.	1, 3, 5, 7, 9, and 10

Further documents are listed in the continuation of Box C.  See patent family annex.

* Special categories of cited documents:	
"A" document defining the general state of the art which is not considered to be of particular relevance	"T" later document published after the international filing date or priority date and not in conflict with the application but cited to understand the principle or theory underlying the invention
"E" earlier application or patent published on or after the international filing date	"X" document of particular relevance; the claimed invention cannot be considered novel or cannot be considered to involve an inventive step when the document is taken alone
"L" document which may throw doubts on priority claim(s) or which is cited to establish the publication date of another citation or other special reason (as specified)	"Y" document of particular relevance; the claimed invention cannot be considered to involve an inventive step when the document is combined with one or more other such documents, such combination being obvious to a person skilled in the art
"O" document referring to an oral disclosure, use, exhibition or other means	"&" document member of the same patent family
"P" document published prior to the international filing date but later than the priority date claimed	

Date of the actual completion of the international search 21 June 2002 (21.06.2002)	Date of mailing of the international search report <b>12 JUL 2002</b>
--	--

Name and mailing address of the ISA/US Commissioner of Patents and Trademarks Box PCT Washington, D.C. 20231 Facsimile No. (703)305-3230	Authorized officer Henry C. Yuen <i>A. Huxley</i> Telephone No. (703) 308-0861
--	--