

Feb. 24, 1953

B. B. HOLMES

2,629,375

EXHALATION VALVE

Filed Oct. 20, 1950

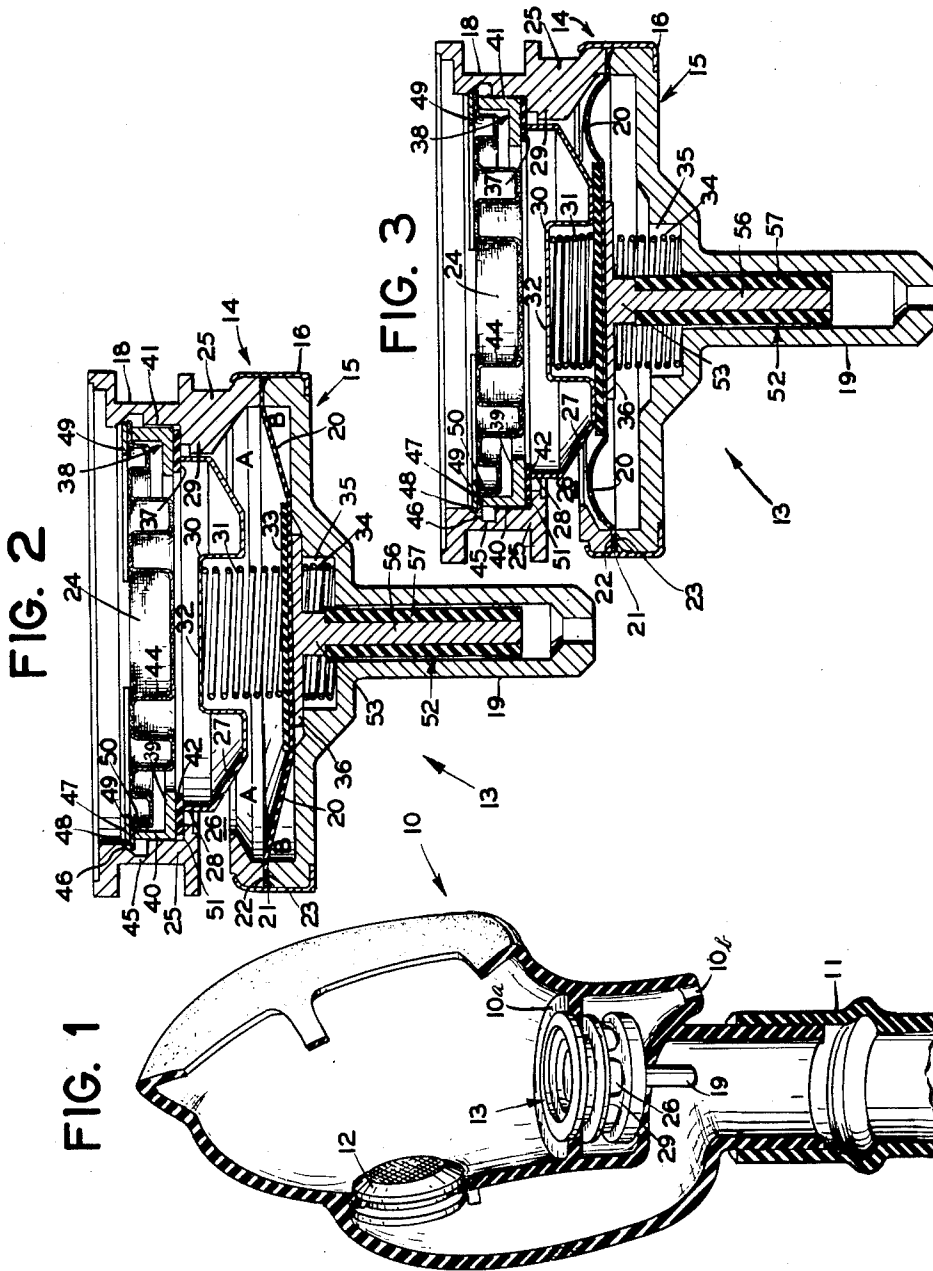

INVENTOR.  
BRADFORD B. HOLMES  
BY

*Bradford B. Holmes*  
- ATTORNEY -

# UNITED STATES PATENT OFFICE

2,629,375

## EXHALATION VALVE

Bradford B. Holmes, New York, N. Y., assignor to  
Bendix Aviation Corporation, Teterboro, N. J.,  
a corporation of Delaware

Application October 20, 1950, Serial No. 191,305

12 Claims. (Cl. 128—140)

1

This invention generally relates to valves and more particularly has to do with a check valve such as is used as an exhalation valve in a pressure-breathing mask of the type utilized in aviation to supply oxygen to the user of the mask under a pressure in excess of the ambient pressure.

In the design and construction of exhalation valves, it is important that the coacting surfaces of the valve disc and valve seat meet in close agreement to the end that any leakage at this point may be held to an absolute minimum. While it is possible to grind or lap the mating surfaces of the valve disc and its coacting seat during the manufacture thereof so as to insure a close fit therebetween, it has been found that any warpage or distortion of the valve casing results in the destruction of the close mating of these surfaces and, therefore, leakage occurs around the valve disc. Moreover, valve discs heretofore used have been constructed in the form of flat or slightly concave discs with the result that the grinding or lapping thereof has presented many difficulties.

Since an exhalation valve of the above noted type is normally actuated by the pressure or force of the exhalations of the person using the mask, it is desirable to have the valve operate smoothly and in response to a low actuating force in order to prevent placing any undue burden on the user of the mask. It is apparent, therefore, that a valve disc having a relatively large area is desirable and will respond to a lower actuating pressure than a valve disc having a small area. Thus, where valve discs have been constructed in the form of flat or slightly concave discs, the result has been that where the valve disc was of sufficient area to respond to a low actuating pressure, it has also been subject to undesirable warpage and distortion resulting in leakage at the valve disc.

The instant invention contemplates, and has for one of its objects, the provision of a novel check or exhalation valve in which the coacting surfaces of the valve disc and valve seat may be manufactured to meet in close agreement in order to prevent, as far as possible, any leakage through the valve at this point.

Another object contemplated herein is to provide a resiliently supported valve seat to the end that, within limits, warpage or distortion of the valve casing will not effect the operation of the valve, or result in leakage through the valve.

A further object of the instant invention is to provide means whereby a positive force urges the

2

valve seat into sealing engagement with its coacting valve disc.

A still further object of the instant invention is to provide a valve disc of substantially large area, and, therefore, capable of actuation in response to a low actuating force or pressure.

Additionally, the instant invention contemplates an exhalation valve wherein the valve disc is guided during its movement, and means are provided to inhibit or dampen any vibrations thereof to the end that the valve will operate smoothly.

In order to further insure the smooth operation of the valve and to prevent the clogging or jamming thereof, the instant invention also contemplates the provision of a filtering means whereby the air being exhausted from the mask is filtered to remove any impurities or foreign bodies that may be present in the air being exhausted prior to the passing thereof through the valve.

The foregoing and other objects and advantages will appear more fully hereinafter from a consideration of the detailed description which follows, taken together with the accompanying drawing wherein one embodiment of the invention is illustrated by way of example.

It is to be expressly understood, however, that the drawing is for purposes of illustration only, and is not to be construed as defining the limits of the invention.

Referring to the drawing wherein like reference characters designate like parts through the three views:

Fig. 1 is a diagrammatic sketch showing the instant valve associated with a portion of a pressure breathing mask and the inlet hose thereof.

Fig. 2 is a longitudinal section through the novel valve hereof showing the position of the valve elements in the presence of negative pressure or suction within the inlet hose.

Fig. 3 is a similar section showing the position of the valve elements in the presence of positive pressures within the mask and inlet hose.

Pressure breathing masks of the type used in aviation are normally adapted to be associated with an oxygen supply system that includes a regulator which operates under certain conditions to permit the person using the mask to breathe ambient atmosphere, while under certain other conditions oxygen is delivered to the mask under predetermined pressures.

Referring now to the drawing for a more detailed description of the present invention and more particularly to Figure 1 thereof, the novel exhalation valve hereof is shown as applied to a

3

pressure breathing mask 10 having an inlet hose 11 that is adapted to be connected to the regulator of an oxygen supply system (not shown). A check valve 12 in the mask 10 operates to permit either ambient atmosphere or oxygen under pressure to enter the interior of the mask 10 through the inlet hose 11.

The novel exhalation valve assembly forming the subject matter of this invention is generally designated with the reference character 13 and comprises, as shown in Figure 2, a valve body 14 and a cap 15 that are clampingly held together by a resilient ring 16 to form a valve casing. A peripheral groove 18 formed in the valve body 14 is adapted to be clampingly and sealingly received in a rubber grommet 10a of the mask 10 and positions the valve assembly 13 adjacent the mouth of the person using the mask 10. A hollow cylindrical extension 19 formed on the cap 15 serves as a means whereby the valve assembly 13 may be associated with the inlet hose 11.

Referring now to Figure 3 wherein the valve assembly 13 is shown in section, it is seen that an elastic diaphragm 20 having the circular edge 21 thereof clamped between mating surfaces 22 and 23 of the valve body 14 and cap 15, respectively, by the clamping ring 16, serves to divide the valve casing into a valve body compartment A, and a cap compartment B. The body compartment A principally serves to house the valve elements whereby the air to be exhausted from the mask 10 may be controlled, while the cap compartment B principally serves to house the elements of a dampening device whereby any "chatter" or vibration of the valve elements are inhibited or dampened.

To provide means whereby the air to be exhausted from the mask 10 may pass through the body compartment A and be controlled by the valve elements therein, the valve body 14 has a circular opening or inlet port 24 in one end thereof opening into the interior of the mask 10, and the wall 25 of the body 14 is pierced at spaced intervals by radial openings or exhaust ports 26 in communication with the ambient atmosphere.

In order to control communication between the inlet port 24 and the exhaust ports 26, a valve disc 27 is provided with a straight side wall 28 that is adapted to slidably engage the wall 25 of the body 14 and the sections 29 of the wall 25 intermediate the exhaust ports 26. A cup-like depression 30 formed in the central portion of the valve disc 27 serves to house a light compression spring 31 that operates between the end wall 32 of the cup 30, and a circular plate 33 secured to the diaphragm 20. A second spring 34 having one end thereof seated within a recess 35 formed in the cap 15 operates against a circular plate 36 that engages the diaphragm 20 in opposition to the plate 33. The springs 31 and 34, therefore, form in effect a single spring that operates to urge the rim or edge 37 of the valve disc 27 into sealing contact with a resiliently supported valve seat assembly generally designated by the reference character 38. Thus, the valve disc 27 is mounted for limited reciprocation within the valve body 14 and normally is urged into sealing contact with the valve seat assembly 38 to close communication between the inlet port 24 and the exhaust ports 26.

It is to be noted that due to the particular conformation or shape of the valve disc 27, i. e., its concave form, the vertical wall 28, and the cup 30, the valve disc 27 forms in effect a rigid structural member, and, therefore, may be con-

4

structed so as to have a relatively large area without any attendant tendency to warp or distort.

It is to be further noted that the effective area of the diaphragm 20 exposed to interior of the cap 15, is somewhat greater than the effective area of the inner surface of the valve disc 27 exposed to the interior of the mask 10. The purpose of the aforementioned relative areas will be hereinafter more fully set forth in the explanation of the operation of the valve assembly 13.

The valve seat assembly 38 comprises a retaining ring 39 having a normally disposed sleeve or flange 40 that is adapted to be slidably received within an annular recess 41 formed in the wall 25, and a resilient ring seal or gasket 42 co-extensive with the inner surface of the ring 39. To provide a smooth, flat base for the seal 42, the inner surface of the ring 39 is lapped or ground as smooth as possible.

To resiliently or yieldably support and operatively position the valve seat assembly 38 within the compartment A, and also to operatively position a filter or screen 44 relative to the inlet port 24, an annular groove 45 having an outwardly sloping or inclined wall 46 is formed in the wall 25 adjacent the inlet port 24. A snap ring 47 is positioned within the groove 45 with the outer edge 48 of the snap ring 47 in engagement with the sloping wall 46, while the inner surface 49 of the snap ring 47 bears against the edge portion 50 of the screen 44 which in turn abuts the edge of the sleeve 40. Thus, when the snap ring 47 is compressed and the edge 48 thereof engaged with the sloping wall 46, the tendency of the snap ring 47 to expand will cause it to slip or slide inwardly on the wall 46 thereby clamping the edge 50 of the screen 44 against the edge of the sleeve 40. Moreover, the ring 39 will be urged in the direction of an internal shoulder 51 formed in the wall 25 by the recess 41 and the seal 42 will, therefore, be clamped between the shoulder 51 and the ring 39.

It is apparent, therefore, that the valve seat assembly 38, and the resilient support thereof hereinbefore described, is adapted to substantially reduce, if not entirely eliminate any leakage past the valve disc 27 in the event the valve body 14 should warp or distort. For, should any warpage of the body 14 occur, the snap ring 47 will slide on the sloping wall 46 to alter its position thereby compensating for the distortion or warpage of the body 14.

The cap compartment B houses a dampening device generally designated with the reference character 52, whereby any "chatter" or undesired vibration of the valve disc may be substantially reduced, if not entirely eliminated. The dampening device 52 comprises a central boss 53 formed on the plate 36 and a rod 56 extending centrally therefrom into the hollow extension 19 of cap 15. A soft rubber sleeve 57 embraces the rod 56. It is apparent, therefore, that any vibration or "chatter" of the valve disc 27 will be transmitted through the plate 36 and boss 53 to the rod 56 and its sleeve 57 will contact or rub against the interior wall of the extension 19 thereby inhibiting or dampening the vibration of the valve disc 27.

The cap compartment B also serves as a pressure chamber whereby the diaphragm 20 may be actuated in response to the pressure within the inlet hose 11 or the mask 10 and to that end the rod 56 and its coacting rubber sleeve 57 are of slightly smaller diameter than the inside diameter of the extension 19. Thus, pressure with-

in the inlet hose 11 passes between the sleeve 57 and the extension 19 into the compartment B. The purpose of thus actuating the diaphragm 20 will be apparent from the following description of the operation of the valve assembly 13.

When the regulator of the system is operating to permit the person using the mask 10 to breathe ambient atmosphere, the hose 11 delivers the ambient atmosphere to the interior of the mask 10. By virtue of the inlet hose 11, inlet port 24 and the exhaust ports 26, the opposed sides of the diaphragm and the valve disc 27 are, therefore, exposed to the ambient atmospheric pressure during the intervals between inhalations and exhalations. Under this condition, the rim 37 of the valve disc 27 is held against the gasket 42 of the seat assembly by the springs 31 and 34 which operate in effect as a single spring.

Upon inhalation, the check valve 12 in the mask 10 opens to permit ambient atmosphere to be delivered to the interior of the mask 10 thus creating a flow within the inlet hose 11 that produces a slight suction or negative pressure in the cap compartment B. The diaphragm 20 will, therefore, move in the direction of the cap 15 in response to this negative pressure within the cap compartment B, and the spring 34 will be compressed and the spring 31 permitted to expand. However, the spring 31 is of such an order as to provide a seating force on the valve disc 27 even upon the full compression of the spring 34.

During the interval between inhalation and exhalation, the valve elements will resume the position previously set forth.

Upon exhalation, air being exhaled will pass through the inlet port 24 and the screen or filter 44 into the body compartment A. The pressure of the air being exhaled is directed against the inner surface of the valve disc 27 and produces a force of sufficient magnitude to unseat the valve disc 27 from the valve seat assembly 38 against the force exerted upon it by the springs 31 and 34 thus permitting the exhaled air to be vented to the atmosphere through the exhaust ports 26 and the vent 10b in the mask 10.

As soon as the pressure of the exhalation falls below the valve or force exerted by the springs 31 and 34, the valve disc 27 will once more be resealed on the valve seat assembly 38 by the action of the springs 31 and 34 thus closing communication between the inlet port 24 and the exhaust ports 26.

When the regulator is operating to deliver oxygen under "safety pressure" or for pressure breathing, a positive pressure relative to the ambient atmospheric pressure is always present in the mask 10 and the inlet hose 11 thereof. Therefore, the inlet hose 11 will deliver this pressure to the cap compartment B to the end that the side of the diaphragm 20 within the cap compartment B will be under a pressure greater than the opposite side of the diaphragm 20 which is exposed to ambient atmospheric pressure by the exhaust port 26. The diaphragm 20 will, therefore, be urged against the valve disc 27 by a force produced by this pressure differential acting upon the opposed surfaces of the diaphragm 20. While the positive pressure within the mask 10 acting through the valve disc 27 will produce a force acting in opposition to the force urging the diaphragm 20 into contact with the valve disc 27, the effective area of the diaphragm 20 is, as hereinbefore set forth, of somewhat greater area of the valve disc 27. Therefore, the net force produced by the pressure differential acts in the di-

rection of seating the valve disc 27 on the valve seat assembly 38. Thus, under conditions where it is of greatest importance to prevent leakage through the valve assembly 13, the seating force of the spring 31 and 34 is augmented by the action of the diaphragm 20 to the end that a highly efficient seal is produced between the valve disc 27 and the valve seat assembly 38.

Under conditions of safety pressure or pressure breathing, the valve disc 27 will be held in sealing contact with the valve seat assembly 38 during the intervals between inhalation and exhalation, as hereinbefore set forth.

Due to the positive pressure delivered by the regulator, an inhalation will not produce a suction or negative pressure within the cap compartment B and the valve elements will, therefore, remain in the same relative positions as set forth with regard to their positions during intervals between inhalation and exhalation.

Upon exhalation, the air to be exhaled passes through the inlet port 24, is filtered by the screen 44 and the pressure thereof acts upon the inner surface of the valve disc 27 to produce a force that unseats the valve disc 27 from the valve seat assembly 38 against the forces acting to hold the disc 27 in engagement with its co-acting valve seat assembly 38 as previously described, and the exhaled air vents to the atmosphere through the exhaust ports 26. When the force produced by the exhalation falls below the value of the forces tending to the seat the valve disc 27, the valve disc will be re-engaged with its valve seat assembly 38 to close communication between the inlet port 24 and the exhaust ports 26.

During the operation of the valve elements under any of the foregoing conditions, the dampening device 52 will serve to inhibit or dampen any vibration of the valve disc 27, as previously set forth.

There has thus been provided a novel exhalation valve wherein the several objects of this invention are achieved and which is well adapted to meet the conditions of practical use.

Although only one embodiment of the invention has been illustrated and described in detail, it is to be expressly understood that the invention is not limited thereto. Various changes can be made on the design and arrangement of the parts without departing from the spirit and the scope of the invention as the same will now be understood by those skilled in the art.

I claim:

1. An exhalation valve assembly adapted for use with a pressure breathing mask having an inlet hose whereby ambient atmosphere or oxygen is delivered under varying pressures to the interior of said mask, said valve assembly comprising a valve body, a cap, means for securing said cap to said body to form a valve casing, a diaphragm mounted in said casing dividing said casing into cap and body compartments, said body including means whereby said valve assembly may be operatively associated with said mask, an inlet port in said body for placing the interior of said mask in communication with the interior of said body compartment, exhaust ports in said body for placing the interior of said body compartment and one side of said diaphragm in communication with the ambient atmosphere, a valve seat resiliently supported within said body, a valve disc mounted for guided and limited reciprocation in said body and adapted to sealingly engage said valve seat, resilient means co-

operating with said diaphragm for biasing said valve disc into sealing contact with said valve seat to close communication between said inlet and exhaust ports, means for placing the interior of said cap compartment in communication with said inlet hose whereby said diaphragm responds to pressures within said inlet hose to effect the resilient means biasing said valve disc into sealing contact with said valve seat, and dampening means within said cap compartment to inhibit vibration of said valve disc.

2. An exhalation valve assembly for use with a pressure breathing mask having an inlet hose whereby ambient atmosphere or oxygen may be delivered under varying pressures to the interior of said mask, said valve assembly comprising a body, a cap, means for securing said cap to said body to form a valve casing, a diaphragm mounted in said casing and dividing said casing into body and cap compartments, said body including means whereby said valve assembly may be operatively associated with said mask, an inlet port in said body placing the interior of said mask in communication with the interior of said body compartment, exhaust ports in said body placing the interior of said body compartment in communication with the atmosphere, a valve seat resiliently mounted in said body, a valve disc mounted for guided and limited reciprocation in said body and adapted to sealingly engage said valve seat, means cooperating with said diaphragm for biasing said valve disc into sealing contact with said valve seat to close communication between said inlet and exhaust ports, means for placing the interior of said cap compartment in communication with said inlet hose, and dampening means within said cap compartment to inhibit vibration of said valve disc.

3. An exhalation valve assembly adapted for use with a pressure breathing mask having an inlet hose whereby ambient atmosphere or oxygen may be supplied under varying pressures to the interior of said mask, said valve assembly comprising a valve casing having an inlet port, means for securing said valve casing to said mask with the inlet port in communication with the interior of said mask, exhaust ports in said casing in communication with said inlet port and the ambient atmosphere, a valve seat resiliently supported within said casing, a valve disc mounted for reciprocation within said casing and adapted to engage said valve seat, a diaphragm mounted within said casing, resilient means cooperating with said diaphragm and valve disc whereby said valve disc is positioned on said valve seat to close communication between said inlet and exhaust ports, and means for placing one side of said diaphragm in communication with said inlet hose whereby said diaphragm responds to the pressure within said inlet hose to thereby effect the operation of said resilient means.

4. An exhalation valve assembly adapted for use with a breathing mask comprising a casing having an inlet port, means for associating said casing to said mask with the inlet port thereof in communication with the interior of said mask, exhaust ports in said casing communicating with said inlet port and with the ambient atmosphere, said casing being provided with an annular recess defining a shoulder in said casing, a valve seat including a retaining ring having a normally disposed sleeve adapted to be slidably received in the recess in said casing and a resilient gasket positioned on and coextensive with the surface

of said ring opposed to said sleeve, said casing being provided with an annular groove having a sloping wall, a snap ring positioned in said groove with the outer edge thereof slidably engaged with the sloping wall and the inner surface thereof abutting the end of said sleeve whereby said ring is resiliently biased toward said shoulder to thereby clampingly engage the edge portion of said gasket between said shoulder and said ring, a concave valve disc having a straight side wall whereby said valve disc is mounted for reciprocation in said casing, and means for resiliently biasing said valve disc in the direction of said valve seat to close communication between said inlet and exhaust ports.

5. An exhalation valve assembly adapted for use with a breathing mask comprising a casing having an inlet port, means for associating said casing to said mask with the inlet port thereof in communication with the interior of said mask, exhaust ports in said casing communicating with said inlet port and with the ambient atmosphere, said casing being provided with an annular recess defining a shoulder in said casing, a valve seat including a retaining ring having a normally disposed sleeve adapted to be slidably received in the recess in said casing and a resilient gasket positioned on and coextensive with the surface of said ring opposed to said sleeve, said casing being provided with an annular groove having a sloping wall, a snap ring positioned in said groove with the outer edge thereof slidably engaged with the sloping wall and the inner surface thereof abutting the end of said sleeve whereby said ring is resiliently biased toward said shoulder to thereby clampingly engage the edge portion of said gasket between said shoulder and said ring, a concave valve disc having a straight side wall whereby said valve disc is mounted for reciprocation in said casing, the edge of said wall being adapted to engage the gasket of said valve seat, a central depression formed in said valve disc, a diaphragm mounted in said casing, and a spring partially housed in the depression in said valve disc and operating against said diaphragm to sealingly engage the edge of the wall of said valve disc into sealing contact with the gasket of said valve seat to close communication between said inlet and exhaust ports.

6. An exhalation valve assembly adapted for use with a pressure breathing mask having an inlet hose whereby ambient atmosphere or oxygen is delivered under varying pressures to the interior of said mask, and an outlet vent in communication with the ambient atmosphere, said valve assembly comprising a casing, inlet and exhaust ports in said casing, means for associating said casing with said mask with said inlet port in communication with the interior of said mask and the exhaust ports communicating with said outlet vent, said casing having an internal annular recess defining a shoulder in said casing, a valve seat including a retaining ring having a normally disposed sleeve and a resilient gasket positioned on and coextensive with the surface of said ring opposed to said sleeve, said retaining ring being adapted to have its outer edge portion engage said shoulder and said sleeve being adapted to be slidably received in the recess in said casing, said casing being provided with an annular groove having an outwardly sloping wall, a resilient ring-like compression member having an outer edge and inner surface positioned in said groove with the outer edge slidably engaging said sloping wall and the inner

surface abutting the free end of said sleeve whereby said retaining ring is resiliently biased toward said shoulder to thereby clampingly engage the edge portion of said resilient gasket between said shoulder and said retaining ring, a valve disc substantially concave in form and having a straight side wall defining a rim on said valve disc, the walls of said valve disc being adapted to be slidably received in said casing and said rim being adapted to engage the gasket of said valve seat, a depression formed in said valve disc, a diaphragm mounted in said casing, a spring operating between said casing and one side of said diaphragm, a second spring operating between the depression in said valve disc and the other side of said diaphragm, said springs cooperating to sealingly engage the rim of said valve disc with the gasket of said valve seat to close communication between said inlet and exhaust ports, and means for actuating said diaphragm in response to pressure differentials existing between the pressures within the interior of said mask and inlet hose and the pressure of the ambient atmosphere in the outlet vent of said mask to thereby effect the operation of the springs aforesaid and the sealing engagement of the rim of said valve disc with the gasket of said valve seat.

7. A valve assembly comprising a casing having inlet and exhaust ports, a valve seat slidably mounted in said casing, a concave valve disc slidably mounted in said casing and having a rim adapted to engage said valve seat to thereby close communication between said inlet and exhaust ports, resilient means biasing the rim of said valve disc into sealing engagement with said valve seat, and means for yieldably supporting said valve seat in said casing.

8. A valve assembly comprising a casing having inlet and exhaust ports, a valve seat slidably mounted and resiliently supported in said casing, a valve disc slidably mounted in said casing and adapted to engage said valve seat, and resilient means in said casing urging said valve disc into sealing contact with said valve seat to thereby close communication between said inlet and exhaust ports.

9. A valve assembly comprising a casing having inlet and exhaust ports, a resiliently supported valve seat slidably mounted in said casing, a valve disc slidably mounted in said casing and for limited reciprocation therein and adapted to sealably engage said valve seat, a diaphragm mounted in said casing, and resilient means associated with said diaphragm and valve disc for urging said valve disc into sealing engagement with said valve seat to close communication between said inlet and exhaust ports.

10. In a valve assembly for controlling and filtering the flow of a fluid, the combination comprising a casing having inlet port for deliver-

ing a fluid into said casing, and an exhaust port for discharging the fluid from said casing, a resiliently supported valve seat mounted in said casing, a valve disc mounted for limited reciprocation in said casing and adapted to sealably engage said valve seat, a diaphragm mounted in said casing, resilient means cooperating with said diaphragm and valve disc for urging said valve disc into sealing engagement with said valve seat to close communication between said inlet and exhaust ports and thereby prevent the flow of the fluid through said casing, and a filter interposed between said inlet port and said valve disc to filter the fluid passing through said casing when said valve disc is disengaged from said valve seat.

11. In a valve assembly for controlling the flow of a fluid, the combination comprising a casing having inlet port for delivering a fluid into said casing and an exhaust port for discharging the fluid from said casing, a valve seat resiliently mounted in said casing, a valve disc slidably mounted in said casing and adapted to sealably engage said valve seat, a diaphragm mounted in said casing, resilient means cooperating with said diaphragm and valve disc to urge said valve disc into sealing engagement with said valve seat to thereby close communication between said inlet and exhaust ports and prevent the flow of fluid through said casing, means for actuating said diaphragm in response to a pressure differential between the opposed sides thereof to thereby effect the operation of said resilient means on said valve disc and a filter interposed between said inlet port and said valve disc to filter the fluid passing through said casing when said valve disc is disengaged from said valve seat.

12. A valve comprising a housing having inlet and exhaust ports, a valve seat assembly in engagement with an internal wall of said housing and arranged for movement relative thereto, a valve member intermediate said inlet and exhaust ports and movable for engagement with said valve seat assembly to thereby close communication between said ports, the internal wall of said housing adjacent said valve seat assembly being formed with an inclined portion, and expansible means cooperating with said inclined wall portion for urging said valve seat assembly into sealable engagement with said valve member.

BRADFORD B. HOLMES.

#### REFERENCES CITED

The following references are of record in the file of this patent:

#### UNITED STATES PATENTS

Number	Name	Date
948,404	Webb	Feb. 8, 1910
1,359,631	Teed	Nov. 23, 1920
2,453,475	Tobias	Nov. 9, 1948