

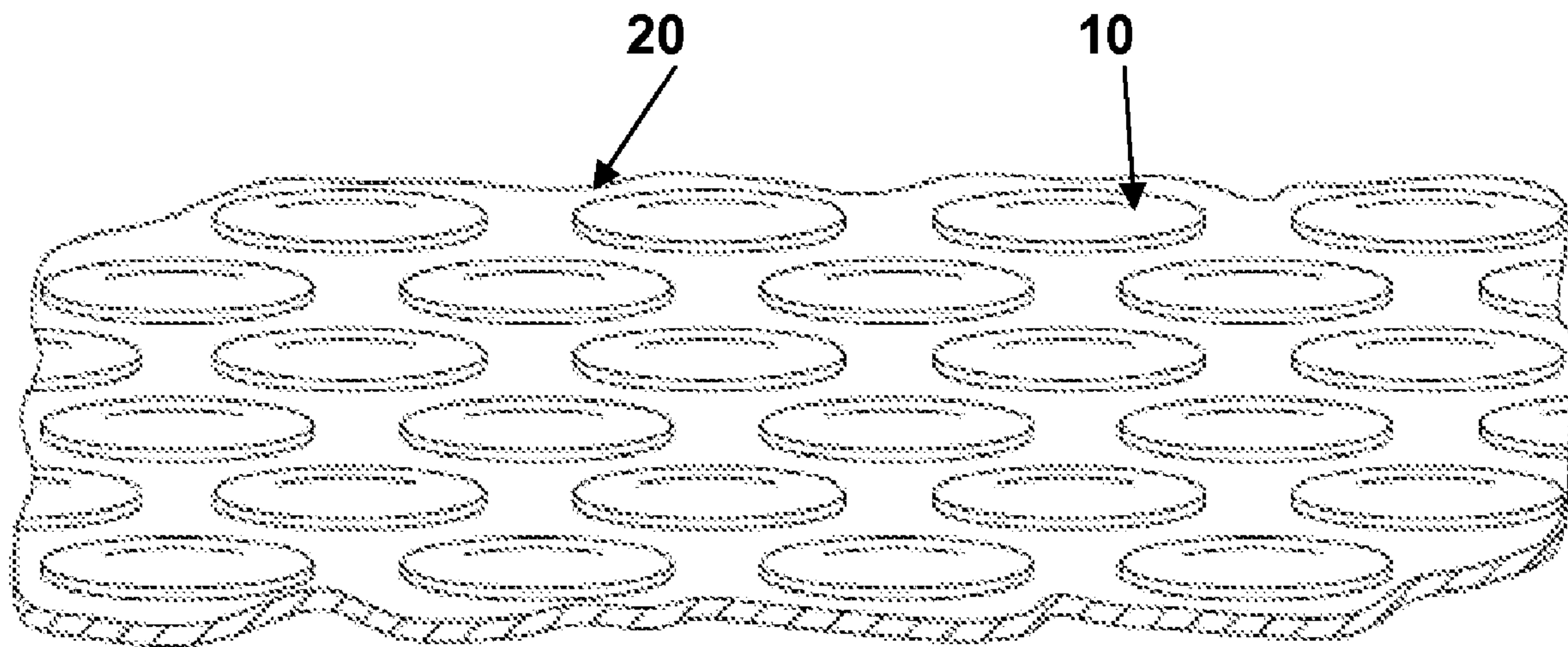

(86) Date de dépôt PCT/PCT Filing Date: 2010/05/07
 (87) Date publication PCT/PCT Publication Date: 2010/11/11
 (45) Date de délivrance/Issue Date: 2014/09/30
 (85) Entrée phase nationale/National Entry: 2011/11/04
 (86) N° demande PCT/PCT Application No.: US 2010/034124
 (87) N° publication PCT/PCT Publication No.: 2010/129923
 (30) Priorités/Priorities: 2009/05/07 (US29/336,730);
 2009/05/07 (US61/176,448); 2009/11/05 (US29/346,788);
 2009/11/05 (US29/346,784); 2009/11/05 (US29/346,787);
 2009/11/05 (US29/346,786); 2009/11/05 (US29/346,785);
 2010/04/23 (US29/360,364)

(51) Cl.Int./Int.Cl. *A41D 13/005* (2006.01),
A41D 13/00 (2006.01), *A41D 13/002* (2006.01)
 (72) Inventeur/Inventor:
 BLACKFORD, WOODY, US
 (73) Propriétaire/Owner:
 COLUMBIA SPORTSWEAR NORTH AMERICA, INC.,
 US
 (74) Agent: BORDEN LADNER GERVAIS LLP

(54) Titre : **MATERIAU DE GESTION DE CHALEUR A MOTIF**
 (54) Title: **PATTERNED HEAT MANAGEMENT MATERIAL**



(57) **Abrégé/Abstract:**

Embodiments of the present disclosure relate generally to body gear having designed performance characteristics, and in particular to methods and apparatuses that utilize an array of heat managing elements coupled to a base material to direct body heat while also maintaining the desired transfer properties of the base material. In some embodiments, the heat managing material elements include heat management elements that reflect heat or conduct heat, and may be directed towards the body of a user or away from the body of the user.

(12) INTERNATIONAL APPLICATION PUBLISHED UNDER THE PATENT COOPERATION TREATY (PCT)

CORRECTED VERSION

(19) World Intellectual Property Organization
International Bureau(43) International Publication Date
11 November 2010 (11.11.2010)

PCT

(10) International Publication Number
WO 2010/129923 A8

(51) International Patent Classification:

A41D 13/005 (2006.01) A41D 13/00 (2006.01)
A41D 13/002 (2006.01)

(21) International Application Number:

PCT/US2010/034124

(22) International Filing Date:

7 May 2010 (07.05.2010)

(25) Filing Language:

English

(26) Publication Language:

English

(30) Priority Data:

61/176,448	7 May 2009 (07.05.2009)	US
29/336,730	7 May 2009 (07.05.2009)	US
29/346,787	5 November 2009 (05.11.2009)	US
29/346,784	5 November 2009 (05.11.2009)	US
29/346,788	5 November 2009 (05.11.2009)	US
29/346,785	5 November 2009 (05.11.2009)	US
29/346,786	5 November 2009 (05.11.2009)	US
29/360,364	23 April 2010 (23.04.2010)	US

(81) Designated States (unless otherwise indicated, for every kind of national protection available): AE, AG, AL, AM, AO, AT, AU, AZ, BA, BB, BG, BH, BR, BW, BY, BZ, CA, CH, CL, CN, CO, CR, CU, CZ, DE, DK, DM, DO, DZ, EC, EE, EG, ES, FI, GB, GD, GE, GH, GM, GT, HN, HR, HU, ID, IL, IN, IS, JP, KE, KG, KM, KN, KP, KR, KZ, LA, LC, LK, LR, LS, LT, LU, LY, MA, MD, ME, MG, MK, MN, MW, MX, MY, MZ, NA, NG, NI, NO, NZ, OM, PE, PG, PH, PL, PT, RO, RS, RU, SC, SD, SE, SG, SK, SL, SM, ST, SV, SY, TH, TJ, TM, TN, TR, TT, TZ, UA, UG, US, UZ, VC, VN, ZA, ZM, ZW.

(84) Designated States (unless otherwise indicated, for every kind of regional protection available): ARIPO (BW, GH, GM, KE, LR, LS, MW, MZ, NA, SD, SL, SZ, TZ, UG, ZM, ZW), Eurasian (AM, AZ, BY, KG, KZ, MD, RU, TJ, TM), European (AL, AT, BE, BG, CH, CY, CZ, DE, DK, EE, ES, FI, FR, GB, GR, HR, HU, IE, IS, IT, LT, LU, LV, MC, MK, MT, NL, NO, PL, PT, RO, SE, SI, SK, SM, TR), OAPI (BF, BJ, CF, CG, CI, CM, GA, GN, GQ, GW, ML, MR, NE, SN, TD, TG).

(71) Applicant (for all designated States except US): **COLUMBIA SPORTSWEAR NORTH AMERICA, INC.** [US/US]; 14375 NW Science Park Drive, Portland, OR 97229 (US).

(72) Inventor; and

(75) Inventor/Applicant (for US only): **BLACKFORD, Woody** [CA/US]; 919 SE 15th Avenue, Portlnad, OR 97214 (US).

(74) Agents: **LEWIS, Christopher, J.** et al.; **SCHWABE, WILLIAMSON & WYATT, P.C.**, 1211 SW Fifth Avenue, Suite 1500-2000, Portland, OR 97204 (US).

Published:

— with international search report (Art. 21(3))

(88) Date of publication of the international search report:

3 February 2011

(48) Date of publication of this corrected version:

24 February 2011

(15) Information about Correction:

see Notice of 24 February 2011

(54) Title: PATTERNED HEAT MANAGEMENT MATERIAL

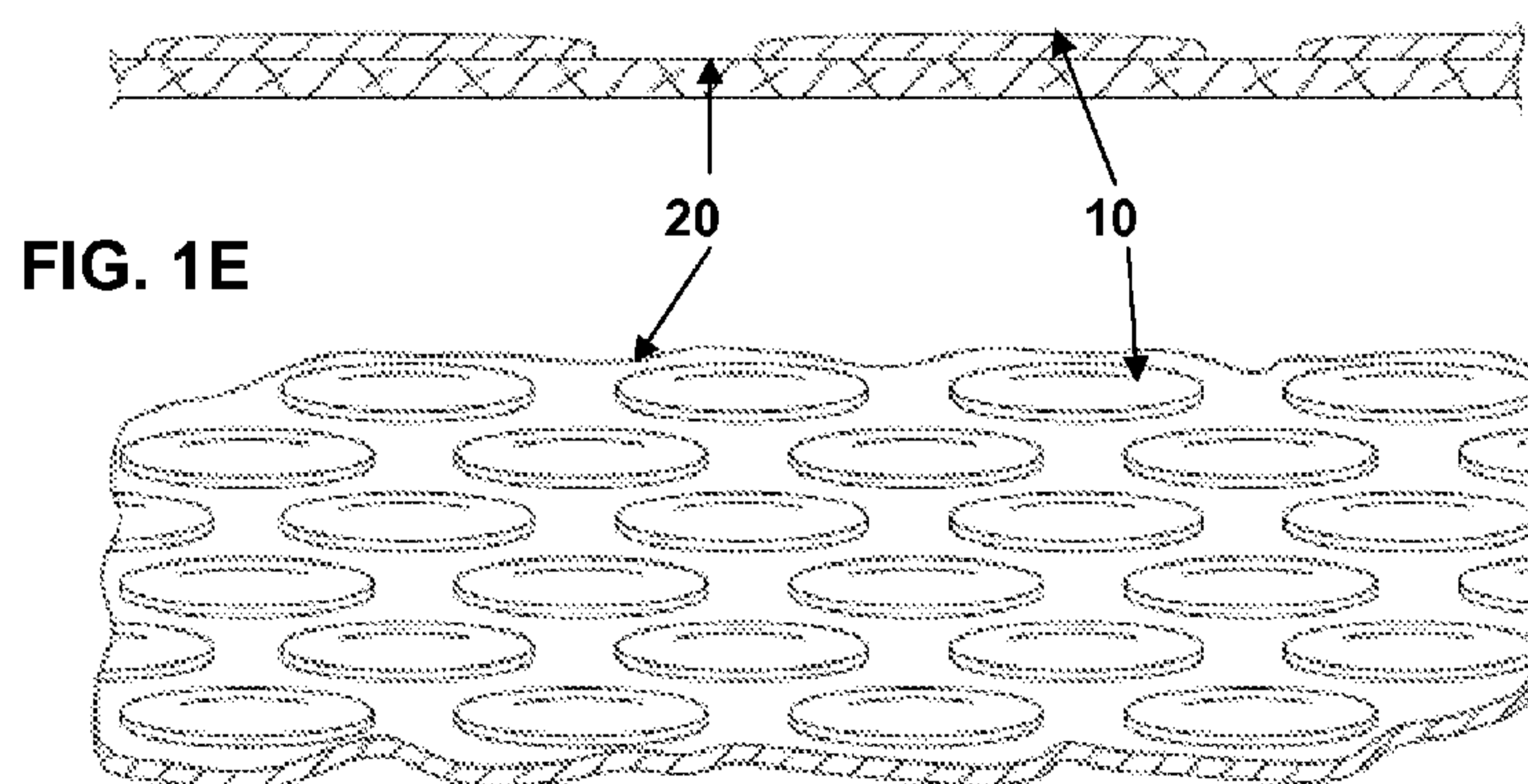

(57) Abstract: Embodiments of the present disclosure relate generally to body gear having designed performance characteristics, and in particular to methods and apparatuses that utilize an array of heat managing elements coupled to a base material to direct body heat while also maintaining the desired transfer properties of the base material. In some embodiments, the heat managing material elements include heat management elements that reflect heat or conduct heat, and may be directed towards the body of a user or away from the body of the user.

PATTERNED HEAT MANAGEMENT MATERIAL

Technical Field

[0002] Embodiments of the present disclosure relate generally to a fabric or other material used for body gear and other goods having designed performance characteristics, and in particular to methods and apparatuses that utilize a pattern of heat managing/directing elements coupled to a base fabric to manage heat through reflection or conductivity while maintaining the desired properties of the base fabric.

Background

[0003] Currently, heat reflective materials such as aluminum and mylar typically take the form of a unitary solid film that is glued or otherwise attached to the interior of a garment, such as a jacket. The purpose of this layer is to inhibit thermal radiation by reflecting the body heat of the wearer and thereby keeping the garment wearer warm in colder conditions. However, these heat reflective linings do not transfer moisture vapor or allow air passage, thus they trap moisture near the body. Because the application of a heat reflective material impedes the breathability and other functions of the underlying base fabric, use of heat reflective materials during physical activity causes the inside of a garment to become wet, thereby causing discomfort and accelerating heat loss due to the increased heat conductivity inherent in wet materials. Further, these heat reflective coated materials impair the ability of the material to stretch, drape, or hang in a desired fashion.

Brief Description of the Drawings

[0004] Embodiments of the present disclosure will be readily understood by the following detailed description in conjunction with the accompanying drawings. Embodiments of the invention are illustrated by way of example and not by way of limitation in the figures of the accompanying drawings.

[0005] **Figures 1A** illustrates an upper body garment such as a coat having a lining of base material with heat directing/management elements disposed thereon, in accordance with various embodiments;

[0006] **Figures 1B – 1E** illustrate various views of examples of patterned heat directing/management elements disposed on a base fabric or material, in accordance with various embodiments;

[0007] **Figures 2A** and **2B** illustrate examples of patterned heat directing/management elements disposed on a base fabric, in accordance with various embodiments;

[0008] **Figures 3A – 3E** illustrate examples of patterned heat directing/management elements disposed on a base fabric, in accordance with various embodiments;

[0009] **Figure 4** illustrates an upper body garment such as a coat having a lining of base material with heat directing/management elements disposed thereon, in accordance with various embodiments;

[0010] **Figure 5** illustrates an upper body garment such as a coat having a lining of base material with heat directing/management elements disposed thereon, in accordance with various embodiments;

[0011] **Figure 6** illustrates an upper body garment such as a coat having a lining of base material with heat directing/management elements disposed thereon, in accordance with various embodiments;

[0012] **Figure 7** illustrates an upper body garment such as a coat having a lining of base material with heat directing/management elements disposed thereon, in accordance with various embodiments;

[0013] **Figures 8A-D** illustrate various views of a patterned heat management material as used in a jacket, in accordance with various embodiments;

[0014] **Figure 9** illustrates an example of a patterned heat management material as used in a boot, in accordance with various embodiments;

[0015] **Figure 10** illustrates an example of a patterned heat management material as used in a glove, where the cuff is rolled outward to show the lining, in accordance with various embodiments;

[0016] **Figure 11** illustrates an example of a patterned heat management material as used in a hat, in accordance with various embodiments;

[0017] **Figure 12** illustrates an example of a patterned heat management material as used in a pair of pants, in accordance with various embodiments;

[0018] **Figure 13** illustrates an example of a patterned heat management material as used in a sock, in accordance with various embodiments;

[0019] **Figure 14** illustrates an example of a patterned heat management material as used in a boot, in accordance with various embodiments; and

[0020] **Figures 15A and B** illustrate two views of a patterned heat management material as used in a reversible rain fly (**Figure 15A**) and as a portion of a tent body (**Figure 15B**), in accordance with various embodiments.

Detailed Description of Embodiments

[0021] In the following detailed description, reference is made to the accompanying drawings which form a part hereof, and in which are shown by way of illustration embodiments in which the disclosure may be practiced. It is to be understood that other embodiments may be utilized and structural or logical changes may be made without departing from the scope of the present disclosure. Therefore, the following detailed description is not to be taken in a limiting sense, and the scopes of embodiments, in accordance with the present disclosure, are defined by the appended claims and their equivalents.

[0022] Various operations may be described as multiple discrete operations in turn, in a manner that may be helpful in understanding embodiments of the present invention; however, the order of description should not be construed to imply that these operations are order dependent.

[0023] The description may use perspective-based descriptions such as up/down, back/front, and top/bottom. Such descriptions are merely used to facilitate the discussion and are not intended to restrict the application of embodiments of the present invention.

[0024] The terms “coupled” and “connected,” along with their derivatives, may be used. It should be understood that these terms are not intended as synonyms for

each other. Rather, in particular embodiments, “connected” may be used to indicate that two or more elements are in direct physical or electrical contact with each other. “Coupled” may mean that two or more elements are in direct physical or electrical contact. However, “coupled” may also mean that two or more elements are not in direct contact with each other, but yet still cooperate or interact with each other.

[0025] For the purposes of the description, a phrase in the form “A/B” or in the form “A and/or B” means (A), (B), or (A and B). For the purposes of the description, a phrase in the form “at least one of A, B, and C” means (A), (B), (C), (A and B), (A and C), (B and C), or (A, B and C). For the purposes of the description, a phrase in the form “(A)B” means (B) or (AB) that is, A is an optional element.

[0026] The description may use the phrases “in an embodiment,” or “in embodiments,” which may each refer to one or more of the same or different embodiments. Furthermore, the terms “comprising,” “including,” “having,” and the like, as used with respect to embodiments of the present invention, are synonymous.

[0027] In various embodiments a material for body gear is disclosed that may use a pattern of heat management material elements coupled to a base fabric to manage, for example, body heat by directing the heat towards or away from the body as desired, while still maintaining the desired transfer properties of the base fabric. For example, referring to **Figures 1B-1E**, in one embodiment, a plurality of heat management or heat directing elements **10** may be disposed on a base fabric **20** in a generally non-continuous array, whereby some of the base fabric is exposed between adjacent heat management elements. The heat directing function of the heat management elements may be generally towards the body through reflectivity or away from the body through conduction and/or radiation or other heat transfer property.

[0028] The heat management elements **10** may cover a sufficient surface area of the base fabric **20** to generate the desired degree of heat management (e.g. heat reflection toward the body to enhance warmth, or heat conductance away from the body to help induce cooling). A sufficient area of base fabric may be exposed to provide the desired base fabric function (e.g., stretch, drape, breathability, moisture vapor or air permeability, or wicking).

[0029] In accordance with various embodiments, the base fabric may be a part of any form of body gear, such as bodywear (see e.g. **Figures 1A** and **4-13**), sleeping bags (see e.g. **Figure 14**), blankets, tents (see e.g. **Figure 15B**), rain flys

(see e.g. **Figure 15A**) etc. Bodywear, as used herein, is defined to include anything worn on the body, including, but not limited to, outerwear such as jackets, pants, scarves, shirts, hats, gloves, mittens, and the like, footwear such as shoes, boots, slippers, and the like, sleepwear, such as pajamas, nightgowns, and robes, and undergarments such as underwear, thermal underwear, socks, hosiery, and the like.

[0030] In various embodiments, single-layer body gear may be used and may be comprised of a single layer of the base fabric, whereas other embodiments may use multiple layers of fabric, including one or more layers of the base fabric, coupled to one or more other layers. For instance, the base fabric may be used as a fabric lining for body gear.

[0031] In various embodiments, the array of heat management elements may be disposed on a base fabric having one or more desired properties. For example, the underlying base material may have properties such as air permeability, moisture vapor transfer and/or wickability, which is a common need for body gear used in both indoor and outdoor applications. In other embodiments, the separations between heat management elements help allow the base material to have a desired drape, look, and/or texture. In some embodiments, the separations between heat management elements help allow the base material to have a desired stretch. Suitable base fabrics may include nylon, polyester, rayon, cotton, spandex, wool, silk, or a blend thereof, or any other material having a desired look, feel, weight, thickness, weave, texture, or other desired property. In various embodiments, allowing a designated percentage of the base fabric to remain uncovered by the heat management material elements may allow that portion of the base fabric to perform the desired functions, while leaving enough heat management material element surface area to direct body heat in a desired direction, for instance away from or toward the body of a user.

[0032] For example, the heat management elements may be positioned in such a way and be made of a material that is conducive for directing heat generated by the body. In one embodiment, the heat management elements may be configured to reflect the user's body heat toward the user's body, which may be particularly suitable in cold environments. In another embodiment, the heat management elements may be configured to conduct the user's body heat away from the user's body, which may be particularly suitable in warmer environments.

[0033] In various embodiments, the base fabric may include heat management elements disposed on an innermost surface of the body gear such that the elements are disposed to face the user's body and thus are in a position to manage body heat, as discussed above (e.g. reflect heat or conduct heat). In some other embodiments, the heat management elements may be disposed on the exterior surface of the body gear and/or base fabric such that they are exposed to the environment, which may allow the heat management elements, for example, to reflect heat away from the user, while allowing the base fabric to adequately perform the desired functions. In some embodiments, the heat management elements may perform these functions without adversely affecting the stretch, drape, feel, or other properties of the base fabric.

[0034] In some embodiments, the heat management elements may be an aluminum-based material (particularly suited for reflectivity), copper based material (particularly suited for conductivity). or another metal or metal alloy-based material. Non-metallic or alloy based materials may be used as heat directing materials in some embodiments, such as metallic plastic, mylar, or other man-made materials, provided that they have heat reflective or conductive properties.

[0035] In various embodiments, the heat management elements may be permanently coupled to the base fabric in a variety of ways, including, but not limited to gluing, heat pressing, printing, or stitching. In some embodiments, the heat management elements may be coupled to the base fabric by frequency welding, such as by radio or ultrasonic welding.

[0036] In various embodiments, the heat directing properties of the heat management elements may be influenced by the composition of the base fabric or the overall construction of the body gear. For example, a base fabric may be used that has significant insulating properties. When paired with heat management elements that have heat reflective properties, the insulative backing/lining may help limit any conductivity that may naturally occur and enhance the reflective properties of the heat management elements. In another example, the base fabric may provide little or no insulative properties, but may be coupled to an insulating layer disposed on the side of the base fabric opposite the heat directing material elements. The separate insulation layer may help reduce the potential for heat conductivity of the elements and enhance their reflectivity. In some embodiments, the heat management elements may become more conductive as the air layer between the

garment and the wearer becomes more warm and humid. Such examples may be suitable for use in cold weather applications, for instance.

[0037] In various embodiments, a base fabric may be used that has little or no insulative properties. When paired with heat directing elements that are primarily configured to conduct heat, as opposed to reflecting heat, the base fabric and heat-directing elements may aid in removing excess body heat generated in warmer climates or when engaging in extreme physical activity. Such embodiments may be suitable for warm weather conditions.

[0038] In various embodiments, the heat management material elements may be applied in a pattern or a continuous or discontinuous array defined by the manufacturer. For example, as illustrated in **Figures 1A -1E**, heat management material elements **10**, may be a series of dot-like heat reflective (or heat conductive) elements adhered or otherwise secured to the base fabric **20** in a desired pattern. Such a configuration has been found to provide heat reflectivity and thus warmth to the user (e.g., when heat reflective elements are used), or, in the alternative, heat conduction and thus cooling to the user (e.g., when heat conductive elements are used), while still allowing the base fabric to perform the function of the desired one or more properties (e.g. breathe and allow moisture vapor to escape through the fabric in order to reduce the level of moisture build up).

[0039] Although the illustrated embodiments show the heat management material elements as discrete elements, in some embodiments, some or all of the heat management material elements may be arranged such that they are in connection with one another, such as a lattice pattern or any other pattern that permits partial coverage of the base fabric.

[0040] In various embodiments, the configuration or pattern of the heat management elements themselves may be selected by the user and may take any one of a variety of forms. For example, as illustrated in **Figures 2A-2B, 3A-3E, and 4-6**, the configuration of the heat management elements **10** disposed on a base fabric **20** used for body gear may be in the form of a variety of geometrical patterns (e.g. lines, waves, triangles, squares, logos, words, etc.)

[0041] In various embodiments, the pattern of heat management elements may be symmetric, ordered, random, and/or asymmetrical. Further, as discussed below, the pattern of heat management elements may be disposed on the base material at strategic locations to improve the performance of the body wear. In

various embodiments, the size of the heat management elements may also be varied to balance the need for enhanced heat directing properties and preserve the functionality of the base fabric.

[0042] In embodiments, the density or ratio of the surface area covered by the heat management material elements to the surface area of base fabric left uncovered by the heat management material elements may be from about 3:7 (30%) to about 7:3 (70%). This range has been shown to provide a good balance of heat management properties (e.g., reflectivity or conductivity) with the desired properties of the base fabric (e.g., breathability or wicking, for instance). In particular embodiments, this ratio may be from about 4:6 (40%) to about 6:4 (60%).

[0043] In various embodiments, the placement, pattern, and/or coverage ratio of the heat management elements may vary. For example the heat management elements may be concentrated in certain areas where heat management may be more critical (e.g. the body core) and non-existent or extremely limited in other areas where the function of the base fabric property is more critical (e.g. area under the arms or portions of the back for wicking moisture away from the body). In various embodiments, different areas of the body gear may have different coverage ratios, e.g. 70% at the chest and 30% at the limbs, in order to help optimize, for example, the need for warmth and breathability.

[0044] In various embodiments, the size of the heat management elements may be largest (or the spacing between them may be the smallest) in the core regions of the body for enhanced reflection or conduction in those areas, and the size of the heat management elements may be the smallest (or the spacing between them may be the largest) in peripheral areas of the body. In some embodiments, the degree of coverage by the heat management elements may vary in a gradual fashion over the entire garments as needed for regional heat management. Some embodiments may employ heat reflective elements in some areas and heat conductive elements in other areas of the garment.

[0045] In various embodiments, the heat management elements may be configured to help resist moisture buildup on the heat management elements themselves and further enhance the function of the base fabric (e.g. breathability or moisture wicking). In one embodiment, it has been found that reducing the area of individual elements, but increasing the density may provide a better balance between heat direction (e.g. reflectivity or conductivity) and base fabric functionality,

as there will be a reduced tendency for moisture to build up on the heat management elements. In some embodiments, it has been found that keeping the surface area of the individual heat management elements below 1 cm^2 can help to reduce the potential for moisture build up. In various embodiments, the heat management elements may have a maximum dimension (diameter, hypotenuse, length, width, etc.) that is less than or equal to about 1 cm. In some embodiments, the maximum dimension may be between 1-4 mm. In other embodiments, the largest dimension of a heat management element may be as small as 1 mm, or even smaller.

[0046] In some embodiments, the topographic profile of the individual heat management elements can be such that moisture is not inclined to adhere to the heat management element. For example, the heat management element may be convex, conical, fluted, or otherwise protruded, which may help urge moisture to flow towards the base fabric. In some embodiments, the surface of the heat management elements may be treated with a compound that may help resist the build up of moisture vapor onto the elements and better direct the moisture to the base fabric without materially impacting the thermal directing property of the elements. One such example treatment may be a hydrophobic fluorocarbon, which may be applied to the elements via lamination, spray deposition, or in a chemical bath.

[0047] In various embodiments, the heat management elements may be removable from the base fabric and reconfigurable if desired using a variety of releasable coupling fasteners such as zippers, snaps, buttons, hook and loop type fasteners (e.g. Velcro), and other detachable interfaces. Further, the base material may be formed as a separate item of body gear and used in conjunction with other body gear to improve thermal management of a user's body heat. For example, an upper body under wear garment may be composed with heat management elements in accordance with various embodiments. This under wear garment may be worn by a user alone, in which case conduction of body heat away from the user's body may typically occur, or in conjunction with an insulated outer garment which may enhance the heat reflectivity of the user's body heat.

[0048] In various embodiments, the heat management elements may be applied to the base fabric such that it is depressed, concave, or recessed relative to the base fabric, such that the surface of the heat management element is disposed below the surface of the base fabric. This configuration may have the effect of

improving, for example, moisture wicking, as the base fabric is the portion of the body gear or body gear lining that engages the user's skin or underlying clothing. Further, such contact with the base fabric may also enhance the comfort to the wearer of the body gear in applications where the skin is in direct contact with the base fabric (e.g. gloves, mittens, underwear, or socks).

[0049] **Figures 8-15** illustrate various views of a patterned heat management fabric used in a variety of body gear applications, such as a jacket (**Figures 8A-D**), boot (**Figure 9**), glove (**Figure 10**), hat (**Figure 11**), pants (**Figure 12**), sock (**Figure 13**), sleeping bag (**Figure 14**), tent rain fly (**Figure 15A**) and tent (**Figure 15B**). Each of the body gear pieces illustrated include a base material **20** having a plurality of heat management elements **10** disposed thereon.

[0050] While the principle embodiments described herein include heat management elements that are disposed on the inner surface of the base fabric, in various embodiments, the heat management material elements may be used on the outside of body gear, for instance to reflect or direct heat exposed to the outside surface of the gear. For instance, in some embodiments, base fabric and heat reflective elements, such as those illustrated in **Figures 1B-3E**, may be applied to an outer or exterior surface of the body gear, such as a coat, sleeping bag, tent or tent rain fly, etc in order to reflect heat away from the user.

[0051] In some embodiments, the body gear may be reversible, such that a user may determine whether to use the fabric to direct heat toward the body or away from the body. An example of such reversible body gear is illustrated in **Figure 15A**. In this embodiment, the heat management elements may be included on one side of a tent rain fly. In one embodiment, the rain fly may be used with the heat management elements facing outward, for example in hot weather or sunny conditions, in order to reflect heat away from the body of the tent user. Conversely, in cold weather conditions, for example, the tent rain fly may be reversed and installed with the heat management elements facing inward, toward the body of a user, so as to reflect body heat back toward the tent interior. Although a tent rain fly is used to illustrate this principle, one of skill in the art will appreciate that the same concept may be applied to other body gear, such as reversible jackets, coats, hats, and the like. **Figure 15B** illustrates an example wherein at least a portion of the tent body includes a fabric having a plurality of heat management elements disposed thereon. In the illustrated embodiment, the heat reflective elements are facing

outward and may be configured to reflect heat away from the tent and thus away from the body of the tent user. In other embodiments, the elements may be configured to face inward.

[0052] Although certain embodiments have been illustrated and described herein, it will be appreciated by those of ordinary skill in the art that a wide variety of alternate and/or equivalent embodiments or implementations calculated to achieve the same purposes may be substituted for the embodiments shown and described without departing from the scope of the present invention. Those with skill in the art will readily appreciate that embodiments in accordance with the present invention may be implemented in a very wide variety of ways. This application is intended to cover any adaptations or variations of the embodiments discussed herein. Therefore, it is manifestly intended that embodiments in accordance with the present invention be limited only by the claims and the equivalents thereof.

Claims

I claim the following:

1. A heat management material adapted for use with body gear, comprising:
 - a base material having a transfer property that is adapted to allow, impede, and/or restrict passage of a natural element through the base material;
 - an array of heat-directing elements coupled to a first side of the base material, the heat directing elements being positioned to direct heat in a desired direction, and wherein a spacing of the heat-directing elements helps enable the base material to perform the element transfer property,
 - wherein the base material comprises an innermost layer of the body gear having an innermost surface, and wherein the heat-directing elements are positioned on the innermost surface to direct heat towards the body of a body gear user.
2. The heat management material of claim 1, wherein the natural element is selected from the group consisting of: air, moisture, water vapor, and heat.
3. The heat management material of claim 1, wherein the base material is a moisture-wicking fabric.
4. The heat management material of claim 1, wherein the base material comprises one or more insulating or waterproof materials.
5. The heat management material of claim 1, wherein the base material is coupled to an insulating or waterproof material disposed on an opposite side as the heat management elements.

6. The heat management material of claim 1, wherein a surface area ratio of heat-directing elements to base material is from about 7:3 to about 3:7.
7. The heat management material of claim 6, wherein a surface area ratio of heat-directing elements to base material is from about 3:2 to about 2:3.
8. The heat management material of claim 1, wherein the heat-directing elements comprise a metal or metal alloy.
9. The heat management material of claim 8, wherein the heat-directing elements comprise aluminum to enhance heat reflectivity or copper to enhance heat conductivity.
10. The heat management material of claim 1, wherein the heat-directing elements have a maximum dimension of less than about 1 cm.
11. The heat management material of claim 1, wherein the heat-directing elements are treated with a hydrophobic material to resist moisture build up on the heat-directing elements.
12. The heat management material of claim 1, wherein the heat-directing elements have a maximum spacing of less than about 1 cm.
13. The heat management material of claim 1, wherein the heat-directing elements have a minimum spacing of more than about 1 mm.

14. The heat management material of claim 1, wherein the material is part of an item selected from the group consisting of: a coat, a jacket, a shoe, a boot, a slipper, a glove, a mitten, a hat, a scarf, pants, a sock, a tent, a rain fly, and a sleeping bag.

15. The heat management material of claim 1, wherein the heat-directing elements are concave or convex.

16. The heat management material of claim 1, wherein the heat-directing elements are recessed into the base material such that an outer surface of the heat directing element is below a surface of the base material.

17. A method of making a heat management body gear material, comprising:

coupling an array of heat-directing elements to a base material having a transfer functionality that is adapted to allow, impede, and/or restrict passage of a natural element through the base material, the heat directing elements being positioned to direct heat in a desired direction;

pairing the heat management body gear material with a piece of body gear; and

providing, with the material, body heat management and base material functionality;

wherein the base material comprises an innermost layer of the body gear having an innermost surface, and wherein coupling the array of heat-directing elements to the base material comprises positioning the array of heat directing elements on the innermost surface to direct heat towards the body of a body gear user.

18. The method of claim 17, wherein coupling the heat-directing elements comprises coupling heat-directing elements of a size and spacing to cover from about 30% to about 70% of the base material.

19. The method of claim 17, wherein coupling the heat-directing elements comprises coupling heat-directing elements such that there is a spacing of between about 2 mm and 1 cm between adjacent elements.

20. The method of claim 17, wherein the base material further provides insulating properties, and wherein the heat-directing material elements reflect heat toward a body of a user.

21. The method of claim 17, further comprising treating the heat-directing elements with a hydrophobic treatment that will resist moisture buildup on the heat directing elements.

22. The method of claim 17, wherein providing body heat management and base material transfer functionality includes:

providing the heat-directing elements adapted to reflect heat towards the wearer's body; and

providing the base material that includes one or more functional characteristics including air permeability, moisture wicking, and thermal permeability.

FIG. 1A

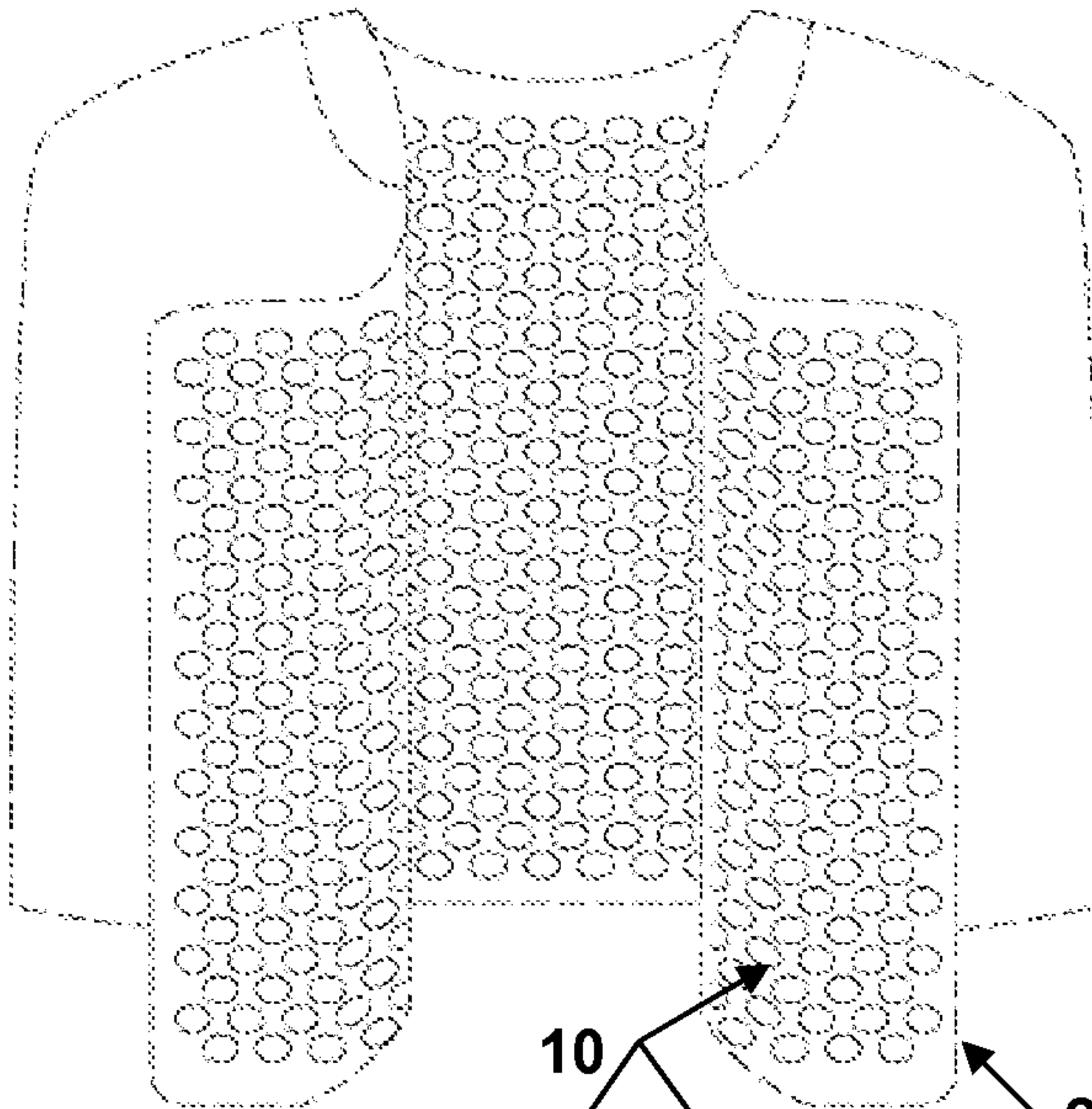

FIG. 1B

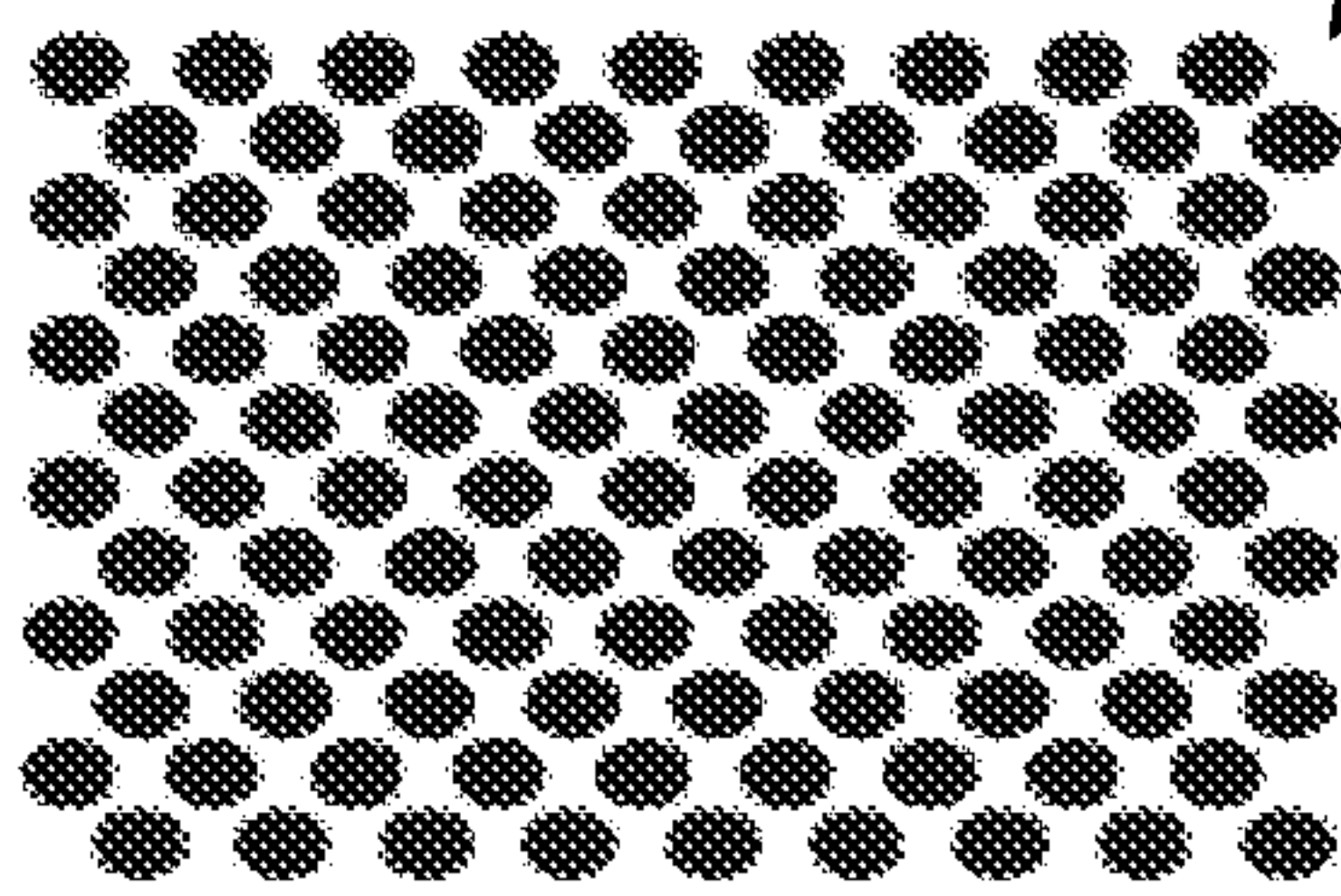

FIG. 1C

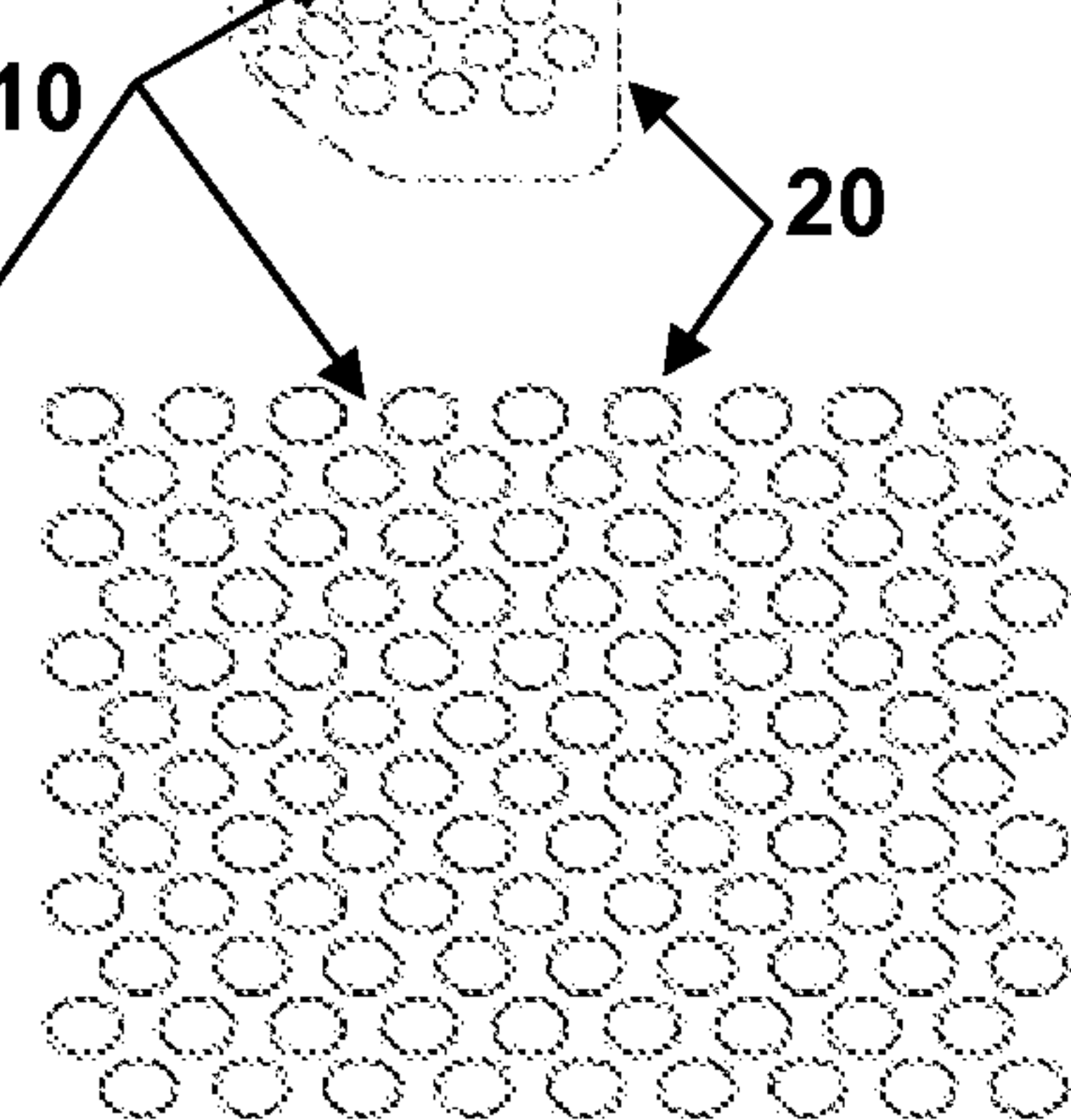

FIG. 1D

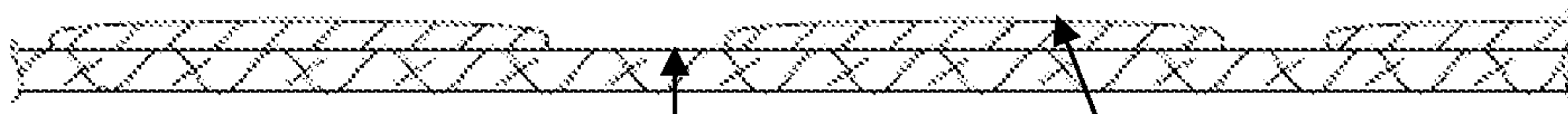
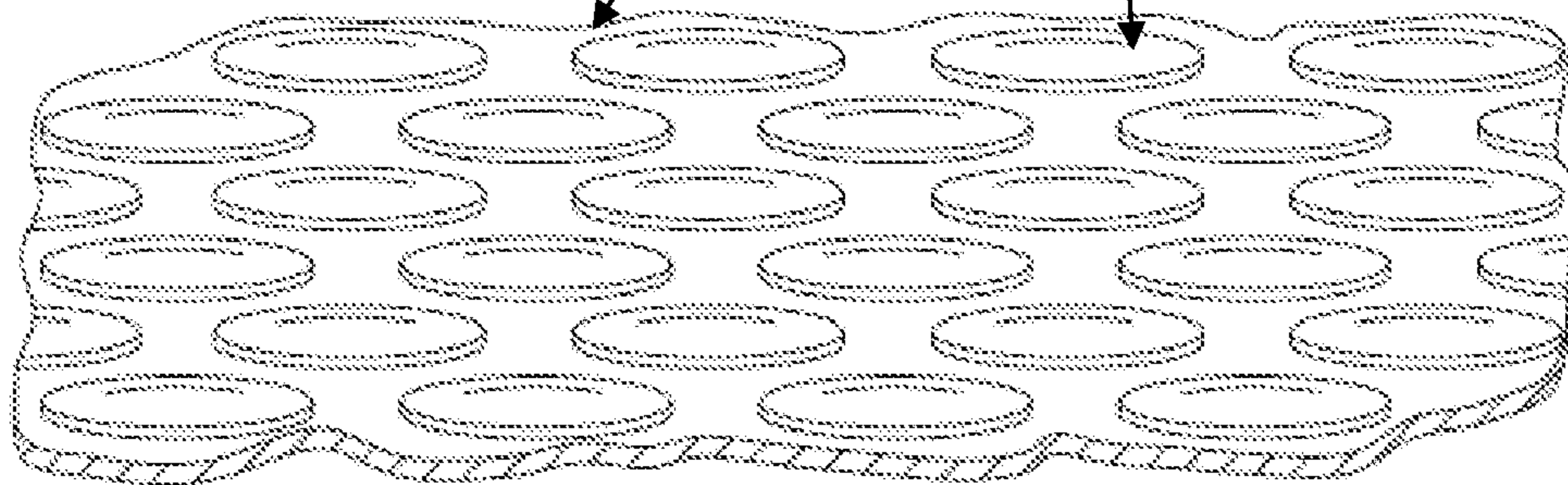

FIG. 1E



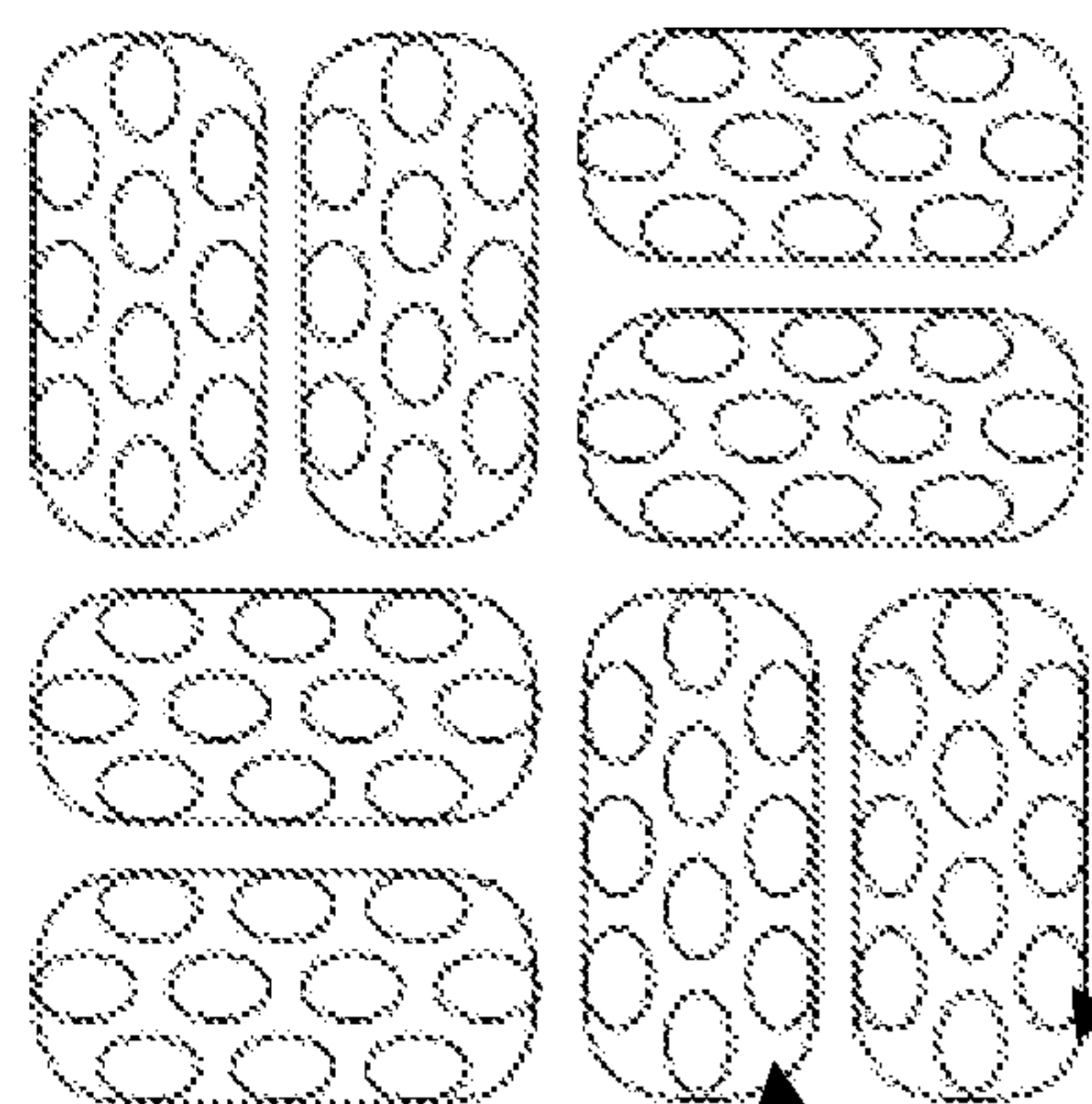

FIG. 2A

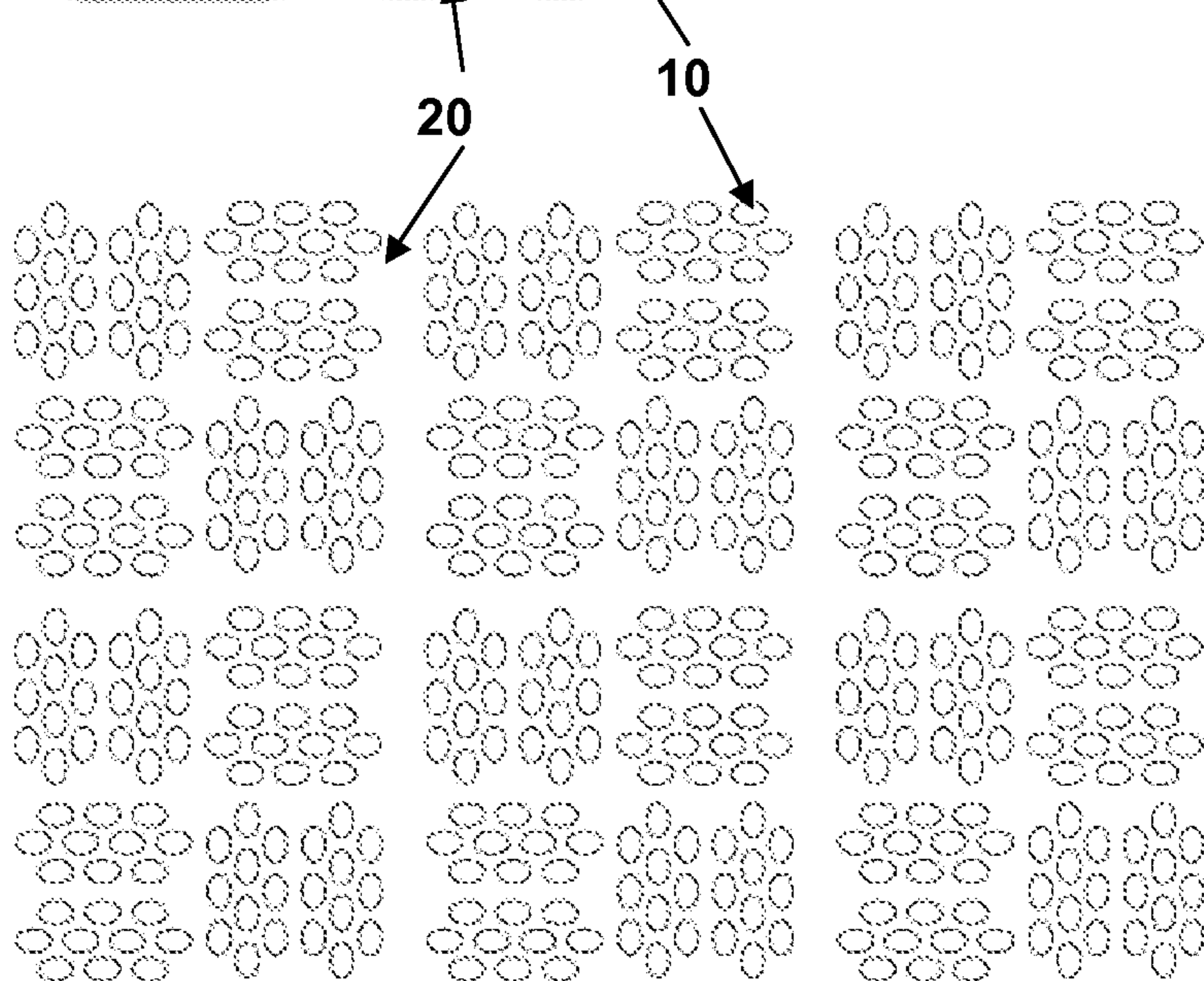

FIG. 2B

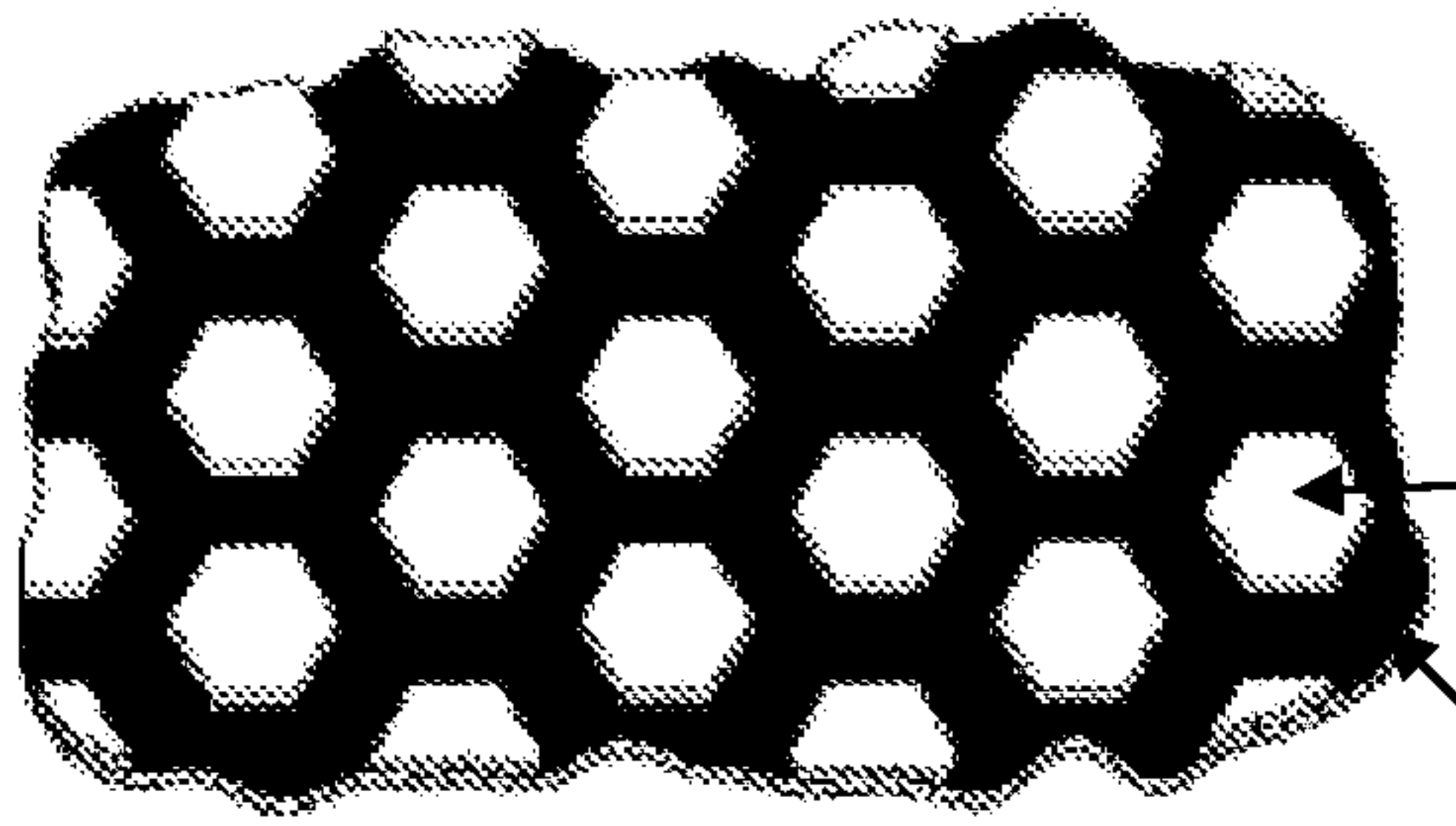

FIG. 3A

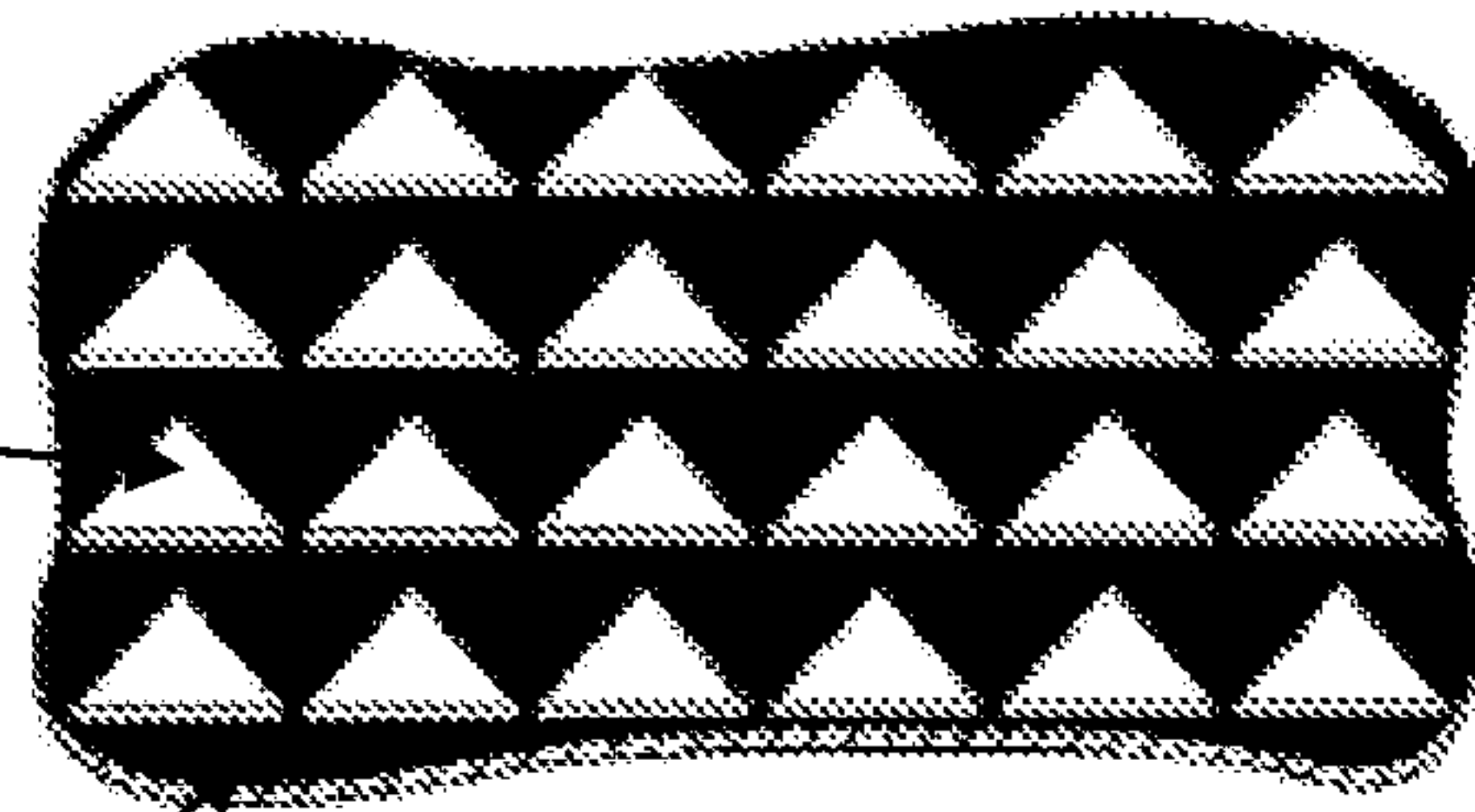

FIG. 3B

10

20

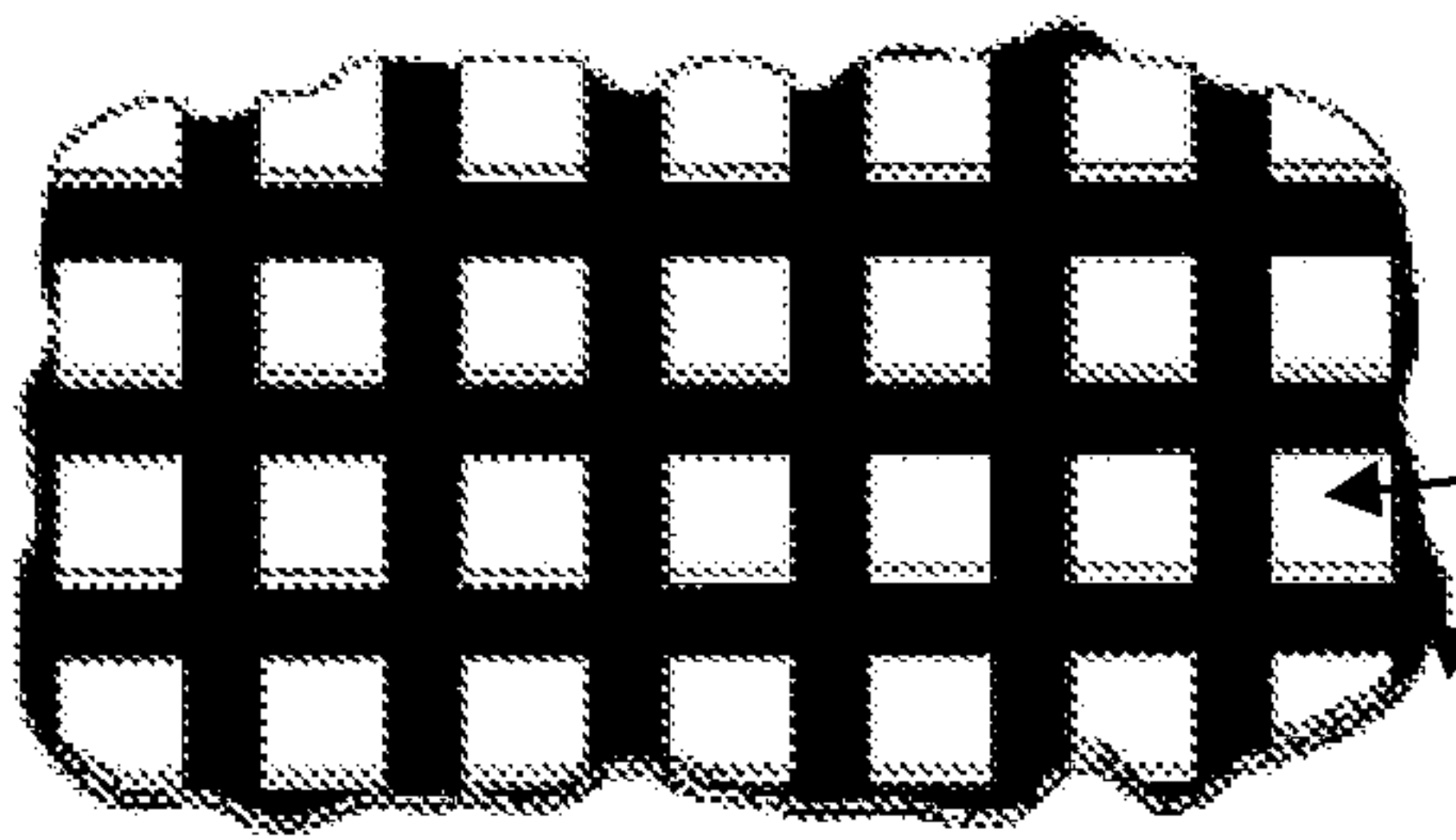

FIG. 3C



FIG. 3E

10

20

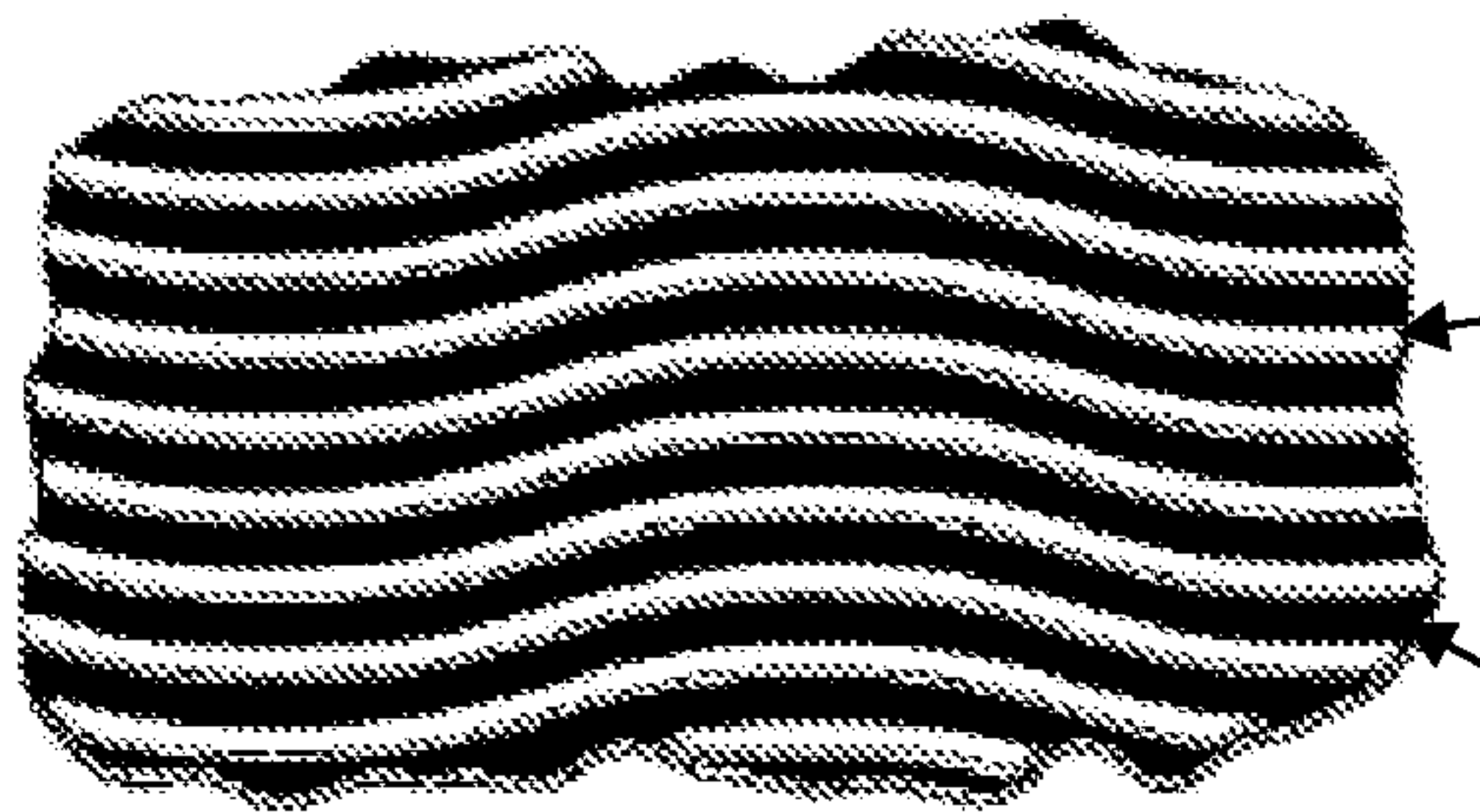

FIG. 3D

10

20

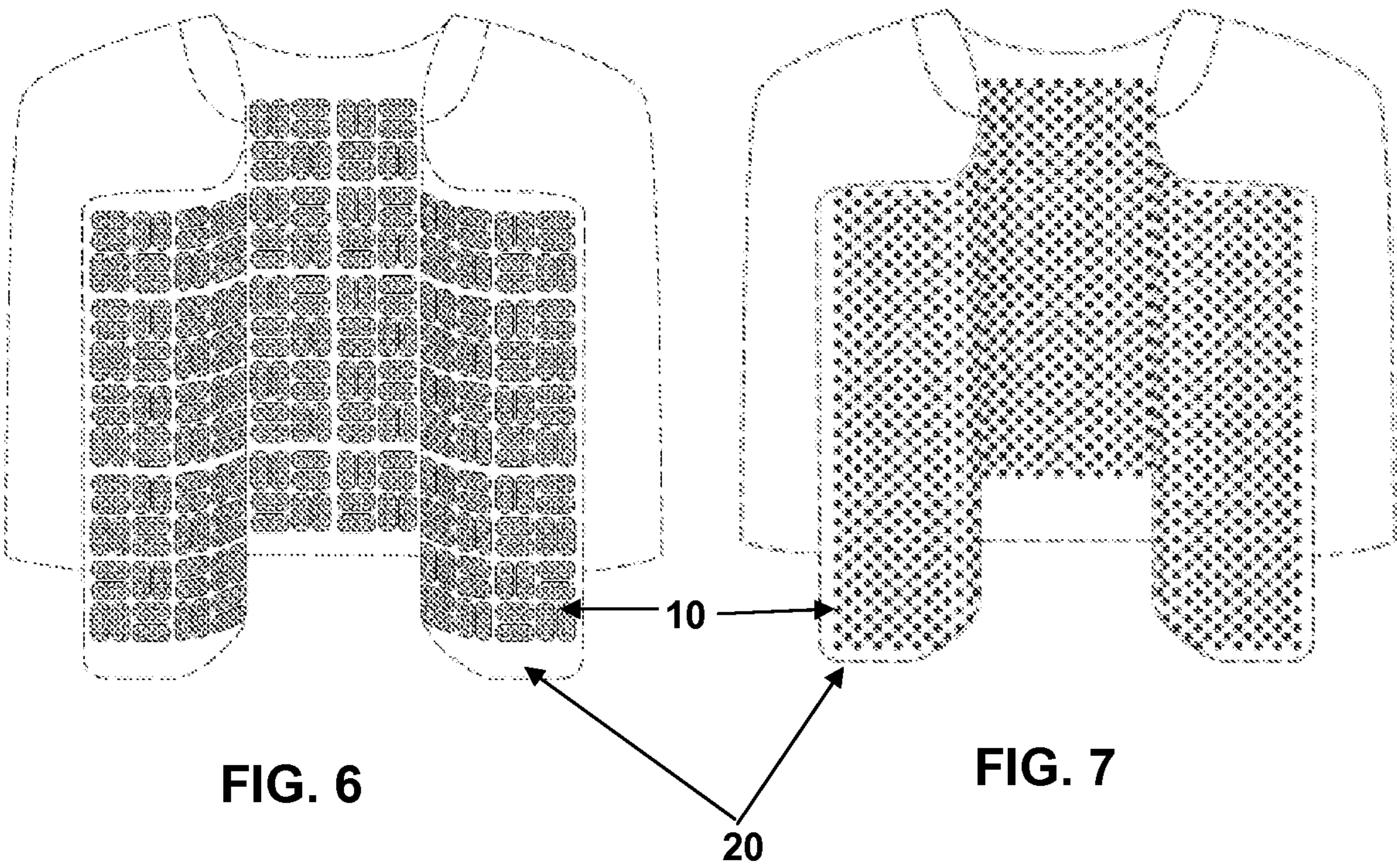
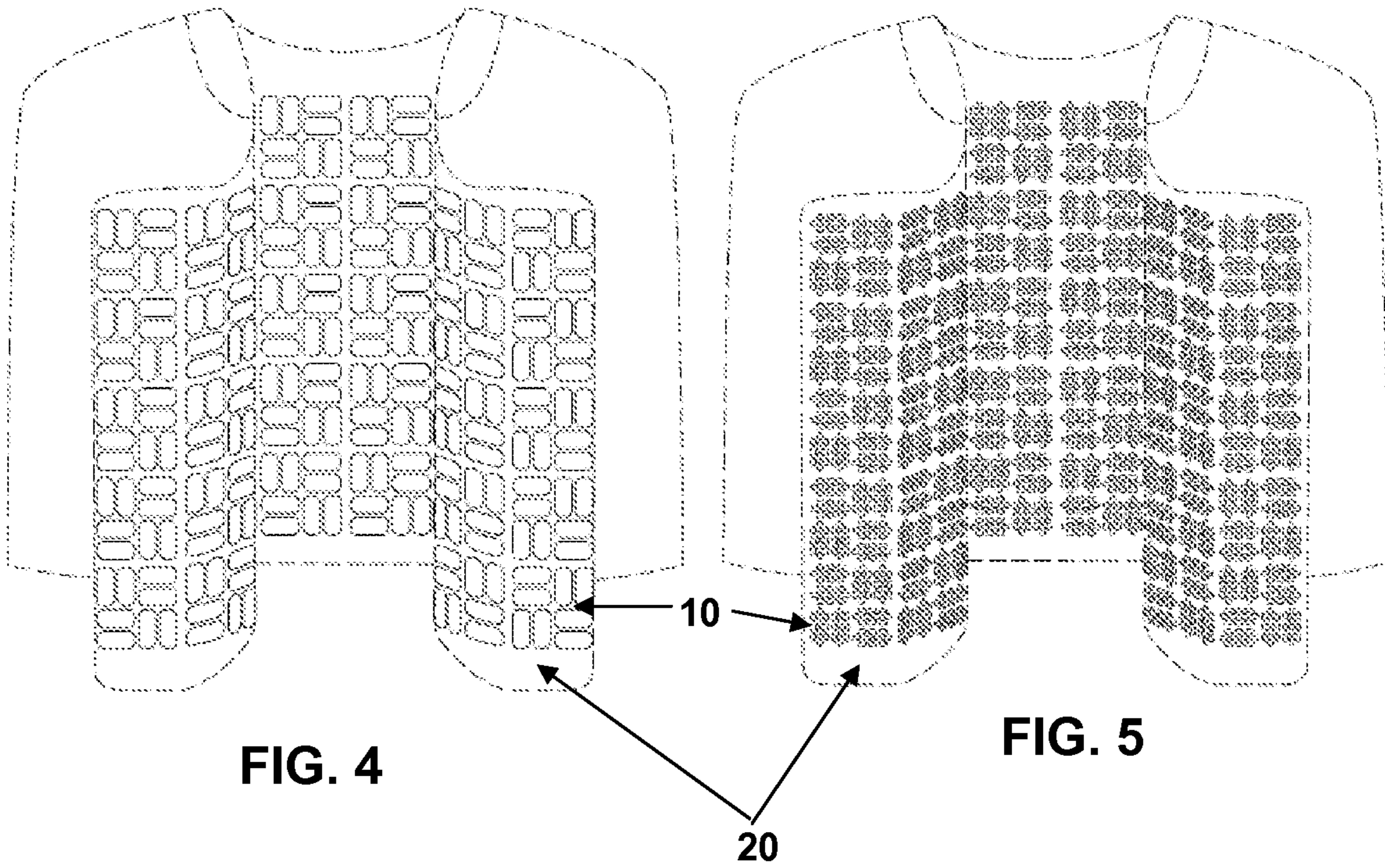

FIG. 8A

FIG. 8B

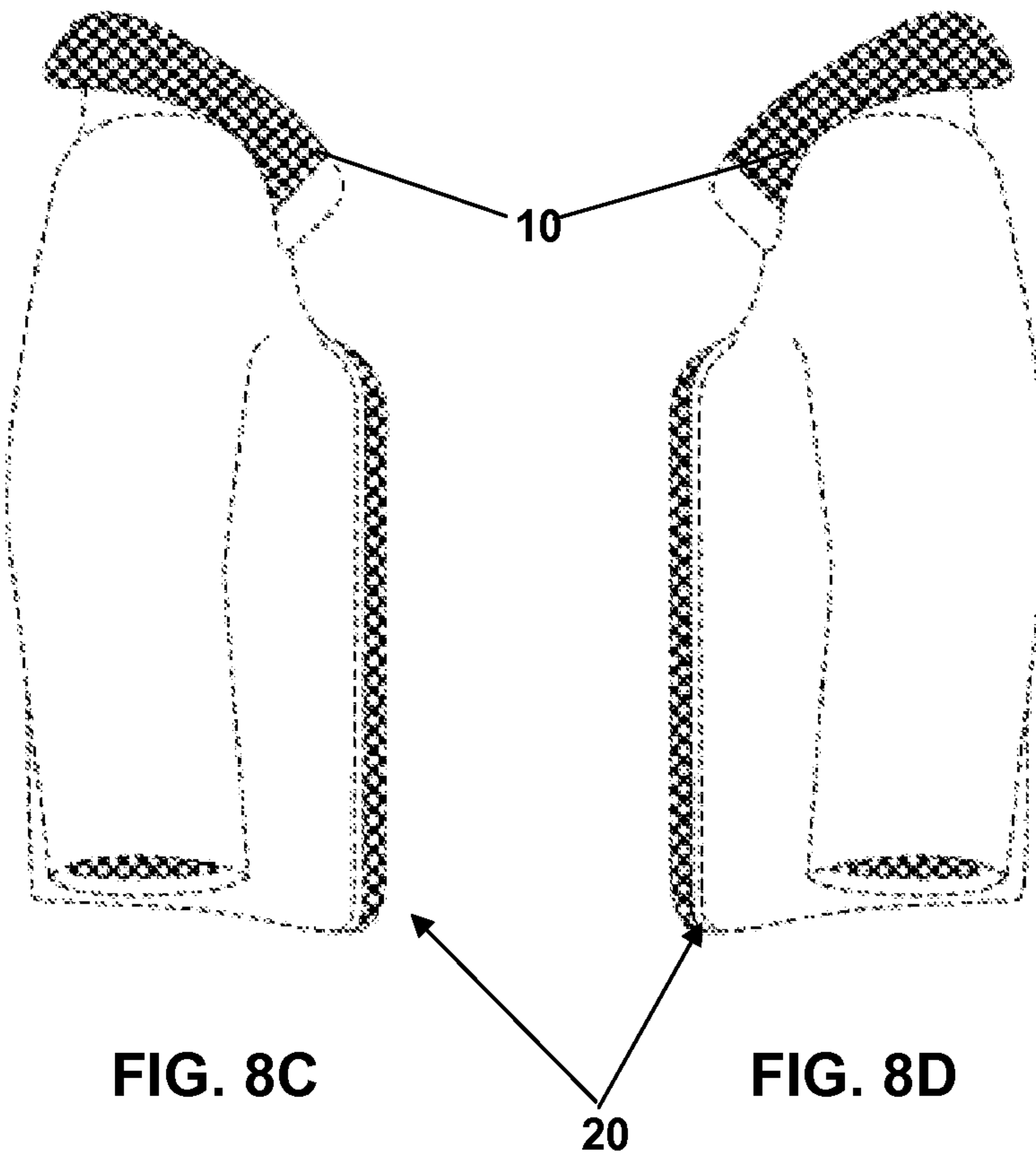
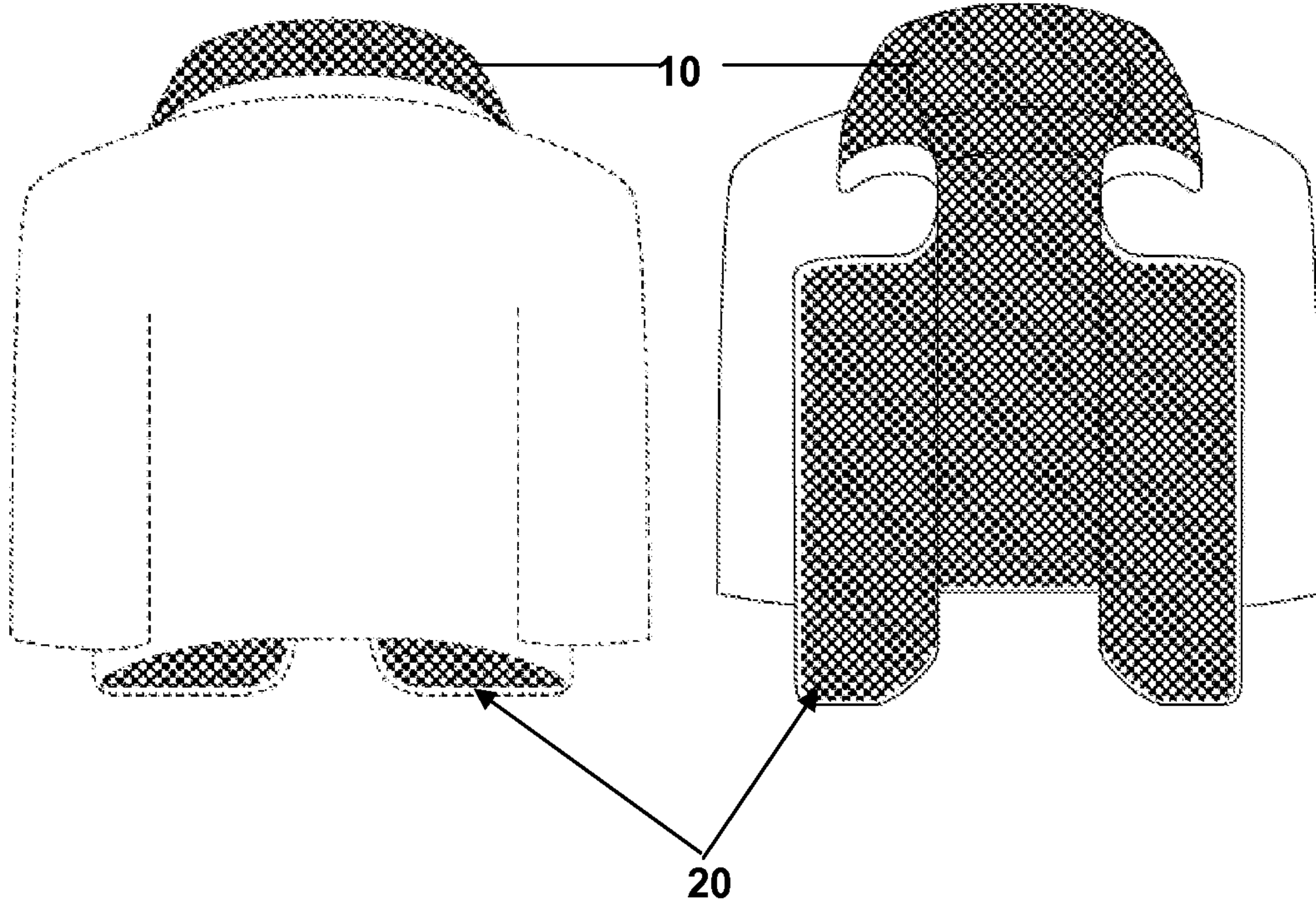
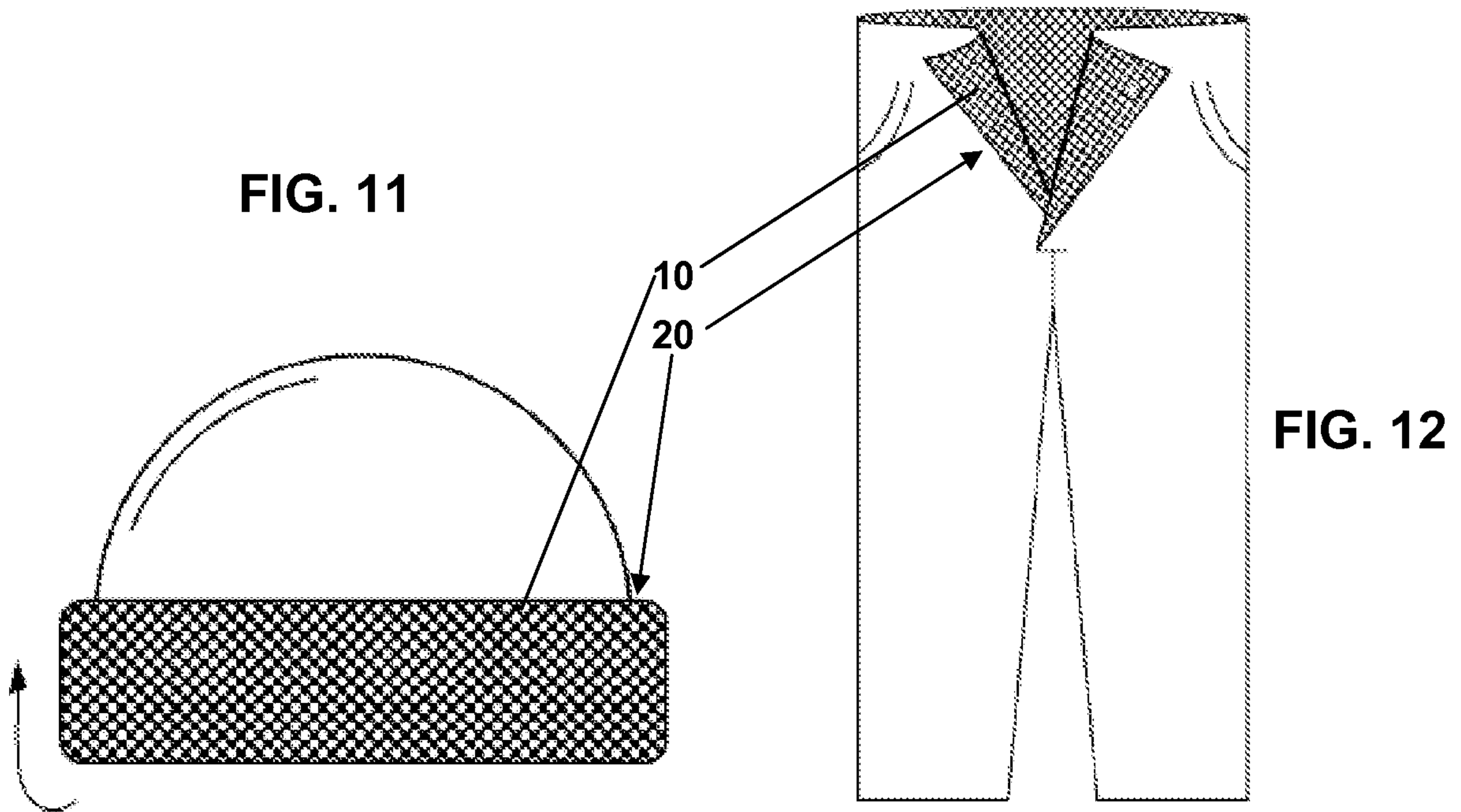
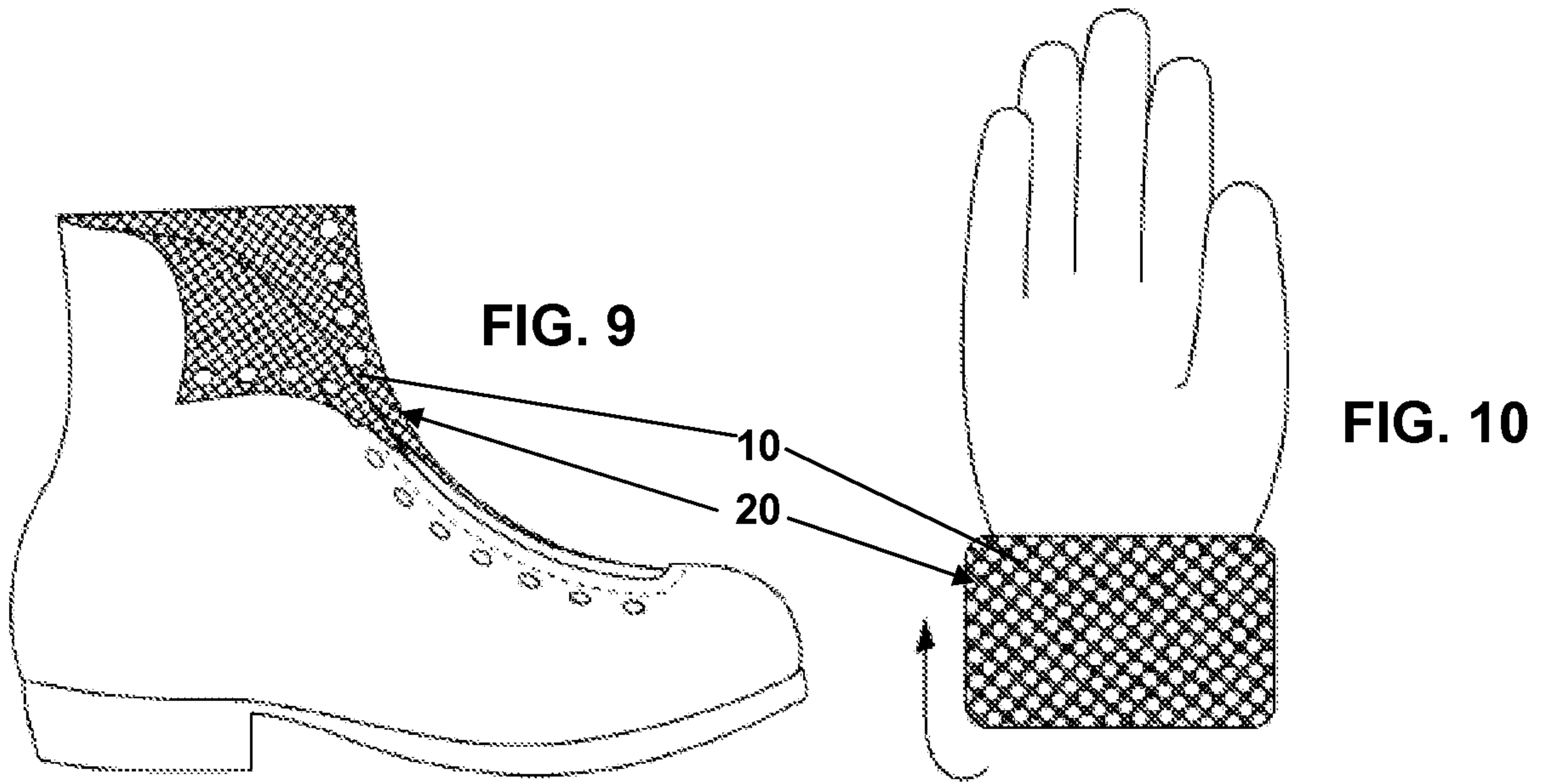

FIG. 8C

FIG. 8D



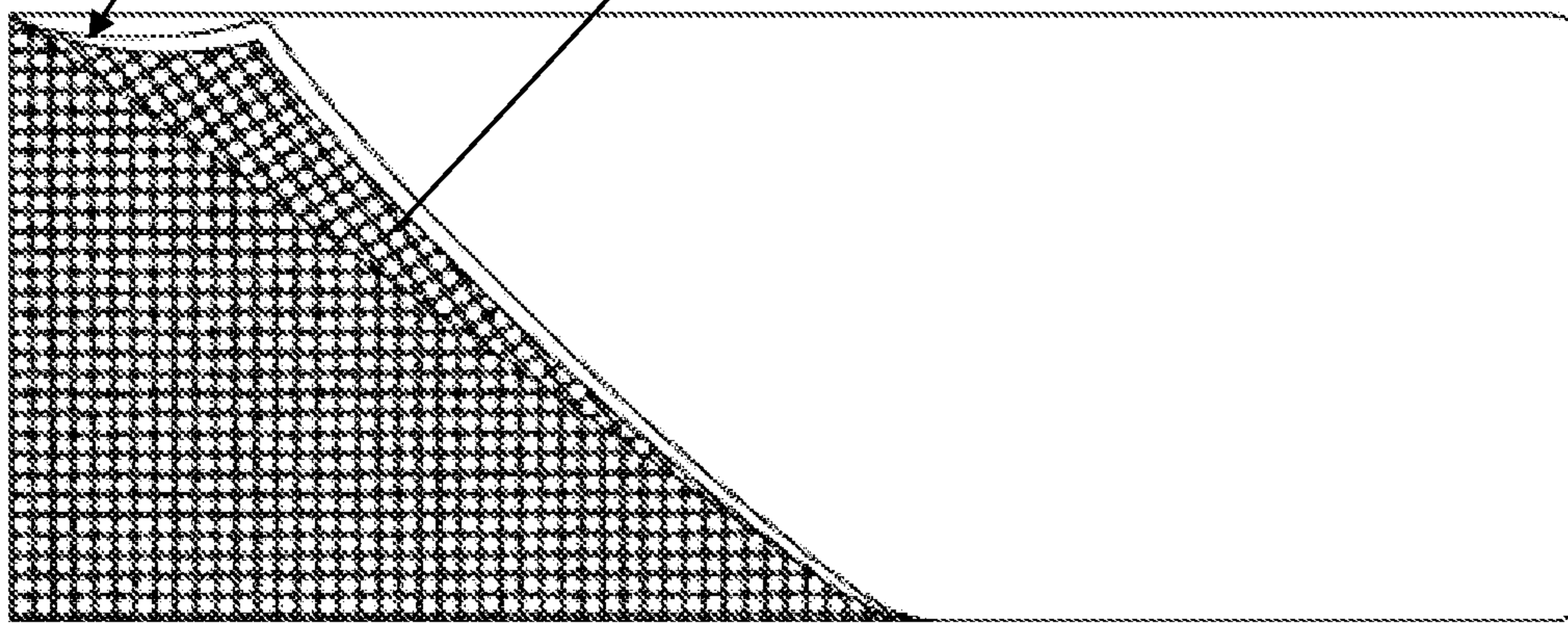
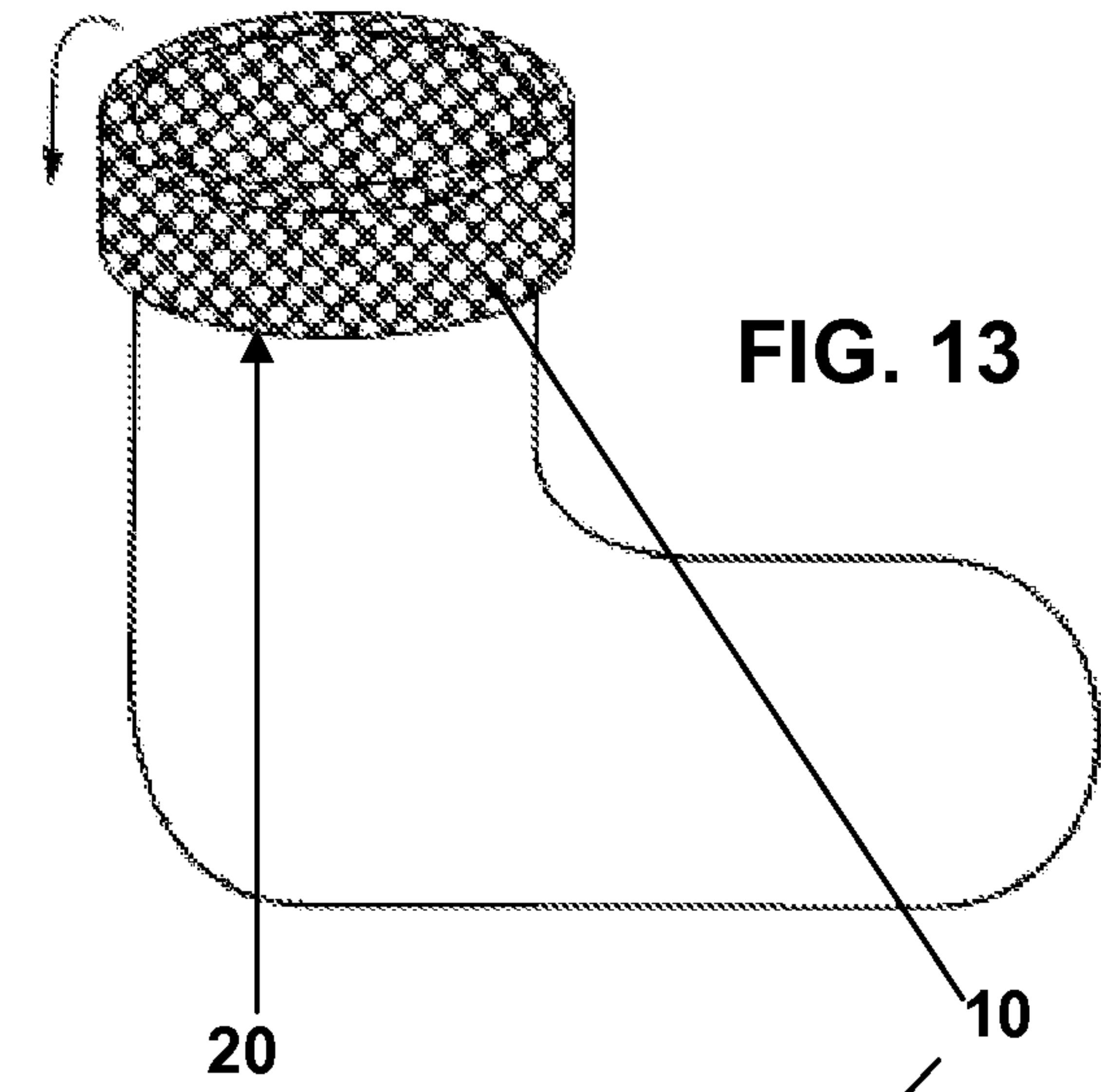
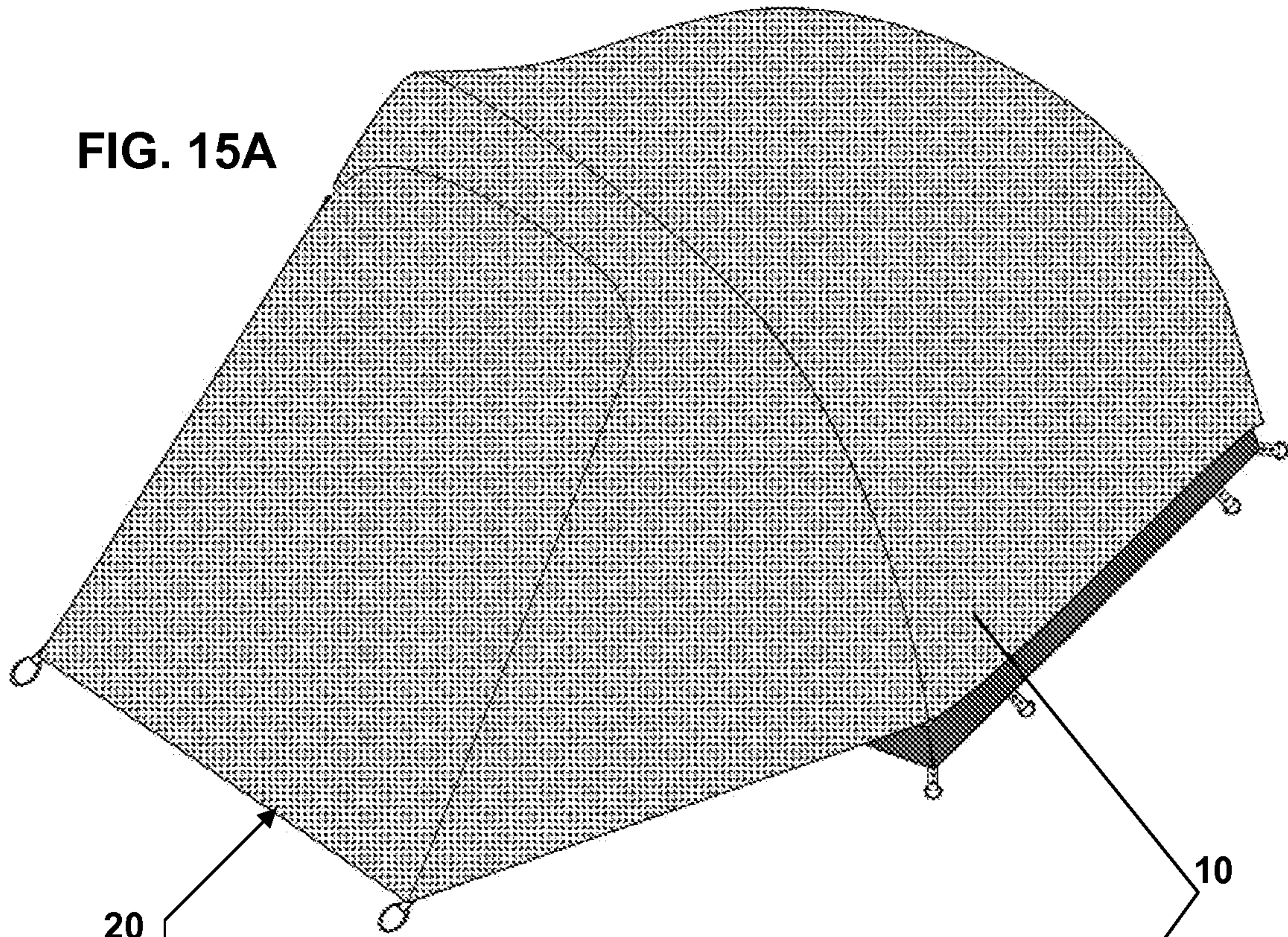

FIG. 15A



20

10

FIG. 15B

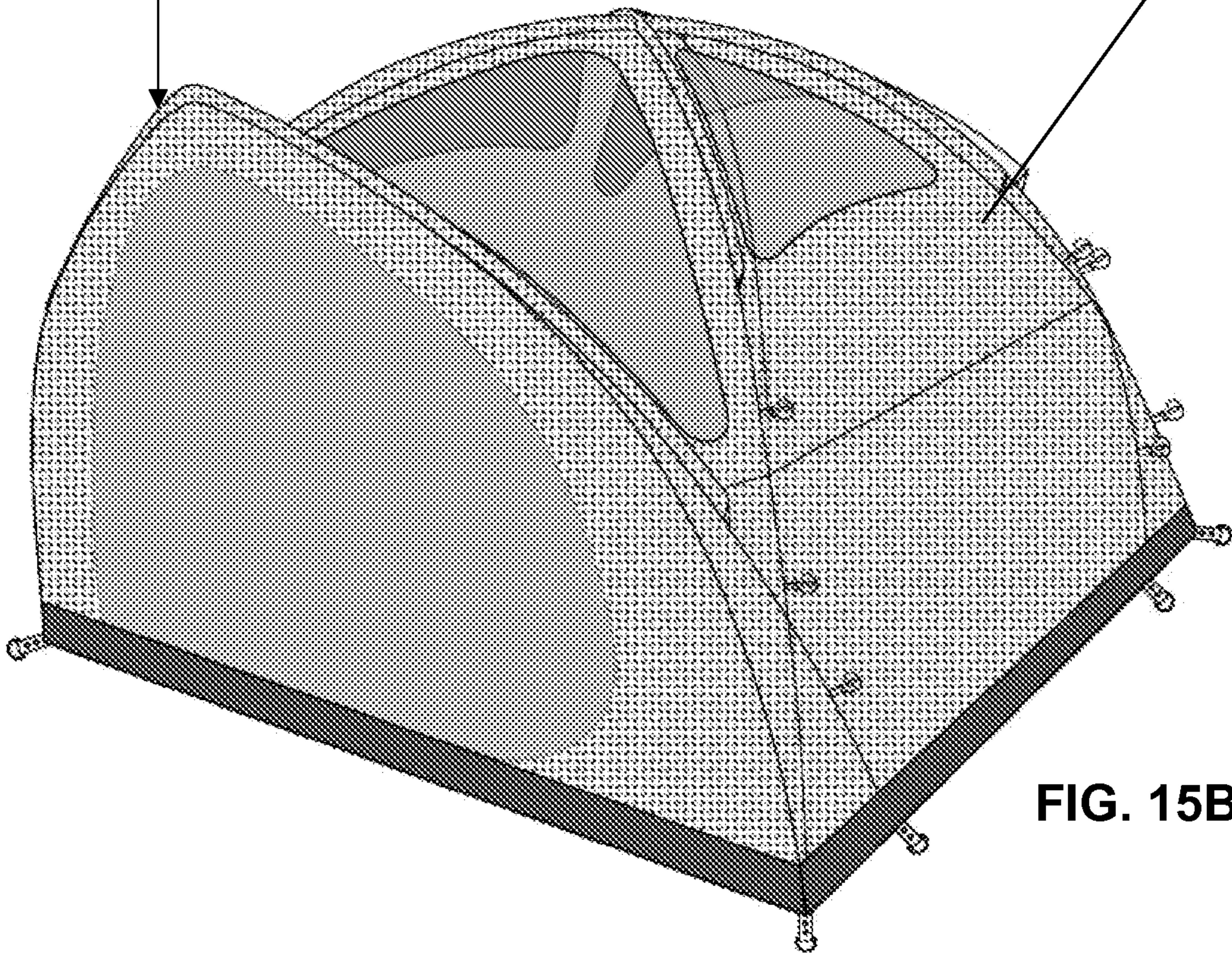

20

10

