

(19)  
(12)

(KR)  
(B1)

(51) 。 Int. Cl. <sup>6</sup>  
F16L 41/00

(45)  
(11)  
(24)

2001 09 28  
10 - 0282789  
2000 12 01

(21) 10 - 1998 - 0006873  
(22) 1998 03 03

(65) 1998 - 0079815  
(43) 1998 11 25

(30) 97 - 65461 1997 03 04 (JP)

(73) 가 가  
가 131 - 2

(72) 738 - 8

(74)

:

(54)

가 , 가 ,  
, ,  
, ,  
, 가 ,

1

2 1 , .

3 1 , .

4 1 , .

5

6 fp

7

8

9

10

11

< >

1 :

1 - 1 :

1 - 2 :

1 - 3 :

1 - 4 :

2 :

2 - 1 :

2 - 2 :

2 - 3 :

3 - 1 :

3 - 2 :

4 - 1 :

4 - 2 :

4 - 3 :

5 :

6 :

8 9 (boss type)  
 (11) (11 - 1) (11 - 4)  
 (12) (12 - 2) (12 - 3)  
 (13') (13" )  
 (11) (11 - 3)  
 (12 - 3) (11) (11 - 4) (13')  
 (13" ) (11 - 3)  
 (12 - 2) (neck) 8 9  
 12 - 1 (12) 14' 14"

10  
 (11) (11 - 1) (11 - 4)  
 (11) (12 - 3) (15) (12)  
 (12 - 2) (11 - 3) (11) (11 - 4)  
 11 - 4) (15) (13') 가  
 (12 - 2)

11  
 (11) (11 - 1) (11 - 2)  
 (12) (12 - 2) (11 - 1) (11 - 4) (12)  
 12 - 3) (11 - 1) (11) (16)  
 - 3) (16) (16 - 1)



가

가

가

가

1 - 7 , 1 , 2 , 3 - 1  
3 - 2 , 4 - 1 , 4 - 2 , 4 - 3

4) , (1) 가 , 28mm 9mm (1  
1) (1 - 2) , (1 - 1) (1 - 3) (1 -

1 - 2) , (1) 가 , (1 - 1) (  
(1 - 5) (1) (102) (1 - 2)  
가

1 - 4 (1 - 2)  
(1 - 5) , (1) (1 - 4)  
(1) 가 (1)  
(1 - 4) 가 (1) 가 , (1 - 4)

(1) (1 - 1) (1 - 5)

(1 - 5) 0.05~1.0mm , 1.0~2.0mm  
가 0.05mm , 가  
가 2.0mm , 가

(2) (1) (1 - 1) (2)  
- 1) (2) (2) (2 - 2) (2 - 3) 1 (1 - 1)  
(2) (2 - 2) (2 - 3) (1) (1 - 1)  
3) (4 - 1) (2 - 2) 가 (4 - 1) (3 - 1)가 (1 - 1)  
(1 - 4) (2 - 2) 가 (4 - 1) (2) (1 - 1)  
2 - 2) 2 3 (2 - 3) (1) (1 - 3) (4 - 1)  
- 2) (4 - 3) (2) 가 (4 - 2) (4 - 3) (3 - 2)가 (1 - 4)  
(2 - 2) 가 (4 - 2) (4 - 3)

4 (1 - 3)  
(1 - 2a) (1 - 4) (1 - 2) (1 - 3)  
(1 - 1) (1 - 3)

4 (2) (2 - 2)  
(2 - 3) (1) (1 - 3) (4 - 1)  
(4 - 1)가 (3 - 2)가 (4 - 1) (2 - 1)

5

, 28mm 9mm STS48  
(1) (1 - 1)가 (3 - 1)  
1) (5 - 1) (5) (2)

(5 - 1) (1)  
(5) (1) 가 가 (5)  
(5) (1) (1 - 1)  
(1 - 5)

(2-2) (2-3) (1) (1-3) (2)  
 (2) 가 (3-1) (3-1)가 (5) (2-)  
 2) 가 (3-1)  
 , 6 .

(1) 5 , , 28mm 9mm (1)  
 STS48 (2) (3-1)  
 -1) (6-1) (6) (1) (2-2) (2-3)  
 (1) (1-3) (2) (4-1) (2-2) 가  
 (3-1)가 (6) (6-1) (2-2)

(1-5)

fp

(1-5)

, 7

(1-2)

(1-5)

(1-5)

(1-2)

(2)

(1-2)

t)

가

(roo

(57)

1.

가

2.

1 가 가

3.

1 2 0.05 1.0mm

4.

3 1.0 2.0mm

5.

1 2

6.

1 2

7.

1 2

8.

1 2

9.

7 -



1

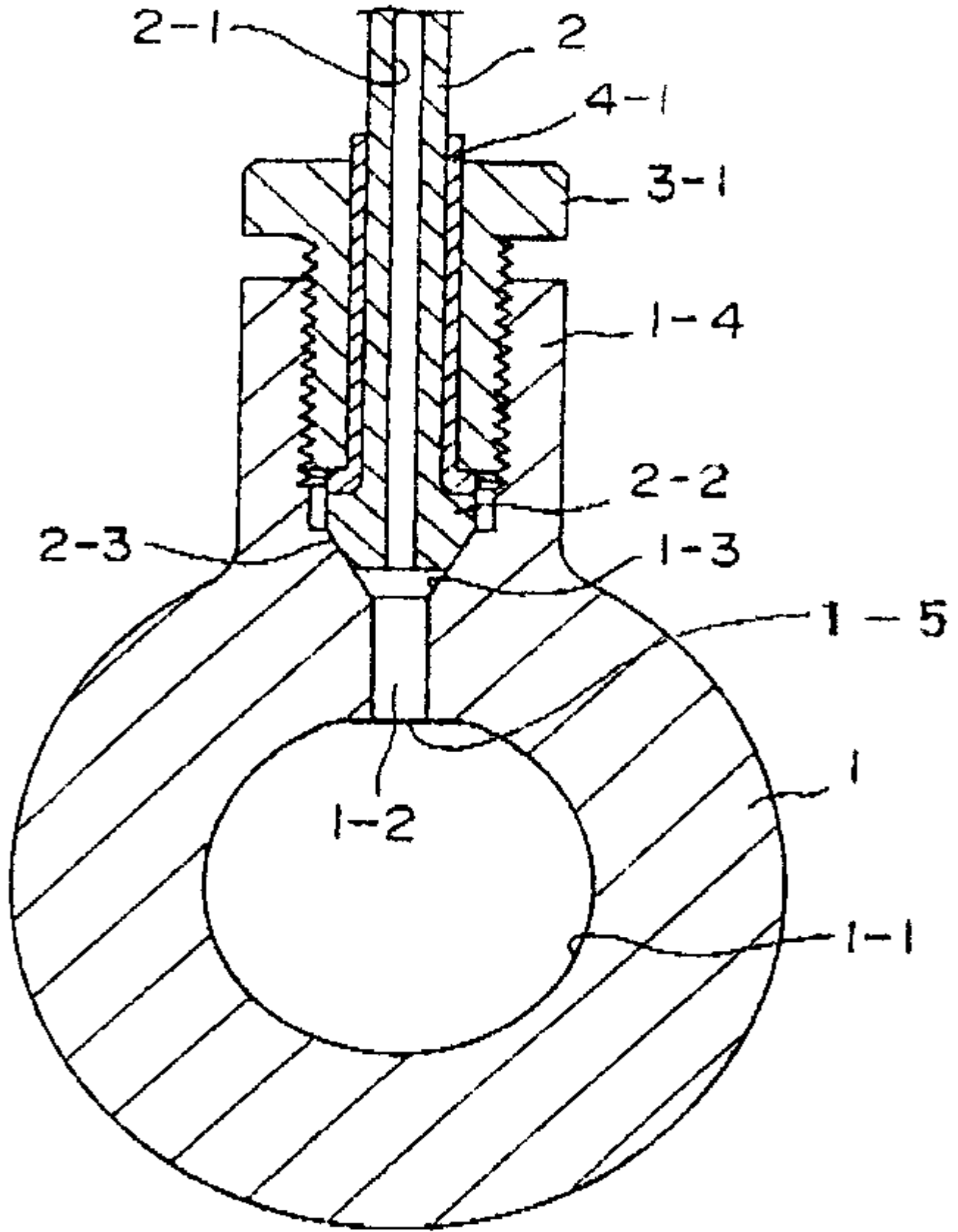

2

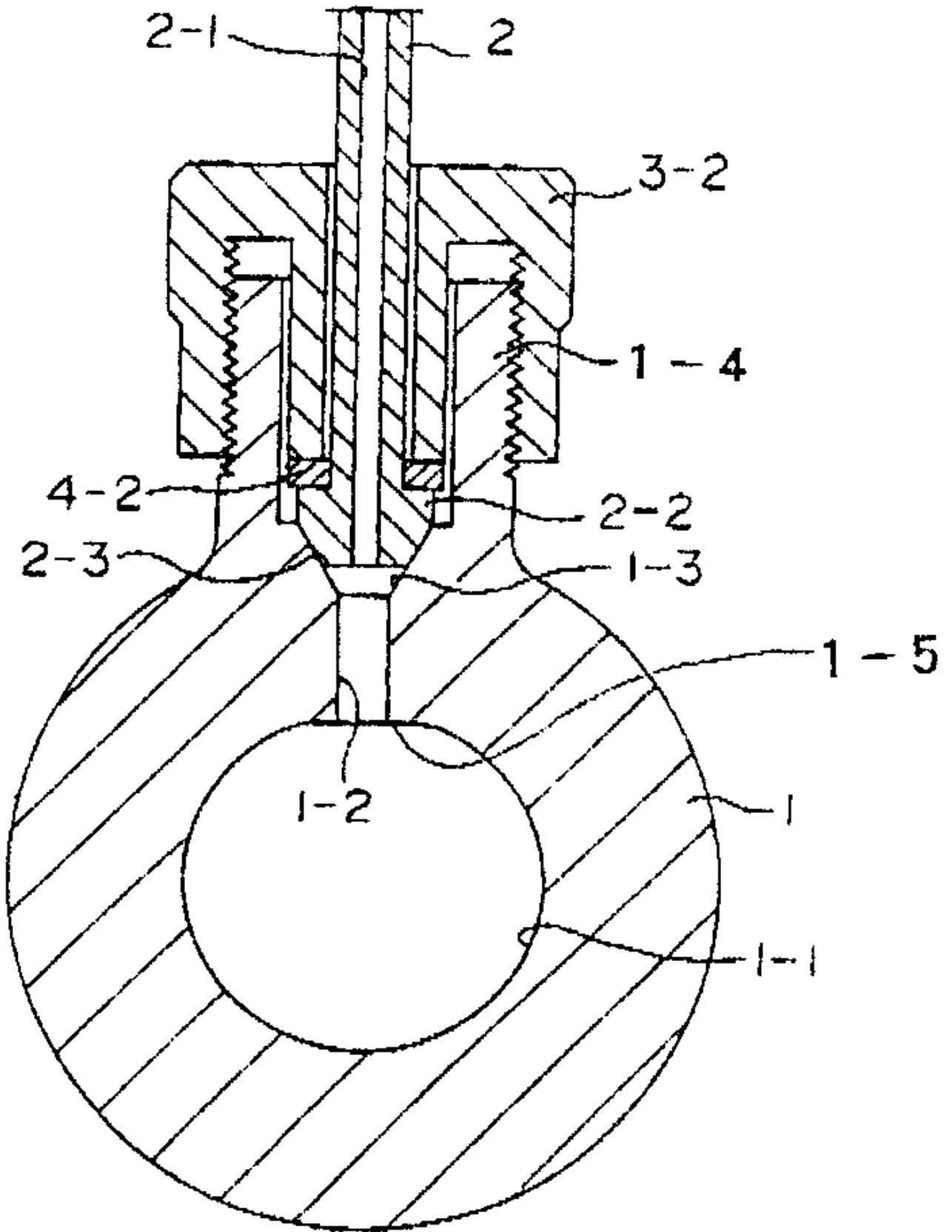

3

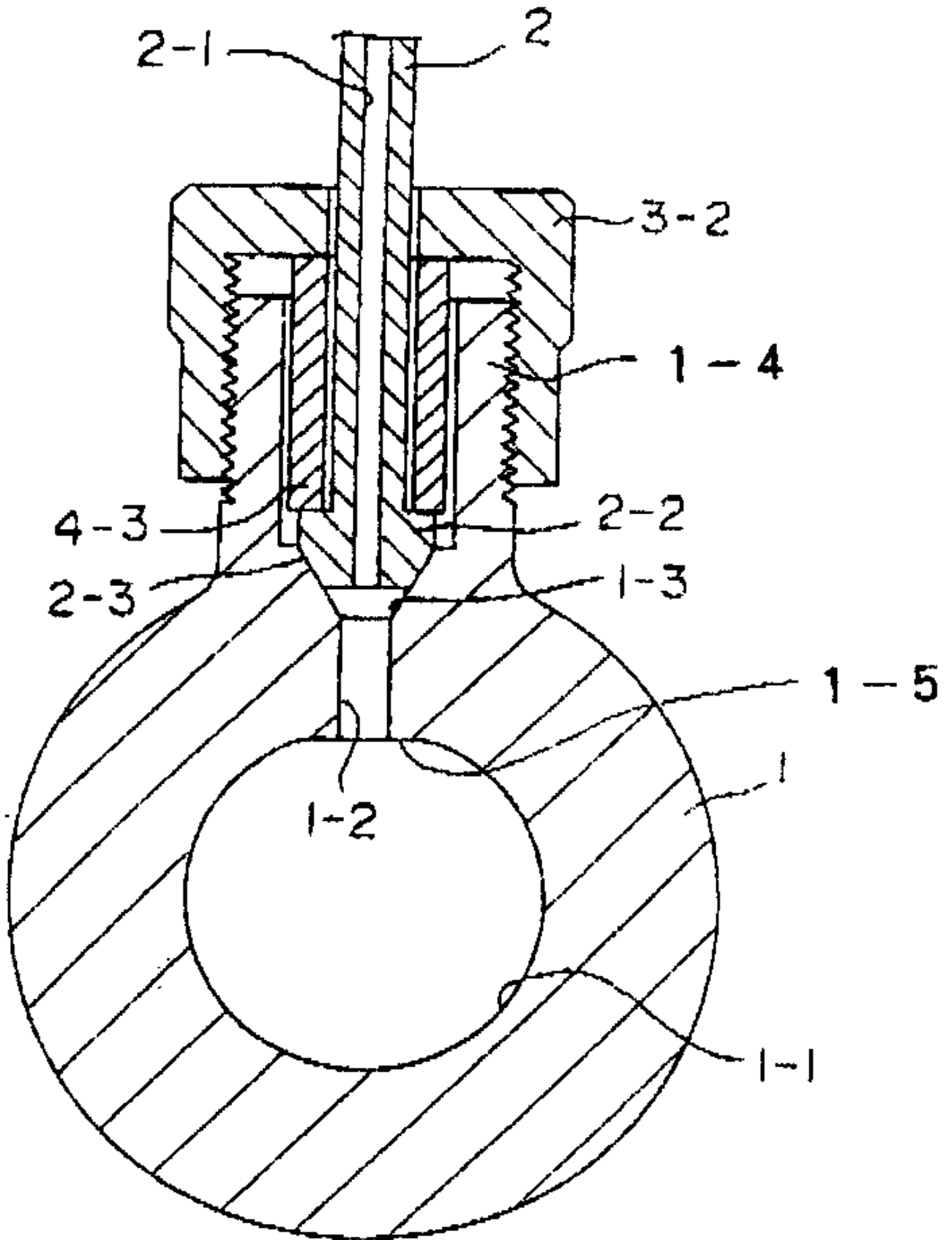

4

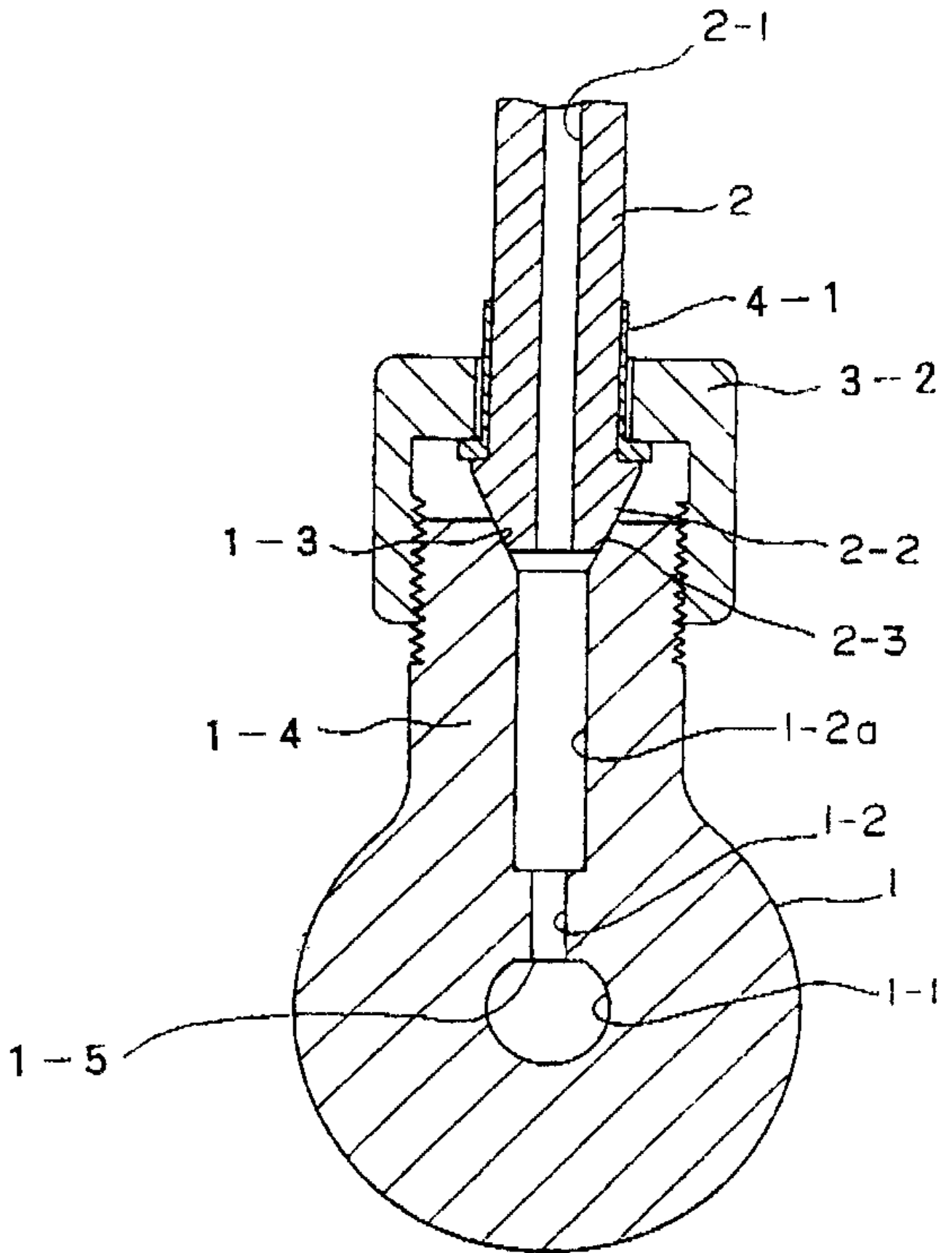

5

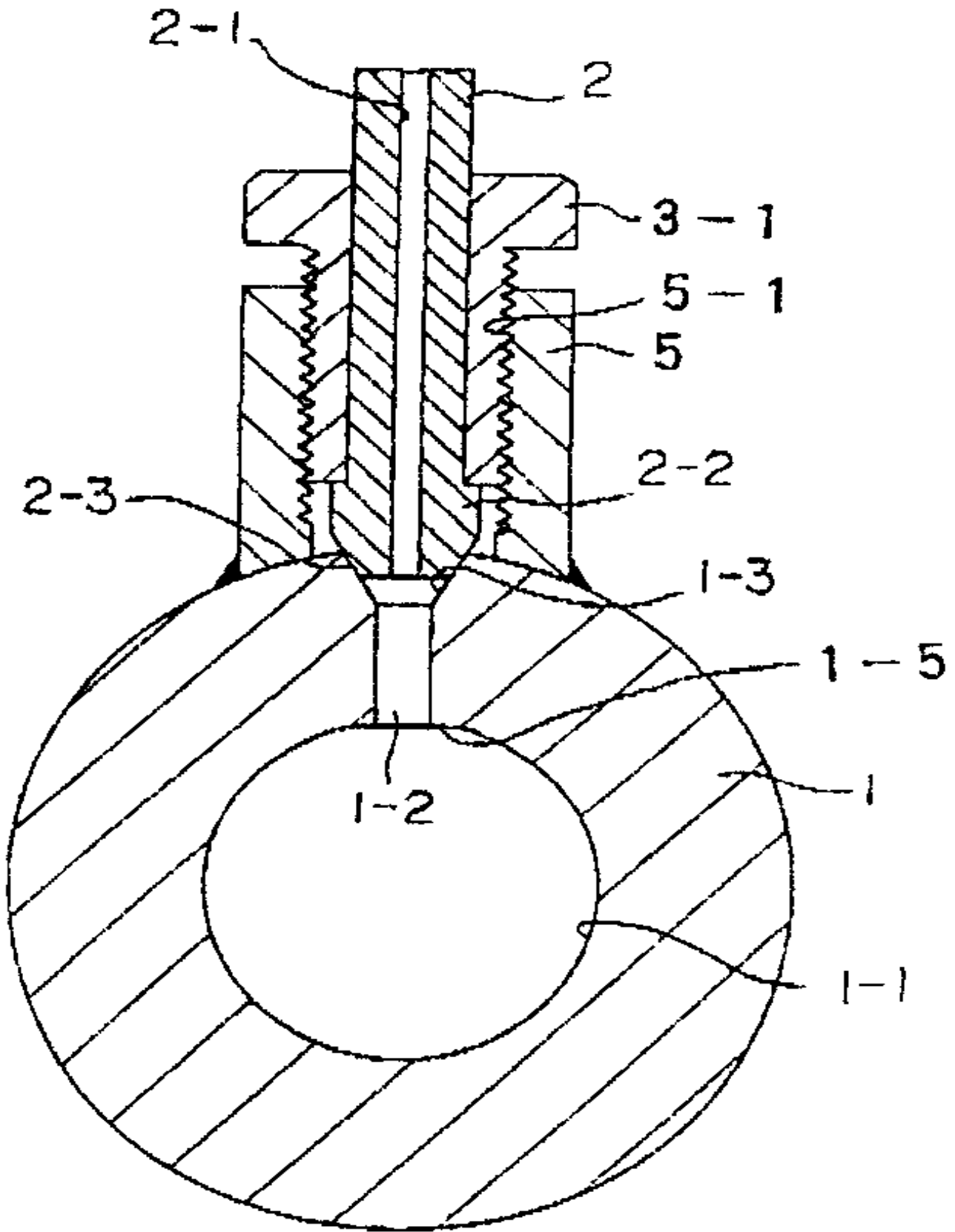

6

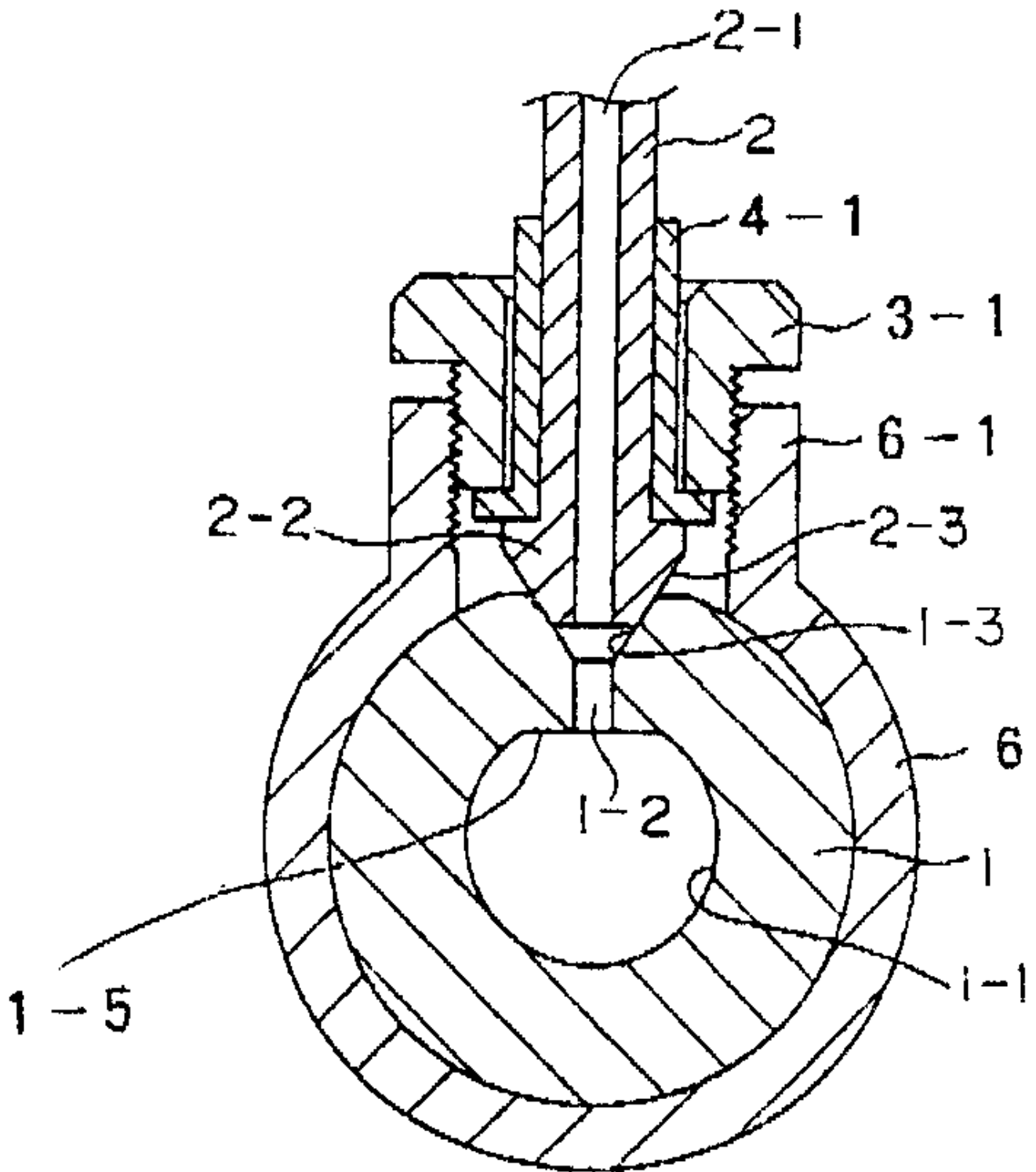

7

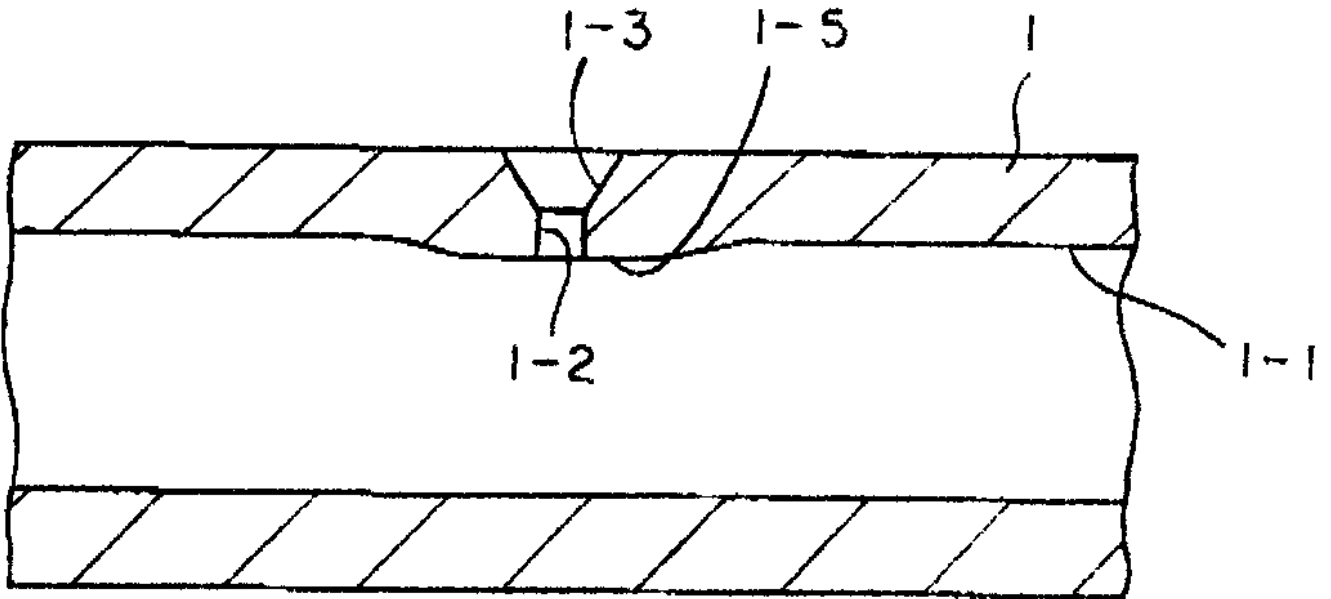

(종래 기술)

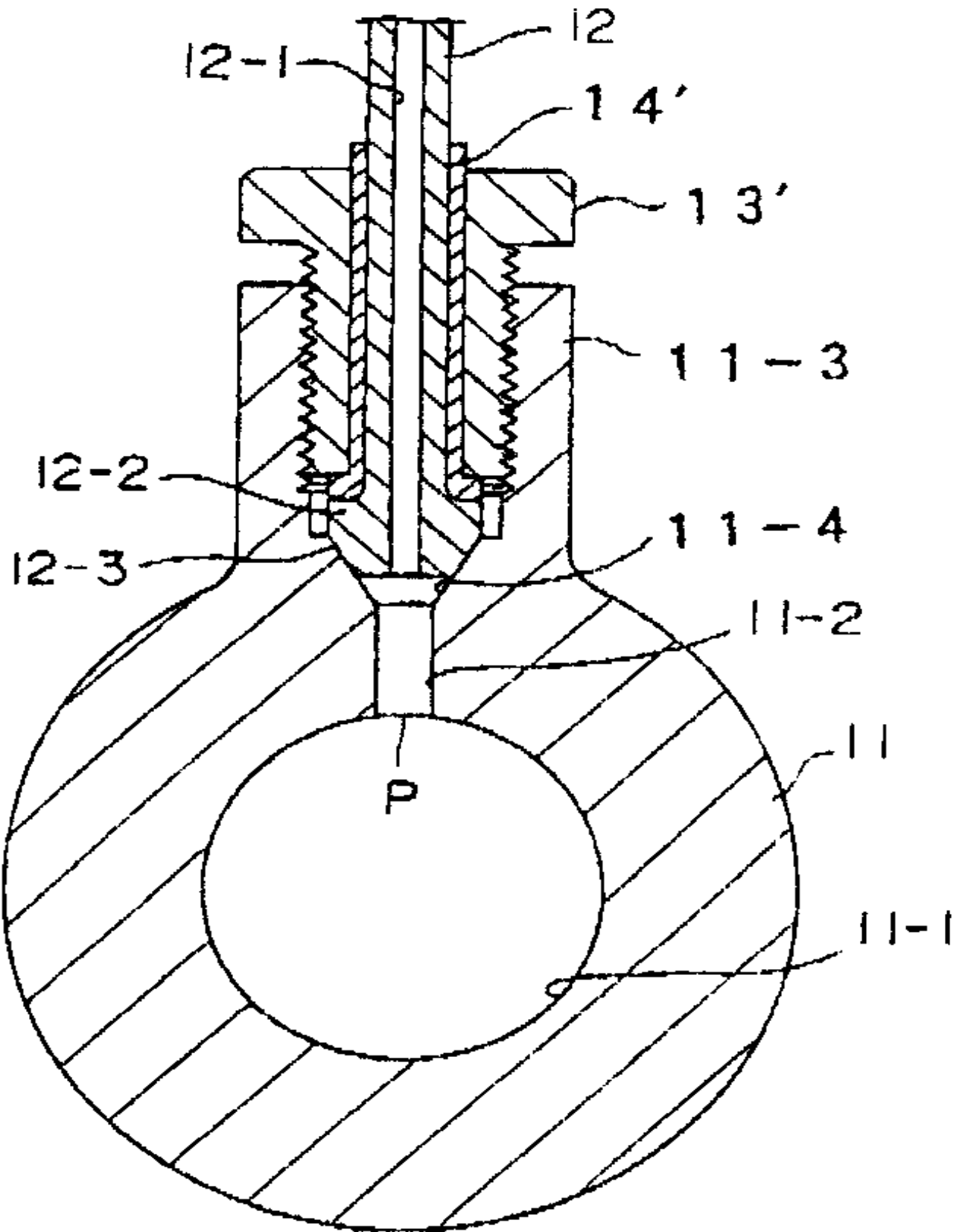



(종래 기술)

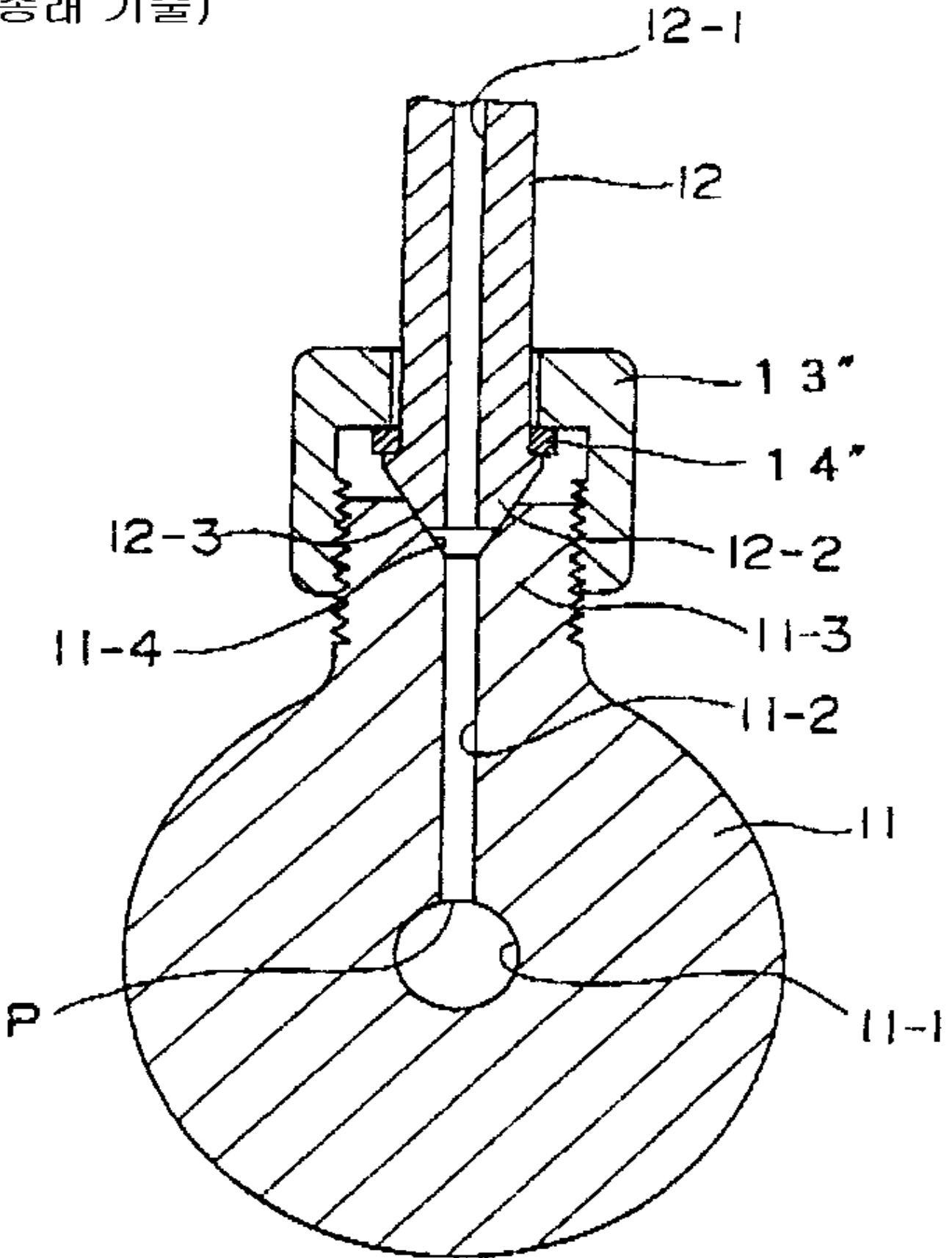

10

(종래 기술)

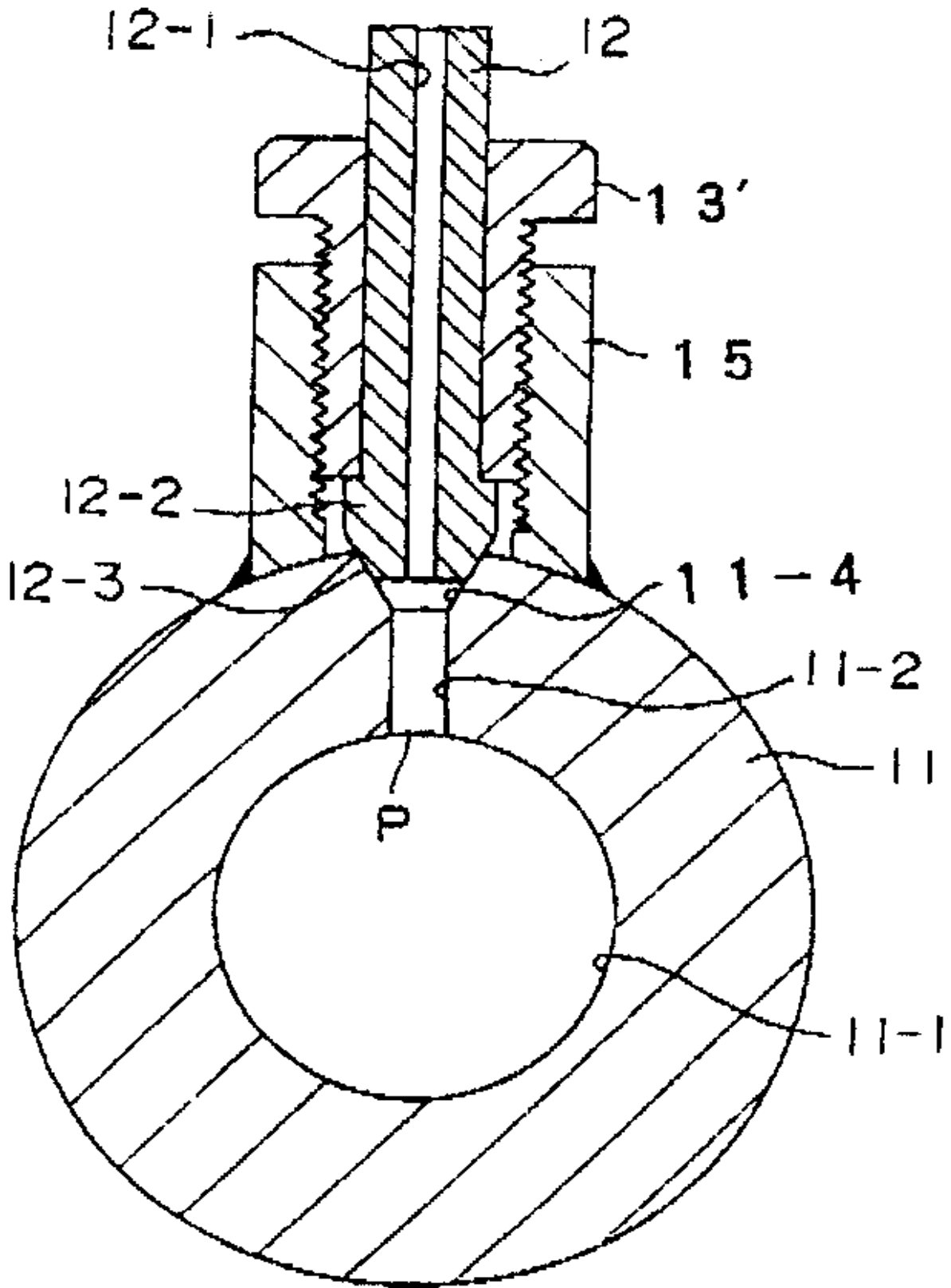

(종래 기술)

