

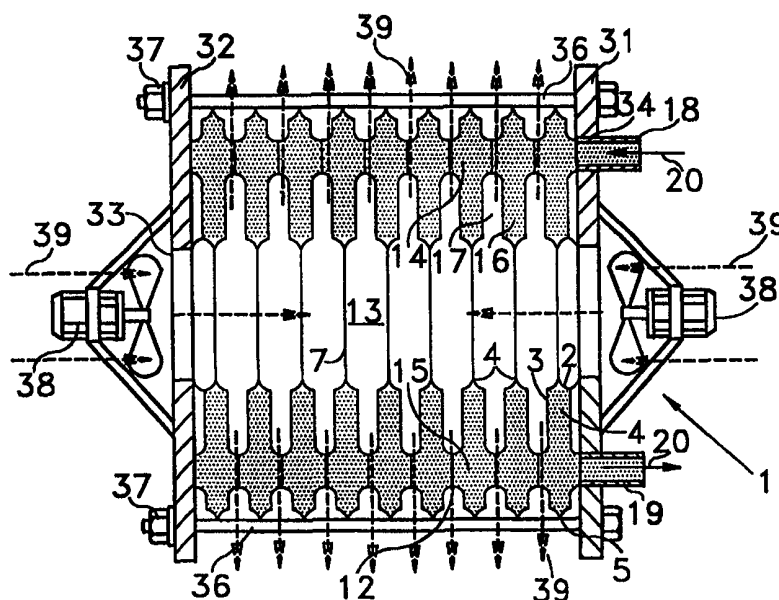

INTERNATIONAL APPLICATION PUBLISHED UNDER THE PATENT COOPERATION TREATY (PCT)

<p>(51) International Patent Classification ⁶ : F28D 9/00, F28F 3/10 // 9/26</p>	<p>A1</p>	<p>(11) International Publication Number: WO 99/30099 (43) International Publication Date: 17 June 1999 (17.06.99)</p>
<p>(21) International Application Number: PCT/FI98/00952 (22) International Filing Date: 7 December 1998 (07.12.98) (30) Priority Data: 974476 10 December 1997 (10.12.97) FI (71) Applicant (for all designated States except US): VAHTERUS OY [FI/FI]; Pruukintie 7, FIN-23600 Kalanti (FI). (72) Inventors; and (75) Inventors/Applicants (for US only): KONTU, Mauri [FI/FI]; Vahteruksenraitti 22, FIN-23600 Kalanti (FI). PIRILÄ, Timo [FI/FI]; Piirontanhua 31, FIN-23600 Kalanti (FI). HEINIÖ, Tapio [FI/FI]; Nokikanakuja 16, FIN-23500 Uusikaupunki (FI). (74) Agent: TURUN PATENTTITOIMISTO OY; P.O. Box 99, FIN-20521 Turku (FI).</p>	<p>(81) Designated States: AL, AM, AT, AU, AZ, BA, BB, BG, BR, BY, CA, CH, CN, CU, CZ, DE, DK, EE, ES, FI, GB, GD, GE, GH, GM, HR, HU, ID, IL, IN, IS, JP, KE, KG, KP, KR, KZ, LC, LK, LR, LS, LT, LU, LV, MD, MG, MK, MN, MW, MX, NO, NZ, PL, PT, RO, RU, SD, SE, SG, SI, SK, SL, TJ, TM, TR, TT, UA, UG, US, UZ, VN, YU, ZW, ARIPO patent (GH, GM, KE, LS, MW, SD, SZ, UG, ZW), Eurasian patent (AM, AZ, BY, KG, KZ, MD, RU, TJ, TM), European patent (AT, BE, CH, CY, DE, DK, ES, FI, FR, GB, GR, IE, IT, LU, MC, NL, PT, SE), OAPI patent (BF, BJ, CF, CG, CI, CM, GA, GN, GW, ML, MR, NE, SN, TD, TG).</p> <p>Published With international search report. In English translation (filed in Finnish).</p>	

(54) Title: PLATE HEAT EXCHANGER



(57) Abstract

The invention relates to a plate heat exchanger (1) which consists of a plate stack (12) composed of advantageously circular grooved plates (2, 3) welded together. The clearances between the plates (2, 3) form flow ducts (16, 17) for flows of a heat-supplying medium and a heat-receiving medium. The plates (2, 3) are provided with holes (6, 8, 9) which form inlet and outlet channels (13, 14, 15) for the flows (20, 39) of the heat transfer media. At least one of the holes (6) on the plates (2, 3) is located substantially in the centre of the plate (2, 3). The plate heat exchanger (1) operates on the cross flow principle. When the plate heat exchanger (1) is provided with a partly opened mantle which connects the end plates (31, 32) together, and the central channel (13) is provided with a partly opened pipe to control the flows, the plate heat exchanger (1) is made to function both on the counter flow principle and the forward flow principle.

FOR THE PURPOSES OF INFORMATION ONLY

Codes used to identify States party to the PCT on the front pages of pamphlets publishing international applications under the PCT.

AL	Albania	ES	Spain	LS	Lesotho	SI	Slovenia
AM	Armenia	FI	Finland	LT	Lithuania	SK	Slovakia
AT	Austria	FR	France	LU	Luxembourg	SN	Senegal
AU	Australia	GA	Gabon	LV	Latvia	SZ	Swaziland
AZ	Azerbaijan	GB	United Kingdom	MC	Monaco	TD	Chad
BA	Bosnia and Herzegovina	GE	Georgia	MD	Republic of Moldova	TG	Togo
BB	Barbados	GH	Ghana	MG	Madagascar	TJ	Tajikistan
BE	Belgium	GN	Guinea	MK	The former Yugoslav Republic of Macedonia	TM	Turkmenistan
BF	Burkina Faso	GR	Greece			TR	Turkey
BG	Bulgaria	HU	Hungary	ML	Mali	TT	Trinidad and Tobago
BJ	Benin	IE	Ireland	MN	Mongolia	UA	Ukraine
BR	Brazil	IL	Israel	MR	Mauritania	UG	Uganda
BY	Belarus	IS	Iceland	MW	Malawi	US	United States of America
CA	Canada	IT	Italy	MX	Mexico	UZ	Uzbekistan
CF	Central African Republic	JP	Japan	NE	Niger	VN	Viet Nam
CG	Congo	KE	Kenya	NL	Netherlands	YU	Yugoslavia
CH	Switzerland	KG	Kyrgyzstan	NO	Norway	ZW	Zimbabwe
CI	Côte d'Ivoire	KP	Democratic People's Republic of Korea	NZ	New Zealand		
CM	Cameroon			PL	Poland		
CN	China	KR	Republic of Korea	PT	Portugal		
CU	Cuba	KZ	Kazakistan	RO	Romania		
CZ	Czech Republic	LC	Saint Lucia	RU	Russian Federation		
DE	Germany	LI	Liechtenstein	SD	Sudan		
DK	Denmark	LK	Sri Lanka	SE	Sweden		
EE	Estonia	LR	Liberia	SG	Singapore		

Plate heat exchanger

The present invention relates to an advantageously welded plate heat exchanger according to the preamble of claim 1, for transferring heat from a heat-supplying
5 medium to a heat-receiving medium, especially between substances in different phase, such as liquid and gas.

Conventionally, heat exchangers are divided into heat exchangers with a plate structure and those with a pipe structure. The significant difference concerning
10 both the construction and the heat transfer is that the heat transfer surfaces are mainly pipes in one structure, and plates in the other. In the pipe heat exchanger, a pipe cluster with header and branching parts is usually placed inside a circular mantle. Thanks to the cylindrical shape and the pipes, the structure is well suited as a pressure vessel, and thus pipe heat exchangers have been used in extremely
15 high pressures. In broad perspective, also a large number of boiler constructions are some kind of pipe heat exchangers. This applies to both fire-tube/corrugated flue boilers and water-tube boilers, the division being based on that on which side of the pipe the pressure prevails.

20 The most significant drawback of the pipe heat exchangers can be considered to lie in the heavy weight when compared to the surface area of the heat transfer surfaces. Due to that, the pipe heat exchangers are usually large in size. Also, when considering the heat transfer and flow characteristics, it is difficult to design and manufacture pipe heat exchangers especially when economical
25 grounds have to be taken into account.

A typical plate heat exchanger is composed of rectangular plates which are pressed against each other by means of end plates, which, in turn, are tightened to the ends of the plate stack by means of tension rods or tension screws. The
30 clearances between the plates are closed and sealed with banded sealings on

their outer circumference, and sealings are also used at the flow channels. Since the bearing capacity of sleek plates is poor, they are strengthened with groovings which are usually arranged crosswise in adjacent plates, wherein they also improve the pressure endurance of the structure when the ridges of the grooves are supported to each other. However, a more important aspect is the significance of the grooves for the heat transfer: the shape of the grooves and their angle with respect to the flows, affect e.g. the heat transfer and pressure losses. In a conventional plate heat exchanger, a heat-supplying medium flows in every other clearance between the plates, and a heat-receiving medium in the remaining clearances. The flow is conducted in between the plates via holes located in the vicinity of the corners of the plates. Each clearance between the plates always contains two holes with closed rims and two other holes functioning as inlet and outlet channels for the clearance between the plates. The plate heat exchangers are usually composed of relatively thin plates, wherein a small and light structure is obtained. Because the plates can be profiled into a desired shape, it is possible to make the heat transfer properties suitable for the target of use in the best possible way. The greatest weakness in conventional plate heat exchangers are the sealings which restrict the pressure and temperature endurance of the heat exchangers. In several cases the sealings have impaired the possibilities of use also when the heat-supplying or heat-receiving medium has been corrosive.

Attempts have been made to improve the plate heat exchanger constructions by leaving out some of the sealings or all of them and replacing them with soldered joints or welded seams. Plate heat exchangers fabricated by soldering usually resemble those equipped with sealings. The most significant external difference is the absence of tension screws between the ends. Due to the structure, it has not been possible to disassemble such heat exchangers.

Attempts have been made to combine the advantages of the pipe heat exchanger and the plate heat exchanger in heat exchangers whose construction partly resembles both of these basic types. One such solution is disclosed in Finnish patent publication FI 79409, in which circular or polygonal plates are stacked on top of each other to form a stack of plates which is supported by means of end plates. The plate stack is encircled by a mantle, the sides of which are provided with inlet and outlet channels for flows of heat-supplying and heat-receiving medium. Differing from the conventional plate heat exchanger, all flows into the clearances between the plates are directed from outside the plates. In the publication, the basic problem of the plate heat exchangers, i.e. their tightness, is disregarded as a secondary aspect, without providing any solution to that particular problem. When the heat exchanger according to the publication is closed by welding, it is possible to attain the same pressure classes as when using a pipe heat exchanger, the heat transfer properties corresponding to the properties of the plate heat exchanger.

Finnish patent publication FI 84659 presents a solution which more distinctly shows features typical of both plate heat exchangers and pipe heat exchangers. The circular plates are joined together in pairs by welding them together by the rims of holes which form an inlet and outlet channel. By welding the plate pairs fabricated in the above manner together by the outer perimeters of the plates, a closed circuit is attained for the flow of one heat transfer medium. Differing from the conventional plate heat exchanger, the structure is welded and there are only two holes in the plates. The flow of another heat transfer medium is directed to every other clearance between the plates by means of a mantle surrounding the plate stack. In order to prevent the flow from running between the plate stack and the mantle, sealings are utilized which are primarily used as controllers for the flow. Naturally, pressure endurance is not required of the flow controllers. Due to the structure of the plate stack, it is difficult to implement the sealing. For example, elastic rubber gaskets are used for sealing,

wherein it is possible to disassemble the heat exchanger e.g. for cleaning purposes. Thus, the problem of sealing is not as significant as it is in the solution according to the publication FI 79409.

5 The purpose of this invention is to produce a plate heat exchanger with no sealing problems and with a pressure endurance corresponding to the properties of pipe exchangers, and in which the heat transfer properties can be selected as in a plate heat exchanger. The sealing problems are avoided by welding the joints, and the controllers can be entirely removed between the mantle and the
10 plate stack. The plate heat exchanger according to the invention has an extremely wide range of use, and it can be utilized for heat transfer between media in different phases.

The invention is based on the idea that there are holes in the centre of the
15 circular heat exchange plates, which holes form a flow channel for one heat transfer medium, by means of which channel the flow is guided into the clearances between the plates and out of them. For the flow of the other heat transfer medium, the plates are provided with separate holes for inlet and outlet channels. Because the plate stack is a solid piece which is welded together, it
20 can be placed in a detachable manner e.g. in a cylinder which can be opened, from which location the plate stack can be removed for cleaning or repair. The central channel can also function as a support means for the end plates, if it is equipped with a rod, pipe, or the like. By means of a partly opened pipe in the central channel and a partly opened mantle, it is possible to alter the flows of the
25 plate heat exchanger according to the invention in an almost unrestricted manner. More precisely, the plate heat exchanger according to the invention is characterized in what will be presented in the claims hereinbelow.

The welded plate heat exchanger according to the invention is advantageously
30 provided with circular grooved plates, which are joined together in such a way

that flow ducts for the heat-supplying medium and heat-receiving medium are formed between the plates. In order to guide the flows into the clearances between the plates and out of them, the plate heat exchanger is equipped with channels which are joined to inlet and outlet fittings. To make the plate stack consisting of relatively thin plates endure pressure, its ends are supported with end plates which are connected together with support means, rods, a mantle, or the like. In the centre of the advantageously circular plates of the plate heat exchanger which form the plate stack and the heat transfer surfaces, there is at least one hole forming a central channel. The plates of the plate heat exchanger are joined together in pairs by the outer perimeters of the holes located in the centre of the plates and by the outer perimeters of the plates of the plate pair in question, in such a way that a closed flow duct for one heat transfer medium is formed inside the plate pairs. In addition to the hole in the centre, the plates of the plate pair are provided with at least one hole by which the plate is attached to a corresponding hole in the adjacent plate pair. Typically, the plates are provided with two holes in addition to the hole in the centre, the holes forming the inlet and outlet channels for the flow ducts inside the plate pairs. The outer perimeters of the flow ducts formed between the plate pairs are open, and the flow into and out of them takes place via the central channel.

20

The plate stack composed of the plates of the plate heat exchanger is supported between the end plates. The end plates can be fixed to each other with rods, or the like, wherein the outer perimeter of the plate heat exchanger is primarily left open, or the end plates can be joined with a mantle structure whereby the entire outer perimeter can be closed. The central channel can also be provided with a pipe or the like, to support the end plates. The flow of the heat transfer medium enters or leaves the open central channel in the radial direction of the plate. Thus, the flow of the second heat transfer medium crosses the flow of the first one, wherein the plate heat exchanger is a cross flow exchanger. The mantle of the plate heat exchanger can be opened at the desired location in order to supply

30

the flow of the heat transfer medium or to discharge it from the plate heat exchanger. The flows are controlled by the mantle located against the plate stack, by a pipe located in the central channel against its walls and by openings on the mantle and in the pipe. By selection of the locations of the openings and
5 holes on the plates, the plate heat exchanger is made to function both as a forward flow exchanger and a counter flow exchanger. The cross-sectional area of the flow between the plates is increased by the parallel flow on both sides of the central channel. The flow conditions between the plates can be controlled by changing the angle β between the ridges of the grooves on the plates placed
10 against each other, wherein by using smaller angles, greater flow quantities are attained for flows of gaseous media through the heat exchanger. Accordingly, the flows of liquid media can be smaller and the angle β can be wider. By making the cross-sectional areas of the grooves in the plates variable in size $A_1 > A_2$, it is possible to convey greater volume flows on the gas side than on
15 the liquid side. The grooves on the plates of the plate heat exchanger can also be made symmetrically with respect to the centre of the plate. Thus, the flow conditions remain almost equal in the different parts of the plate and in all flow types.

20 The plate heat exchanger according to the invention has a simple structure. Due to the circular shape, it is possible to automate the manufacturing techniques, e.g. the welding, with relatively low costs. The circular shape also improves pressure endurance. When using a cylindrical outer shell, one end can be arranged to be opened, wherein it is possible to clean the heat transfer surfaces
25 on at least one side. It is possible to incorporate a large heat transfer surface into the small size and light weight. The plate heat exchanger according to the invention can be made of a corrosion resistant material, for example titanium, with moderate costs because, due to the structure, the material thicknesses of the plates are small.

The welded plate heat exchanger according to the invention can be used in a wide variety of ways and in numerous situations. The plate heat exchanger can be used as a cross flow, forward flow and counter flow heat exchanger. Heat transfer between media in different phases and in the same phase is possible. In different fields of technology, besides being used as a conventional heat exchanger, the heat exchanger according to the invention can also be used i.a. as a cooler, an evaporator, a condenser, a boiler, and a waste heat boiler.

10 In the following, the invention will be described in more detail by means of examples and with reference to the appended drawings, in which

Fig. 1 shows a plate heat exchanger according to the invention in a cross-cut schematical side view, in an embodiment where the plate heat exchanger has an open outer perimeter,

15

Fig. 2 shows schematically the position of the superimposed plates of the plate heat exchanger as well as the position of the grooves of the plates in the plate stack,

20

Fig. 3 shows a part of the plate stack formed by the plates according to Fig. 2,

Fig. 4 shows the profiles of the plates of Figs. 2 and 3 in a cross-section,

25

Fig. 5 shows a part of the plate stack in which the grooves of the plates are levelled at their bottom,

Fig. 6 shows the profiles of the plates according to Fig. 5 in a cross-section,

30

- Fig. 7 shows a schematical side view of the cross-section of a plate heat exchanger according to the invention in an embodiment comprising a mantle and a pipe arranged in the central channel,
- 5
- Fig. 8 shows schematically a cross-cut plate heat exchanger provided with an opened mantle and a central pipe, and functioning on a counter flow principle,
- 10 Fig. 9 shows schematically the plate stack of the plate heat exchanger and the values to be used in calculations, and
- Fig. 10 shows a schematical top view of the plate stack of the plate heat exchanger in an embodiment where the plates are grooved
- 15 symmetrically with respect to their centre.

In Fig. 1, a welded plate heat exchanger 1 is used as a cooler or a heater. In order to simplify the schematical Fig. 1, the grooves on the plates of the plate heat exchanger are not shown in the figure. In Figs. 1 to 10, plates 2 and 3 form

20 a plate pair 4 which is conjoined for example by welding at the outer perimeters 5. Similarly, the plate pair 4 is conjoined at the central hole 6 of the plates 2 and 3, along its perimeter 7. The plate pairs 4 are attached together by welding at holes 8 and 9, along their outer perimeters 10 and 11. The plate pairs 4 joined together form a plate stack 12, inside of which a central channel 13 is formed of

25 the central holes 6 of the plates 2, 3. Correspondingly, the holes 8 and 9 form the inlet and outlet channels 14 and 15 for one heat transfer medium in the inner flow ducts 16 of the plate stack. The central channel 13 is connected to the flow ducts 17 between the plate pairs 4. The inlet and outlet channels 14 and 15 for the inner flow of the plate stack 12 are connected on at least one end to an inlet

fitting 18 and an outlet fitting 19. The flow of the heat transfer medium in this circuit is shown by unbroken arrows 20.

The reference number 21 refers to the grooves on the plates 2 and 3, the bottom of the grooves forming a ridge 22 or a level surface 23. Fig. 2 shows the angle β between the ridges of the superimposed plates 2 and 3. Figs. 3 to 6 illustrate how the cross-sectional areas A_1 and A_2 formed by the grooves 21 vary in size. With the shape and placement of the grooves 21, a desired proportion is achieved for the cross-sectional areas. For example, the flow volumes of a gaseous medium can be increased by increasing the cross-sectional area of the flow duct 16 or 17. The plates 2 and 3 support each other via supporting points 24, at which the ridges 22 and/or level surfaces 23 of the grooves 21 are placed against each other. The structural strength required, the materials of the plates 2 and 3, and the shape of the grooves 21 set the limits to the proportion between the cross-sectional areas A_1 and A_2 .

To support the plate stack 12, rigid end plates 31 and 32 are used. The end plates 31 and/or 32 are provided with the necessary holes 33, 34 and 35 for the channels 13, 14 and 15 or their fittings 18, 19. In the solution according to Fig. 1, the end plates 31 and 32 are tied together by means of bolts 36 and nuts 37. In order to illustrate the function, Fig. 1 shows blowers 38 which are fixed to the end plates 31 and 32 and which generate gas flows illustrated by broken line arrows 39.

Figs. 7 and 8 show an embodiment of the plate heat exchanger, in which the flow ducts 16 and 17 of both the heat-supplying and the heat-receiving medium are closed and they can be pressurized. The end plates 31 and 32 are connected together by means of a mantle 41 surrounding the plate stack 12. For maintenance purposes, one of the end plates 31, 32 is attached to the mantle 41 in such a way that it can be easily detached. A pipe 42 or the like is fixed to an

10

opening 43 in the mantle 41, and through which opening the flow 39 of one heat transfer medium is guided to the plate heat exchanger 1 or out of the same. The central channel 13 of the plate stack 12 is provided with a pipe 44 which has an opening 45 for the flow, either into the pipe 44 or out of the same. Fig. 8 clearly shows that by changing the direction of the flows 20, it is possible to convert a counterflow heat exchanger to a forward flow heat exchanger. By shifting the location of the channels 14 and 15 by 90°, the plate heat exchanger 1 according to Fig. 8 can be made to function on the cross flow principle. In conventional plate heat exchangers which comprise four holes, the above-presented modifications have not always been possible.

The following formulas apply to the calculations used in connection with a plate heat exchanger with circular plates:

$$15 \quad \Delta p \approx d_h^{-1.2} L_{ekv} w^{1.8} \quad (\text{pa}) \text{ pressure loss}$$

$$a \approx d_h^{-0.36} w^{0.64} \quad (\text{W/m}^2\text{K}) \text{ heat-transfer coefficient}$$

d_h = hydraulic diameter in the groove (m)

20

w = flow rate between the plates (m/s)

L_{ekv} = equivalent flow length between the plates

25 $L_{ekv} = f(\alpha, L)$ Fig 9 shows that α = the angle of ascent of the groove with respect to the flow direction and L = flow length

$$L_{ekv} \approx (\sin \alpha)^{-1} (\cos \alpha)^{0.7} L$$

When examining the effect of the angle α to the equivalent flow length, it can be found that when the angle changes for example in the order of 45° to 15° , the equivalent flow length increases into treble and above that. In test runs, the plate heat exchangers according to the invention have attained heat transfer coefficient values which exceed $300 \text{ W/m}^2\text{K}$. The heat transfer properties of the plate heat exchanger 1 can also be affected not only by the shape of the grooves 21 on plates 2, 3 and the angle β between the ridges 22 of the grooves, but also by the size of the central hole 6. Correspondingly, by shortening the flow length for example in cases of radial flow, it is possible to increase the value of the angle β and to keep the pressure loss constant, and thus to find the optimal values for each use. The possibilities for variation are almost unlimited.

In the solution according to Fig. 10, the grooves 21 and their ridges are in a symmetrical position with respect to the centre. Thus, the value of the angle α is the same everywhere, both in circular flows and in radial flows.

As disclosed in the foregoing, there are numerous possibilities of using the plate heat exchanger 1 according to the invention. Structurally, the plate heat exchanger 1 can be either open or closed, wherein in the former case it has a primarily open outer perimeter, and in the latter case it is primarily closed with a mantle or the like. When using the open plate heat exchanger 1 for example as a cooler or a heater, the most advantageous result is achieved by conducting the gas flow 39 to the central channel 13 or out of the same in a forced flow by means of blowers 38 or the like. In the central channel 13, the flow can also be unidirectional, wherein only one end plate 31, 32 is provided with a hole 33. When the central channel 13 is in vertical position, a free flow of the gas can also be possible. The flow 20 inside the plate stack 12 can be forced or free. The plate heat exchanger according to Fig. 1 functions as a cooler in free circulation. The warm medium flow 20 supplied from above is discharged from

below by the effect of gravity. Also, on the basis of phase transitions, a sufficient circulation is attained for example in condensers and evaporators.

However, in the closed plate heat exchanger 1 the best capacity is typically achieved when both flows are forced. When functioning both according to the forward flow principle and according to the counterflow principle, the flows of the heat transfer media are passed in the direction of the perimeters of the plates 2 and 3 both in the inner and in the outer flow ducts 16, 17 of the plate stack 12. The inner surface of the mantle 41 abuts the outer perimeters of the plates 2 and 3, which perimeters are welded together, and the outer surface of the pipe 44, located in the central channel 13, abuts the welded perimeters 7 of the holes 6. In the aforementioned locations in the outer flow ducts 17 of the plate stack 12, broader flow ducts are composed, because the grooves 21 are absent therein. The distance from the opening 43 along the inner surface of the mantle 41 to the opening 45 of the pipe 44 located in the central channel 13 is, however, considerably longer than the distance via the centre of the plates 2, 3. The flows on the inner surface of the mantle 41 and on the outer surface of the pipe 44 are minor so that it is not necessary to take them into account, and thus separate flow controllers or sealings are not necessary. The free flow based on gravity may become optional in a closed plate heat exchanger 1 when the construction is used for example as a boiler, wherein the central channel 13 functions as a combustion chamber and the plate stack 12 forms a convection part. The heated water rises from the channel 15 via the flow ducts 16 to the channel 14. Correspondingly, the closed plate heat exchanger 1 according to the invention can also be utilized as a waste heat boiler for various purposes of use. The circulation of the liquid can thus be arranged either in free or in forced circulation. Due to its pressure endurance and compact size, the closed plate heat exchanger according to the invention can be especially well used e.g. as an evaporator or a condenser in apparatuses applying the refrigeration technique.

Figs. 1 to 10 do not show the structure of the plate heat exchanger 1 according to the invention in which the plate stack is placed inside a spacious mantle 41 and there is no pipe 44 controlling the flow inside the central channel 13. Such a structure is closed and it is well suited e.g. for corrosive conditions in sea water heat exchangers. The parts of the mantle 41 and the end plates 31 and 32 receiving the loads caused by the pressure can be made of constructional steel, and the inner surfaces which are liable to corrosion are coated with corrosion resistant materials. The plate stack 12 containing the welded heat transfer surfaces can be made of titanium which is highly resistant to corrosion. Such a structure can also be used in processing industry and chemical industry, in different types of reactors or the like.

In plate heat exchangers 1, where the inner diameter of the mantle 41 is greater than the outer diameter of the plate stack 12, a ring-shaped channel is formed between the mantle 41 and the plate stack 12, to which channel a flow is directed from the central channel 13 along the flow ducts 17, or from which a flow is directed to the central channel 13.

It is obvious for anyone skilled in the art, that only few of the constructions and uses of the plate heat exchanger 1 according to the invention are disclosed in the foregoing. By combining the above-presented embodiments, it is possible to obtain entirely new solutions within the scope of the inventive idea. By the shape and distribution of the grooves 21, it is possible to affect the pressure losses and to construct the plate heat exchanger 1 in such a way that it also functions e.g. with consistent viscous media. Naturally, the plates 2 and 3 of the plate heat exchanger 1 can also be different, or some of the plates in the plate stack 12 can be different. It is possible to divide the channels 13, 14, 15 of the plate heat exchanger 1 for the purpose of grading the heat transfer. The plates 2 and 3 of the plate stack 12 can, of course, be joined together with other methods

and in a different order as opposed to what has been presented above within the scope of the inventive idea. Besides welding, the joining can be conducted by means of adhesives, by soldering, or with corresponding techniques.

Claims:

1. Welded plate heat exchanger (1) intended for heat transfer between flows of media in the same phase or in different phases, such as liquid and gas, and
- 5 comprising
- advantageously circular plates (2, 3) joined together and forming the heat transfer surfaces of the plate heat exchanger (1), wherein two plates (2, 3) joined together form one plate pair (4) and adjacent plate pairs (4) joined together form a plate stack (12),
 - 10 - flow ducts (16, 17) for a heat-supplying medium and a heat-receiving medium formed between the plates (2, 3) joined together,
 - channels (13, 14, 15) directing the heat-supplying and heat-receiving flows to the flow ducts (16, 17) and out of the same and the inlet and outlet fittings (18, 19) of the channels, and
 - 15 - end plates (31, 32) supporting the plate stack (12) and support means (36, 37, 41) therebetween, **characterized** in that
 - the advantageously circular plates (2, 3) of the plate heat exchanger (1) which form the heat transfer surfaces and the central channel (13), are provided with at least one hole (6) substantially in the centre of the plate
 - 20 (2, 3),
 - the plates (2, 3) of the plate heat exchanger (1) are joined together as plate pairs (4) by welding at the perimeters (7) of the holes (6) in the centre of the plates (2, 3) and at the outer perimeters (5) of the plates (2, 3) in the same plate pair (4), and that
 - 25 - the plate pairs (4) closed at the perimeters (7) of the holes (6) and by the outer perimeters (5), are welded together at least in one location along the perimeters (10, 11) of holes (8, 9) located outside the centre of the plates (2, 3) in the plate pair (4).

2. Plate heat exchanger according to claim 1, **characterized** in that the flow ducts (17) formed between the plate pairs (4) of the plate heat exchanger (1) are open in their outer perimeter, and the central channel (13) formed by the holes (6) in the centre of the plates (2, 3) is the inlet or outlet channel for the flow ducts (17).

3. Plate heat exchanger according to claims 1 to 2, **characterized** in that the plate stack (12), formed by the plates (2, 3) of the plate heat exchanger (1), is arranged between end plates (31, 32) which are supported to each other and clamped together, so that the plate heat exchanger (1) has a substantially open outer perimeter.

4. Plate heat exchanger according to claim 1, **characterized** in that the support means supporting the plate stack (12) between the end plates (31, 32) is a mantle (41), wherein the end plates (31, 32) and the mantle (41) form a space in which the plate stack (12) is arranged.

5. Plate heat exchanger according to claims 1 to 4, **characterized** in that the flow of the heat transfer medium entering or leaving the central channel (13) of the plate heat exchanger (1) is substantially parallel to the radii of the plates (2, 3), and the flow of the other heat transfer medium is substantially perpendicular to the radii of the plates (2, 3), wherein the plate heat exchanger (1) functions on a cross flow principle.

6. Plate heat exchanger (1) according to claim 4, **characterized** in that the mantle (41) is partly open to supply the flow of the heat transfer medium to the plate heat exchanger (1) or to discharge it from the same.

7. Plate heat exchanger according to claims 1 to 6, **characterized** in that the central channel (13) of the plate heat exchanger (1) is provided with a pipe (44)

or the like which is partly open and which controls the flow of the heat transfer medium entering or leaving the central channel (13).

8. Plate heat exchanger according to claims 1 to 7, **characterized** in that the end
5 plates (31, 32) of the plate heat exchanger (1) are fixed and supported both to the mantle (41) and to the pipe (44), or the like, arranged in the central channel (13).

9. Plate heat exchanger according to claims 1, 4, 6, 7, and 8, **characterized** in
10 that openings (43, 45) located in the mantle (41) of the plate heat exchanger (1) and in the pipe (44) placed in the central channel (13) as well as the holes (8, 9) connecting the plate pairs (4) together, are arranged with respect to each other in such a way that the flows of heat transfer media run in opposite directions, wherein the plate heat exchanger functions on a cross flow principle.

15

10. Plate heat exchanger according to claims 1, 4, 6, 7 and 8, **characterized** in that openings (43, 45) located in the mantle (41) of the plate heat exchanger (1) and in the pipe (44) placed in the central channel (13) as well as the holes (8, 9) connecting the plate pairs (4) together, are arranged with respect to each other in
20 such a way that the flows of heat transfer media run in the same direction, wherein the plate heat exchanger functions on a forward flow principle.

11. Plate heat exchanger according to claims 1 to 10, **characterized** in that the grooves (21) on each plate (2, 3) of the plate heat exchanger (1) are parallel to
25 each other, and that the angle β between the ridges (22) of the grooves (21) on the plates (2, 3) placed against each other is substantially smaller in the flow ducts (16, 17) containing a gaseous heat transfer medium than in the flow ducts (16, 17) containing a liquid heat transfer medium.

12. Plate heat exchanger according to claims 1 to 10, **characterized** in that the plates (2, 3) of the plate heat exchanger (1) are grooved in such a way that in the flow ducts (16, 17) containing a gaseous heat transfer medium, the cross-sectional area (A_1) of the grooves (21) is larger than the cross-sectional area
5 (A_2) of the grooves (21) in the flow ducts containing liquid heat transfer media.

13. Plate heat exchanger according to claims 1 to 10, **characterized** in that the grooves (21) on the plates (2, 3) of the plate heat exchanger (1) are arranged symmetrically with respect to the centres of the plates (2, 3).

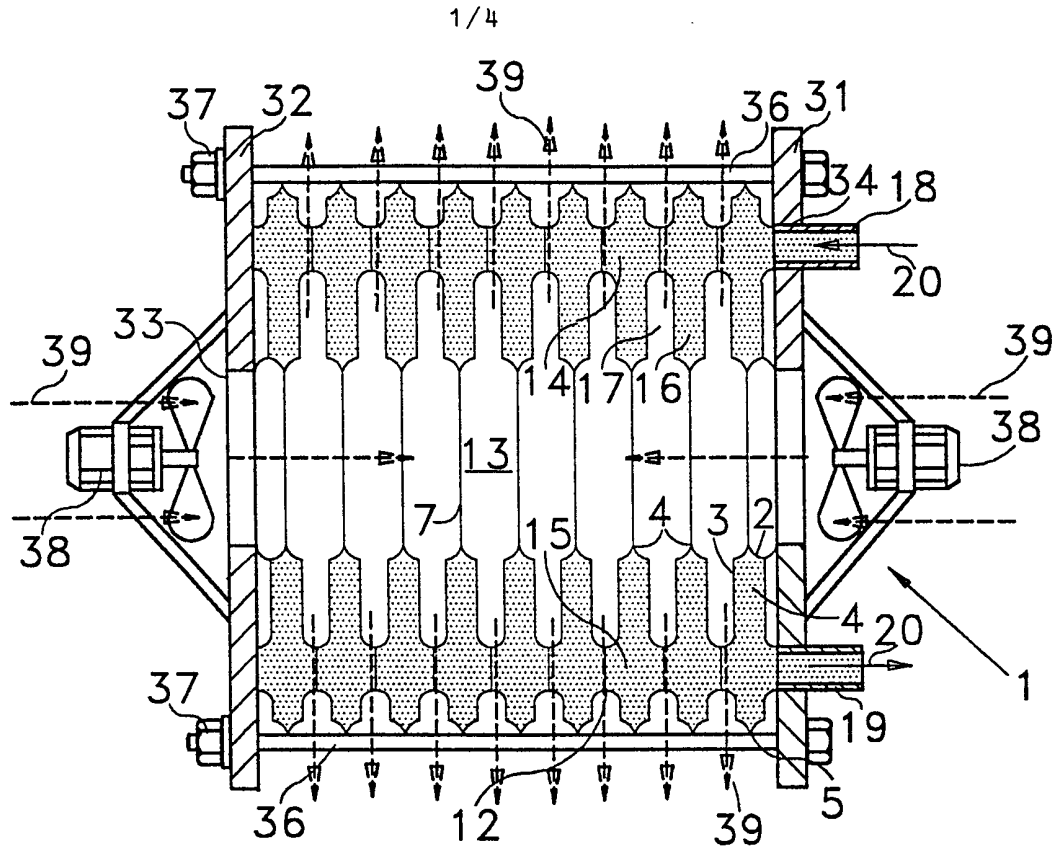

FIG 1 ×

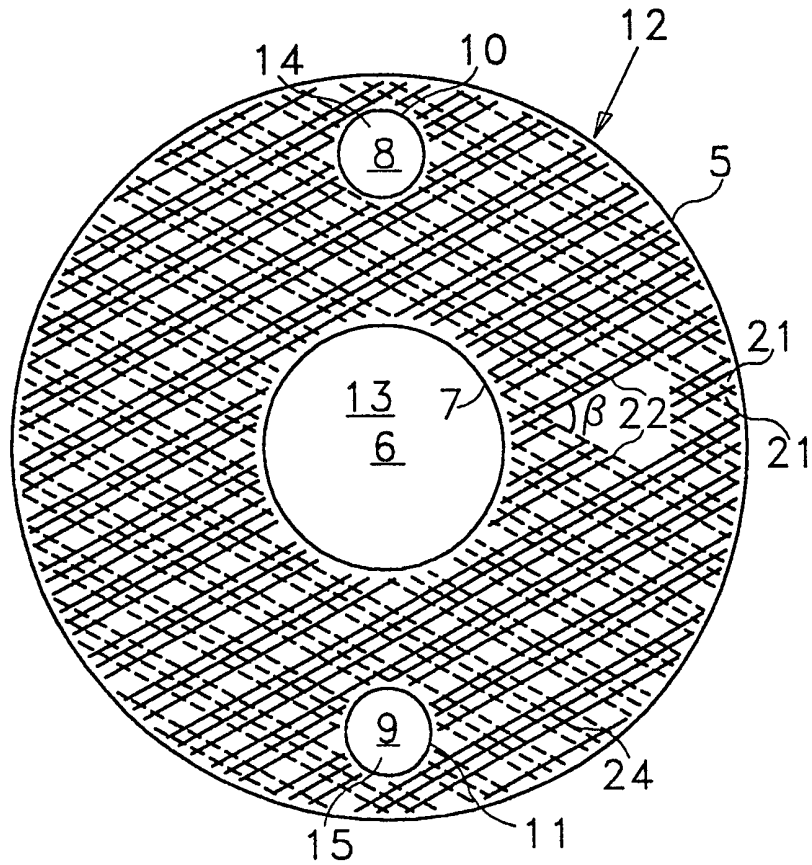

FIG 2

2/4

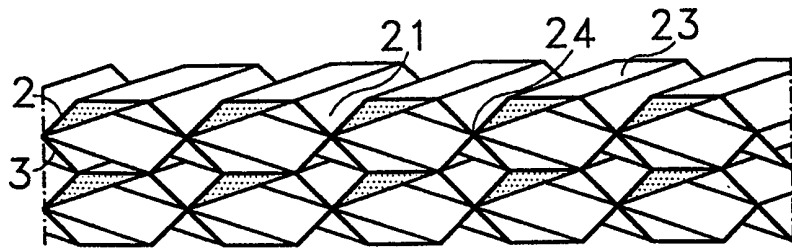

FIG 3

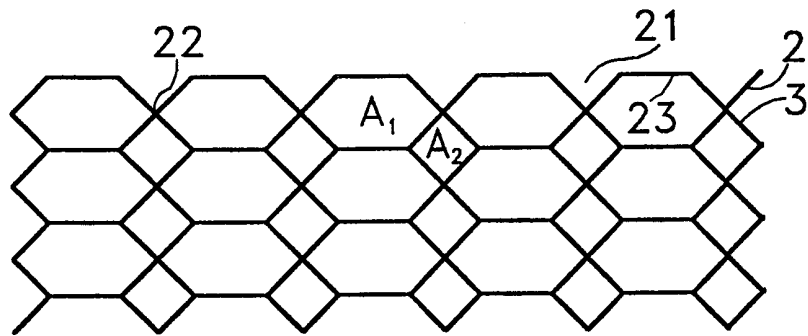

FIG 4

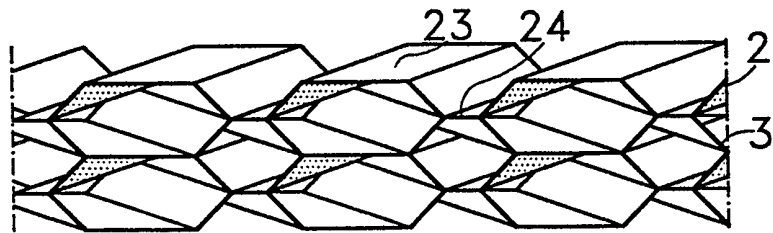

FIG 5

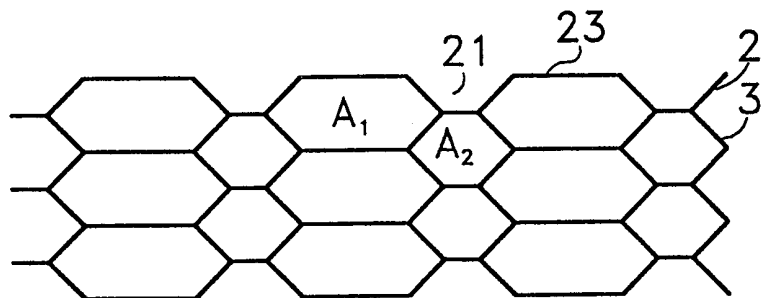

FIG 6

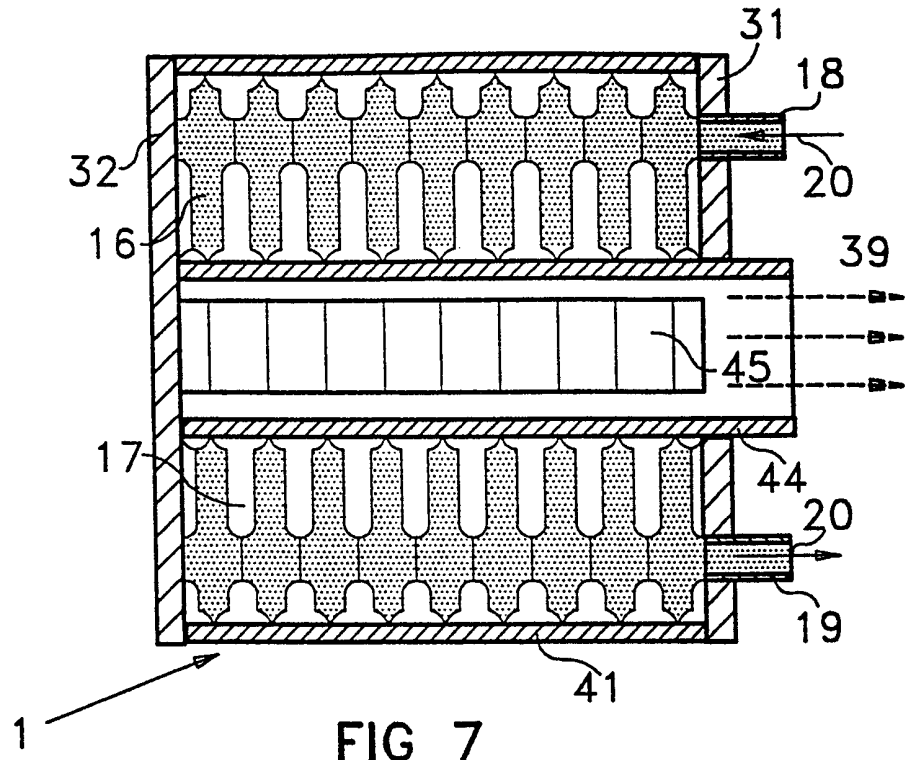

FIG 7

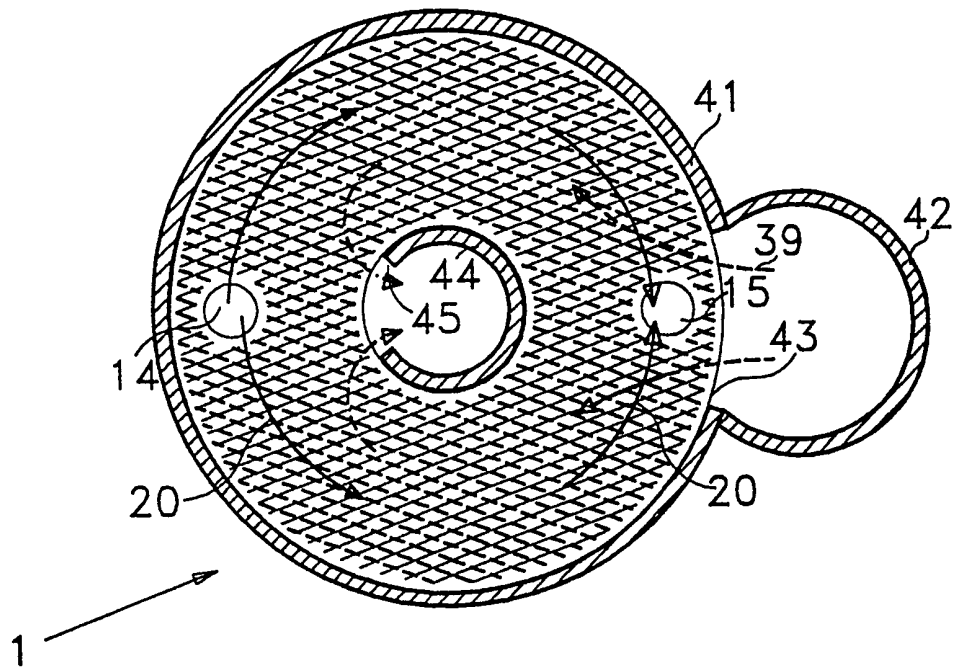

FIG 8

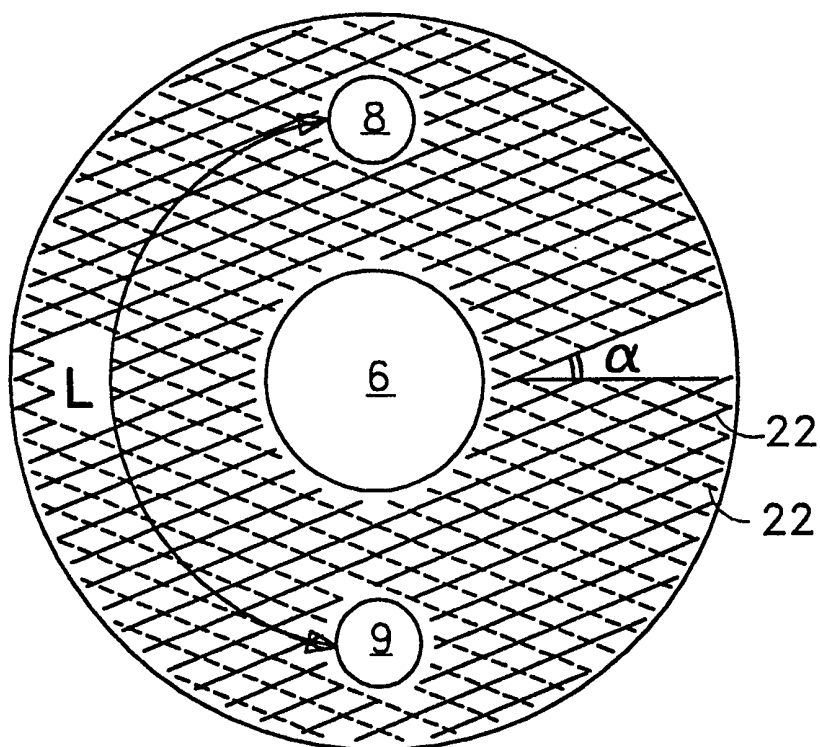

FIG 9

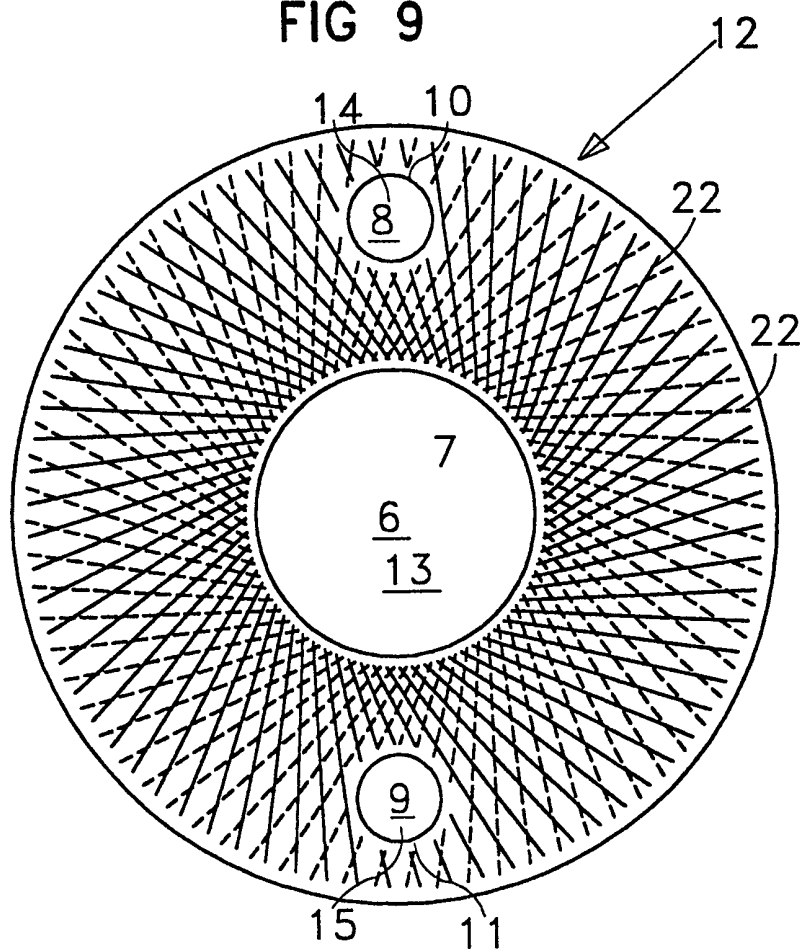

FIG 10

INTERNATIONAL SEARCH REPORT

International application No.

PCT/FI 98/00952

A. CLASSIFICATION OF SUBJECT MATTER		
IPC6: F28D 9/00, F28F 3/10 // F28F 9/26 According to International Patent Classification (IPC) or to both national classification and IPC		
B. FIELDS SEARCHED		
Minimum documentation searched (classification system followed by classification symbols)		
IPC6: F28D, F28F		
Documentation searched other than minimum documentation to the extent that such documents are included in the fields searched		
SE,DK,FI,NO classes as above		
Electronic data base consulted during the international search (name of data base and, where practicable, search terms used)		
C. DOCUMENTS CONSIDERED TO BE RELEVANT		
Category*	Citation of document, with indication, where appropriate, of the relevant passages	Relevant to claim No.
X	DE 3008717 A1 (WITZEMANN GMBH METALLSCHLAUCH-FABRIK PFORZHEIM), 17 Sept 1981 (17.09.81), figures 1,4 --	1,2,3,5
X	US 3831674 A (STEIN ET AL), 27 August 1974 (27.08.74), column 4, line 8 - line 41 --	1-3
X	US 3385353 A (S. STRANITI ET AL), 28 May 1968 (28.05.68), column 2, second paragraph; detail (56) --	1-3,5
X	US 3785435 A (STEIN ET AL), 15 January 1974 (15.01.74), details (27), (28) --	1-3,5
<input checked="" type="checkbox"/> Further documents are listed in the continuation of Box C. <input checked="" type="checkbox"/> See patent family annex.		
* Special categories of cited documents: "A" document defining the general state of the art which is not considered to be of particular relevance "E" earlier document but published on or after the international filing date "L" document which may throw doubts on priority claim(s) or which is cited to establish the publication date of another citation or other special reason (as specified) "O" document referring to an oral disclosure, use, exhibition or other means "P" document published prior to the international filing date but later than the priority date claimed		"T" later document published after the international filing date or priority date and not in conflict with the application but cited to understand the principle or theory underlying the invention "X" document of particular relevance: the claimed invention cannot be considered novel or cannot be considered to involve an inventive step when the document is taken alone "Y" document of particular relevance: the claimed invention cannot be considered to involve an inventive step when the document is combined with one or more other such documents, such combination being obvious to a person skilled in the art "&" document member of the same patent family
Date of the actual completion of the international search		Date of mailing of the international search report
26 March 1999		30-03-1999
Name and mailing address of the ISA/ Swedish Patent Office Box 5055, S-102 42 STOCKHOLM Facsimile No. +46 8 666 02 86		Authorized officer Annette Riedel Telephone No. +46 8 782 25 00

INTERNATIONAL SEARCH REPORT

International application No.

PCT/FI 98/00952

C (Continuation). DOCUMENTS CONSIDERED TO BE RELEVANT		
Category*	Citation of document, with indication, where appropriate, of the relevant passages	Relevant to claim No.
X	US 4431050 A (MARTIN), 14 February 1984 (14.02.84), column 5, first paragraph --	1,2
X	US 4917181 A (KIERNAN, JR. ET AL), 17 April 1990 (17.04.90), column 2, first paragraph, column 4, line 47 --	1,2,4-6
X	US 3424240 A (W.J. STEIN ET AL), 28 January 1969 (28.01.69), figures 2-3, column 4, second paragraph Y	1-4,6,7,9,13 10-12
X	DE 19510847 A1 (REHBERG, MICHAEL), 19 Sept 1996 (19.09.96), see the whole document Y	1-4,6,9,13 8,10-12
X	US 4470454 A (LAUGHLIN ET AL), 11 Sept 1984 (11.09.84), figures 3-5 Y	1,2 12
Y	US 5078209 A (KERKMAN ET AL), 7 January 1992 (07.01.92), figure 5 --	10,11
Y	US 4580625 A (YAMANAKA ET AL), 8 April 1986 (08.04.86), figures 1,11, details (19), (31), (37), (21) A	8,10 1,4,6,7,9
	--	

INTERNATIONAL SEARCH REPORT

International application No.

PCT/FI 98/00952

C (Continuation). DOCUMENTS CONSIDERED TO BE RELEVANT		
Category*	Citation of document, with indication, where appropriate, of the relevant passages	Relevant to claim No.
Y	SE 503142 C2 (LONG MANUFACTURING LTD), 1 April 1996 (01.04.96), figures 1,4	12
A	--	4,6,9,12,13
A	US 5343936 A (BEATENBOUGH ET AL), 6 Sept 1994 (06.09.94), figure 3	1,2,4,6,8,9, 13
A	DE 810214 C (SOCIETE DE RECHERCHES TECHNIQUES ET D'EXPLOITATIONS INDUSTRIELLES), 6 August 1951 (06.08.51), figures 1-3, claims 2,5, details (14), (32)	1-3,5,7,13
A	US 984944 A (SOCIETE D'ETUDES ET D'APPLICATIONS INDUSTRIELLES ET COMMERCIALES INTERTECHNIQUE), 12 July 1951 (12.07.51), details (7), (a 61 -a 63)	1-3,5,7,13
A	DE 3938253 A1 (BEHR GMBH & CO.), 23 May 1991 (23.05.91), detail (31)	4,6-10
A	WO 9517272 A1 (KONTU, MAURI), 29 June 1995 (29.06.95)	

INTERNATIONAL SEARCH REPORT
Information on patent family members

International application No.
PCT/FI 98/00952

Patent document cited in search report	Publication date	Patent family member(s)	Publication date
US 5078209 A	07/01/92	AT 125034 T	15/07/95
		AU 632027 B	10/12/92
		AU 7841991 A	20/08/92
		CA 2044819 A	07/08/92
		DE 69111218 D,T	29/02/96
		EP 0498108 A,B	12/08/92
		SE 0498108 T3	
		ES 2077179 T	16/11/95
		JP 4260790 A	16/09/92
		MX 9100738 A	01/01/93
US 4580625 A	08/04/86	GB 2140908 A,B	05/12/84
		JP 1660137 C	21/04/92
		JP 3021835 B	25/03/91
		JP 59191888 A	31/10/84
SE 503142 C2	01/04/96	AU 663126 B	28/09/95
		AU 2880892 A	19/07/93
		DE 69207010 D,T	25/07/96
		EP 0616678 A,B	28/09/94
		GB 2278189 A,B	23/11/94
		GB 9412005 D	00/00/00
		JP 2780872 B	30/07/98
		JP 7500410 T	12/01/95
		SE 9402099 A	15/06/94
		CA 2125889 C	10/12/96
		US 5179999 A	19/01/93
		WO 9312397 A	24/06/93
		US 5343936 A	06/09/94
DE 69004220 D,T	10/03/94		
EP 0430752 A,B	05/06/91		
SE 0430752 T3			
JP 3213996 A	19/09/91		
JP 6048150 B	22/06/94		
US 5179999 A	19/01/93		
US 5203832 A	20/04/93		
DE 810214 C	06/08/51	NONE	
US 984944 A	12/07/51	NONE	
DE 3938253 A1	23/05/91	EP 0428919 A,B	29/05/91
		US 5154225 A	13/10/92
WO 9517272 A1	29/06/95	AU 1244795 A	10/07/95
		EP 0735930 A	09/10/96
		FI 94395 B	31/05/95
		FI 935745 D	00/00/00
		JP 9506826 T	08/07/97
		US 5823253 A	20/10/98

INTERNATIONAL SEARCH REPORT

Information on patent family members

International application No.

PCT/FI 98/00952

Patent document cited in search report	Publication date	Patent family member(s)	Publication date
DE 3008717 A1	17/09/81	NONE	
US 3831674 A	27/08/74	DE 2342173 A,B,C FR 2207266 A,B GB 1419840 A JP 911601 C JP 911625 C JP 49081946 A JP 52040469 B JP 52041500 B JP 52074948 A SE 420345 B,C SE 7613672 A	06/06/74 14/06/74 31/12/75 21/06/78 21/06/78 07/08/74 12/10/77 19/10/77 23/06/77 28/09/81 06/12/76
US 3385353 A	28/05/68	NONE	
US 3785435 A	15/01/74	DE 2342174 A,C FR 2206488 A,B GB 1419839 A JP 885679 C JP 49081948 A JP 52015817 B SE 414828 B,C	30/05/74 07/06/74 31/12/75 12/10/77 07/08/74 04/05/77 18/08/80
US 4431050 A	14/02/84	BR 8206098 A CA 1164449 A EP 0077656 A,B SE 0077656 T3 JP 58136994 A	20/09/83 27/03/84 27/04/83 15/08/83
US 4917181 A	17/04/90	NONE	
US 3424240 A	28/01/69	NONE	
DE 19510847 A1	19/09/96	CA 2215192 A EP 0839308 A WO 9629558 A	26/09/96 06/05/98 26/09/96
US 4470454 A	11/09/84	NONE	