

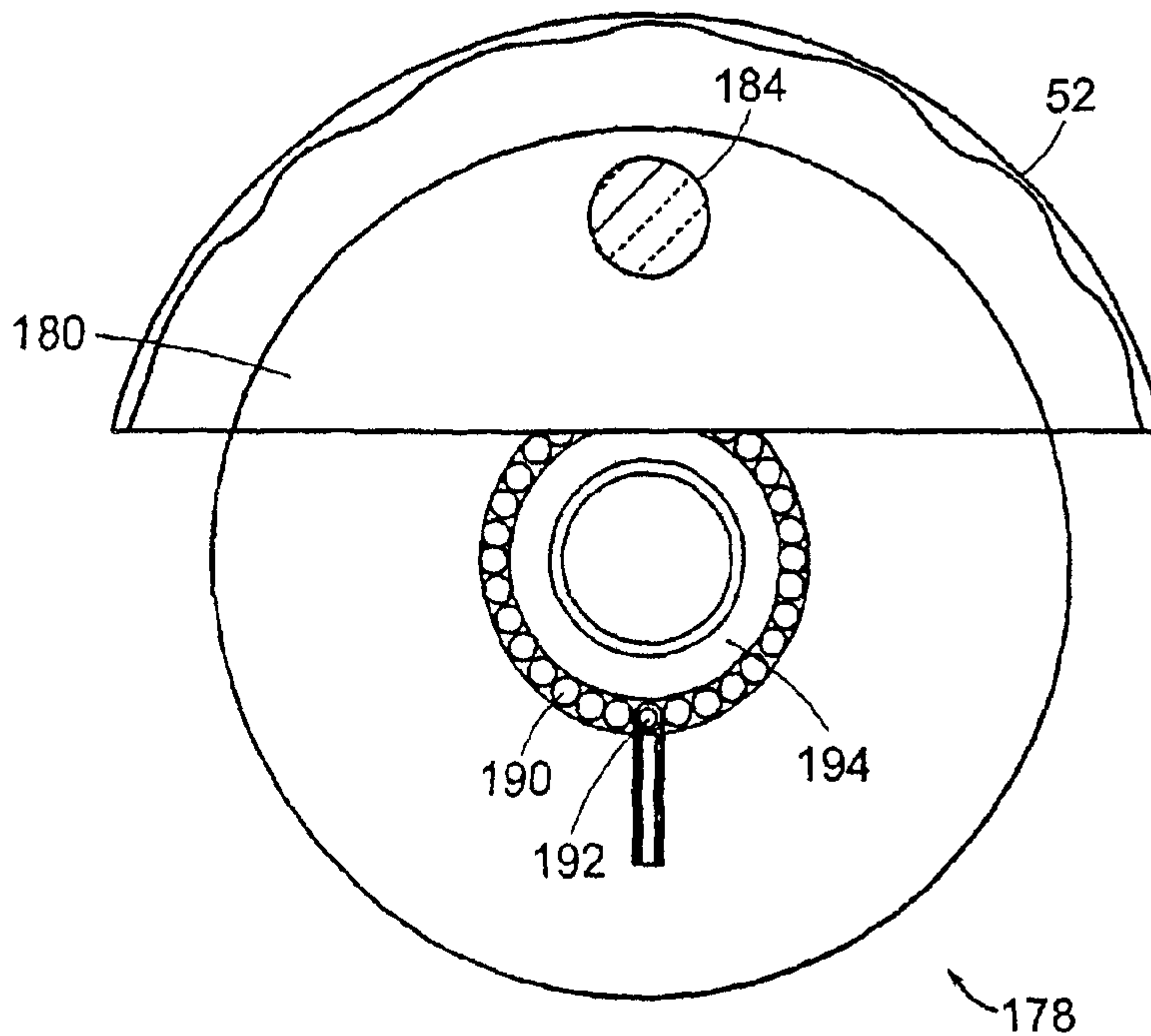

(22) Date de dépôt/Filing Date: 2002/10/18
 (41) Mise à la disp. pub./Open to Public Insp.: 2003/05/01
 (45) Date de délivrance/Issue Date: 2014/02/25
 (62) Demande originale/Original Application: 2 464 091
 (30) Priorité/Priority: 2001/10/19 (US10/042,126)

(51) Cl.Int./Int.Cl. *G02B 23/26* (2006.01),
A61B 1/04 (2006.01), *F21V 8/00* (2006.01),
G02B 6/04 (2006.01)
 (72) Inventeurs/Inventors:
 REMIJAN, PAUL, US;
 MCDONALD, JAMES E., US
 (73) Propriétaire/Owner:
 VISIONSCOPE TECHNOLOGIES LLC, US
 (74) Agent: BORDEN LADNER GERVAIS LLP

(54) Titre : ENDOSCOPE MINIATURE AVEC SYSTEME D'IMAGERIE PAR FIBRE OPTIQUE
 (54) Title: MINIATURE ENDOSCOPE WITH IMAGING FIBER SYSTEM



(57) **Abrégé/Abstract:**

A disposable fiber optic sheath for illuminating a region within a body. The disposable fiber optic sheath including a tubular sheath having an inner tube and an outer tubular surface with a diameter of less than 3 mm and a concentric array of illumination optical fibers within the sheath; and a connector assembly at a proximal end of the sheath.



ABSTRACT

A disposable fiber optic sheath for illuminating a region within a body. The disposable fiber optic sheath including a tubular sheath having an inner tube and an outer tubular surface with a diameter of less than 3 mm and a concentric array of illumination optical fibers within the sheath; and a connector assembly at a proximal end of the sheath.

MINIATURE ENDOSCOPE WITH IMAGING FIBER SYSTEM

This application is a divisional application of co-pending application 2,464,091,
filed October 18, 2002

5 BACKGROUND OF THE INVENTION

Endoscopes enable visual examination of structure inside cavities. In the field of medicine, the use of endoscopes permits inspection of organs for the purposes of diagnosis, viewing of a surgical site, sampling tissue, or facilitating the safe manipulation of other surgical instruments.

10 Laparoscopes, for example, are used particularly for examining organs in the abdominal area. Laparoscopes typically include a light pipe for illuminating the region to be viewed, at least one lens assembly for focusing and relaying the image of the illuminated object, and a housing for the entire assembly which is structured to minimize tissue damage during the surgical procedure. The light pipe can include a
15 fiber optic element for illuminating the site. The laparoscope housing includes a distal section that can be inserted within a body cavity and a proximal section which can include a handle that a user grips to position the distal end near the surgical site.

Existing endoscopes can include an imaging device such as a charged coupled device (CCD). This device can capture an image of an object being viewed and
20 convey it to a display device, such as a monitor. There is a continuing need to improve on the operational features and manufacturability of endoscope systems that improve imaging capability and reduce the risk to the patient.

SUMMARY OF THE INVENTION

The present invention relates to a small diameter imaging probe or endoscope
25 having improved durability, resolution, and field of view. In a preferred embodiment of the invention, the distal end of the probe including a disposable sheath, can be inserted into the tissue under examination. The probe is less than 3 millimeters in diameter, and preferably less than 2 millimeters in diameter, to reduce trauma at the point of insertion and thereby provide access to sites that are otherwise unavailable
30 for endoscopic procedures.

In a preferred embodiment, the endoscope has a fiber optic waveguide that transmits an image from a distal end to a proximal end. A lens system is positioned at the distal end of the fiber optic waveguide. An imaging device is optically coupled to the proximal end of fiber optic waveguide. A sheath extends about the fiber optic waveguide, the sheath including illumination fibers. Although a preferred
5 embodiment utilizes a probe and sheath assembly having an outer diameter of 2 mm or less, certain applications will accommodate a larger diameter instrument having a larger number of imaging fibers to provide a higher resolution image. These applications can utilize outer diameters in a range of 2 – 4 mm.

10 In one embodiment, the lens system having a first lens element, a second lens element and an aperture stop. The lens system couples light from any given position on the object to a plurality of optical fibers such that the numerical aperture of light varies as a function of the angle relative to the longitudinal axis of the lens system. This provides more efficient coupling to the fiber apertures. This is accomplished
15 using a non-telecentric lens system.

A preferred embodiment of the lens system includes a pair of lenses and an aperture stop. The lenses are shaped to improve light collection around the periphery of the distal lens. This provides a clearer image across the entire field of view of the device. The aperture stop is positioned to provide efficient coupling to the array of
20 fibers.

The imaging device can be a charged coupled device (CCD), a CMOS imaging device or other solid state imaging sensor having a two dimensional array of pixel elements. The imaging sensor is mounted on a circuit board in a handle assembly. The sensor can capture an image as an object being viewed and an image
25 processing circuit mounted onto the circuit board transfers the image data over a video cable to a computer for storage, processing and/or display.

The miniature endoscope system can be used for orthopedic, rheumatologic, general laparoscopic, gynecological or ear, nose and throat procedures, for example. Although many applications require a small diameter to reduce trauma, certain
30 applications can accommodate larger diameters. The probe can include an open channel in either the sheath or the imaging probe to provide for the insertion of other

-3-

operative elements to flush the site with fluid, direct light or other energy source onto a treatment site, or to remove a tissue sample.

The sheath assembly can include a concentric array of illumination fibers extending to a connector on a sheath hub assembly. Alternatively, the illumination
5 fibers can couple to a fiber connector in the probe assembly that is coupled directly via fiber optic cable extending from the handle to a light source housing. The housing can include a video disk recorder that writes the video onto disk. For certain applications, an illumination bundle can be positioned within the probe such that the sheath is thinner or can accommodate a larger working channel.

10 BRIEF DESCRIPTION OF THE DRAWINGS

The foregoing and other objects, features and advantages of the invention will be apparent from the following more particular description of preferred embodiments of the invention, as illustrated in the accompanying drawings in which like reference
15 characters refer to the same parts throughout the different views. The drawings are not necessarily to scale, emphasis instead being placed upon illustrating the principles of the invention.

FIG. 1 illustrates a schematic illustration of a miniature endoscope system according to the invention;

FIG. 2 is a cross-sectional view of cannula;

20 FIG. 3 is a cross-sectional view of a trocar within a cannula;

FIG. 4 is a perspective view of the miniature endoscope;

FIG. 5 is a sectional view of the miniature endoscope with a cannula overlying the disposable sheath;

FIG. 6A is a sectional view of the disposable sheath/illuminator unit;

25 FIG. 6B is an enlarged sectional view of the distal end to the disposable sheath;

FIG. 7A is a sectional view of the proximal end of the disposable sheath/illumination unit taken along line 7A – 7A of FIG. 6A;

30 FIG. 7B is a front view of the distal end of the disposable sheath taken along the line 7B – 7B of FIG. 6A and FIG. 6B;

FIG. 8 is a side view of the disposable sheath/illumination unit showing the illumination pigtail;

FIG. 9 is a sectional view of an imaging unit of the miniature endoscope;

FIG. 10A is an enlarged view of the distal end of the imaging unit as indicated
5 by the portion defined 10A in FIG. 9;

FIG. 10B is a front view of the distal end of the imaging unit taken along the line 10B-10B of FIG. 10A;

FIG. 11 is a schematic of an enlarged partial sectional view of the imaging unit taken along the line 11-11 of FIG. 10A;

10 FIG. 12 is an enlarged view of the distal lens system;

FIG. 13 is a graph of the sine of the maximum ray angle versus normalized image height for different lens systems for the distal end of the endoscope;

FIG. 14 is an enlarged view of another embodiment of a distal lens system;

FIG. 15 is a sectional view of another embodiment of an endoscope;

15 FIG. 16A is a sectional view of the endoscope taken along line 16A-16A of FIG. 15;

FIG. 16B is a sectional view of the endoscope taken along line 16B-16B of FIG. 15;

20 FIG. 16C is an enlarged sectional view of the imaging unit as indicated by the portion defined by 10C in FIG. 16B;

FIG. 17A is a sectional view of another embodiment of an endoscope;

FIG. 17B is a sectional view of the endoscope taken along the line 17B-17B of FIG. 17A;

FIG. 18 is a side view of a two-part disposable sheath/illuminator unit;

25 FIG. 19 is a schematic of a control unit for a preferred embodiment of the invention; and

FIG. 20 illustrates a preferred method of using the invention.

DETAILED DESCRIPTION OF THE INVENTION

An embodiment of the invention is illustrated in FIG. 1 that shows a miniature endoscope 20. The endoscope 20 has an imaging unit 22 and a sheath/illuminator unit 24. The endoscope 20 has an image transmission path such as a plurality of optical fibers 26, as best seen at fibers 146 in FIGS. 11 and 12, in an elongated tube 28 of a rod tip 29 used to view objects to be examined. The optical fibers 26 are optically coupled to an imaging device 30, such as a charged coupled device as seen in FIG. 9, or other pixilated flat panel sensor, in a handle 32. A disposable sheath 34 of the sheath/illuminator unit 24 overlies the elongated tube 28 of the rod tip 29, which contains the optical fibers 26. The disposable sheath 34 has at the proximal end a base 35 with a mounting mechanism 36 for securing to the handle 32. In one embodiment, the disposable sheath 34 of the sheath/illuminator unit 24 has a plurality of optical fibers for transmitting light to the distal end of the disposable sheath 34 and the distal probe 29. The distal end of the disposable sheath/illuminator unit 24 has a connection 38 to connect to a light source 40.

The handle 32 can house a power input 41, used to provide power to the endoscope 20. It is recognized that the light source 40 and/or power source can be mounted within the handle 32.

The handle 32 can also house an image output 42. The image output 42 provides a connection between an imaging device in the imaging unit 22 of the endoscope 20 and an electronic storage and/or display device. In one embodiment, the storage device is a computer 44, which is connected to a monitor 46. A control unit 250 is described in greater detail with respect to FIG. 19.

As explained below in greater detail the imaging unit 22 does not need to be sterilized in that the imaging unit 22 does not contact or is in direct exposure to the body. The sheath/illuminator unit 24 has the disposable sheath 34 that is a sleeve assembly 52 that is carried by the base 35 secured to the imaging unit 22 that overlies the elongated tube 28 to create a sterilized barrier. In addition, the sheath/illumination unit 24 has a sterilized drape 52 which is mounted to the base 35 of the sheath/illuminator unit 24 and is positioned to overlies the remaining portion of the imaging unit 22 to provide a sterile environment.

Endoscopes and endoscopes with disposable sheaths are described in PCT Publication WO 01/19235 published on March 22, 2001.

5 Prior to discussing the endoscope 20 in further detail, in order to use the endoscope 20, the endoscope 20 needs to be positioned in the body to view the desired location. One such method is to insert a cannula 60 into the body and thread the endoscope 20 through the cannula 60. One method of inserting the cannula 60 into the body and then inserting the endoscope 20 into a body using the cannula 60 is
10 described below.

 During an insertion procedure, a cannula 60 such as seen in FIG. 2, is first inserted into a site within a body. The cannula 60 has a base 62 and a tube 64. The tube 64 has a shaft 66 which extends from the distal end 68 to a void 70 in the base 62. In one embodiment, the tube 64 is made of a flexible material such as plastic or
15 thin wall stainless steel. The cannula 60 has a luer 72 for insertion of medications or fluids or for attachment to a suction device.

 For insertion of the cannula 60 into the body, a trocar 76, as seen in FIG. 3, is inserted into cannula 60 with a rigid shaft 78 of the trocar 76 received within the shaft 66 of the cannula 60. The rigid shaft 78 of the trocar 76 extends slightly beyond the
20 distal end of the tube 64 of the cannula 60 and has a stylet 80 to cut into the tissue at the surgical site if necessary. Once the cannula 60 is positioned at the surgical site, the trocar 76 is removed from the cannula 60 and the endoscope 20 is installed. The cannula 60 is positioned by the user's hands feeling the location.

 While the cannula 60 and trocar 76 are of a relative minimal cost and can be
25 reused after sterilization or disposed of after use, because of several components in the endoscope 20 such as components in the imaging unit 22, it is not desirable to dispose of the entire endoscope 20. The endoscope 20 uses a disposable sleeve or sheath 34 to aid in maintaining a sterile environment and reduce or eliminate the sterilization requirements prior to reuse.

30 With the method of inserting the endoscope 20 into the cannula 60 to have the distal end of the endoscope 20 at the proper location, previously described, the endoscope 20 is described in further detail. Referring to FIG. 4, a perspective view of

the endoscope 20 is shown. The endoscope 20 has the reusable imaging unit 22 and the disposable sheath/illuminator unit 24. The disposable sheath/illuminator unit 24 has a elongated tube for overlying and encircling the elongated tube 28 of the imaging unit 22. The elongated tube of the sheath/illuminator unit 24 has a sealed distal end 84 and several embodiments includes fiber optics for transmitting the illumination from a external light source 40, such as seen in FIG. 1, to the distal end 84. At the proximal end of the sheath/illuminator unit 24 is a base 35 with a mounting mechanism 36 for securing to the imaging unit 22 of the endoscope 20. An optical pigtail 88 projects from the base 35 for connecting to the light source 40. In addition, the sheath/illuminator unit 24 has a the drape 52 which is mounted to the base 35 and is extended over the handle 32 of the imaging unit 22. The handle 32 of the imaging unit 22 contains optics and the imaging device 32 to receive the image transmitted through the optical fibers 26 located in the elongated tube 28 of the imaging unit 22 as described in further detail below with respect to FIGS. 9 - 11.

FIG. 5 is a sectional view of the miniature endoscope 20 including the reusable imaging unit 22 with imaging an optical fiber 26 and the disposable sheath/illuminator unit 24. The cannula 60 is shown overlying the disposable sheath 34 of the sheath/illuminator unit 24, which overlies the probe 29 of the imaging unit 22.

As seen in FIG. 5, the reusable imaging unit 22 of the endoscope 20 is encircled by the disposable sterile sheath/illuminator unit 24. The disposable/sheath illuminator unit 24 has the disposable sheath 34 that is sealed at the distal end 84 and encircles and surrounds the elongated tube 28 carrying the optical fibers 26 of the imaging unit 22. The mounting mechanism 36 on the base 35 of the sheath/illuminator unit 24 is secured to a mounting mechanism 92 on the imaging unit 22.

The disposable sheath/illuminator unit 24 has the drape 52 which surrounds the handle of the imaging unit 22. In addition, the sheath/illuminator unit 24 has the illumination pigtail connecting to a light source 40 as seen in FIG. 1. The illumination pigtail 88 is optically coupled to the optical fibers in the sheath as explained in further detail below.

-8-

Referring to FIG. 6A, a side view of the sheath/illuminator unit 24 is shown. The sheath unit 24 has the disposable sheath 34 with an elongated outer sheath 98 which extends from the base 35 to the distal end 84. The illuminator pigtail 88 extends from the base and is optically coupled to illumination fibers within the sheath 34 as seen in FIG. 7A. The drape 52 is carried by the base 35 of the sheath/illuminator unit 24 for overlying the handle 35 of the imaging unit 22 when the two units 22 and 24 are combined.

FIG. 6B is an enlarged view of the distal end 84 of the disposable sheath 34 of the sheath/illuminator unit 24. The disposable sheath 34 has the outer sheath 98 which extends from within the base 35, as seen in FIG. 6A, and serves as protective covering and a sterile barrier for the sheath unit 24. Spaced and collinear with the outer sheath 98 is an inner tube 100 of the disposable sheath 34. The inner tube 100 defines a cylindrical void or space 102 for receiving the elongated tube 28 of the probe 29 of the imaging unit 22. The inner tube 100 likewise extends from the distal end 84 of the disposable sheath 34 to the base 35 of the sheath/illuminator unit 22. The inner tube 100 extends further than the outer sheath 98 to create a channel 106 to receive a plurality of illumination fibers 108 as best seen in FIG. 6A and 7A. At the distal end, of the inner tube 100 is located a window 110 which is secured to the inner tube 100 to make a sterile barrier between the airspace 102 for receiving the elongated tube 28 of the image unit 22 and the outer portion of the sheath/illuminator unit 24 which is in contact with the body.

In a preferred embodiment, the outer sheath 98 of the disposable sheath 34 of the sheath/illuminator unit 24 is made of a stainless steel material and has an outer diameter of about 0.038 inches. The inner tube 100 is likewise made of a stainless steel material. The illumination fibers 108 are made of a glass or plastic fiber. Depending on the size of the device, the maximum number of illumination fibers 108 used to fill channel 106. In one example, the disposable sheath 34 extends 2.246 inches from the base 35 of the sheath/illuminator unit 24.

Interposed between the outer sheath 98 and the inner tube is the plurality of illumination fibers 108 which encircle the inner tube 100 as best seen in FIG. 7A and 7B. FIG. 7A is a sectional view through the base 35 of the disposable sheath 24. The outer sheath 98 is shown in the lower half of FIG. 7A and terminates prior to the

portion sectioned in the upper half of FIG. 7A. The inner tube 100, however, which defines the airspace 102 to receive the elongated tube 28 of the imaging unit 22 extends to a receiving chamber 114 as seen in FIG. 6A and therefore is shown in both the upper and lower portions of FIG. 7A. The light is transmitted from the illumination pigtail 88 through fibers 108, as seen in FIG. 6A, to a transmission unit 118 as seen in the upper half of FIG. 7A which abuts the illumination fibers 108 located between the outer sheath 98 and the inner tube 100 of the disposable sheath 34 of the sheath/illuminator unit 24.

FIG. 7B shows the distal end 84 of the disposable sheath/illumination unit 24. The window 110 overlies and seals the airspace 102 that receives the imaging unit 22 and is encircled by the inner tube 100. Interposed between the outer sheath 98 and the inner tube 100 is the plurality of illumination fibers 108. In the embodiment shown, the distal end of the illumination fibers 108 are not protected and exposed to the body.

FIG. 8 is similar to FIG. 6A in that it shows the disposable sheath/illumination unit 24. In addition, FIG. 8 shows the entire illumination pigtail which is broken away in FIG. 6A.

The illumination pigtail 88 has a connection 38 for connecting to a connector on the light source 40. The illumination pigtail 88 has a plurality of optical fibers which run from the connection 38 to the fibers 108 which transmit the light received from the light source 40 to the transmission unit 118 shown in FIG. 7A and exit at 84.

Referring to FIG. 9, a sectional view of the imaging unit of the endoscope is shown. The imaging unit 22 has the probe 29 with the elongated tube 28 that extends from the handle 32. At the proximal end of the handle 32, is the imaging device. In this embodiment, a charged coupled device (CCD) 30B which converts the optical image into an electrical image is carried in the detachable housing 120A of the handle 32. Interposed between the optical fiber or fibers 26 which extend in the elongated tube 28 and the CCD 30B is a plurality of lenses 122A for projecting the image of the proximal end 124 of the optical fiber or fibers 26 to the CCD 30B. The glass window 122B is attached to housing 120B and provides a seal to the scope. It also protects the lenses from contamination.

-10-

The imaging unit 22 enlarges the image from the end of the fiber optic 26 and couples it to the charged coupled device 30B. As indicated above, the charged coupled device is connected to a electronic storage and/or display device such as a computer 44 which is connected to a monitor 46 as seen in FIG. 1.

5 The handle 32 of the imaging unit 22 has a mounting mechanism 128 for coupling with the mounting mechanisms 36 of the sheath illuminator unit 24. The mounting mechanism 128 has slots 130 for receiving pins located on the mounting mechanisms 36. In addition, the mounting mechanism 128 has a projection 134, from which the probe 29 projects, that is received by the receiving chamber 114 of
10 the sheath/illuminator unit 24 as seen in FIG. 6A.

An enlarged view of the distal end of the imaging unit 22 is shown in FIG. 10A. The rod tip 29 of the imaging unit 22 has the elongated tube 28 that extends from the distal end 126 to the housing 120 of the handle 32. At the distal end 126 of the rod tip 29 there is in addition a tube 138 which extends a slight distance from the
15 distal end 126 and just a slight distance beyond the ends of the optical or image fibers 26. The tube 138 is commonly referred to as the long tube in that a shorter and smaller diameter tube 140 which is collinear with the long tube 138 is received within the long tube 138 and extends a lens system 142 at the distal end 126. The elongated
20 or outer tube 128, long tube 138 and small tube 140 are mounted so that their distal ends are flush and are secured by an adhesive such as a medicalgrade epoxy. At the end of the elongated tube 28 of the imaging unit 22 is the lens system 142 that is described in further detail below. The elongated tube 28 of the imaging unit 22 is received within the disposable sheath/illumination unit 24 and therefore does not need to be sterilized prior to the
25 first use.

FIG. 10B is an end-view of the distal end 126 of the imaging unit 22. The lens system 142, the small tube 140, the long tube 138 and the outer or elongated tube 28 are shown and are all collinear.

Referring to FIG. 11, a sectional view of the imaging unit 22 of the endoscope
30 20 is shown. The probe 29 of the imaging unit 22 has a plurality of fibers 146 for transmitting the image from the distal end 126 of the rod tip 29 to the handle 32. Encircling the fiber 146 at the distal end of the rod tip 29 is the long tube 138 for

-11-

holding the fibers 146 of the image fibers 26 in position. The outer or elongated tube 28 encircles the long tube 138 and protects the fibers 146 of the image fibers 26 from their beginning near the distal end 126 of the rod tip 29 to the other end within the handle 32. There are typically thousands of fibers 146 as shown in FIG. 11 that are fused together. The loading of the image into them is done by the distal end lens system 142 which as described below arranges the light levels of the image in a relationship to the location of the image fiber bundle 26.

In addition, the fibers are in a disorder pack method. This disorder pack method limits transmission of images/light from one lens 142 to another as the image fiber bundle 26 extends from near the distal end 126 of the imaging unit 22 towards the proximal end of the fibers located within the handle 32. The disorder packing of fibers is achieved by varying the doping of the fibers, which is the area to be examined.

Referring to FIG. 12, a sectional view of the distal end of the rod tip 29 of the imaging unit 22 within the disposable sheath 34 of the sheath/illuminating unit 24 is shown. The disposable sheath 34 has the outer sheath 98 collinear with the inner tube 100. Interposed between the outer sheath 98 and the inner tube 100 is the plurality of illumination fibers 108 as best seen in FIG. 7B for illumination. At the distal end of the disposable sheath is the window that is secured, such as by cementing, to create a boundary to the air space or inner channel 102 that receives the rod tip 29 of the imaging unit 22. The imaging unit 22 has the elongated or outer tube 28 that extends from the distal end 126 to within the handle 32 as shown in FIG. 9. Located in the distal end 126 of the rod tip 29 are two additional tubes or sleeves, the shorter inner sleeve, referred to as the small tube 140, that retains and holds the lens elements of the distal lens system 142. A larger longer sleeve, referred to as the long tube 138, encircles the tube 140 and the beginning of the fibers 146 of the image fibers 26.

The distal lens system 142 as shown in FIG. 12 is an achromatic lens system having a pair of lenses 150 and 152 and an aperture stop 154. The lenses 150 and 152 each have a convex surface 156 that faces each other. The second lens 152, closer to the distal end 126, has a planar surface 158 which abuts the optical aperture stop 154. The aperture stop 154 and the lenses 150 and 152 are designed so that the sine of the maximum ray angle approaches the fibers at N.A. (numerical aperture).

-12-

The ray tracings 160 in FIG. 12 illustrate the projection of an image off the page to the right at the proper focal length and how this image is translated through the aperture stop 154 and through the lenses 152 and 150 to the plurality of fibers 146 in the image fibers 26. The lens system is non-telecentric.

5 Referring to FIG. 13 a graph of the sign of the maximum ray angle versus the normalized image height for three different lens systems including a prior art lens system is shown. As discussed below, the field of view is dependent upon the lens configuration. The graph in FIG. 13 shows a line for the maximum sign of a ray angle for a 50 degree lens system and a second line for a maximum sign of ray angle
10 of a 70 degree lens system. In the 70 degree system, the maximum sign is approximately 0.32. Therefore, the N.A. (numerical aperture) of the fiber is approximately the same. In contrast, the 50 degree field of view system has an sign of a maximum ray angle of approximately 0.25. Therefore, the fibers have this numerical aperture. The system can provide a field of view at any selected level from
15 30-80 degrees, for example.

In one embodiment, the endoscope 20 has 10,000 fiber elements. In this embodiment, each fiber element 146 has a diameter of 4.4 microns. The overall diameter of the fiber 26 is 0.46 mounting mechanism. The elongated or outer tube 28 of the imaging unit is made from stainless steel. It is recognized, that the scope can
20 be formed in many sizes, the following table is merely an illustration of various intervening size scopes.

	3k	10k	30k	50k	100k
Sheath/ Illumination unit outer diameter	1-4 mm				
Imaging Unit rod tip outer diameter	0.5-3.5 mm				
No. of fiber elements	3,000	10,000	30,000	50,000	100,000
Fiber image diameter		0.46 mm	0.75 mm		
Fiber pixel size (individual fiber)	4.4 microns	4.4 microns	4.4 microns		
Lens Type	Achromatic or Selfoc Grin	Achromatic or Selfoc Grin	Achromatic	Achromatic	Achromatic
Depth of Field (DOF)		3 mm-20 mm			
Field of View (FOV)	Dependent on Lens 50° - 70°				

As can be seen from table above, an alternative to an acromat lens described above with respect to FIG. 12 and 13 is a selfoc grin lens. FIG. 14 shown an alternative embodiment of the rod tip 29 of the imaging unit 22 of the endoscope 20 with a grin lens 168. The grin lens 168 as shown in FIG. 14 is a single element gradient index lens. The rod tip 29 of the image unit 22 as shown in FIG. 14 has an elongated or outer tube 28 that extends from the distal end 126 to the handle 32, not shown in FIG. 14. In addition, similar to that of FIG. 10A, a tube 138 extends a slight distance from the distal end 126. This tube 138 is commonly referred to as the long tube, it extends just slightly beyond the ends of the optical image fibers 26. In contrast to the embodiment shown in FIG. 10A in that the lens 170 is a single lens there is no need for a small tube 140 for retaining the elements of a lens system.

The grin lens 168 in general does not provide as good of image quality as that of the acromat lens system 142 described above in that the image becomes less clear

-14-

(i.e., blurry and distorted) towards the edge of the image. In addition, the color correction, changes in intensity as a function of wavelength, is not as good as in the acromat lens system. However, the GRIN lens system 168 maybe desirable in situations where cost is a higher factor than the overall image quality. In addition, because of the grin lens 170 being a single element lens the depth of fields may be limited. While only 2 different degrees of freedom are shown, it is recognized that lens systems with other fields of view can be made.

FIG. 15 is a sectional view of alternative endoscope 170. In this embodiment of the endoscope 170, the illuminator pigtail 172 is a part of the handle 174 of the imaging unit 176 and is therefore not part of a disposable sheath/illuminator unit 178. An optical fiber bundle 180 is used for transmitting the illumination light from the pigtail 172 to a handle interface 182 in the handle 174 where the light is transferred to a light interface 184 on the sheath/illuminator unit 178 to transmit light from the handle 174 to the disposable sheath 186.

FIG. 16A is a sectional view showing the interface. FIG. 16A is a sectional view of the base 188 of the disposable/sheath illuminator unit 178. The upper portion of FIG. 16A shows the drape 52 spaced from the base 188. The base 188 has a light interface 184 that receives light from the handle interface 182 carried on the handle 174.

In addition in the embodiment of the endoscope 170 shown in FIGS. 16A-16C, the sheath/illuminator unit 178 has one of the illumination fibers 190 replaced by a tube or channel 192. The tube 192 which is seen in FIGS. 15 and 16A-16C is capable of receiving a laser fiber. The user passes a laser fiber through the tube 190 from the proximal end of the illumination unit 178 in the base 188 as seen in FIG. 15, to the distal end of the illumination unit so that the user while viewing the image through the imaging fibers and CCD can complete a process using the laser fiber.

The lower half of FIG. 16A shows a cross-sectional view through the base 188 of the sheath/illuminator unit 178 shows the tube 192 extending through the base into the annular ring containing the illumination fibers 190. Similar to that shown in FIG. 7A, FIG. 16A shows an inner tube 194 around which the illumination fibers 190 are located. The inner tube 194 defines an airspace through which the probe 29 of the imaging unit 176 of the endoscope 170 passes.

-15-

FIG. 16B is a sectional view of the disposable sheath 186 showing an outer tube 196 of the disposable sheath 186 and circling the illumination fibers 190 and a signal hypotube 192. The inner tube 194 surrounds the airspace 102 which receives the probe 29 of the imaging unit 176. FIG. 16C is an enlarged view showing the
5 hypertube 192 with its opening to receive the laser fiber in the annular ray containing the illumination fibers 190 between the inner tube 194 and outer sheath 196.

While FIGS. 15-16C do not show a cannula 60, it is recognized in most uses of the endoscope 20 or 170, a cannula 60 can be used for extra protection of the endoscope 20 or 170.

10 Referring to FIG. 17A, a sectional view of an alternative endoscope 200 is shown. The endoscope 200 has an imaging unit 202 and a sheath unit 204. In contrast to the previous embodiments, the sheath 204 that is disposable does not include any part of the illumination unit. Referring to FIG. 17A, the illumination
15 source 40 is connected to the handle 206 of the imaging unit 202 by an illumination pigtail 208 similar to that shown in FIG. 15. But in contrast, there is no coupling such that that the light is transmitted to the disposable sheath 204. Rather, as seen in FIG. 17A, the illuminator pigtail 208 is a part of the handle 206 of the imaging unit
20 202. An optical fiber 210 is used for transmitting the illumination light from the pigtail 208 to an interface 212 in the handle 206. The interface 212 is located within the handle 206 and transfer the light to an annular ring 214 of a plurality of illumination fiber 216.

Referring to FIG. 17B, the probe 218 has an outer tube 220 and an inner tube 222. Interposed between the tubes 220 and 222 is the annular space for receiving the plurality of illumination fiber 216. Located in the inner tube 222, which is similar to
25 the elongated tube 28 in the first embodiment, is the image fiber bundle 26. The fiber bundle 26 is spaced from the inner tube 222. A long tube 224, which extends for a slight distance from the distal end 126 to just beyond the ends of the image fiber bundle 26, is interposed between the fibers 26 and the inner tube 222.

In that the sheath is not required to carry illumination to the distal end of the
30 rod tip 218 in the embodiment shown in FIGS. 17B, the sheath 204 has a single outer layer 226. A window curved to avoid retroreflection is secured to the distal end of the single outer layer 226.

-16-

Referring to FIG. 18, a two piece disposable sheath/illuminator unit 230 is shown. The endoscope has a first unit 232 of the two piece disposable sheath/illumination unit 230, a mounting and cover unit 232, that is mounted to the handle 32 of the imaging unit 22. The mounting and cover unit 232 has a drape 52 that extends over the handle 32 of the imaging unit 22 and the illumination pigtail 88 when used. The drape 52 is retained on a disposable sleeve 234 to hold the drape 52 until positioned over the handle 32. The second unit 236 of the disposable sheath/illumination unit 230, a disposable sheath 236, contains the elongated tube that covers the probe 29. This second unit 236 has a mounting mechanism 238 to secure to the first unit 232. It is therefore possible to remove the disposable sheath, the second unit, 236 and replace it with a new one while keeping the drape 52 that is mounted to the mounting and cover unit 232 over the handle.

FIG. 19 is a schematic of a control unit 250 for the endoscope. This control unit 250 has a power source output 252, an input 254 for the image from the CCD and a light source 256. In addition to a processing unit 260 for processing the image data, the unit has a recording device 258 such as a CD writer to create a storable medium to retain data such as a baseline for the patient.

The endoscope is used as shown generally in the process sequence 270 of FIG. 20. The patient comes to the user/physician's office. The physician or technician uses a double gloved technique where two sterilized gloves are placed on each of the physician's hands. The physician takes the handle/illuminator unit which is not sterilized in one hand and secure the sterilized sheath/illuminator unit with the other hand. The physician then takes the lighting cord and secure the light cord to the pigtail on the disposable sheath/illuminator unit. The power and image output are likewise connected to the control unit. With the endoscope connected to the control unit, the drape portion of the sheath assembly is extended 272 over the handle and down the cords to such a length to provide a sterile field. With this completed, the physician takes off the first pair of gloves and is ready to begin the procedure.

After medicating the site, the cannula with the trocar is inserted into the body by a standard technique of probing with the physician's hand. Once the cannula is in position, the trocar is removed 274 and the tip of the endoscope is placed into the cannula. The endoscope is secured to the cannula using a screw or other attachment

-17-

mechanism. The system is actuated 276 and video recording is initiated so that the physician is able to move the cannula in and out and around to position the probe for viewing of the desired site or a monitor. The physician can perform a procedure 278 at the site using other instruments such as a laser scalpel or cautery tool, or
5 electrosurgical tool and/or the operative channel in the probe or sheath assembly. The entire examination or operative procedure can be recorded 280 on a video disk or other memory device. The procedure is concluded and the sheath assembly can be disposed 282 of and another sterile sheath assembly can be attached 284 to the probe for another procedure.

10 While preferred embodiments have been shown and described, various modifications may be made to the processes described above. Accordingly, it is to be understood that the present invention has been described by way of example and not by limitation, and the scope of the claims should not be limited by particular examples set forth herein, but should be construed in a manner consistent with the description as a whole.

CLAIMS:

1. A disposable fiber optic sheath for illuminating a region within a body comprising:
 - a tubular sheath having an inner tube and an outer tubular surface with a diameter of less than 3 mm and a concentric array of illumination optical fibers within the sheath;
 - a window sealed at a distal end of the sheath; and
 - a hub assembly at a proximal end of the tubular sheath, the hub assembly including a connector and an optical coupler adapted for optically connecting the illumination optical fibers a light source with an endoscope handle.
2. The fiber optic sheath of claim 1 wherein the optical coupler comprises a light interface within the hub assembly.
3. The fiber optic sheath of claim 1 further comprising a sterile barrier attached to a base.
4. The fiber optic sheath of claim 3 wherein the sterile barrier comprises a drape adapted to extend over an endoscope handle.
5. The fiber optic sheath of claim 1 wherein an annular channel extends between the outer tubular surface and the inner tube, the outer tubular surface being less than 2 mm in diameter.
6. The fiber optic sheath of claim 5 wherein the optical fibers fill the annular channel.
7. The fiber optic sheath of claim 1 wherein the inner tube defines an airspace to receive an elongated tube of an endoscope imaging unit.
8. The fiber optic sheath of claim 1 wherein the optical fibers at a distal end of the sheath are not protected and are exposed to the body.

9. The fiber optic sheath of claim 1 further comprising a fluid delivery channel for delivering medication to a region of interest in a body lumen or cavity.
10. The fiber optic sheath of claim 1 further comprising a cannula adapted to receive the fiber optic sheath, the cannula comprising a fluid insertion cannula.
11. The fiber optic sheath of claim 1 wherein the connector assembly comprises a mounting mechanism adapted to attach to an endoscope handle.
12. The fiber optic sheath of claim 1 wherein the inner tube extends proximally further than an outer tube.
13. The fiber optic sheath of claim 2 wherein a proximal end of the optical fibers are coupled at a proximal end to the light interface within the hub assembly.
14. The fiber optic sheath of claim 1 wherein the sheath comprises a cover unit.
15. The fiber optic sheath of claim 14 wherein a drape is attached to the cover unit.
16. The fiber optic sheath of claim 14 wherein the cover unit is attached to a mounting mechanism.
17. The fiber optic sheath of claim 1 further comprising a receiving chamber.
18. The fiber optic sheath of claim 17 wherein the receiving chamber is within a hub assembly.
19. The fiber optic sheath of claim 18 wherein the receiving chamber extends from an airspace within the inner tube.

- 20 -

20. The fiber optic sheath of claim 2 wherein the light interface optically couples the concentric array of illumination optical fibers to an optical fiber bundle within an endoscope handle at a handle interface.
21. The fiber optic sheath of claim 1 wherein the illumination optical fibers are connected to an illumination pigtail.
22. The fiber optic sheath of claim 10 wherein the cannula has a shaft and a luer for delivery of medication.
23. The fiber optic sheath of claim 1 wherein the sheath comprises a two piece disposable sheath including a mounting and cover unit that is attached to a drape and receives the tubular sheath.
24. The fiber optic sheath of claim 1 wherein a seal is cemented to the inner tube.
25. The fiber optic sheath of claim 1 wherein an optical coupler is adapted to connect to an external light source with a light connector.
26. A disposable fiber optic sheath for illuminating a region within a mammalian body comprising:
- a tubular sheath having an outer tubular surface with a diameter of less than 2 mm and an inner tube;
 - an array of optical fibers extending between the outer tubular surface and the inner tube and defining a concentric illumination surface area at a distal end;
 - a light transmitting sealing element at the distal end of the sheath to provide a tubular cavity with an opening at a proximal end to receive an endoscope body; and
 - a hub assembly mounted at the proximal end of the tubular sheath, the hub assembly including a connector and an optical coupler that is optically coupled to a proximal end of the array of optical fibers such that the optical fibers can be connected to a light source with an endoscope handle.

27. The fiber optic sheath of claim 26 wherein the optical fibers comprise an optical fiber bundle at a proximal end that is attached to the optical coupler.
28. The fiber optic sheath of claim 26 wherein the tubular sheath comprises a rigid tube having a circular opening at the proximal end to receive an image collection tube.
29. The fiber optic sheath of claim 26 wherein the sealing element comprises a window that seals an airspace within the inner tube.
30. The fiber optic sheath of claim 26 wherein a base comprises a mounting mechanism to attach the sheath to an endoscope.
31. The fiber optic sheath of claim 30 further comprising an airspace for receiving an endoscope imaging tube having a first lens element, a second lens element and an aperture stop.
32. The fiber optic sheath of claim 26 wherein the optical coupler is adapted for optical coupling to an illumination source with an endoscope handle.
33. The fiber optic sheath of claim 26 wherein the illumination source is positioned in a control unit.
34. The fiber optic sheath of claim 26 further comprising a cannula having a fluid port.
35. The fiber optic sheath of claim 29 wherein the window is cemented to the inner tube to form an inner channel.
36. The fiber optic sheath of claim 26 wherein an annular channel extends between the outer tube and the inner tube.
37. The fiber optic sheath of claim 36 wherein the optical fibers fill the channel.

38. The fiber optic sheath of claim 26 further comprising a receiving chamber.
39. The fiber optic sheath of claim 26 wherein the connector attaches to an endoscope handle.
40. The fiber optic sheath of claim 39 wherein the endoscope handle includes an imaging device and is further coupled to a light source.
41. The fiber optic sheath of claim 39 further comprising an endoscope imaging tube that detaches from the handle.
42. The fiber optic sheath of claim 41 wherein the endoscope imaging tube comprises a first distal lens, a second distal lens, an aperture stop and a proximal lens that enlarges an image from a fiber optic imaging tube.

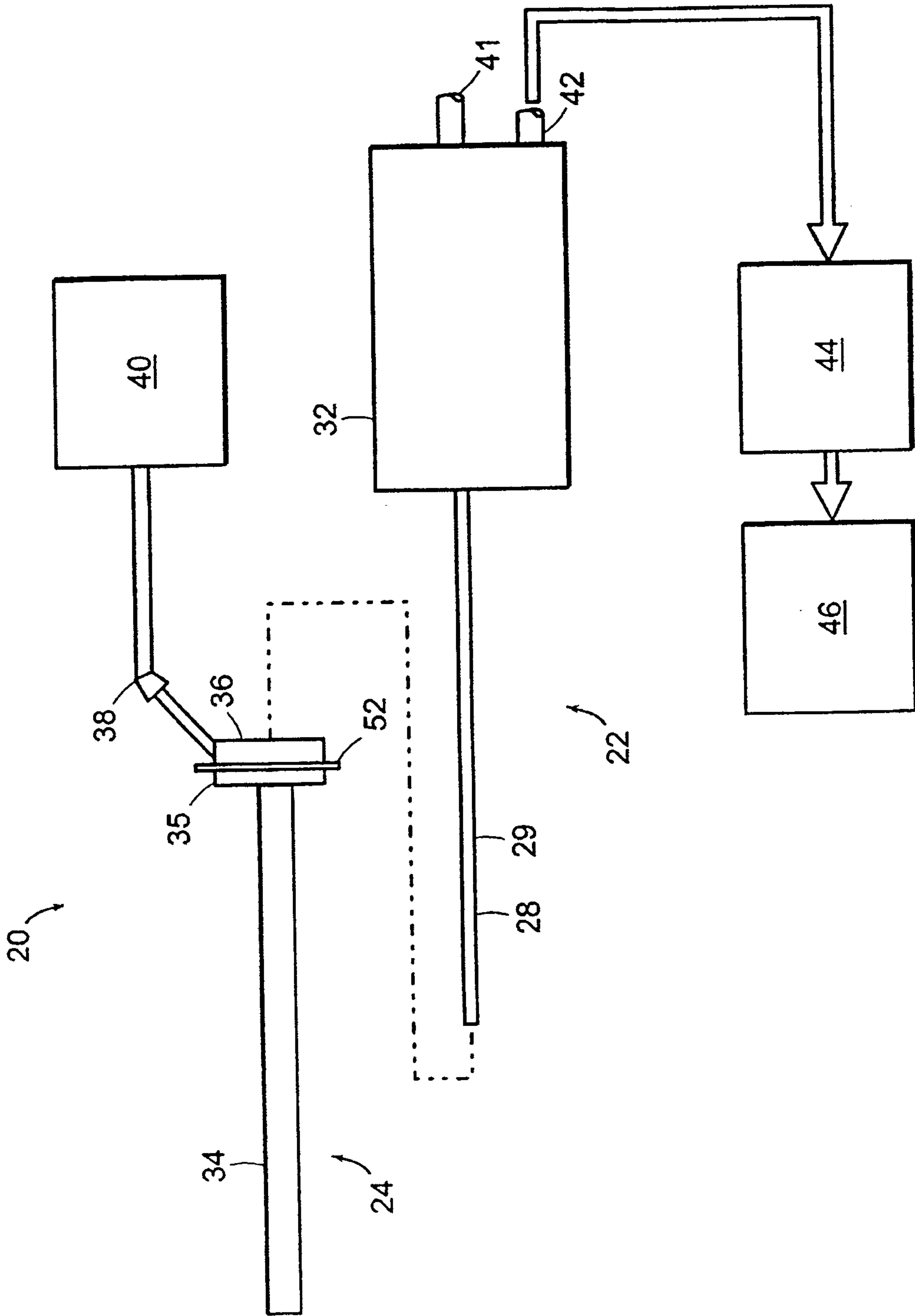

FIG. 1

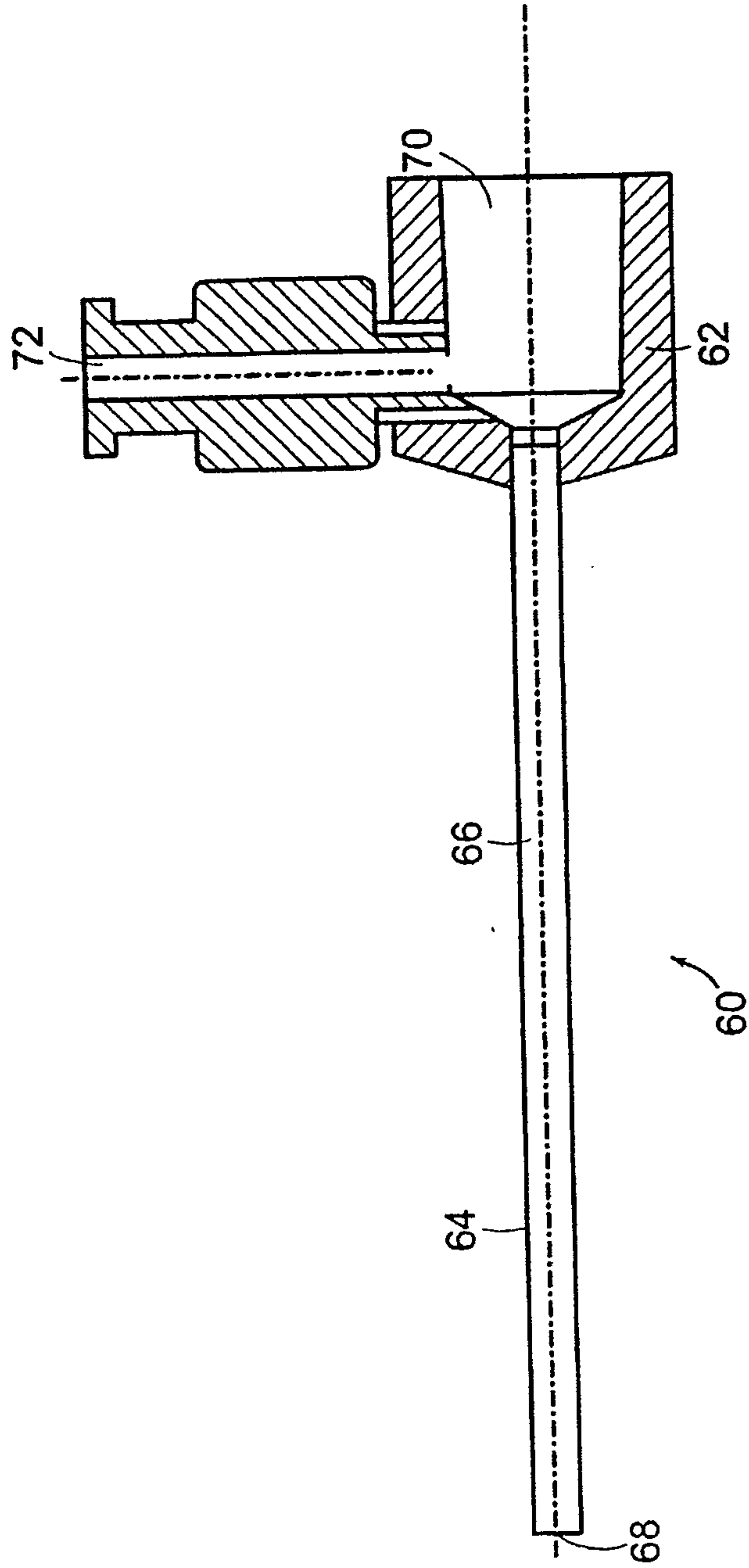

FIG. 2

3/20

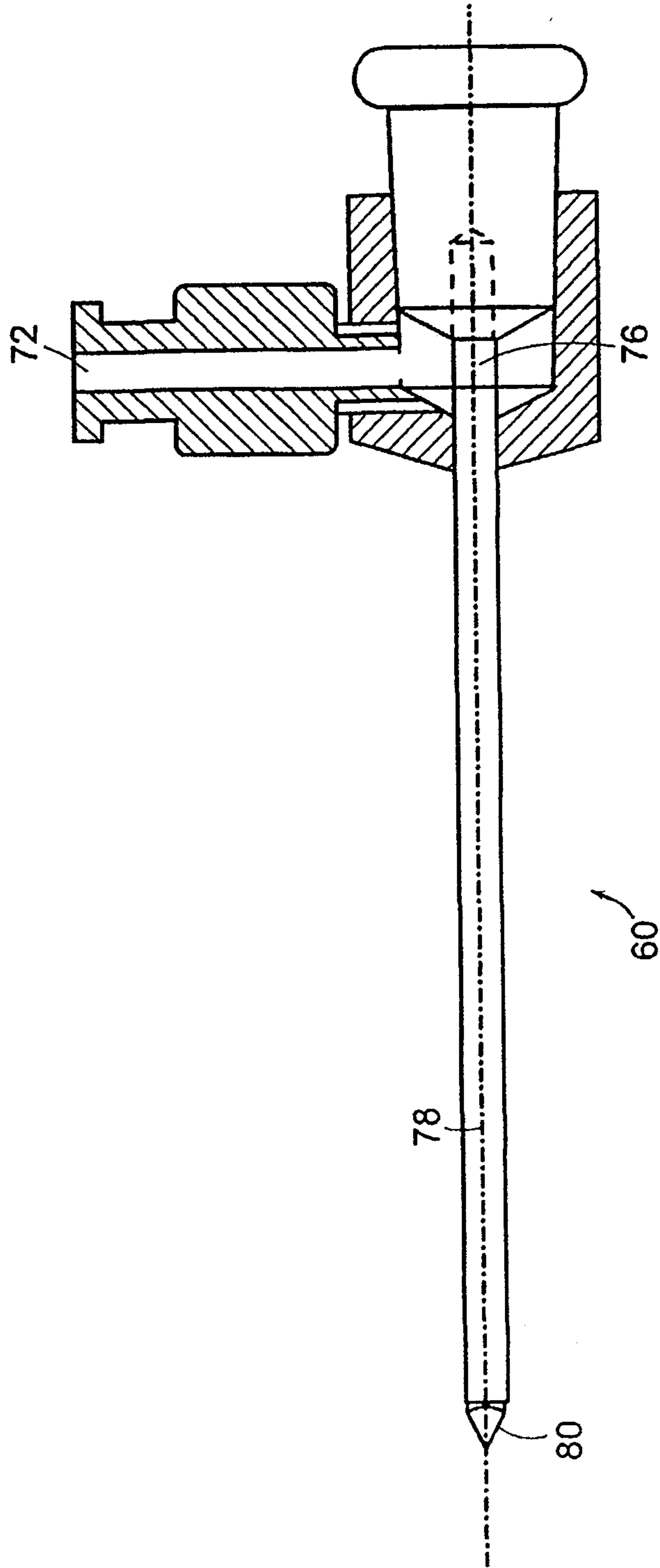

FIG. 3

4/20

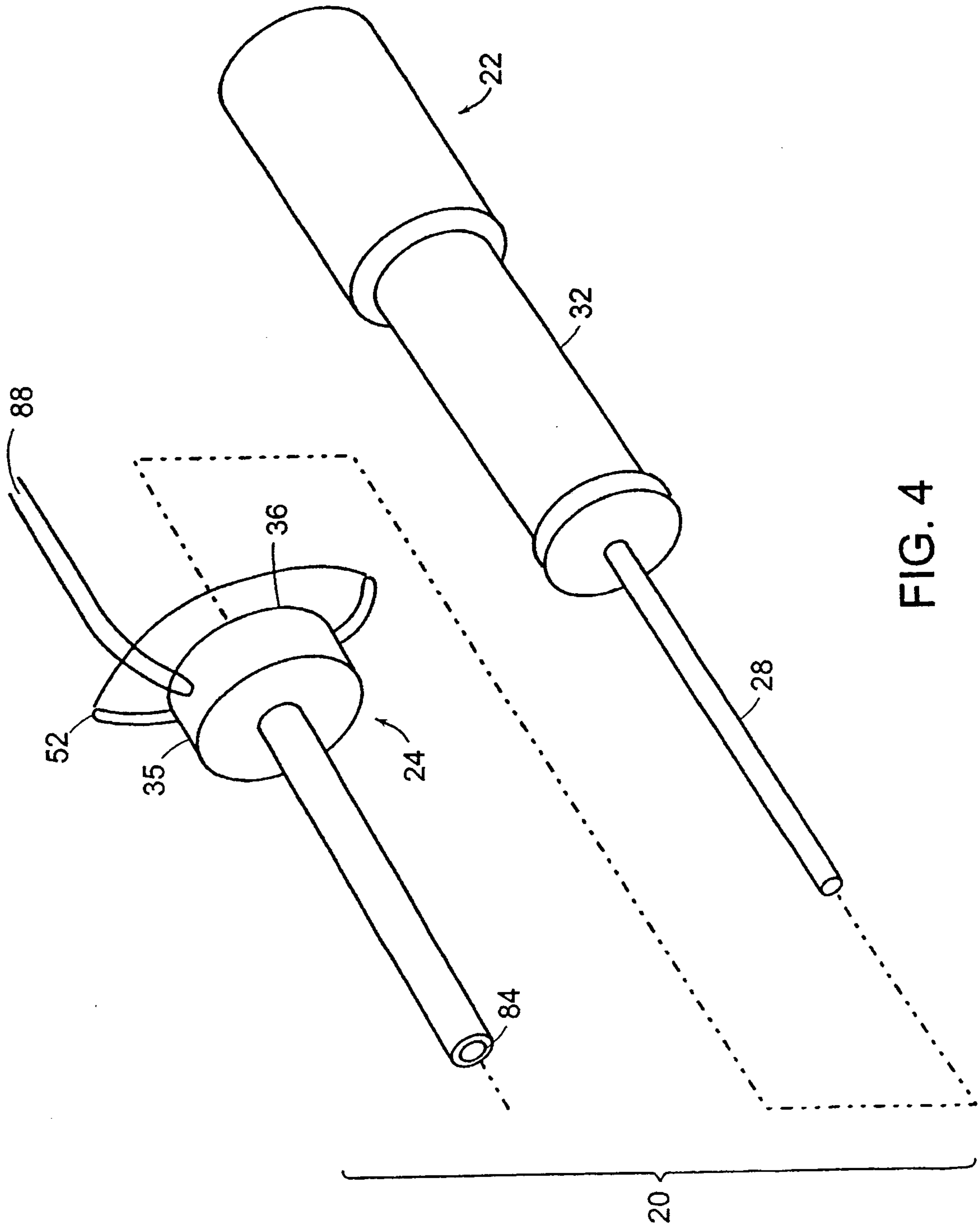

FIG. 4

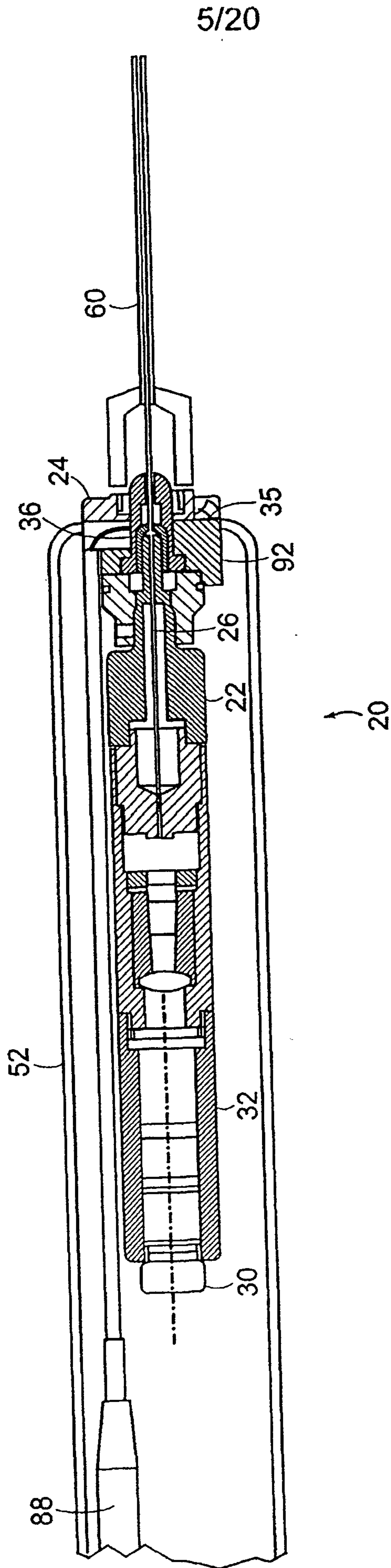

FIG. 5

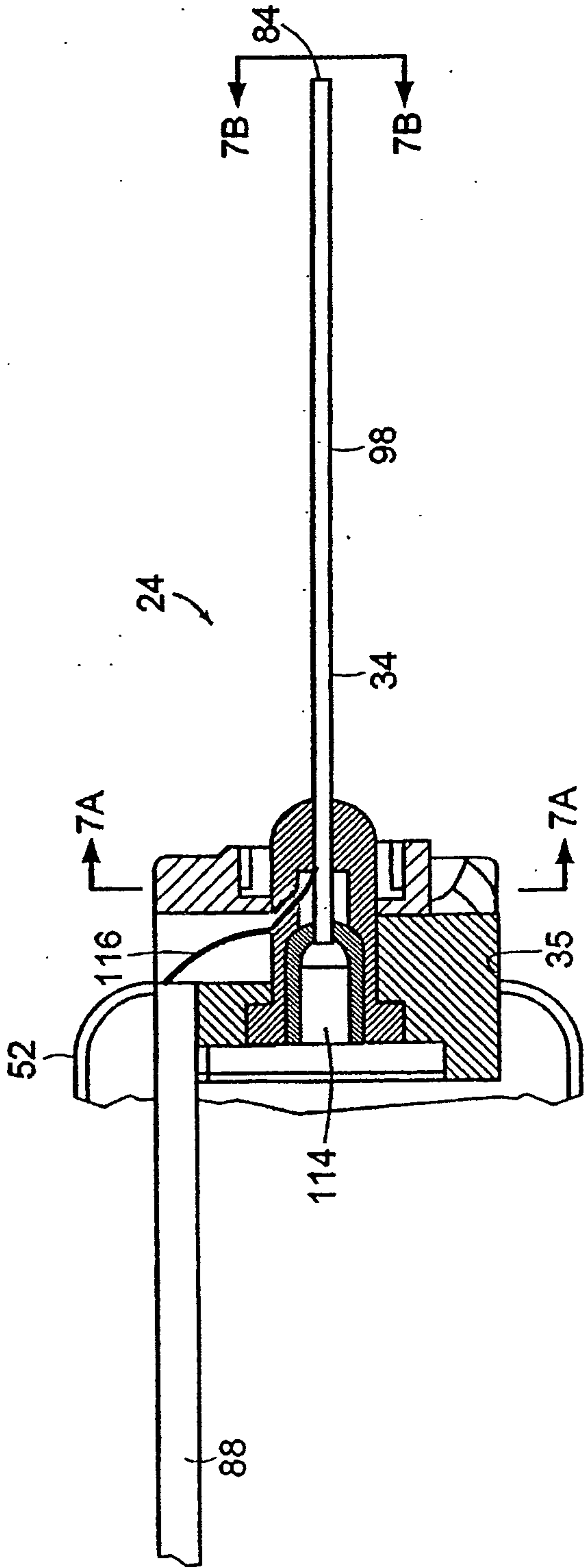

FIG. 6A

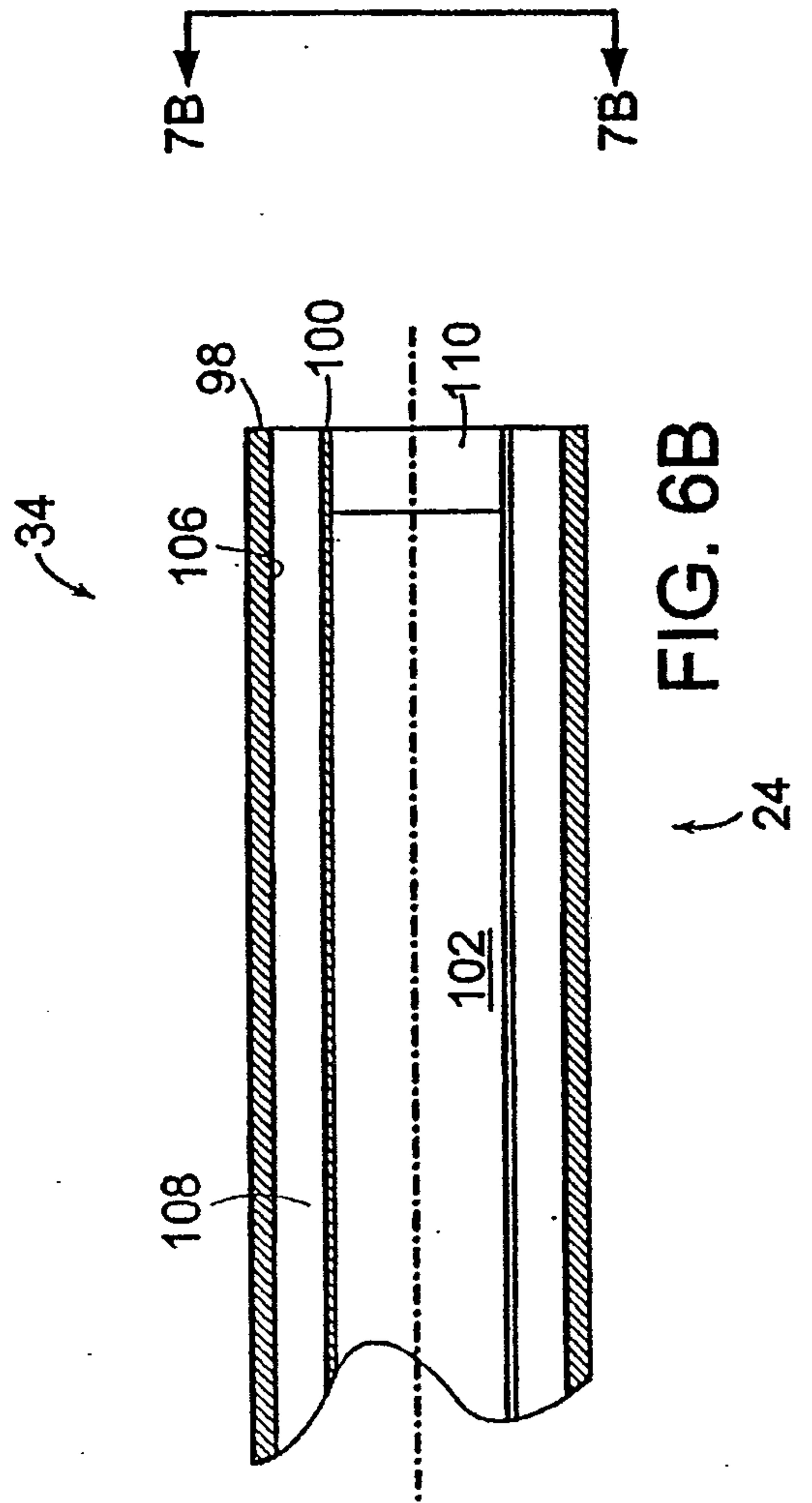

FIG. 6B

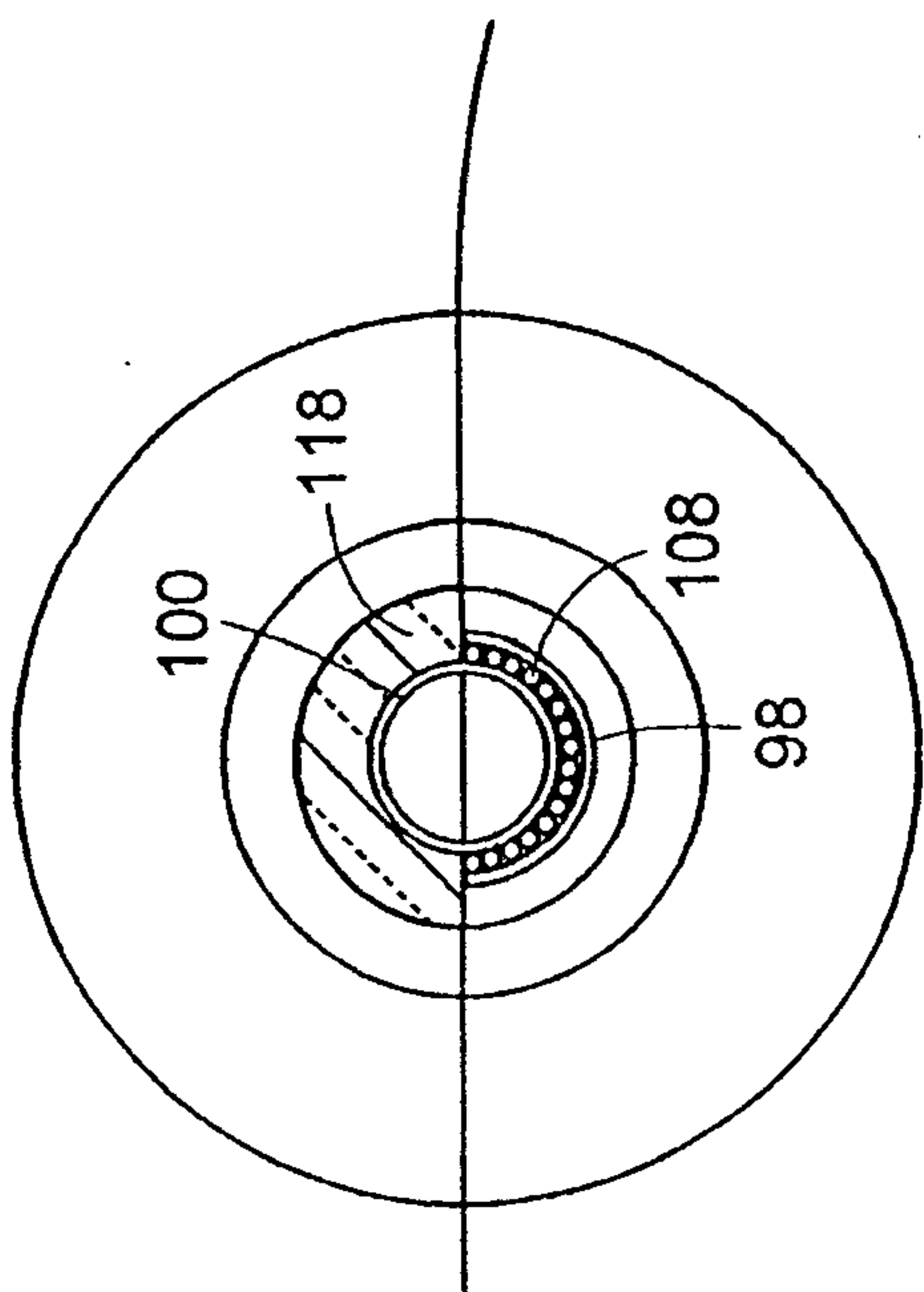

FIG. 7A

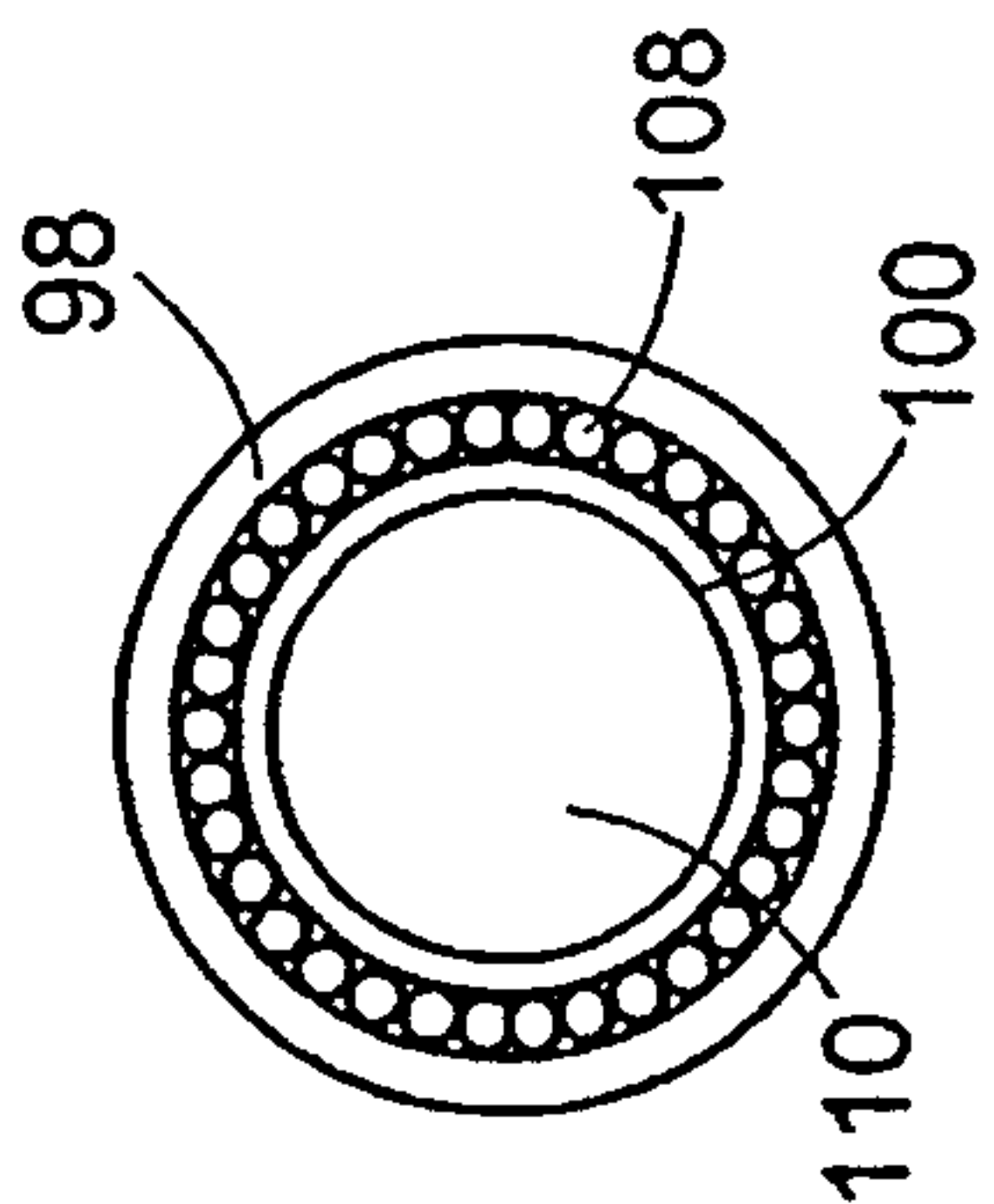

FIG. 7B

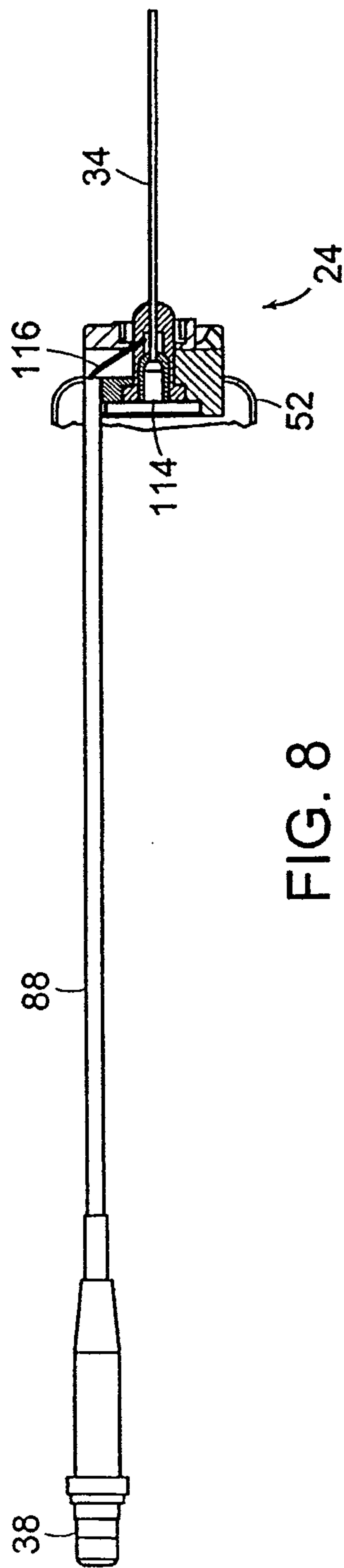

FIG. 8

8/20

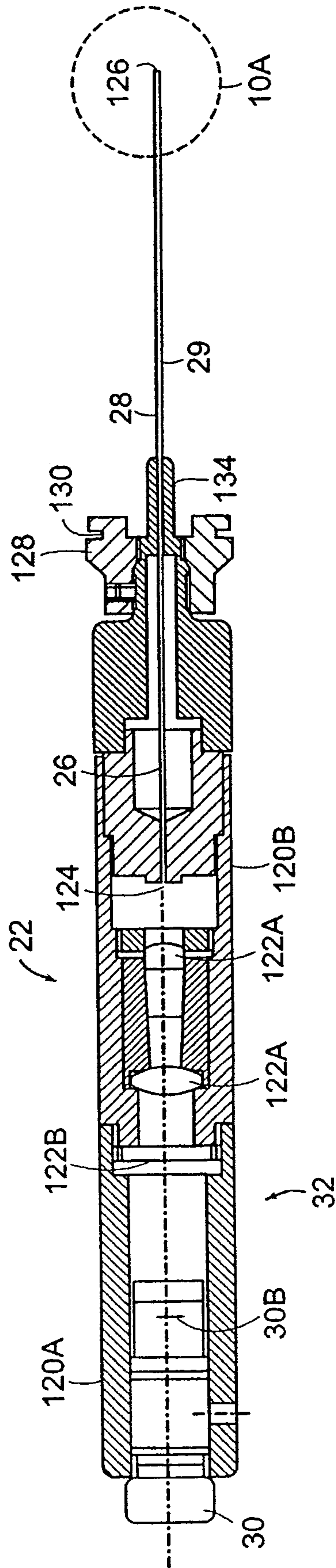

FIG. 9

9/20

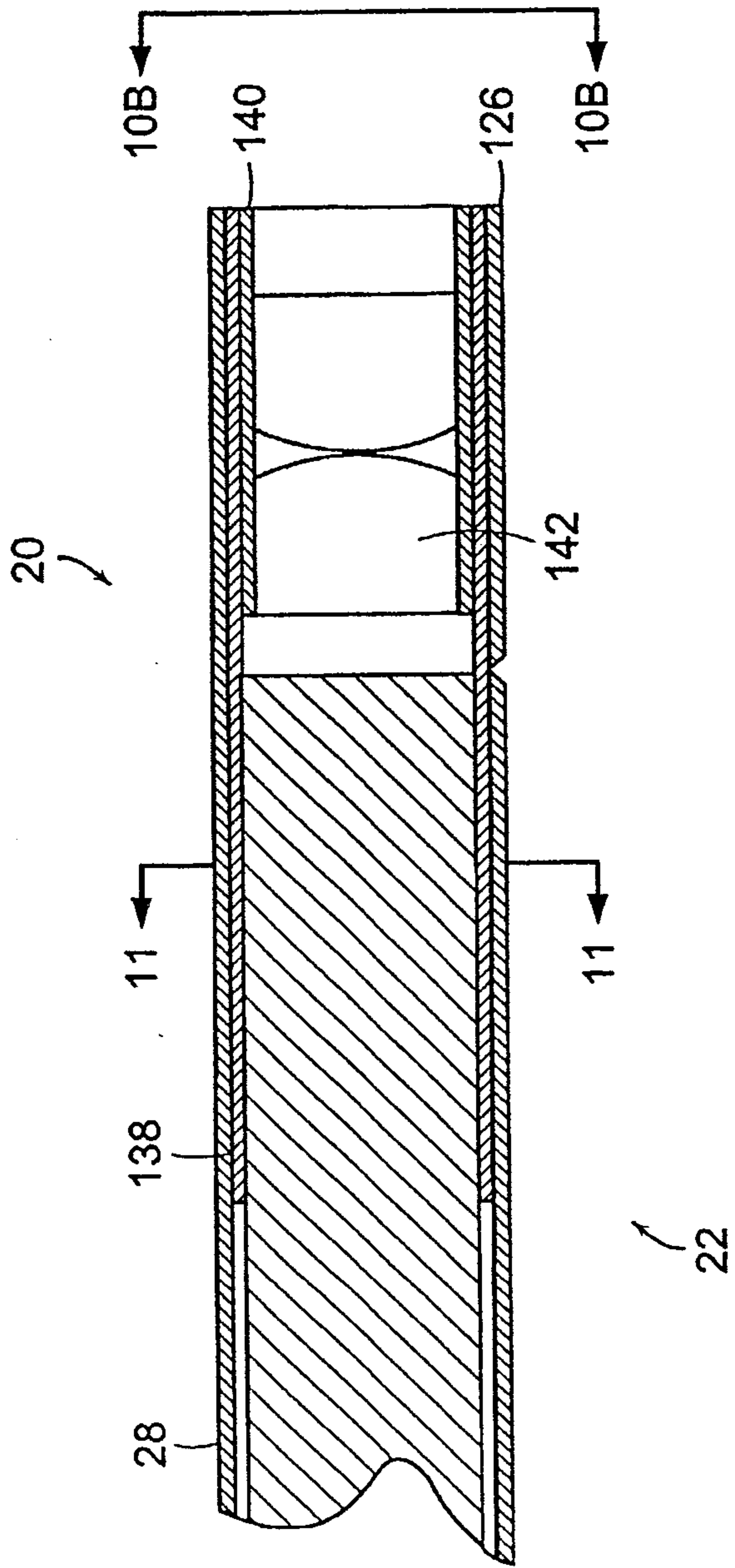

FIG. 10A

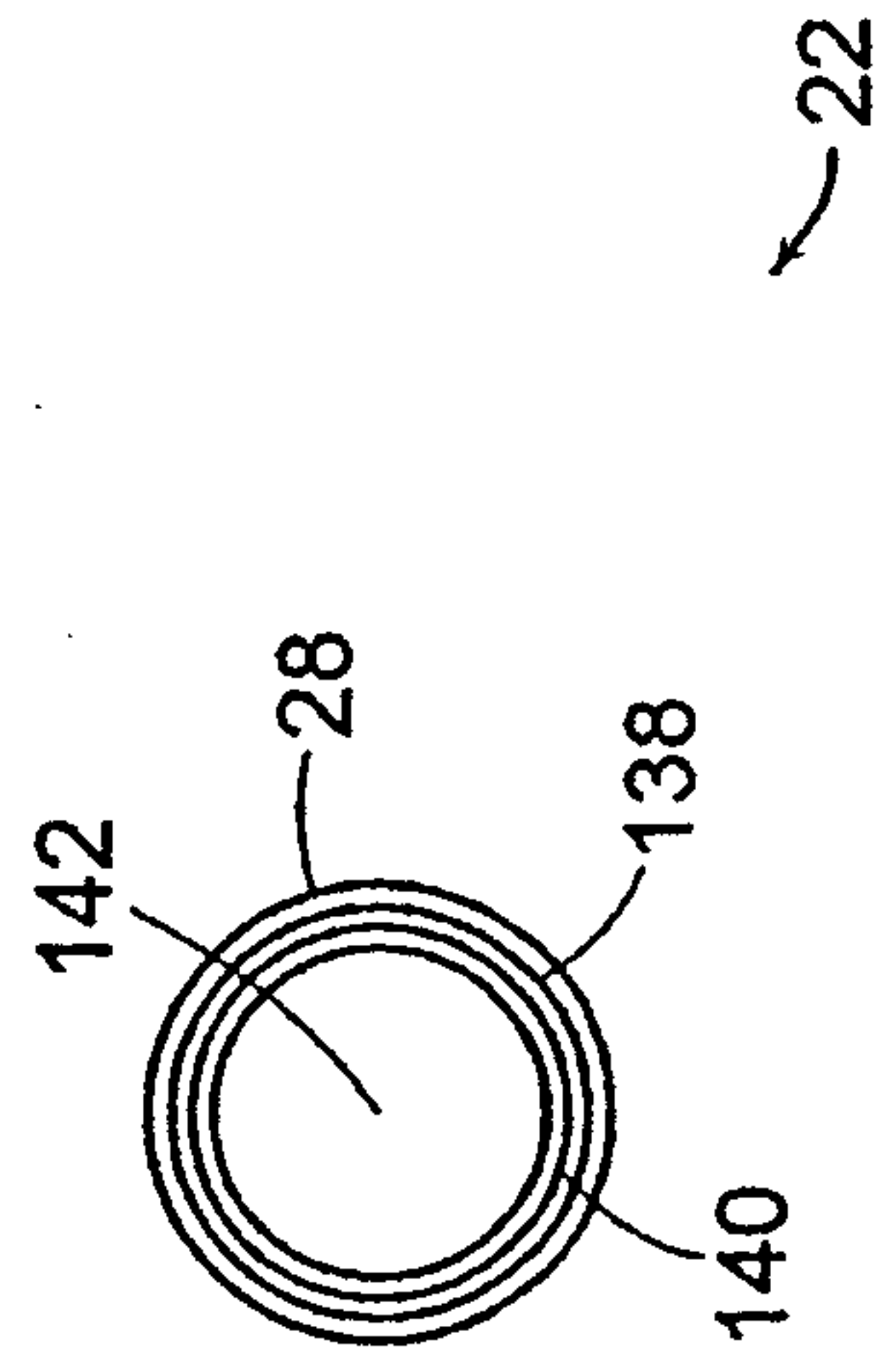

FIG. 10B

10/20

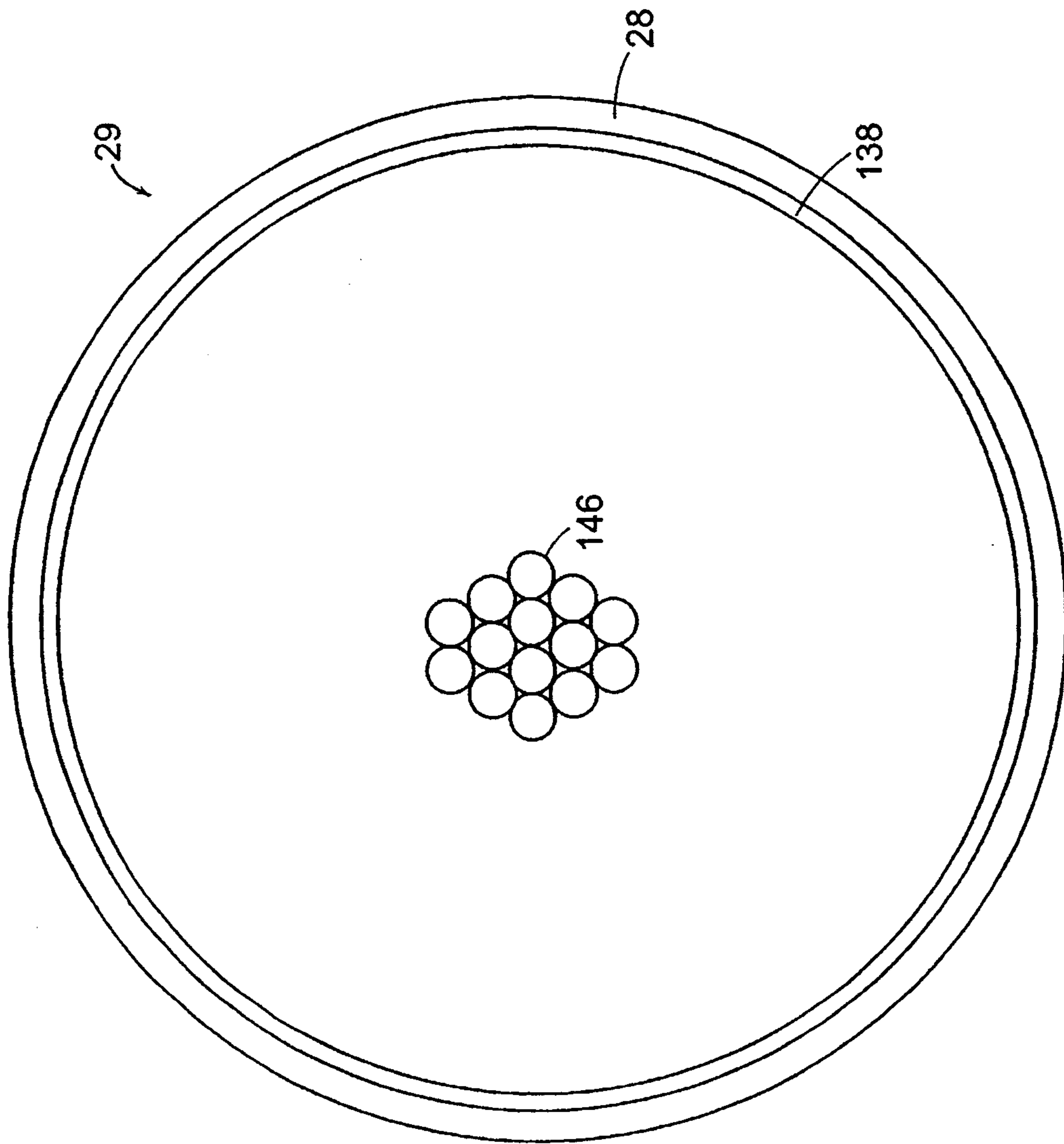

FIG. 11

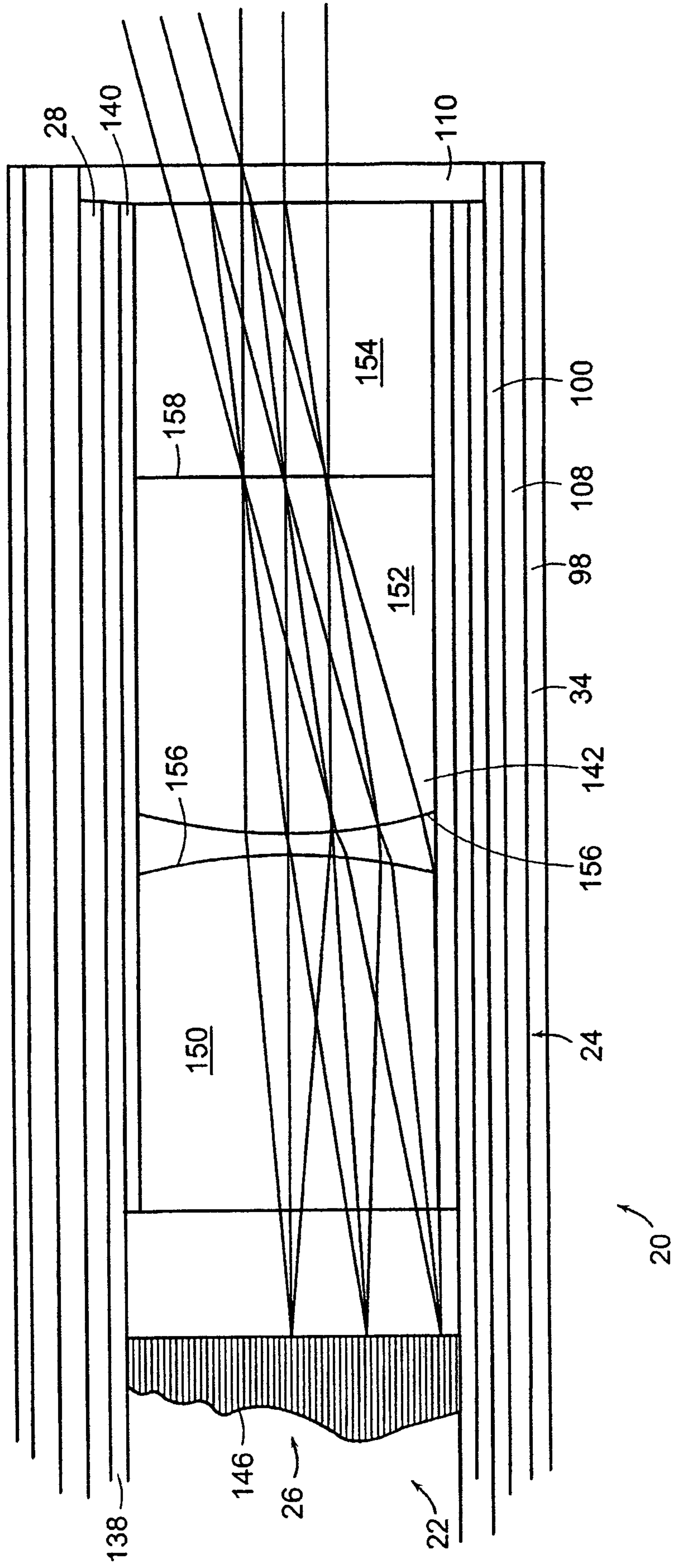

FIG. 12

12/20

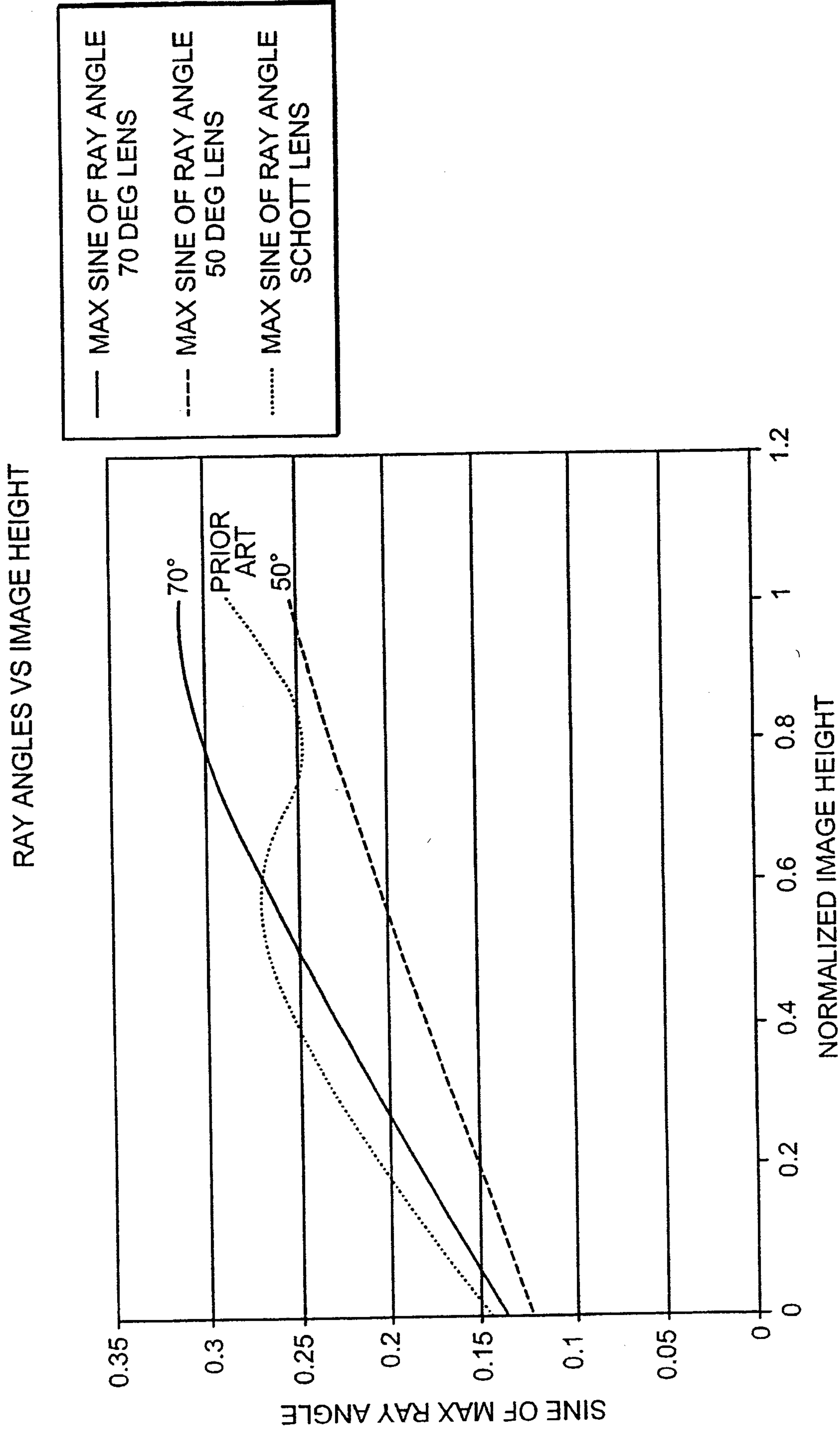

FIG. 13

13/20

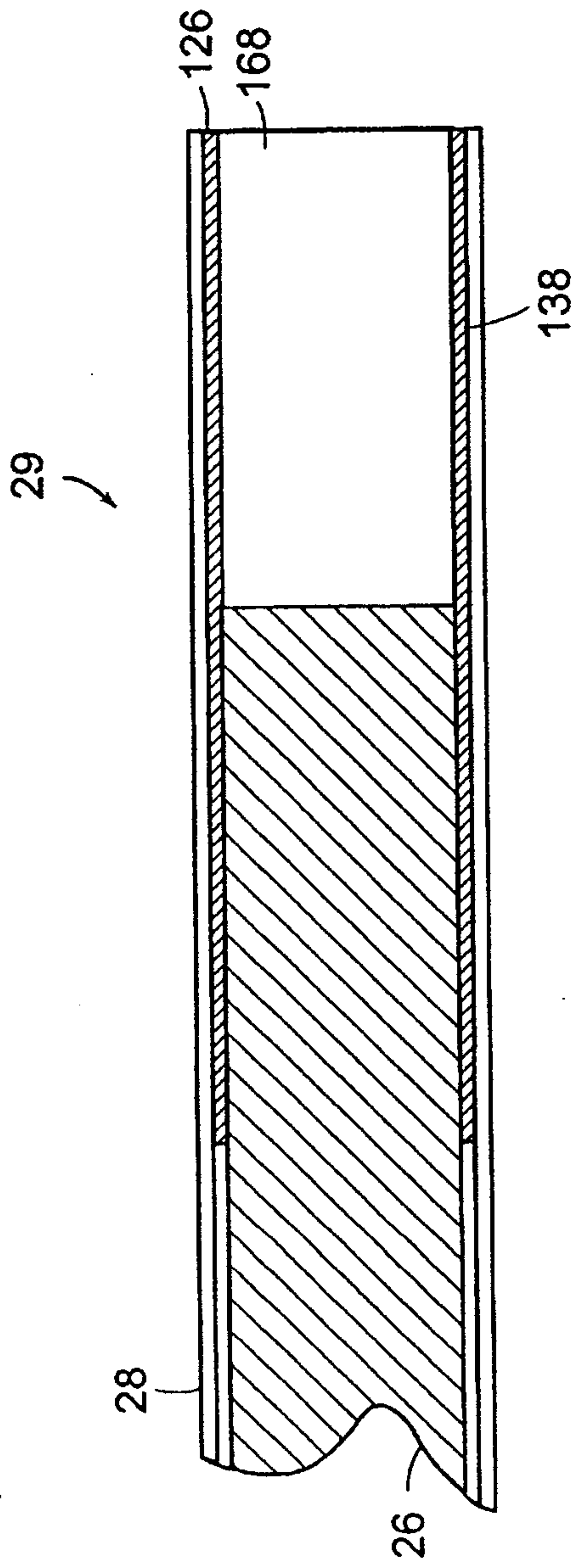

FIG. 14

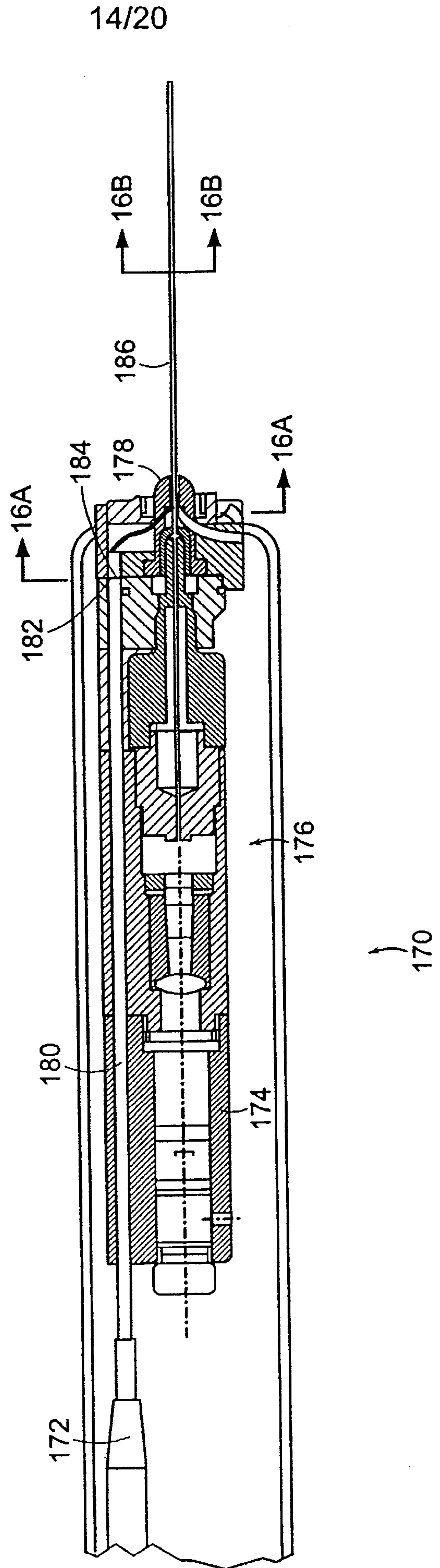

FIG. 15

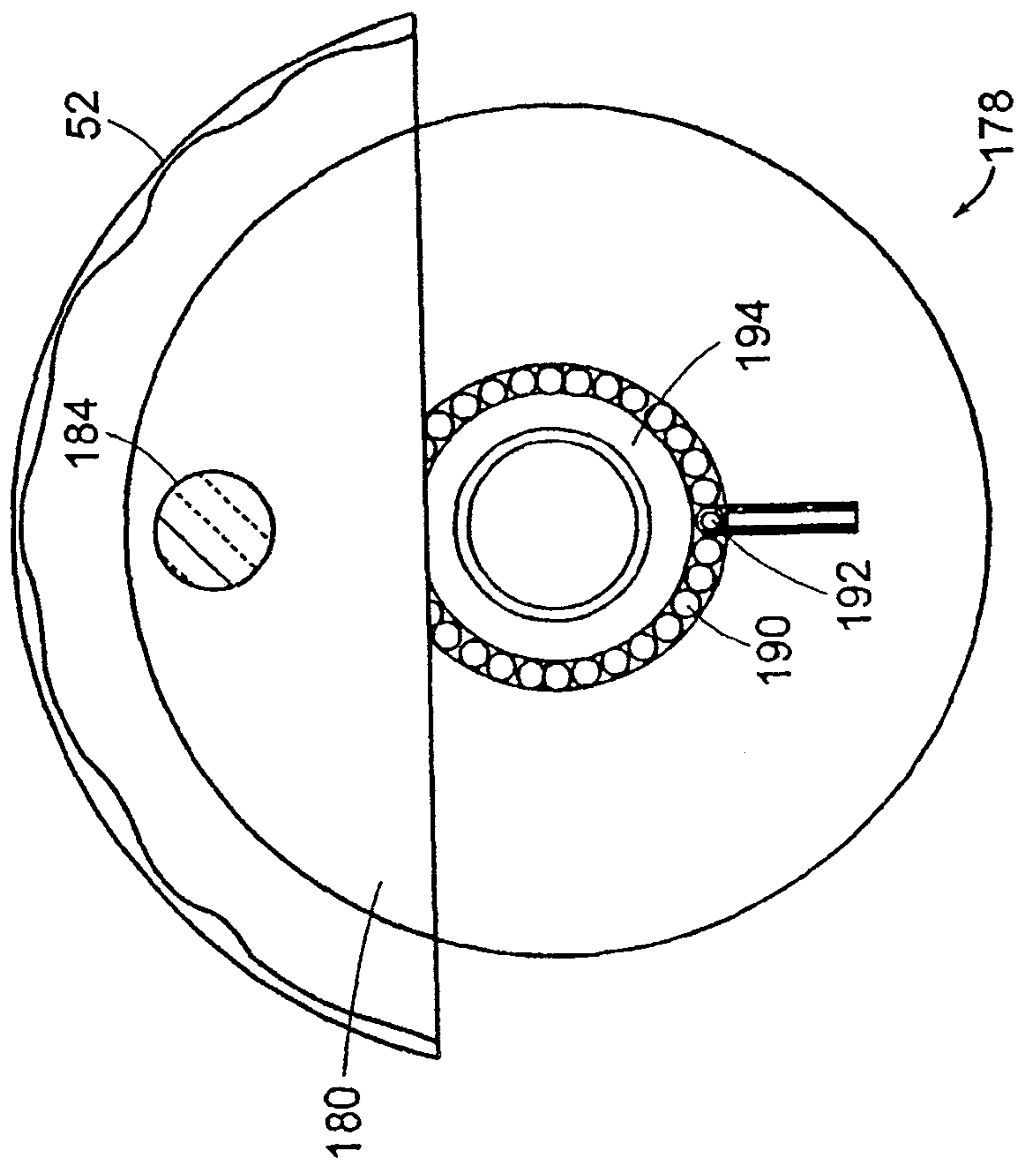

FIG. 16A

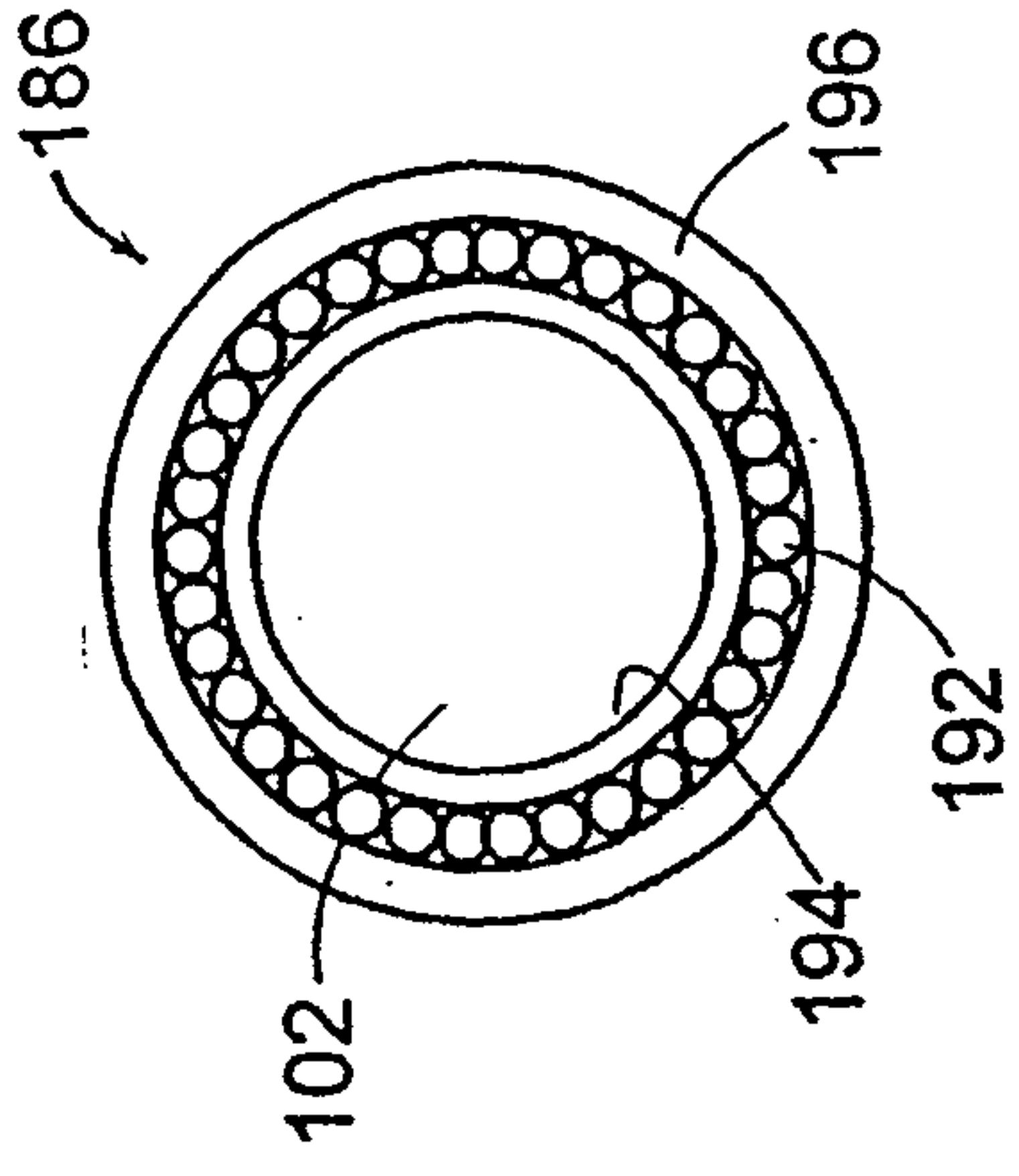

FIG. 16B

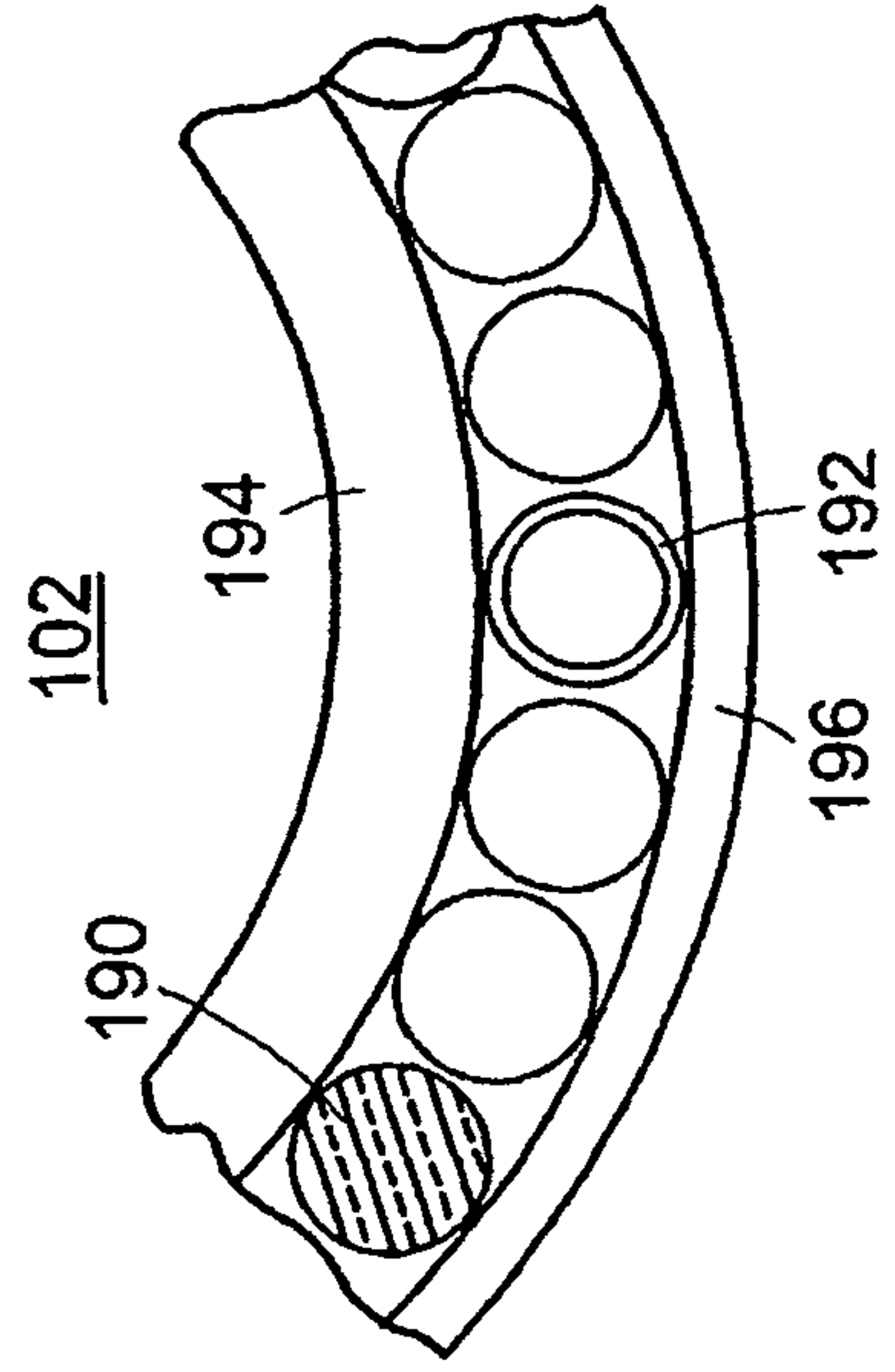

FIG. 16C

16/20

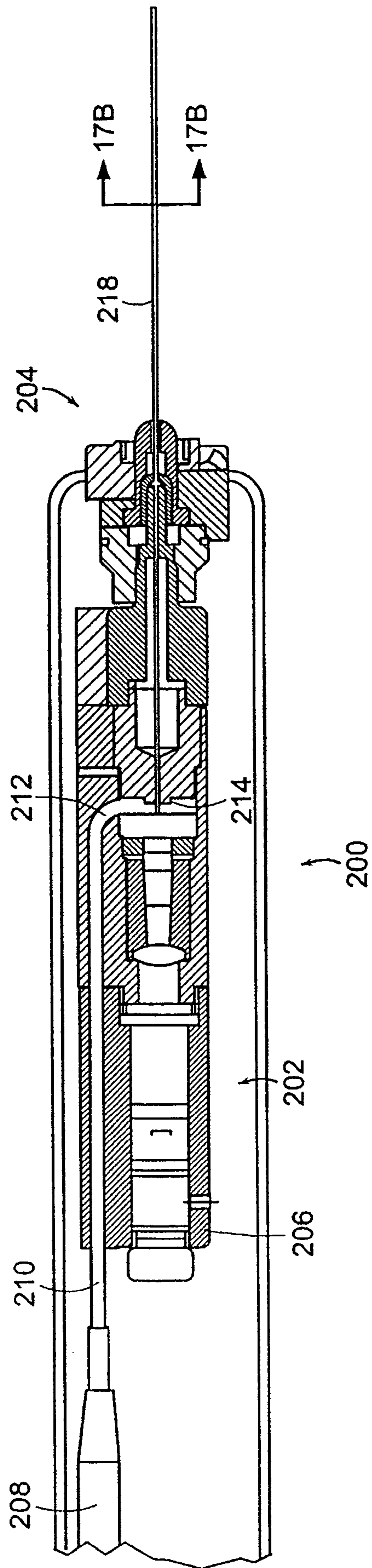

FIG. 17A

17/20

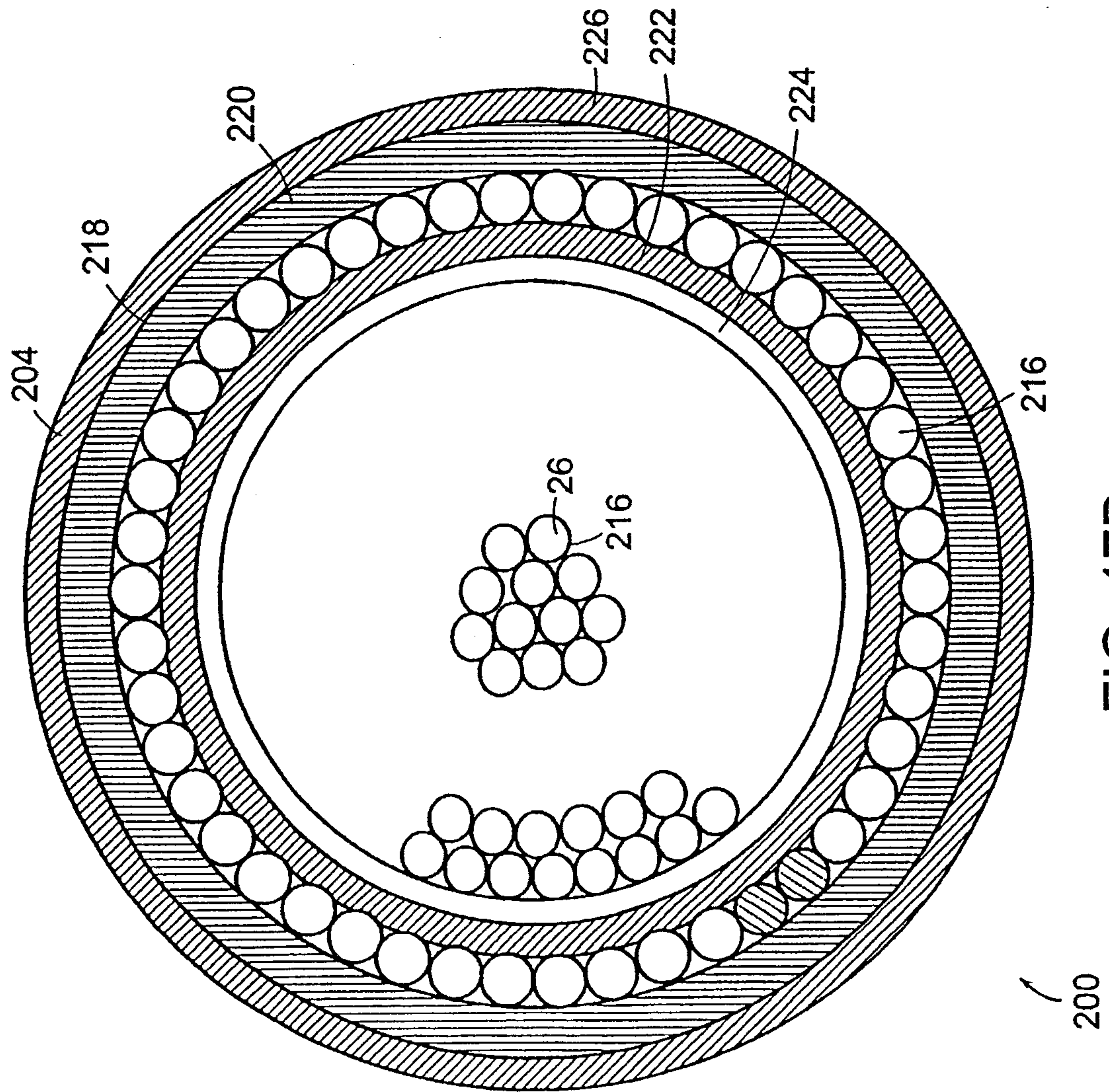
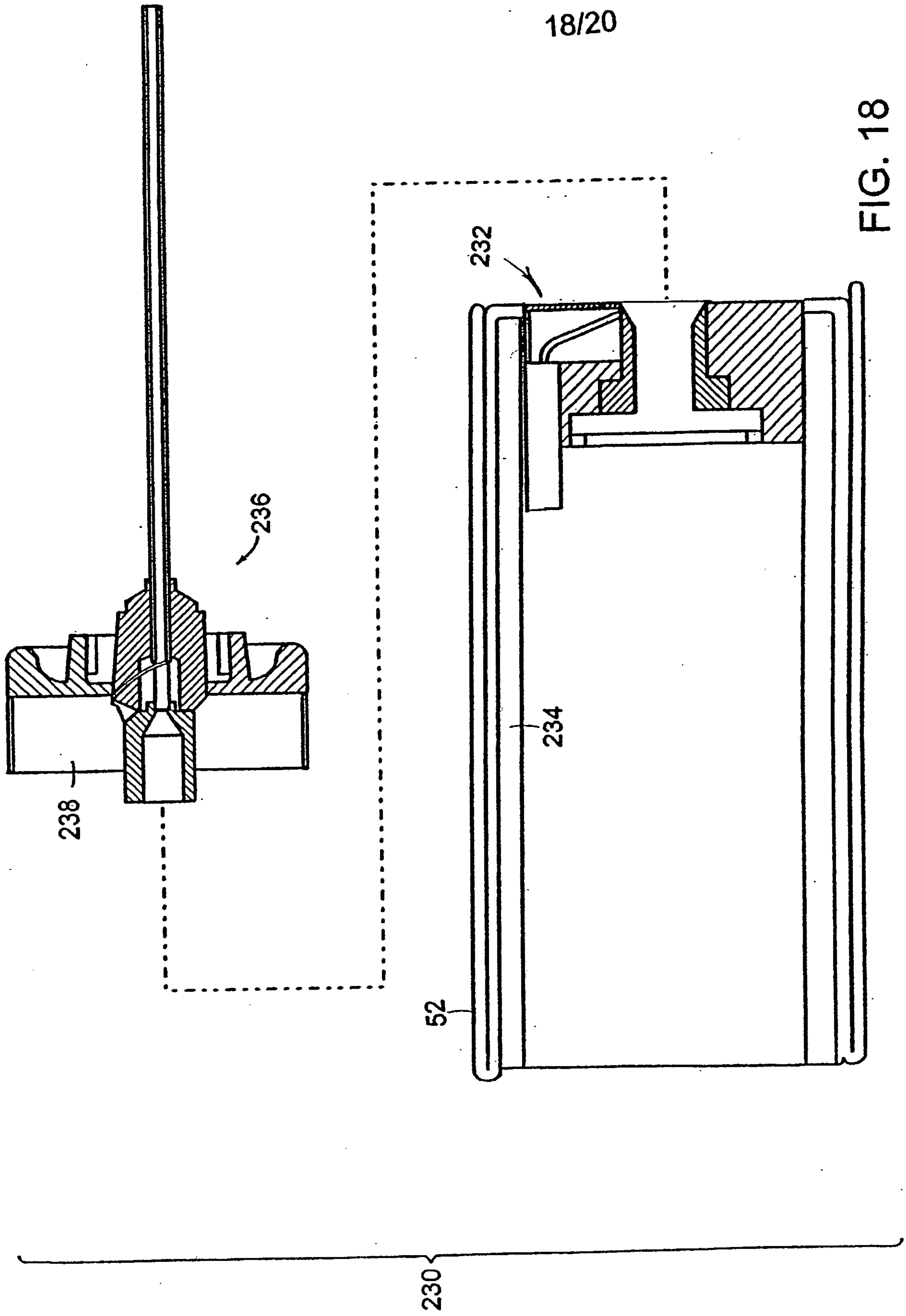

FIG. 17B



19/20

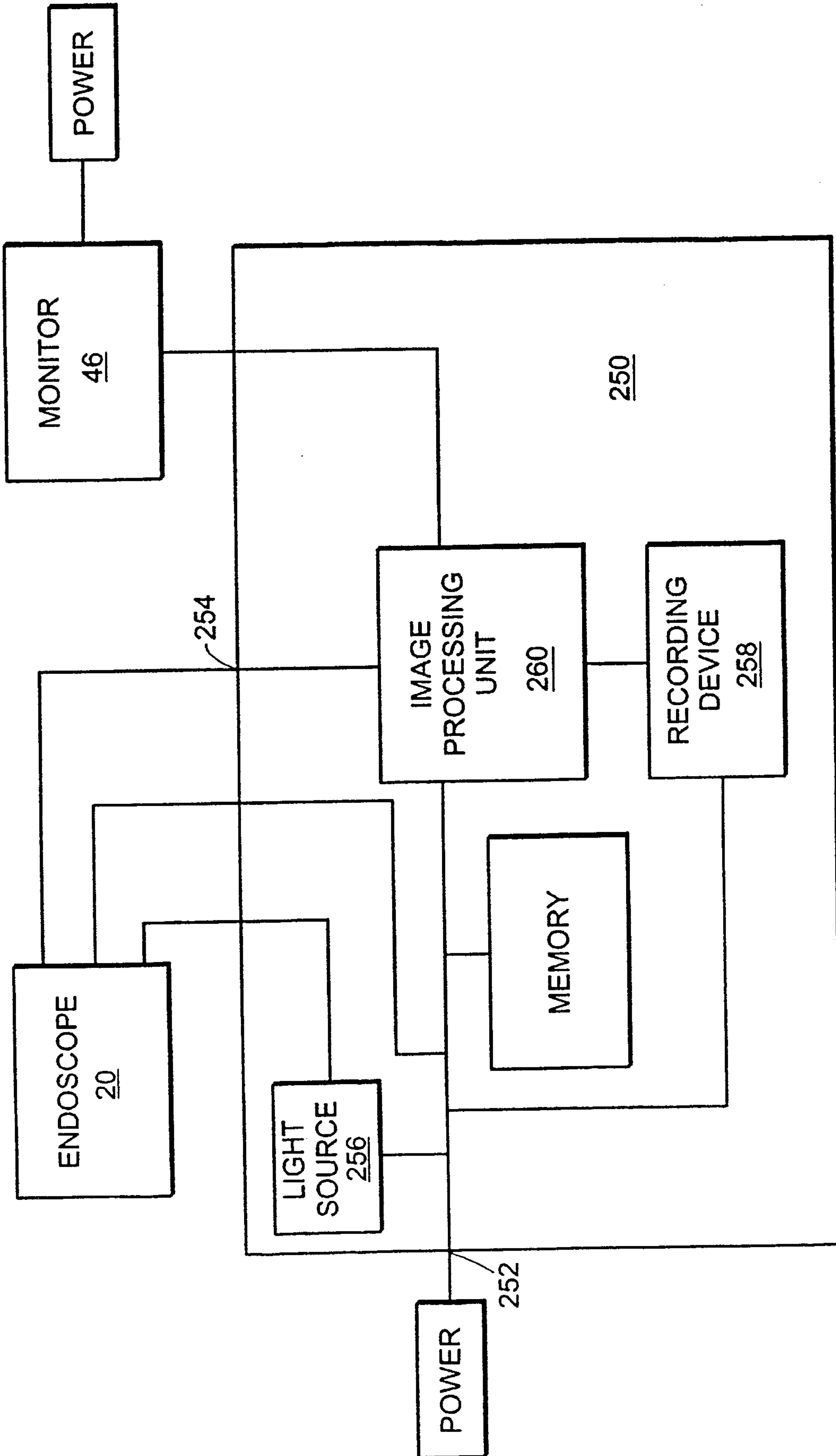

FIG. 19

20/20

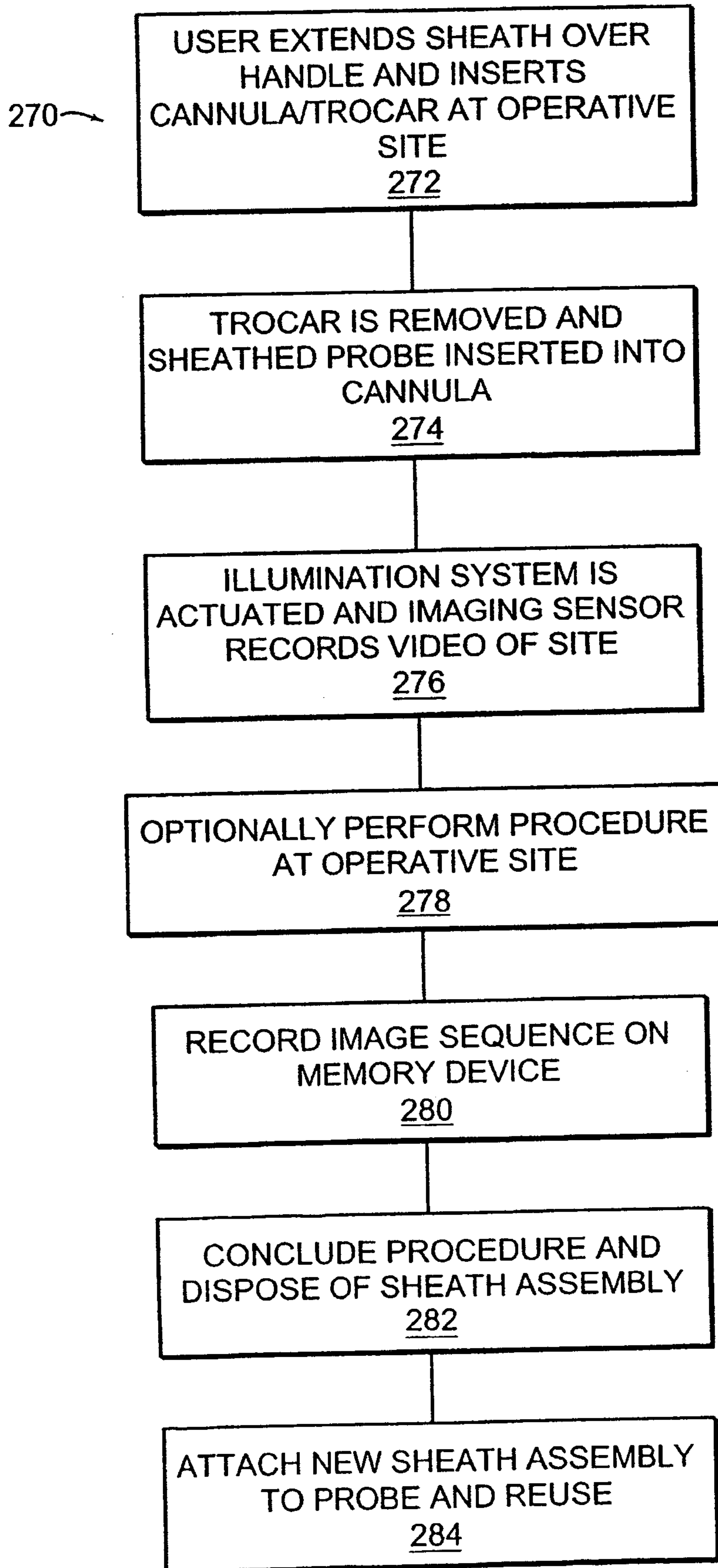

FIG. 20

