

Aug. 16, 1966

G. SCHWARTZMAN
SPIN WELDED APPLICATOR

3,266,079

Filed April 2, 1964

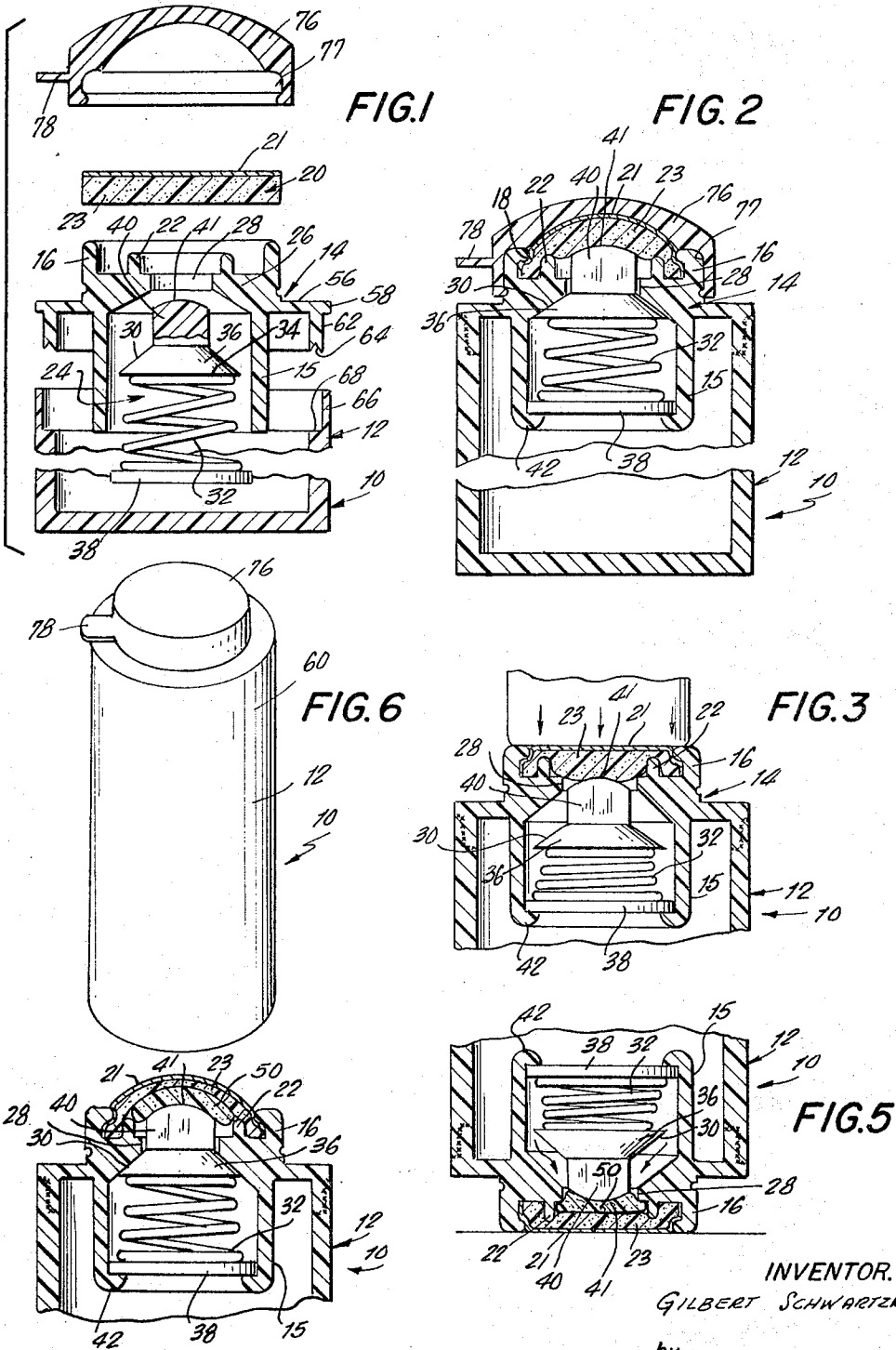

INVENTOR.
GILBERT SCHWARTZMAN

by
Bruskin & Goldfarb
ATTORNEYS

1

2

3,266,079

SPIN WELDED APPLICATOR

Gilbert Schwartzman, 20 Wilmot Circle, Scarsdale, N.Y.
Filed Apr. 2, 1964, Ser. No. 356,916

1 Claim. (Cl. 15-569)

This invention relates to an applicator for use in applying shoe polish, cosmetics or medications and more particularly to a spin welded assembly including a dauber and container.

An object of this invention resides in the provision of means for facilitating the application of shoe polish or the like.

Another object of this invention resides in the provision of a novel dauber having valve means which is automatically actuated and adapted to control the flow of shoe polish from a dauber for obtaining an even flow of shoe polish onto a shoe, the dauber being spin welded to a container so as to form a unitary assembly.

A further object of this invention is to provide for better control of fluid flow of material being applied while also providing for a leakproof, spillproof package for the material to be applied, which eliminates the necessity for a container having an elongated neck thereby saving on material costs.

It is highly desirable that packages for shoe polish, various medications, and cosmetics be spillproof and leakproof because of the permanent stains that can result when the material in the package is released due to accident or inadvertence. Accordingly, it is an additional object of this invention to provide a spillproof, substantially shatterproof, leakproof unitary applicator, which can be easily assembled and filled.

In the past daubers have been constructed which are provided with projecting portions which are inserted in the necks of containers. These projecting portions have all been of reduced cross sectional dimensions to allow for proper construction and operation of the valve assemblies of these daubers. The containers used with such projecting portions have necessarily been constructed with elongated necks. Modern packaging techniques and styles are eliminating such containers with elongated necks in an attempt to render packages more compact, streamlined and eye-appealing. Further, in modern packaging there is an ever-increasing use of various synthetic plastics such as polyethylene and polyurethane for the production of substantially unbreakable containers.

Accordingly, it is another object of this invention to provide an applicator having a dauber with a compressed body disposed between the dauber cover and the valve member, which compressed body will permit fluid flow to other parts of the cover and into the space between the cover and the retainer ring, and which assembly conveniently permits the filling of the applicator by means of a needle insertable through the cover and compressed body and past the valve member.

Still another object and feature of this invention resides in the provision of an applicator which is inexpensive to manufacture, simple to fill with fluid of various viscosities in an effective manner so that the dauber is especially adapted for use in applying shoe polish, medications, cosmetics, oils, polishes and the like, and which applicator may be made in any convenient size as desired.

These, together with the various ancillary objects and features of the invention, which will become apparent as the following description proceeds, are attained by this dauber, a preferred embodiment of which has been illustrated in the accompanying drawings, by way of example only, wherein:

FIG. 1 is an exploded vertical sectional view illustrating component elements of the applicator;

FIG. 2 is a cross-sectional view illustrating the applicator in an assembled state;

FIG. 3 is a cross-sectional view similar to that of FIG. 2, but illustrating the applicator with the valve assembly in an open position;

FIG. 4 is a sectional detail view of another embodiment of the applicator including a compressed body forming a part of the dauber, with the valve assembly in a closed position;

FIG. 5 is a sectional view of the embodiment of FIG. 4, but illustrating the dauber in use for application of shoe polish or the like; and

FIG. 6 is a perspective view of the applicator.

With continuing reference to the accompanying drawings, wherein like reference numerals designate similar parts throughout the various views, reference numeral 10 is used to generally designate the applicator comprising the present invention. This applicator includes two main parts, a container 12 formed of a suitable plastic material such as polyethylene, polyurethane or the like, and a dauber assembly 14 adapted to be permanently fused to the container 12. The dauber assembly 14 includes a valve housing 15 having a flange 16 provided with a swaged lip 18 for retaining a disc 20 in position between the lip 18 and rib 22 of circular configuration.

The disc 20 is constructed of two layers, the upper layer 21 of which is formed of nylon knitted brushed fabric so as to achieve a felt-like applicator surface and appearance, while having the chemical inertness and strength of the nylon. Laminated and bonded to the nylon knitted brush fabric is the lower layer 23 of coarse polyurethane foam.

The housing 14 is provided with a tapered web 26 which has an arcuate opening 28 therein which is of approximately one-half of the diameter of the web 26. Co-operating with the arcuate tapered web 26, which serves as a valve seat, is the conical surface 30 of a valve member, forming part of a valve assembly generally indicated at 24. The valve assembly 24 includes a spring 32 formed in helical coils, the portion of smaller diameter being secured or integrally formed at 34 with the truncated conically-shaped valve head 36. The lower end 38 of the spring 32 is in the form of a ring and is held in place in the housing 15 by the swaged end 42 of the housing 15. The swaged end 42 thus retains the valve assembly 24 within the housing 15 with the spring 32 in a continuously stressed condition under compression so that the cylindrical portion 40 of the valve head 36 is continuously urged into and through the opening 28 for the purpose of closing the opening 28 and preventing fluid flow from the container 12 into the space between the web 26 of the housing 15 and the cover 20. The cylindrical portion 40 is provided with a rounded end surface 41.

In the form of the invention as shown in FIGS. 4 and 5 there is disposed between the valve head 36 and the cover 20 a cylindrical body 50 of coarse polyurethane foam which is continuously compressed and serves to bulge the cover 20 in a convex manner. The valve head 36 is continuously biased into engagement with the compressed body 50 further squeezing the body. However, as shown in FIG. 5, when the applicator is used for applying shoe polish or other fluids, the cover 20 is depressed, forcing the compressed body 50 slightly into the opening 28 and opening the valve by depressing the valve head to permit passage of fluid in a direction indicated by arrows A, FIG. 5, whereby fluid will not only saturate the polyurethane foam body 50, but will saturate the cover 20. Since the inner or lower layer 22 is of a polyurethane foam, it will absorb and retain sufficient fluid so that the dauber will be able to provide a uniform coating of shoe polish on the surface being treated.

3

One of the advantages of the compressed body 50 is that it provides in continuous contact with the cover a source of fluid and will absorb all the excess fluid in the space 52 which remains there after the valve assembly 24 has moved to its "valve closed" position, thereby preventing leaking or spilling of fluid out of and beyond the cover 20.

Depending mainly upon the size of the compressed body 50, the cover 20 may be stretched to assume various shapes. It has been found that for application of shoe polish, a hemispherical shape is preferred because otherwise hard to reach places can be easily given an adequate coating of shoe polish.

Integrally formed and molded with the housing 15 is a flange 56 which extends outwardly normal to the housing 15 and its outermost edge 58 lies flush with the outer surface of the container 12. Downwardly extending from the flange is a lip 62 which has a V-shaped groove 64 in the lower edge thereof. The groove 64 facilitates better integral bonding during spin welding of the container 12 with the lip 62.

The container 12 is provided with an upper portion 66 of reduced wall thickness adapted to lie against the lip 62 with the grooved lower edge of the lip abutting against the interior shoulder 68. The container 12 and dauber assembly 14 are then spin welded together to fuse the container 12 to the dauber assembly 14 to form the unitary integral applicator.

In order to fill the applicator, a needle on the order of a hypodermic needle is inserted through the cover 20 and the valve head 36 is depressed allowing the container to be filled.

The embodiment shown in FIGS. 4 and 5 has an unusual and unexpected advantage. When filling the container 12, the needle will pierce the cover 21 and the body 50. However, after filling, the body 50 will move slightly with respect to the cover 20 upon release of the valve head 36 causing a labyrinth blocking of the opening caused by the needle, exceedingly small as it is thereby preventing leakage by any type of fluid used.

The container 12 may be of any convenient size and shape. A cap 76 is provided and may be of a snap-fit type arranged with groove 77 therein and to snap over the swaged end 18. A detent 78 may be provided to facilitate removal of the cap 76.

A latitude of modification, change and substitution is intended in the foregoing disclosure, and in some in-

4

stances some features of the invention will be employed without a corresponding use of other features. Accordingly, it is appropriate that the appended claim be construed broadly and in a manner consistent with the spirit and scope of the invention herein.

I claim:

An applicator comprising a housing, a first flange having a swaged lip integral with said housing, said housing having a web extending transversely thereof, said web having an opening therein forming a valve seat, a rib on said web surrounding said opening, a cover secured to said housing between said lip and said rib, a spring-pressed valve member provided with a valve head having a rounded end surface, said valve member being secured in said housing and movable with respect to said valve seat to control fluid flow through said opening, a resilient cylindrical porous body disposed in the space between said cover and said web, said body when not compressed being of such dimensions that said body is thicker than the space between said cover and said housing, said body having a diameter substantially greater than said opening and no greater than said rib, said body being engaged by said valve head so as to be continuously under compression with said body being laterally movable over said rounded end surface, said applicator being fillable through said cover and said body so that after filling lateral movement of said body enable said body to form a labyrinth stop, a second flange integral with and extending outwardly of said housing normal thereto, a downwardly extending lip integral with said second flange extending downwardly from said second flange inwardly of the peripheral edge thereof, and a container having an upper portion of reduced wall thickness, said upper portion surrounding and abutting said downwardly extending lip and being fused thereto.

References Cited by the Examiner

UNITED STATES PATENTS

40	3,095,598	7/1963	Gonnella et al. -----	15-571
	3,129,452	4/1964	Schwartzman -----	15-566
	3,133,307	5/1964	Steinberg et al. -----	15-563
	3,161,904	12/1964	Goldich -----	15-563 XR

45 CHARLES A. WILLMUTH, *Primary Examiner.*

S. E. BECK, PHILIP R. ARVIDSON,

Assistant Examiners.