

(21) Application No: **0512398.9**
(22) Date of Filing: **13.08.2002**
Date Lodged: **17.06.2005**
(30) Priority Data:
(31) **60318021** (32) **07.09.2001** (33) **US**
(62) Divided from Application No **0406258.4** under Section 15(4) of the Patents Act 1977

(51) INT CL⁷:
E21B 43/10
(52) UK CL (Edition X):
E1F FLA
(56) Documents Cited:
WO 2003/023178 A **WO 2003/016669 A**
WO 2002/059456 A **US 20050022986 A1**
(58) Field of Search:
UK CL (Edition X) **E1F**
INT CL⁷ **E21B**
Other: **WPI, EPODOC**

(71) Applicant(s):
Enventure Global Technology
(Incorporated in USA - Delaware)
16200-A Park Row, Houston, Texas 77084,
United States of America

(continued on next page)

(54) Abstract Title: **Plastically deforming and radially expanding an expandable tubular member**

(57) Apparatus 300 is inserted into a tubular member 120 which causes an upper end 120b of the tubular member to impact collets and compress springs so as to apply axial biasing forces to a split ring collar 330 and expansion cone segments 325. The segments 325 are thus maintained in a position that is less than the inside diameter of the tubular member 120. Also an axial biasing force is applied to a tubular sleeve to prevent it from covering a radial passage 315d in a tubular support member 315. Thus, fluids within the interior 315a of the tubular support member 315 may pass through the radial passage 315d into the annulus between the apparatus 300 and the tubular member 120 thereby preventing over pressurization of the annulus. After positioning the apparatus 300 beyond lower end 120c of the tubular member 120, the apparatus is then repositioned partially back within the tubular member 120. During the re-insertion, the lower end 120c of the tubular member impacts the collets and compresses the springs to seal off the radial passage 315d and drive the expansion cone segments 325 up expansion cone support body 315i. An upward axial force is then applied to the tubular support member 315 to radially expand and plastically deform the tubular member 120.

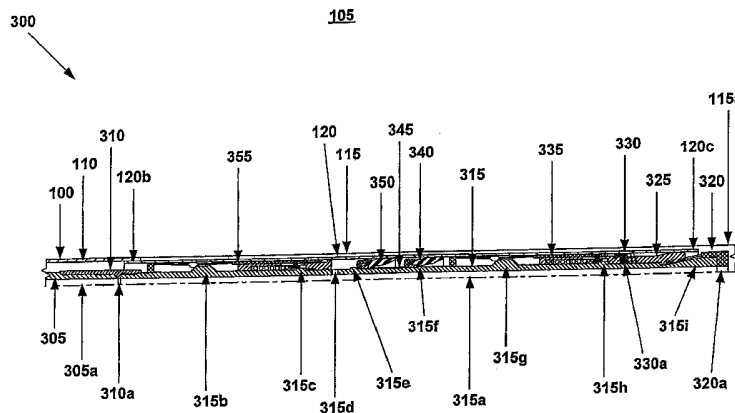

Fig. 4

GB 2412682 A continuation

(72) Inventor(s):

Lev Ring
David Paul Brisco
Kevin Karl Waddell
Robert Lance Cook

(74) Agent and/or Address for Service:

Haseltine Lake & Co
Redcliff Quay, 120 Redcliff Street,
BRISTOL, BS1 6HU, United Kingdom

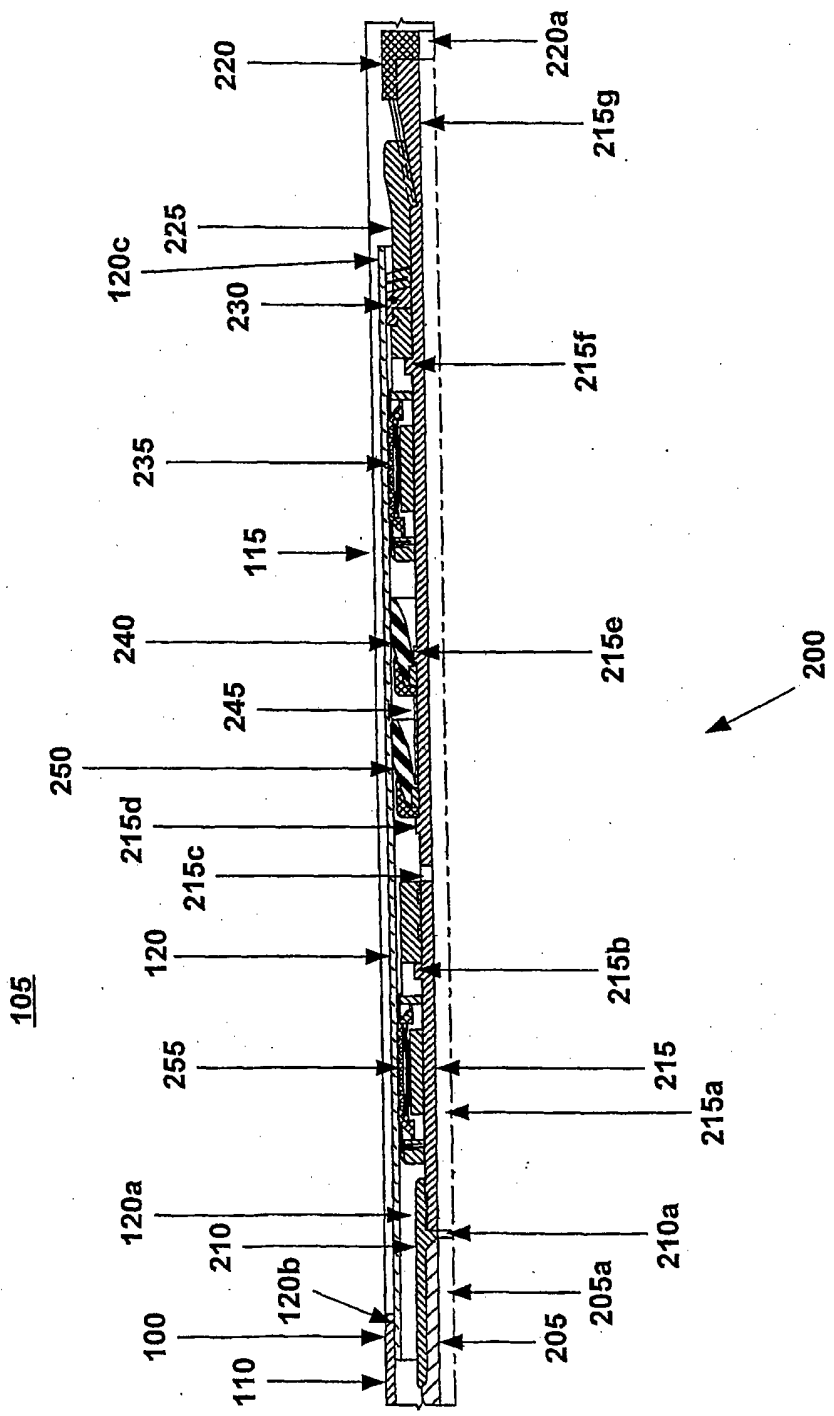

Fig. 1

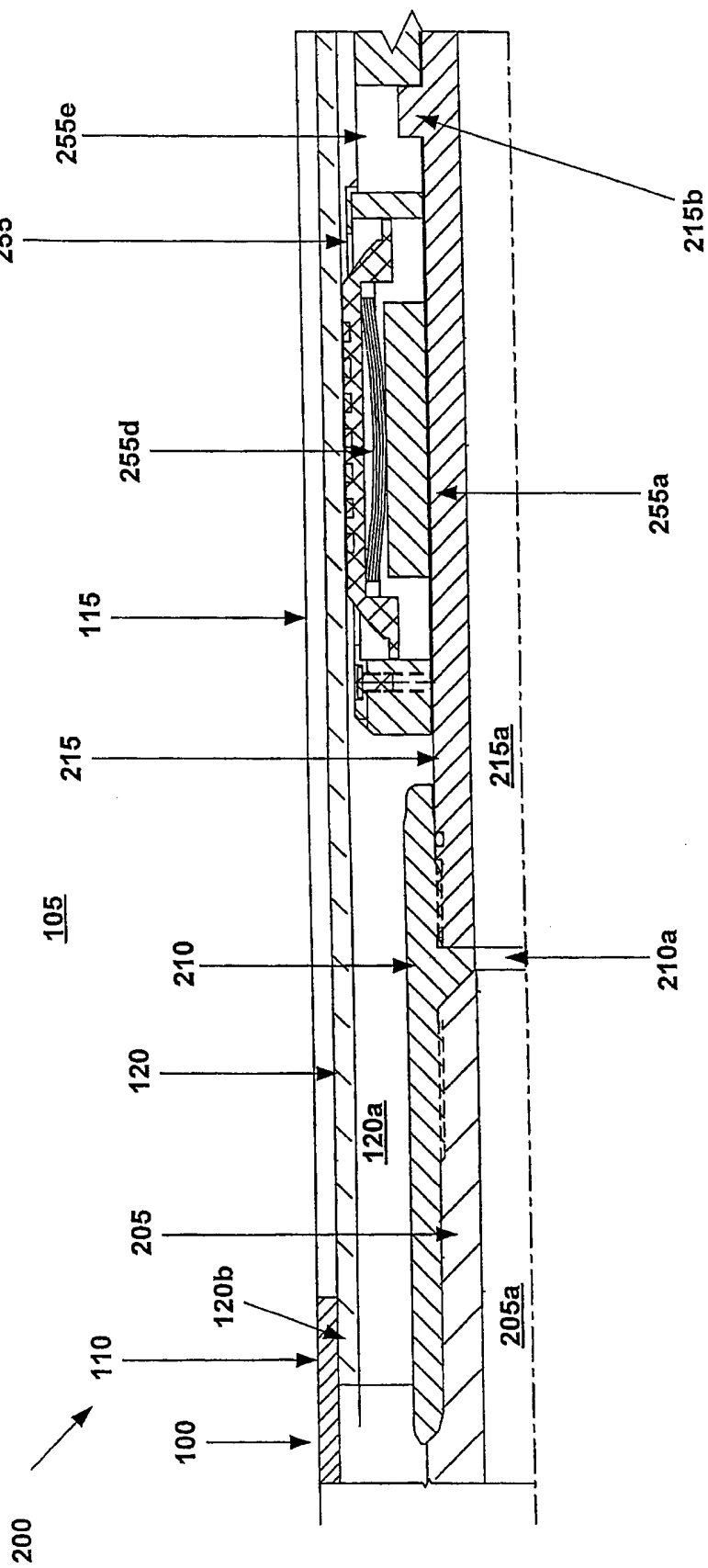

Fig. 1a

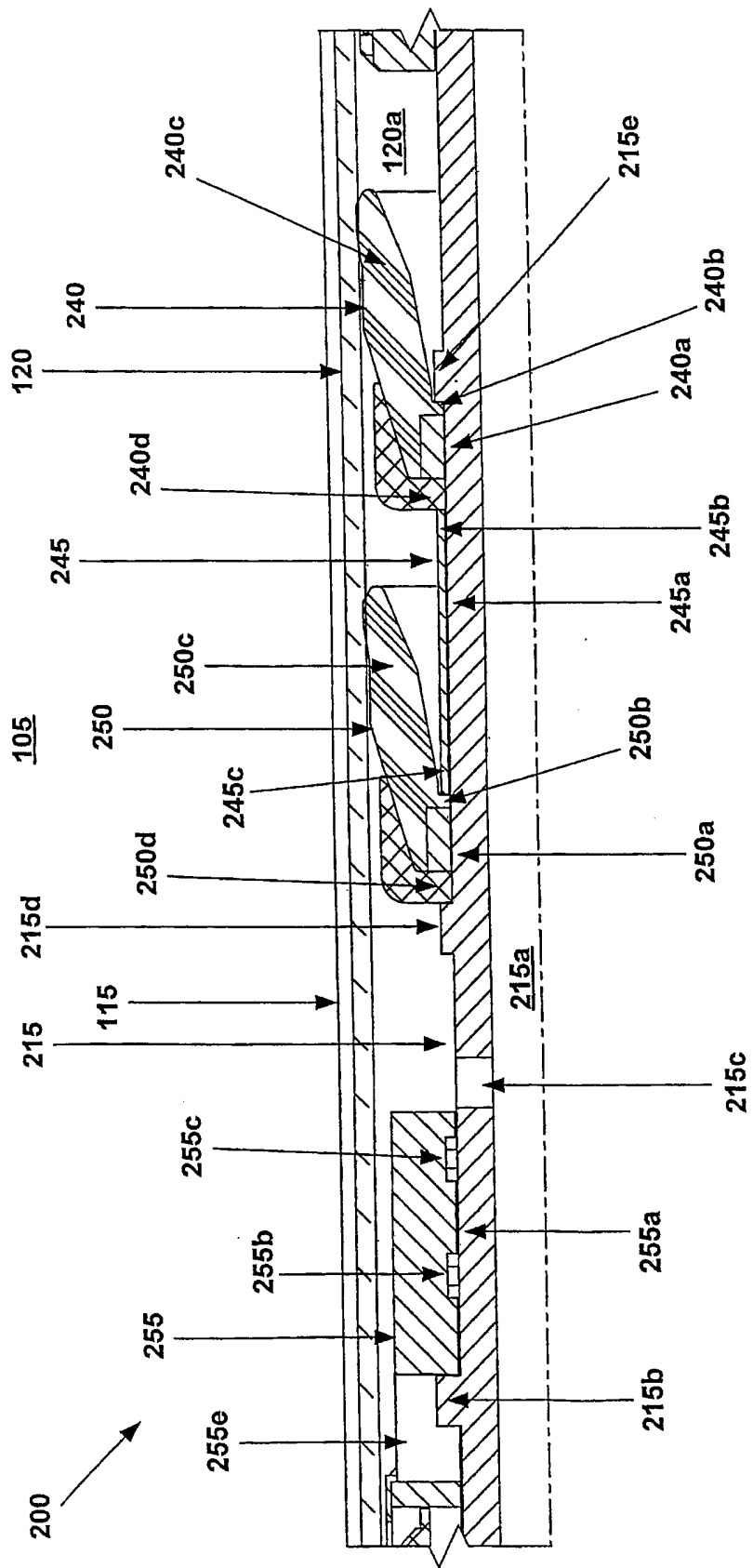

Fig. 1b

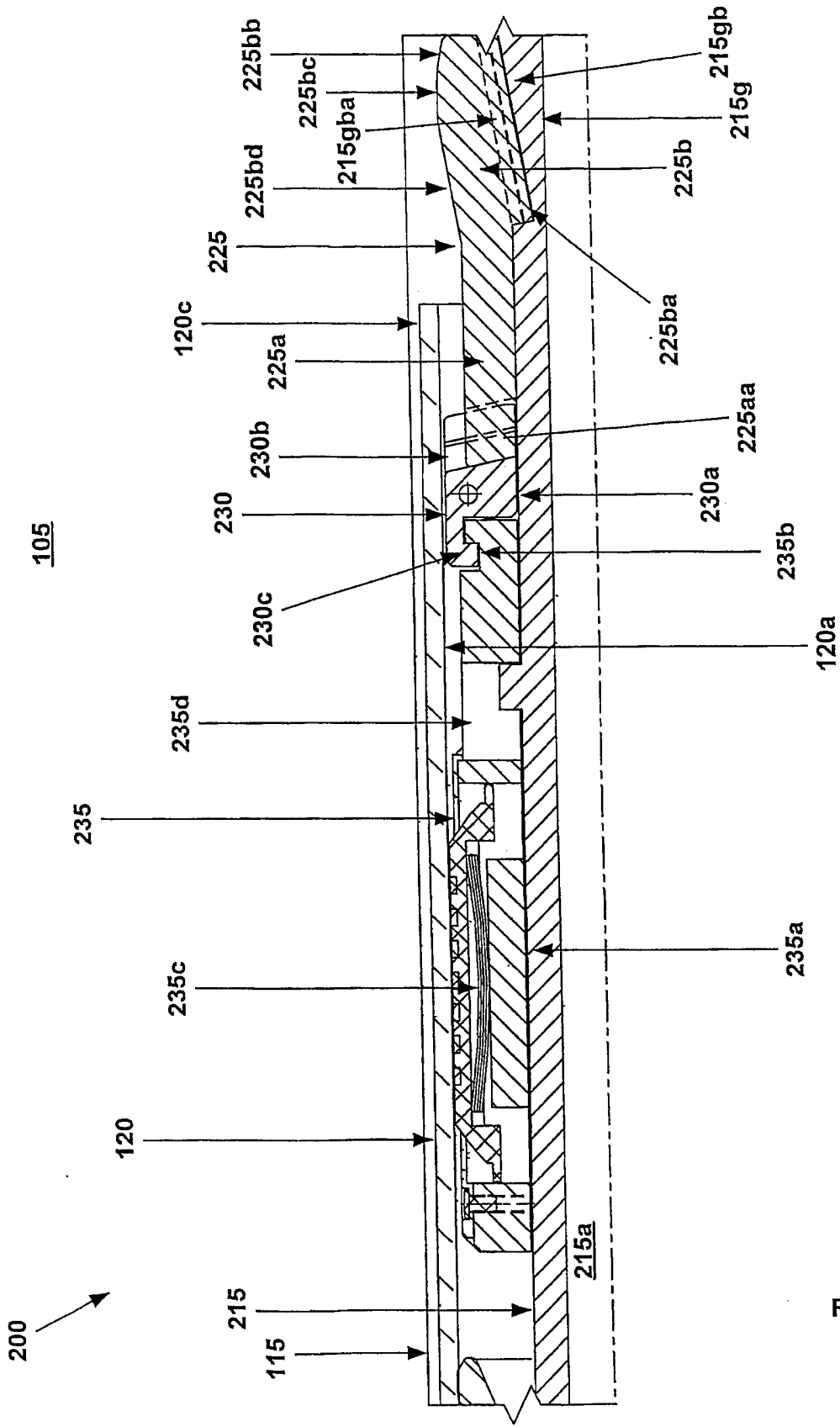

Fig. 1c

105

200 ↗

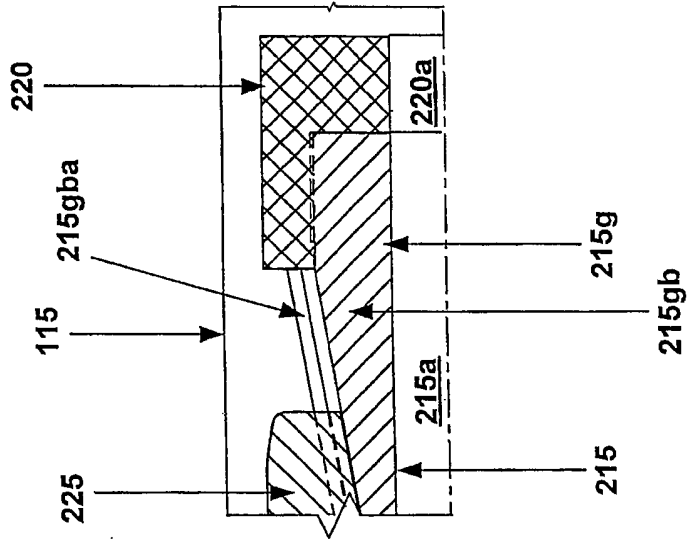

Fig. 1d

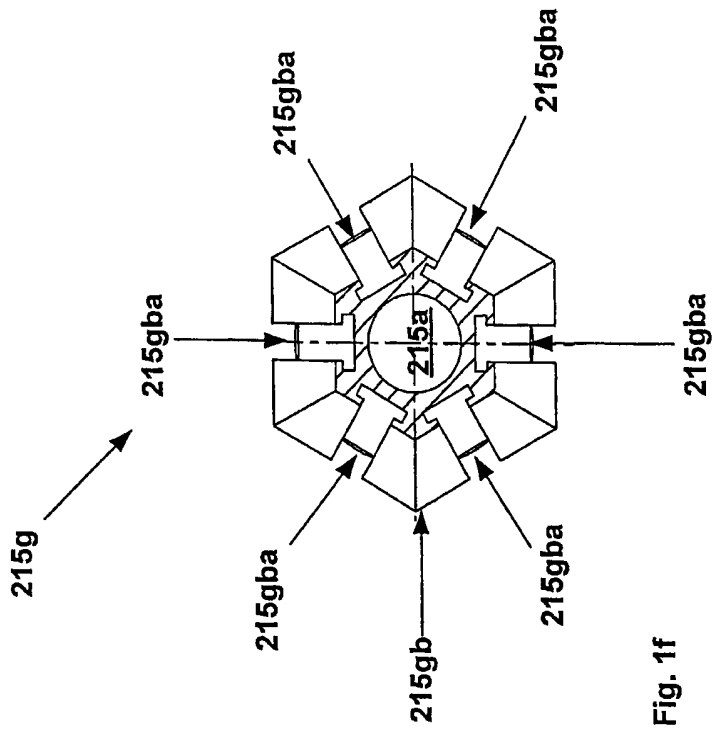

Fig. 1f

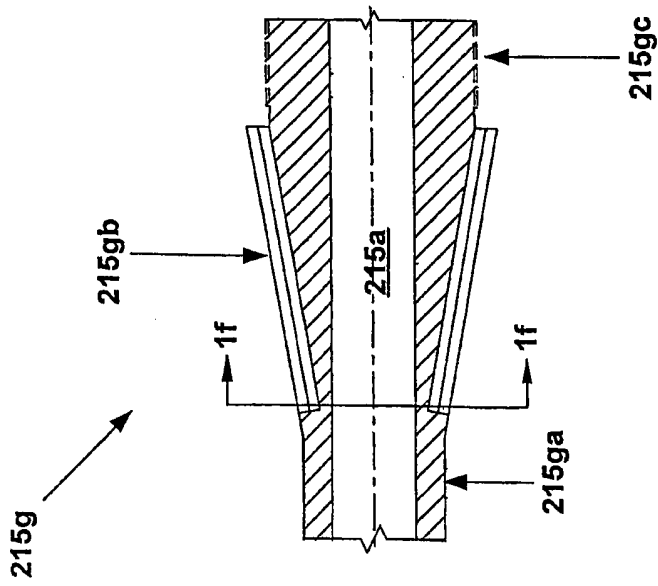

Fig. 1e

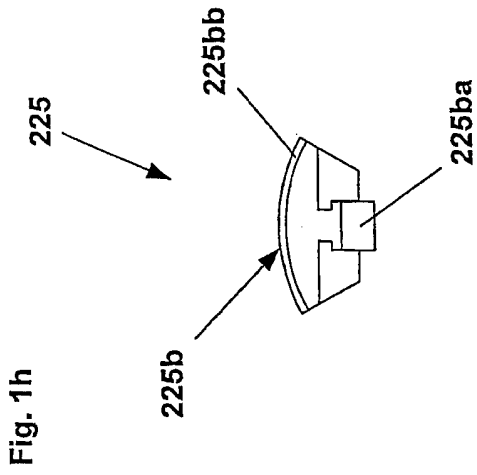

Fig. 1h

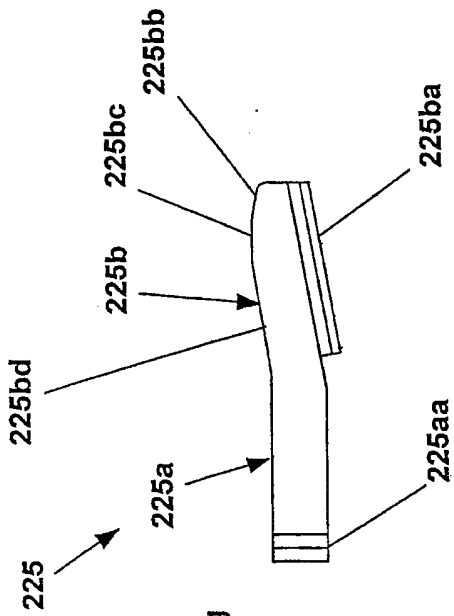

Fig. 1g

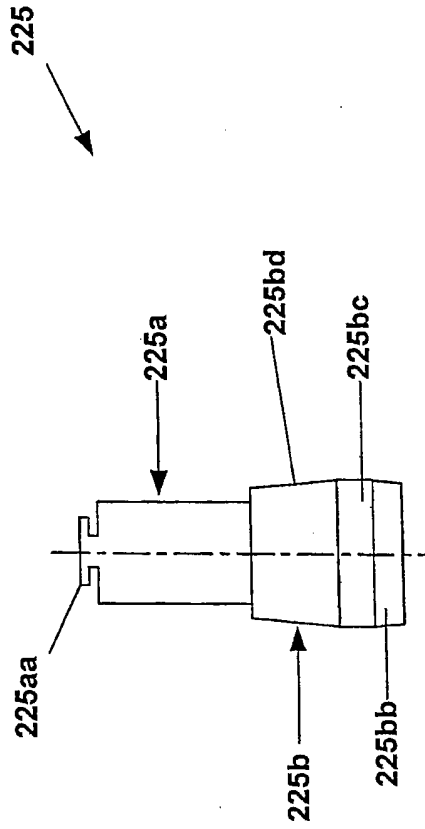

Fig. 1i

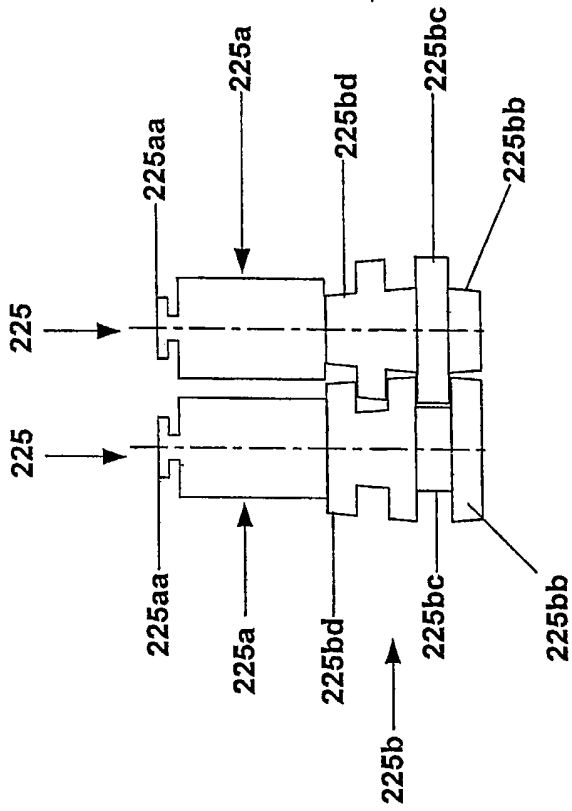

Fig. 1j

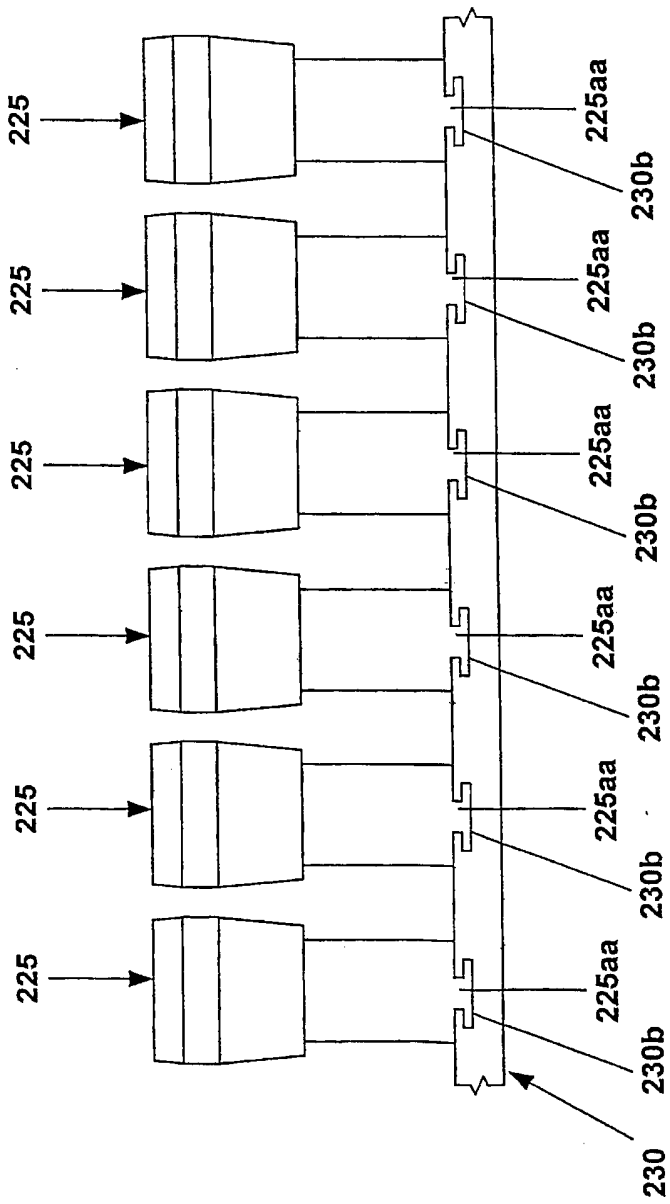

Fig. 1k

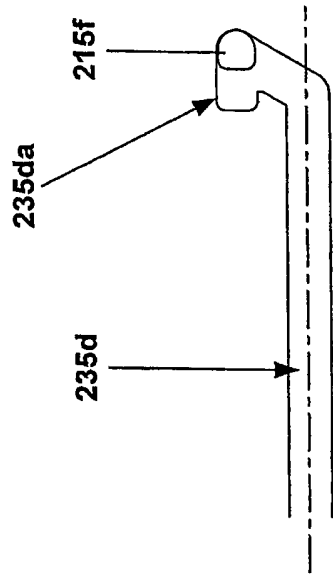

Fig. 1m

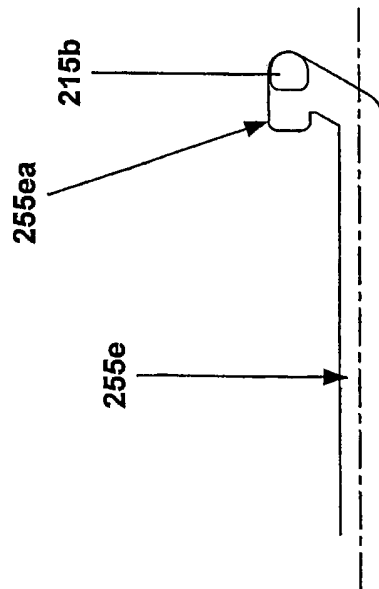

Fig. 1l

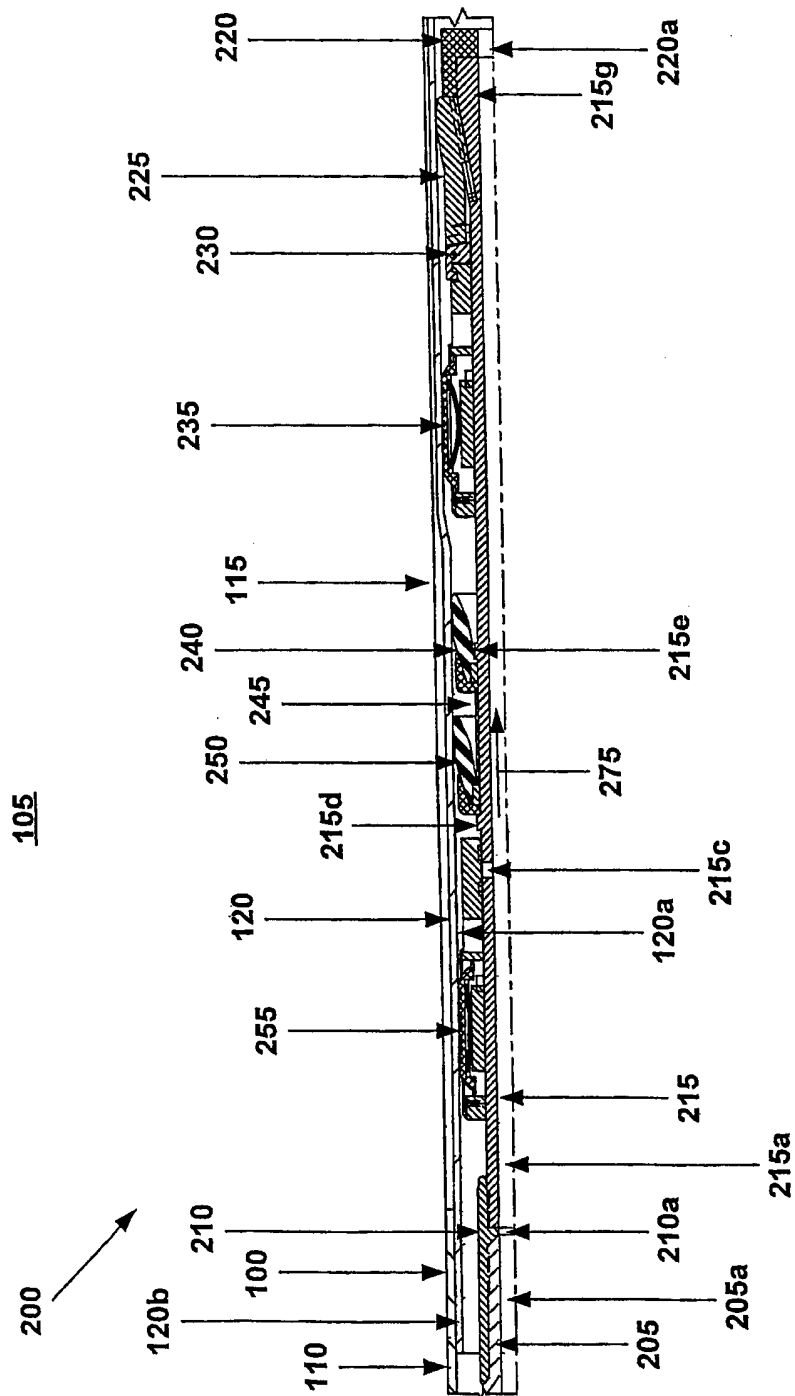

Fig. 2

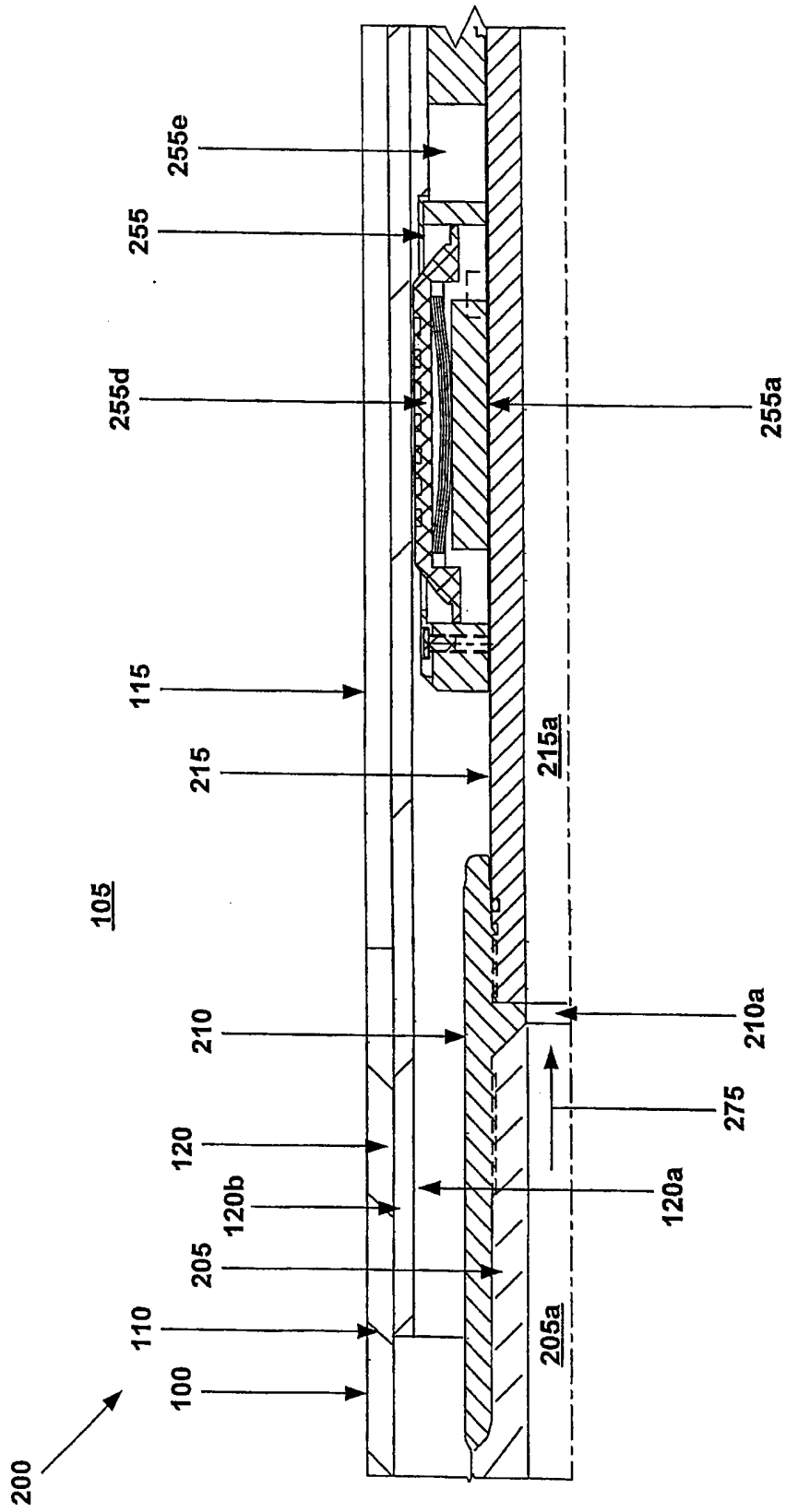

Fig. 2a

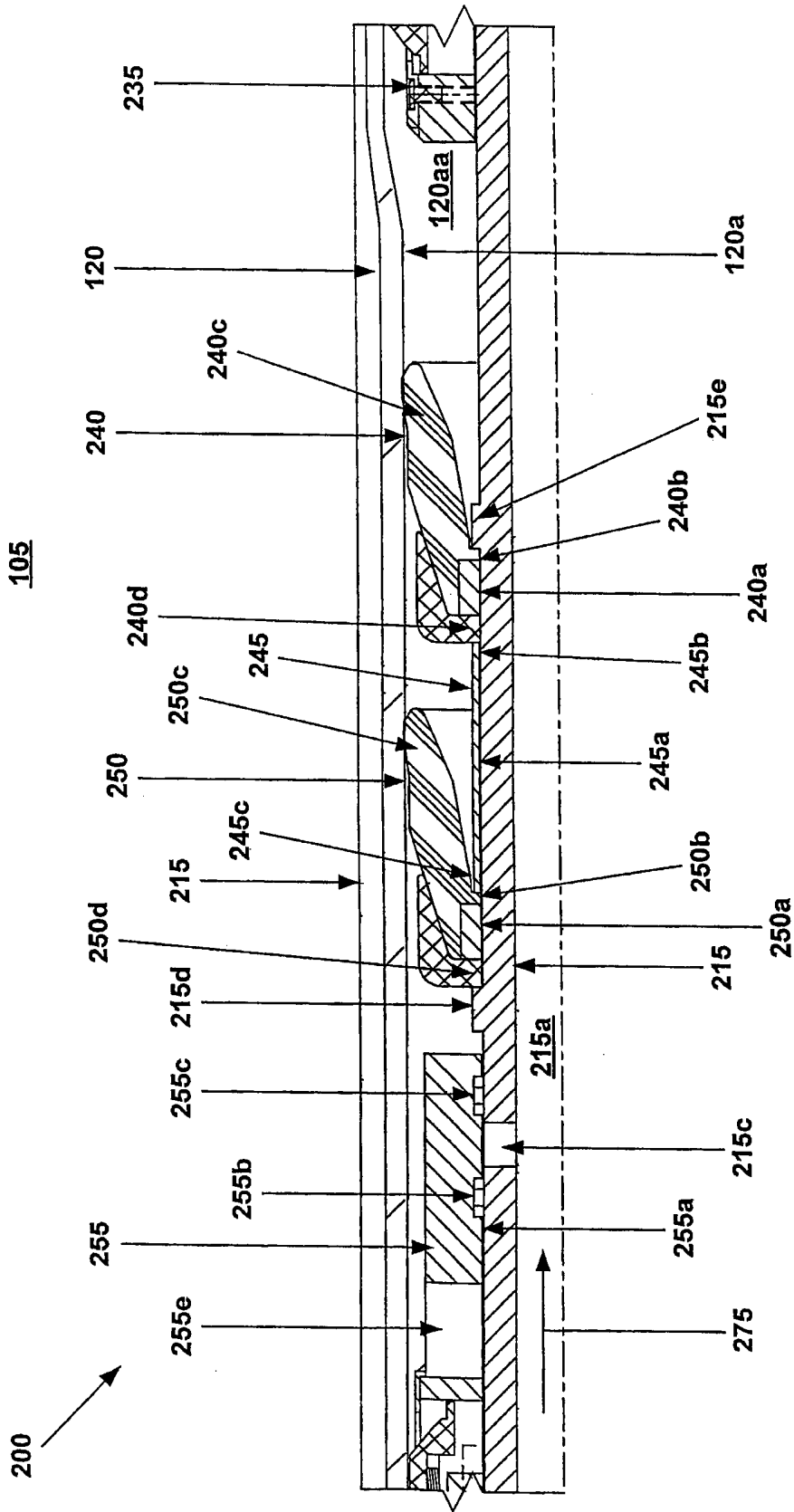

Fig. 2b

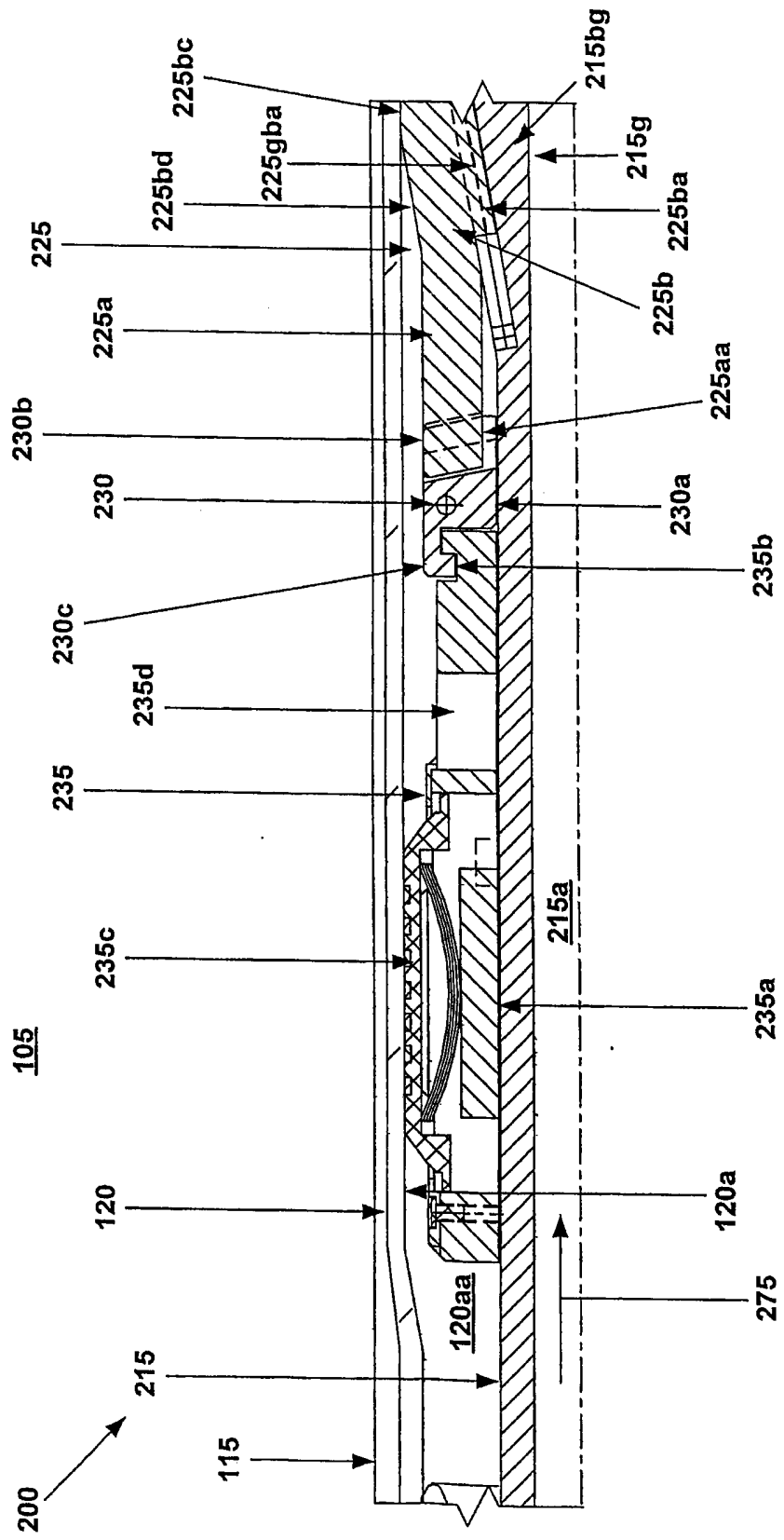

Fig. 2c

200 →

105

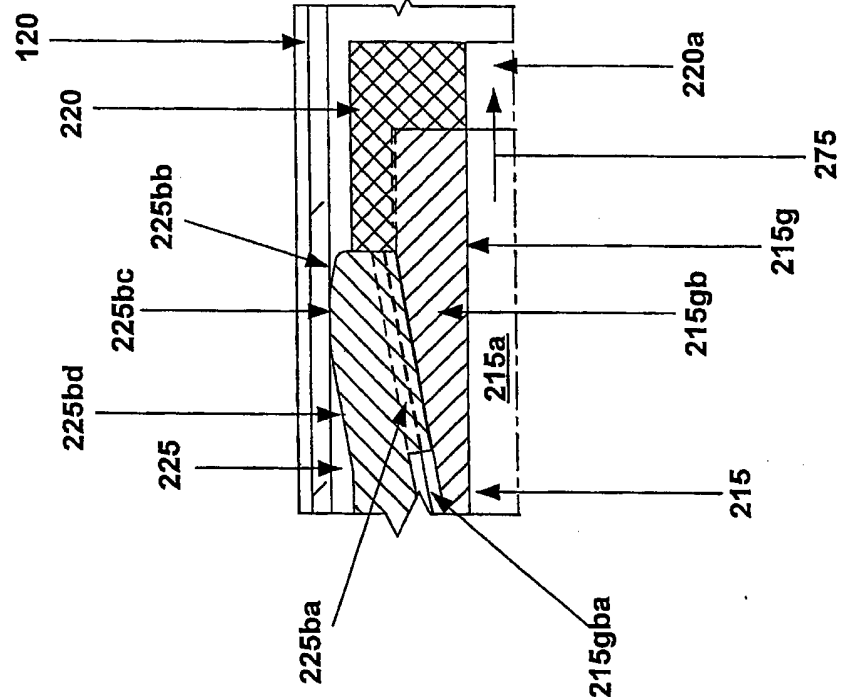

Fig. 2d

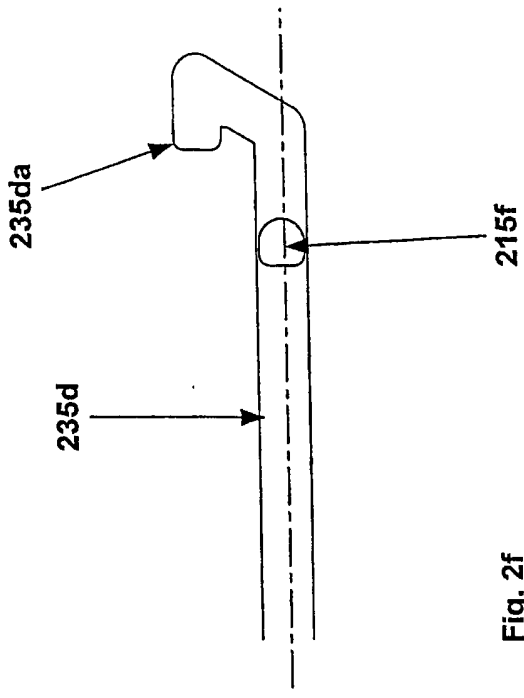

Fig. 2f

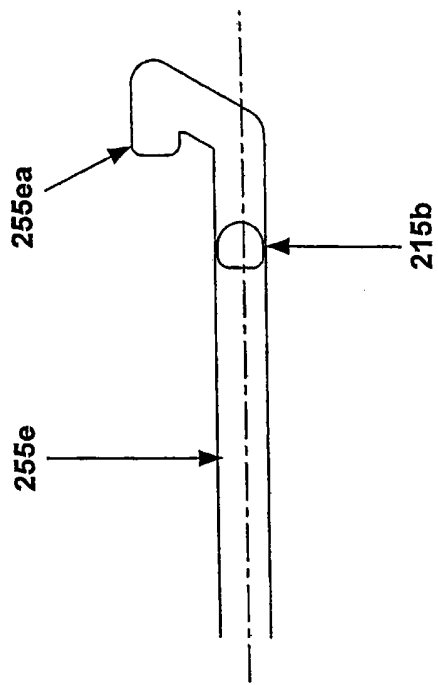

Fig. 2e

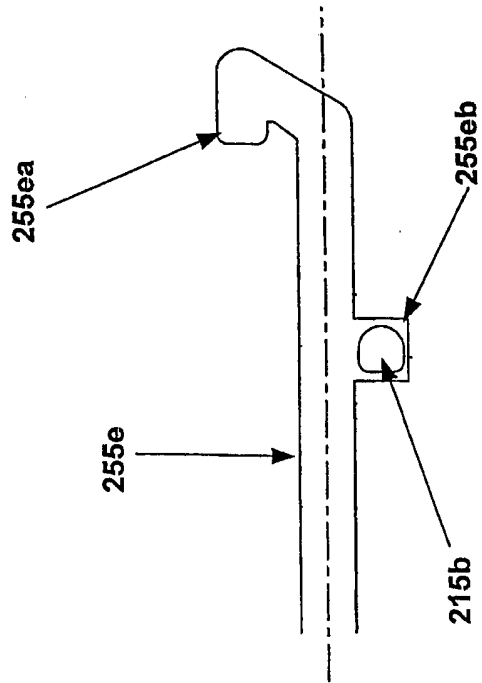

Fig. 2g

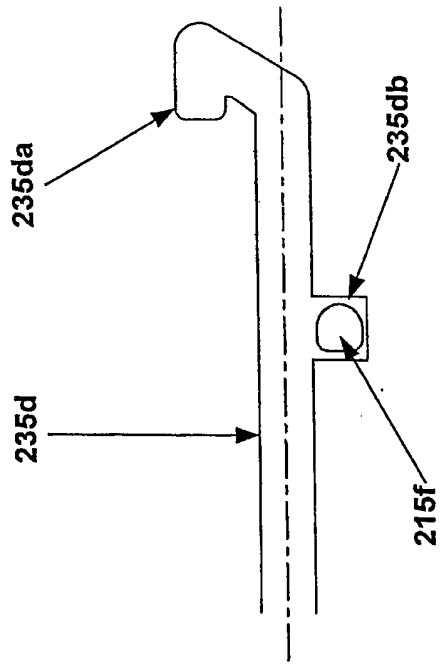

Fig. 2h

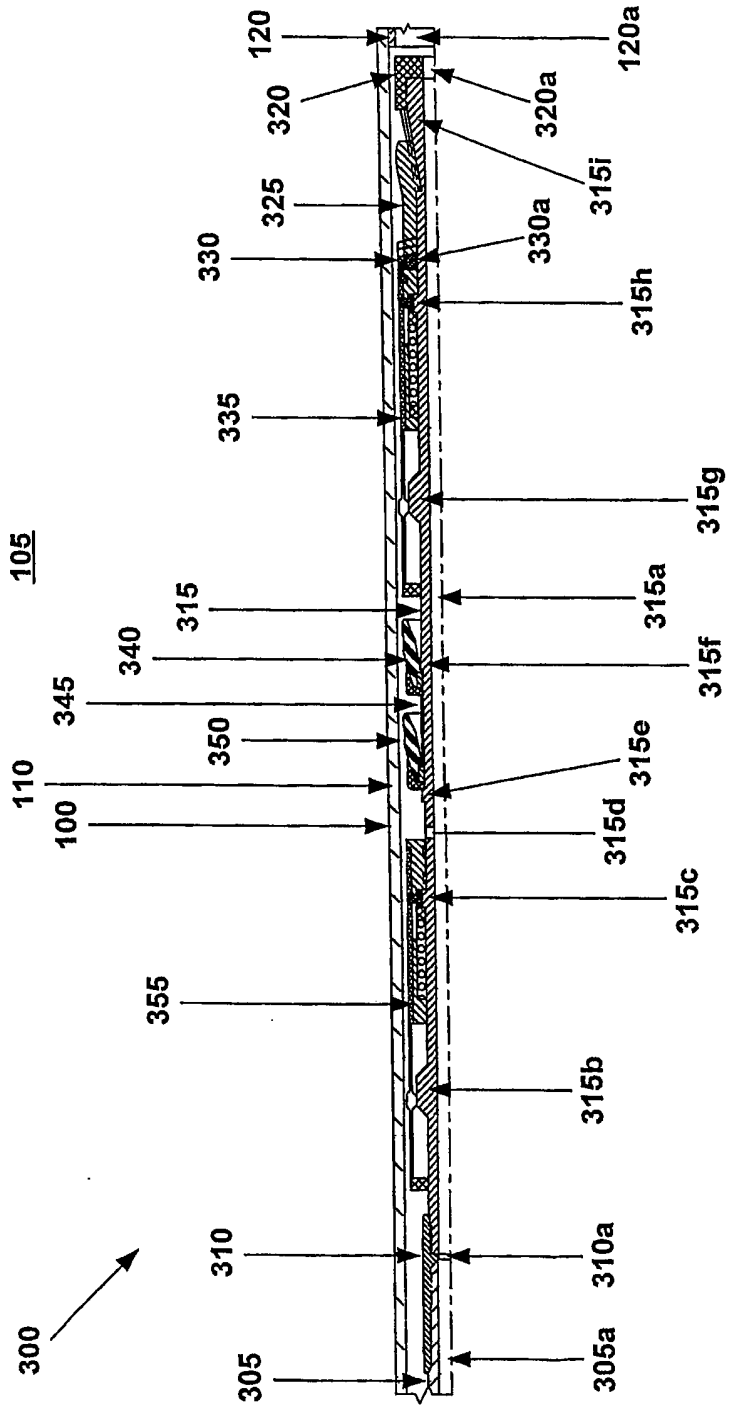

Fig. 3

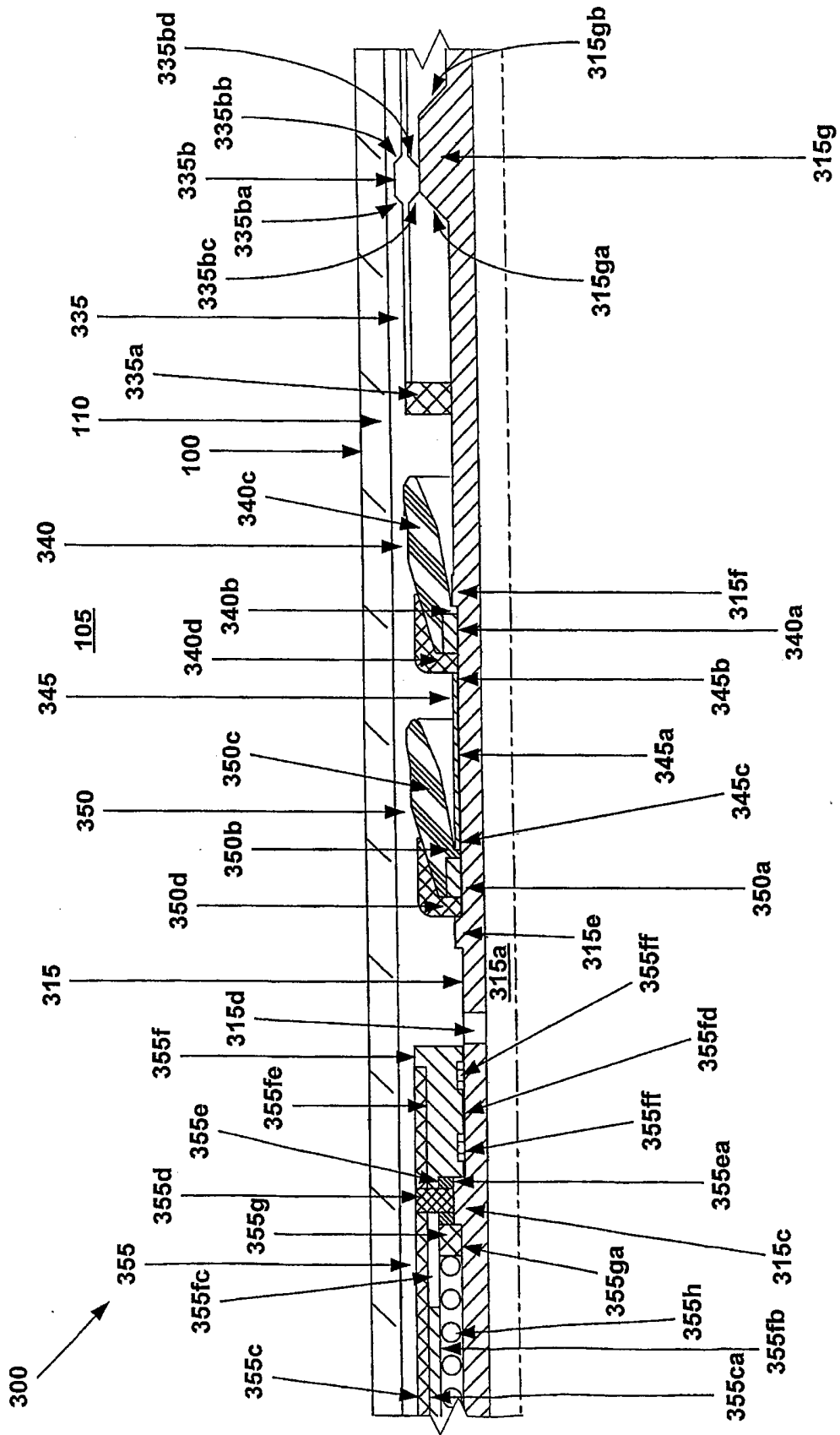

Fig. 3b

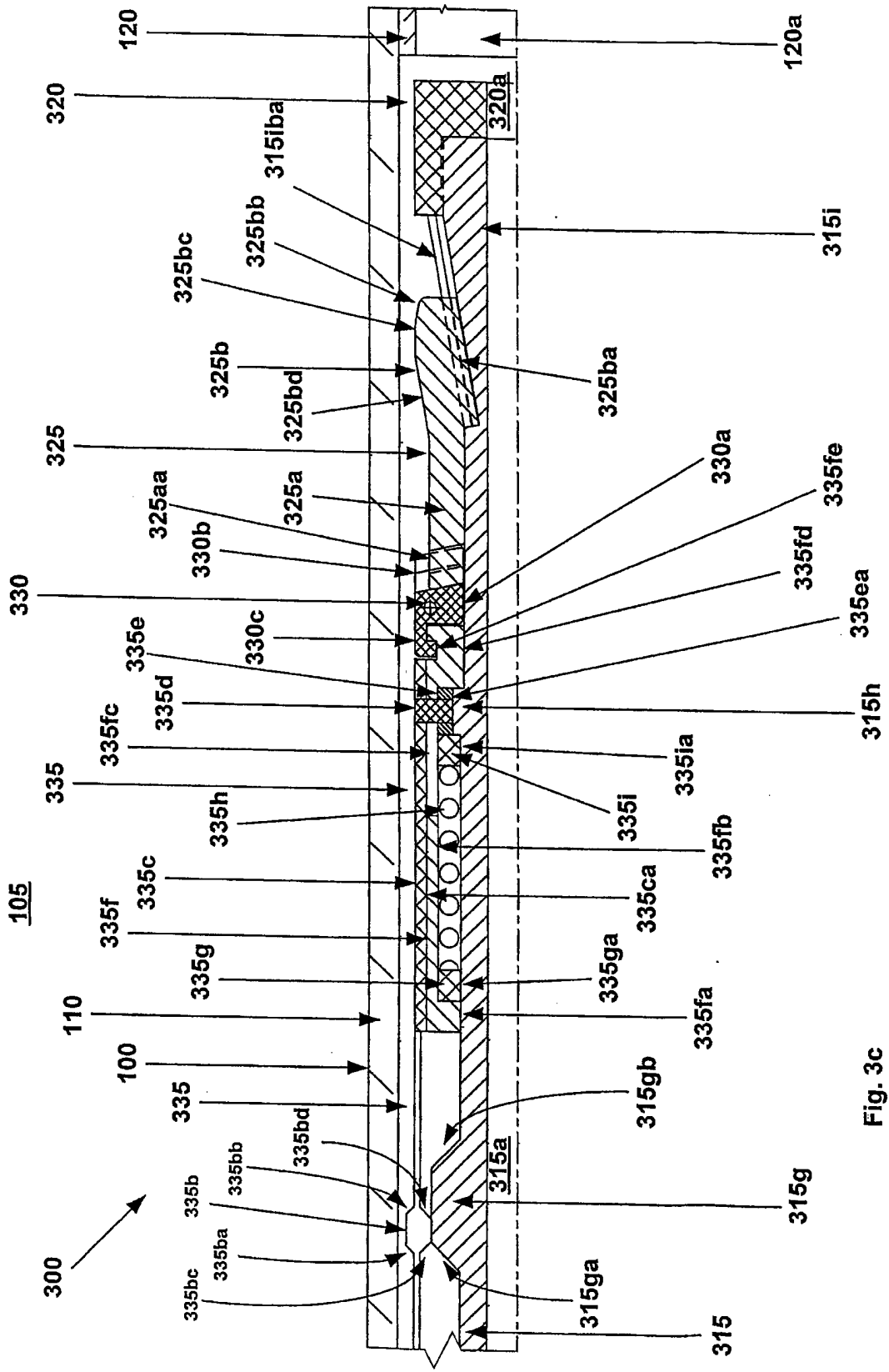

Fig. 3c

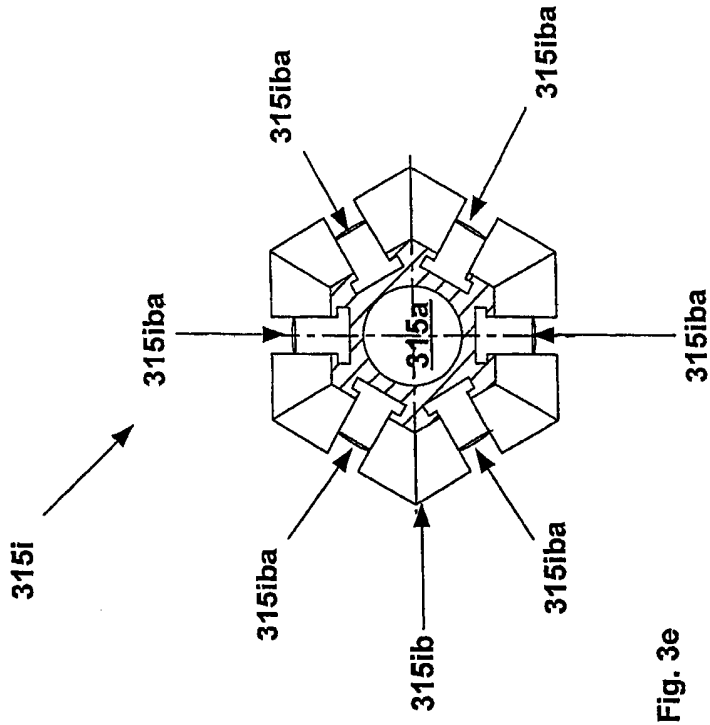

Fig. 3e

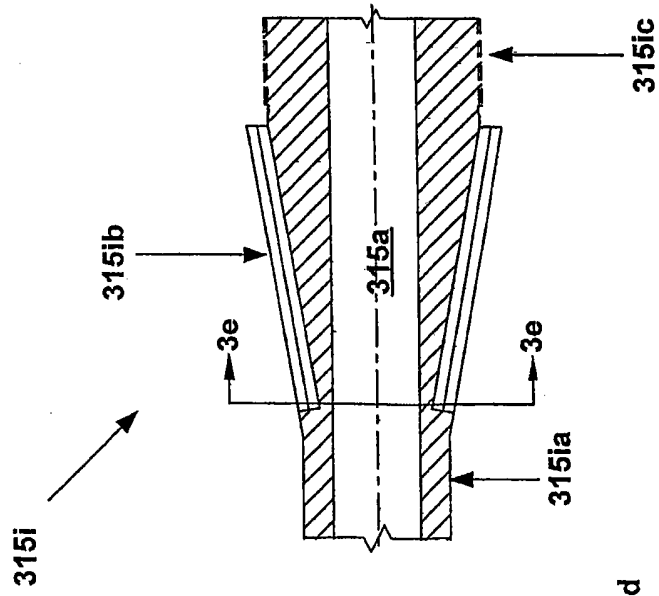

Fig. 3d

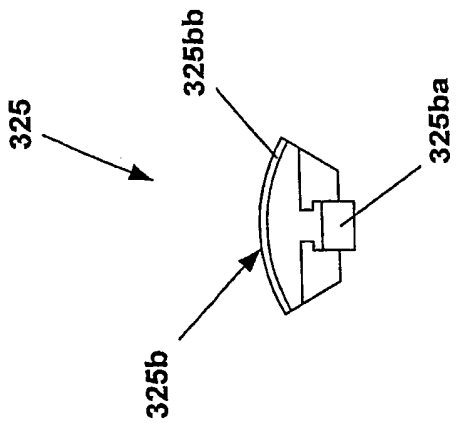

Fig. 3g

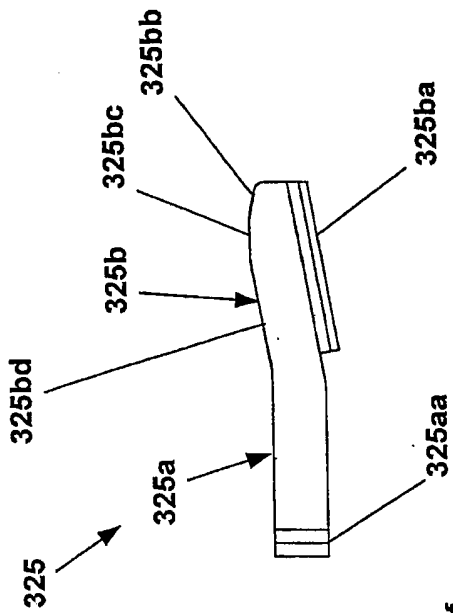

Fig. 3f

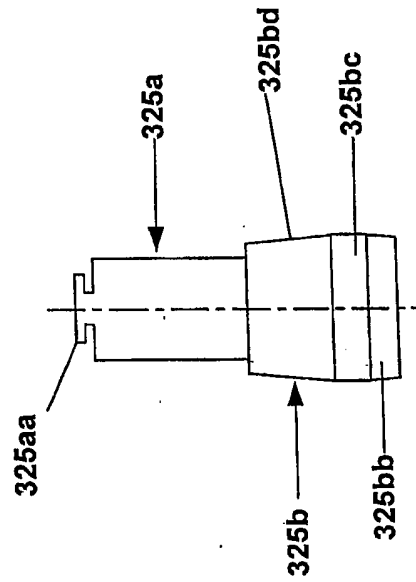

Fig. 3h

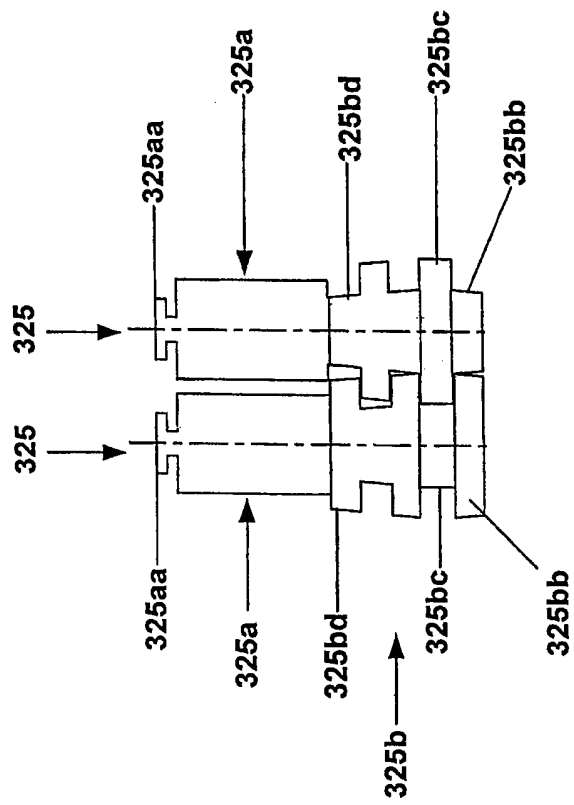

Fig. 3I

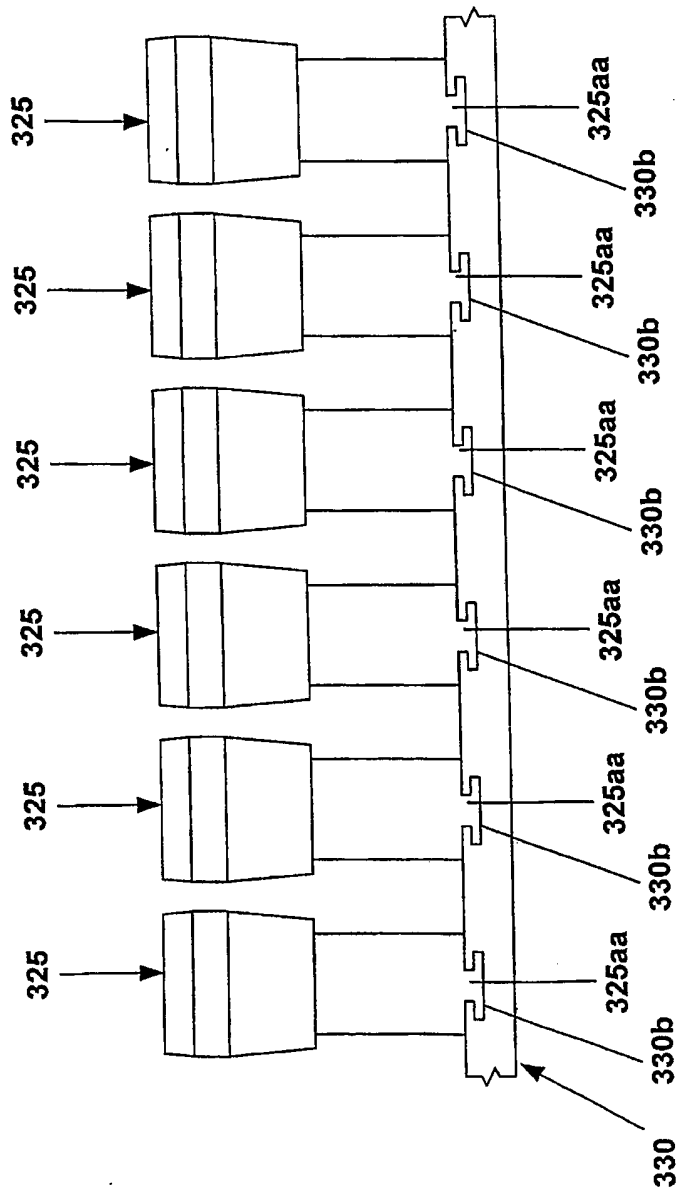

Fig. 3j

105

300 ↗

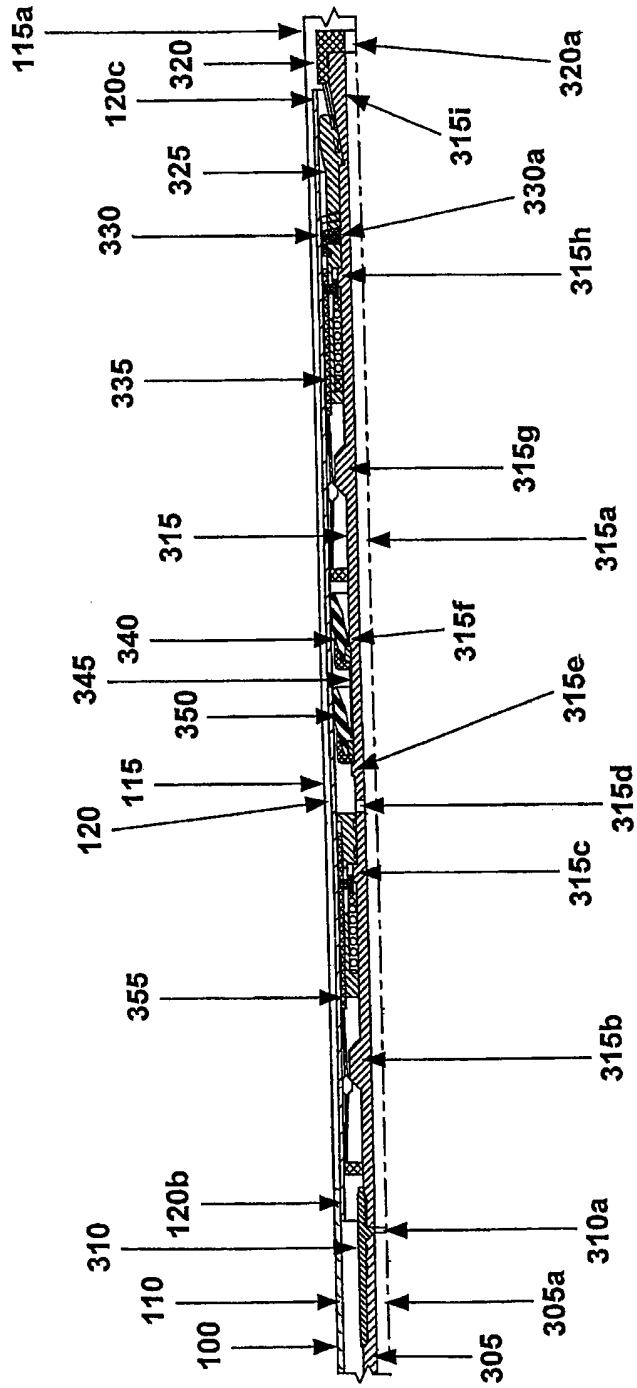

Fig. 4

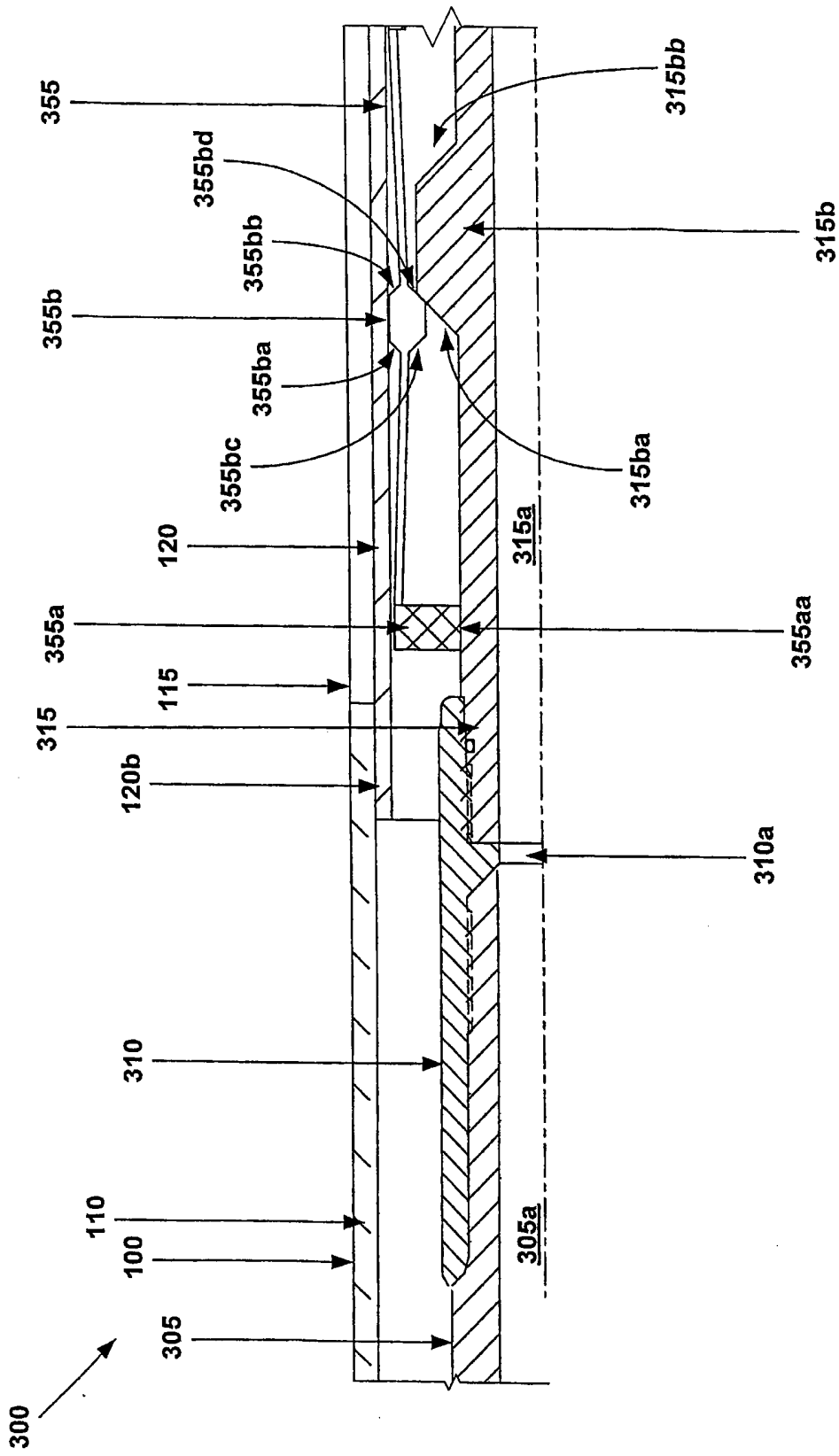

Fig. 4a

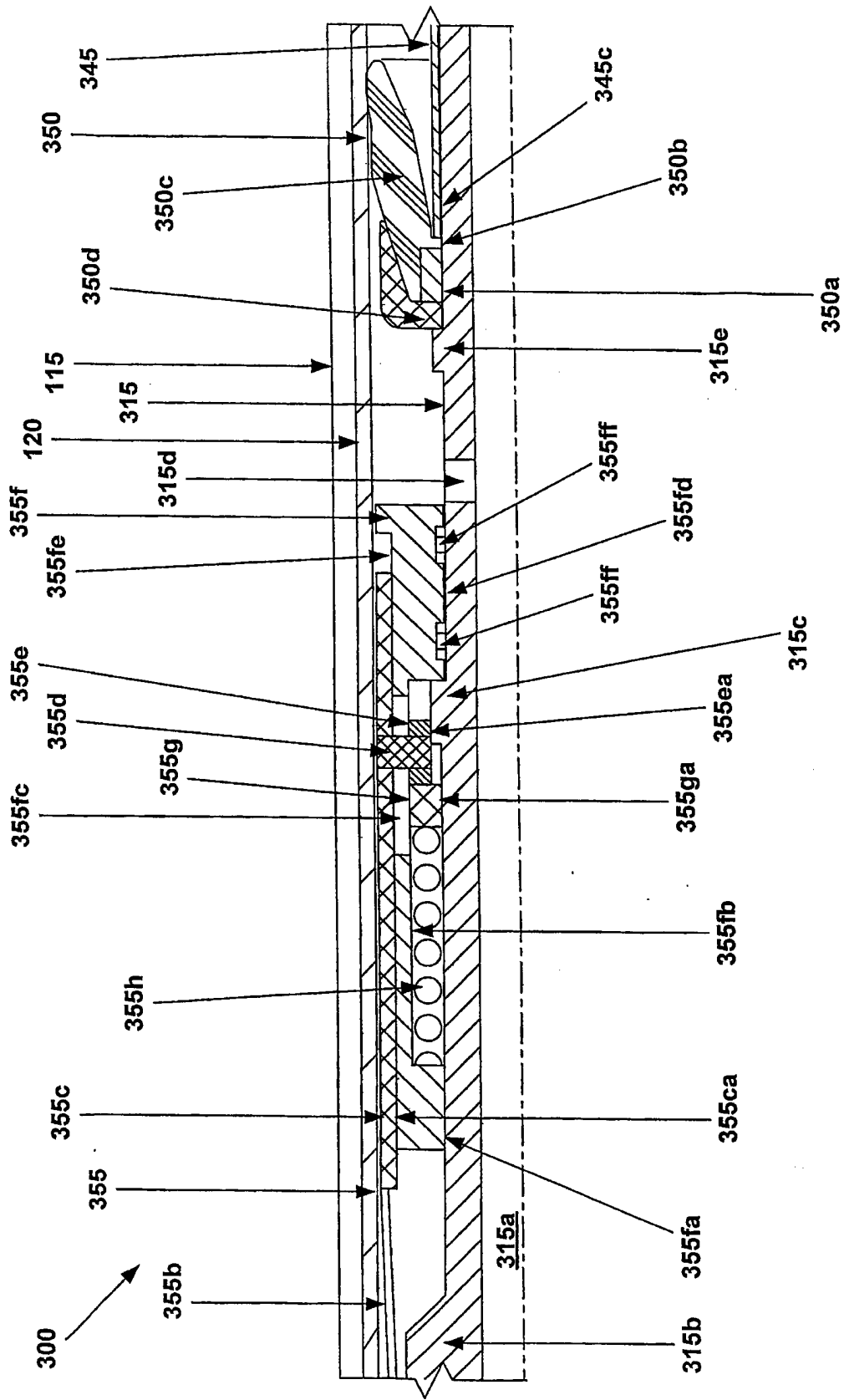

Fig. 4b

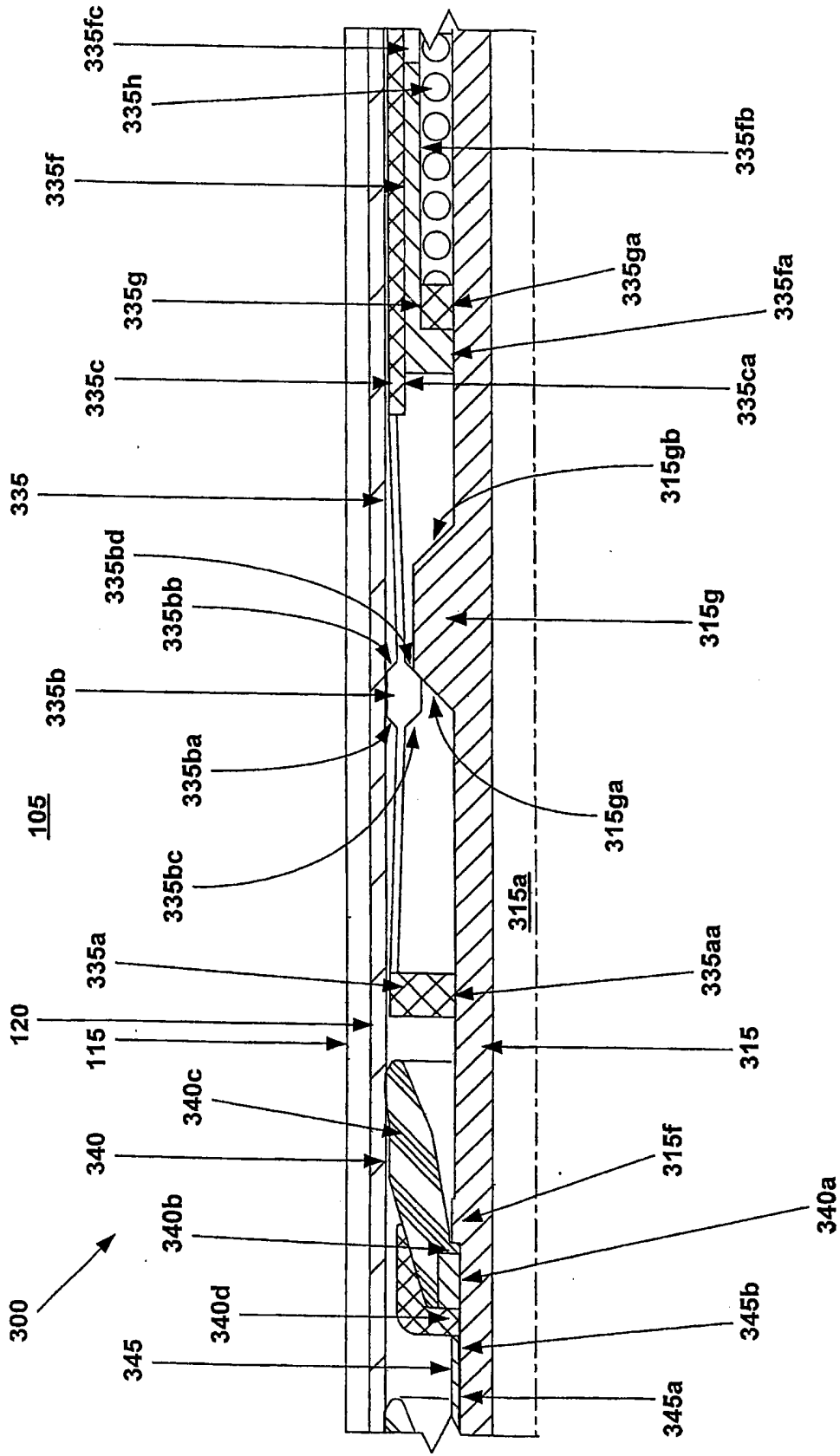

Fig. 4c

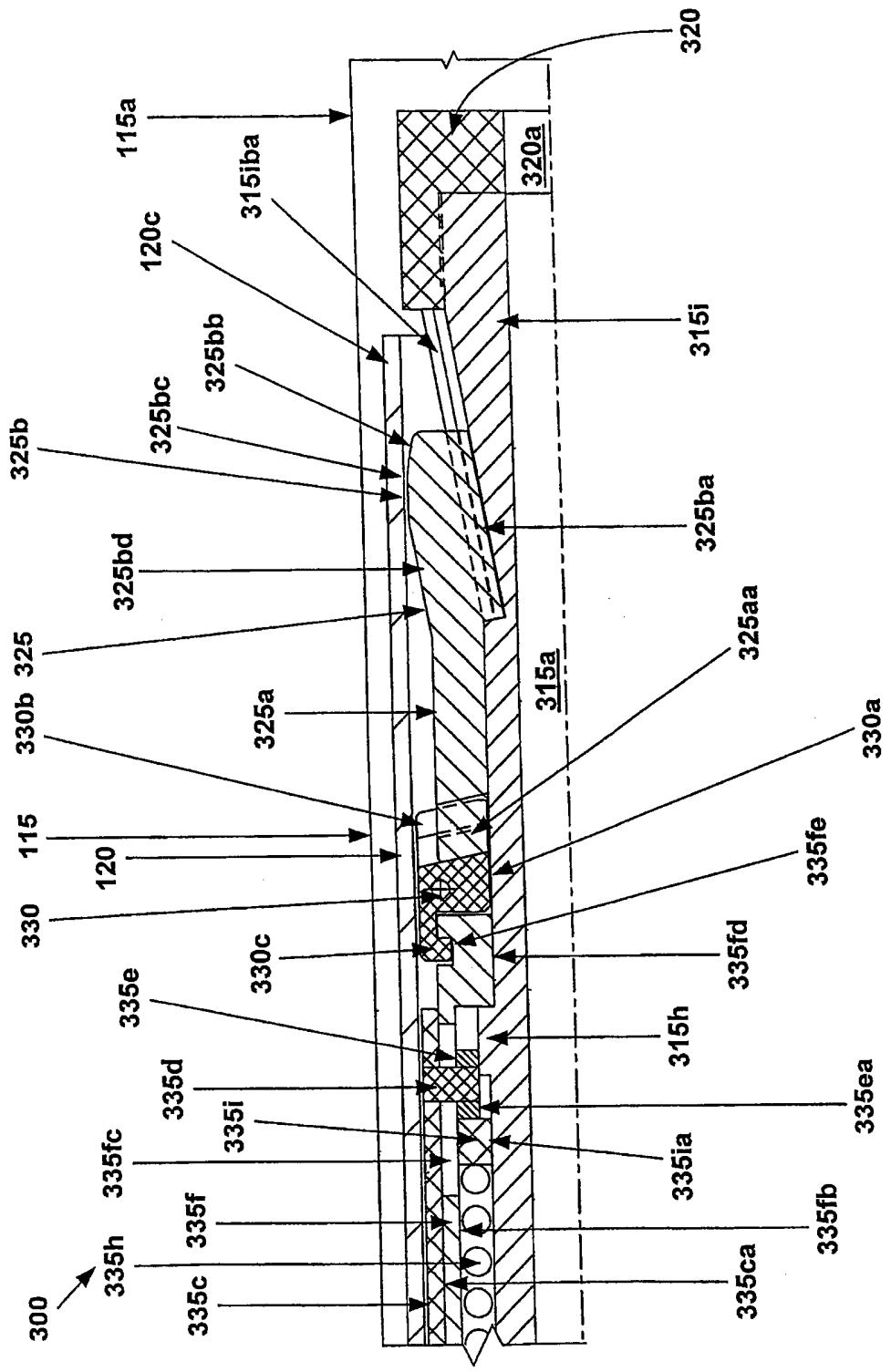

Fig. 4d

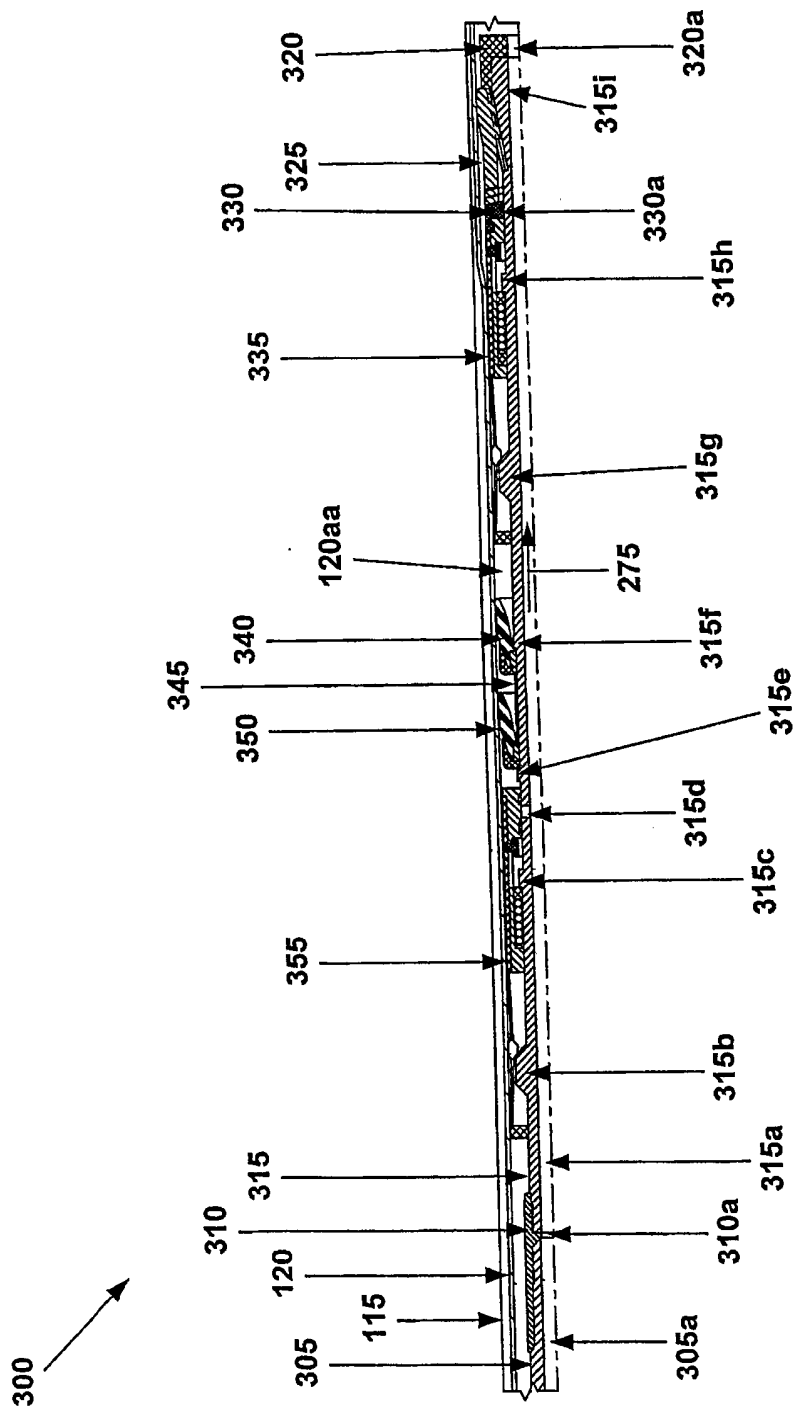

Fig. 5

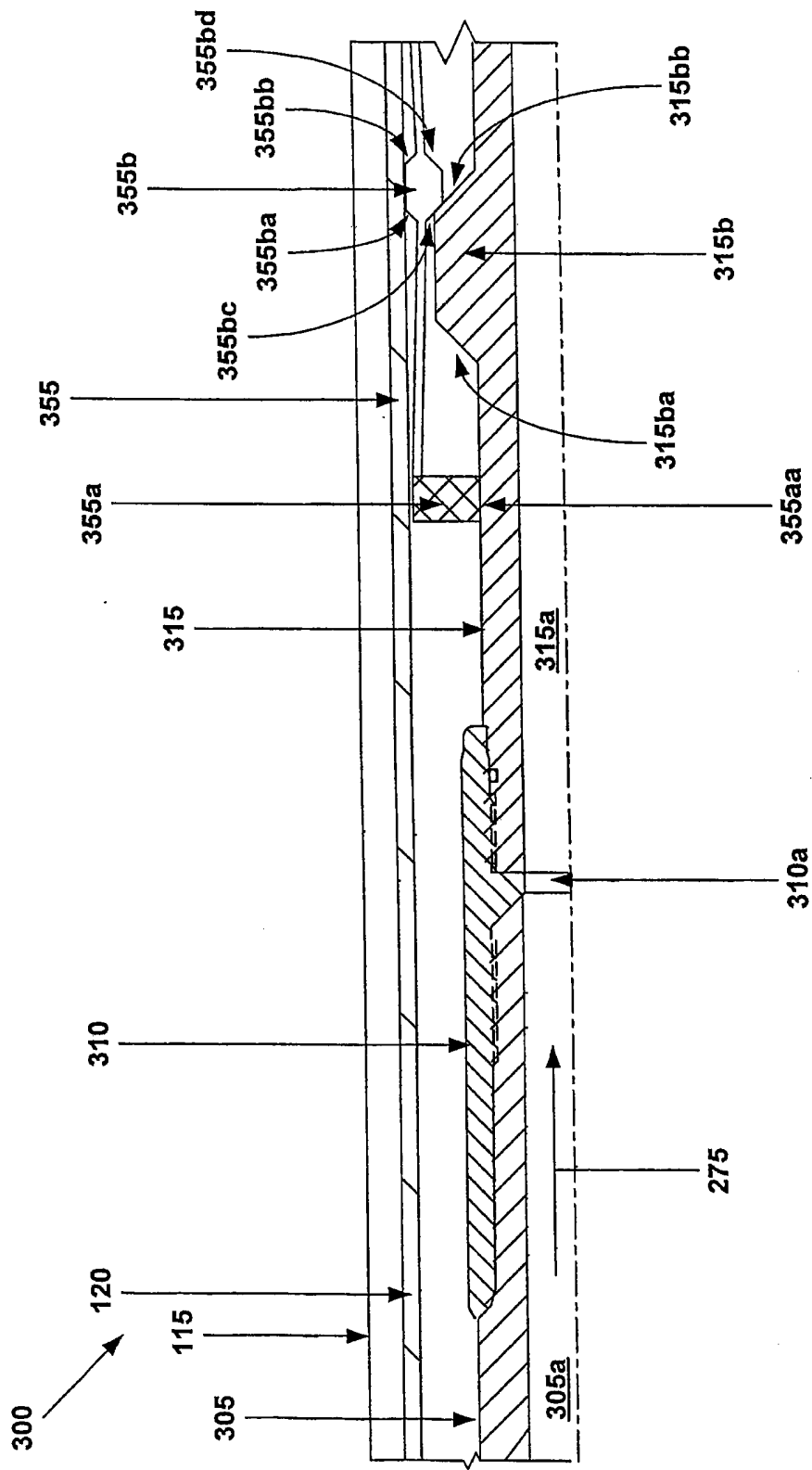

Fig. 5a

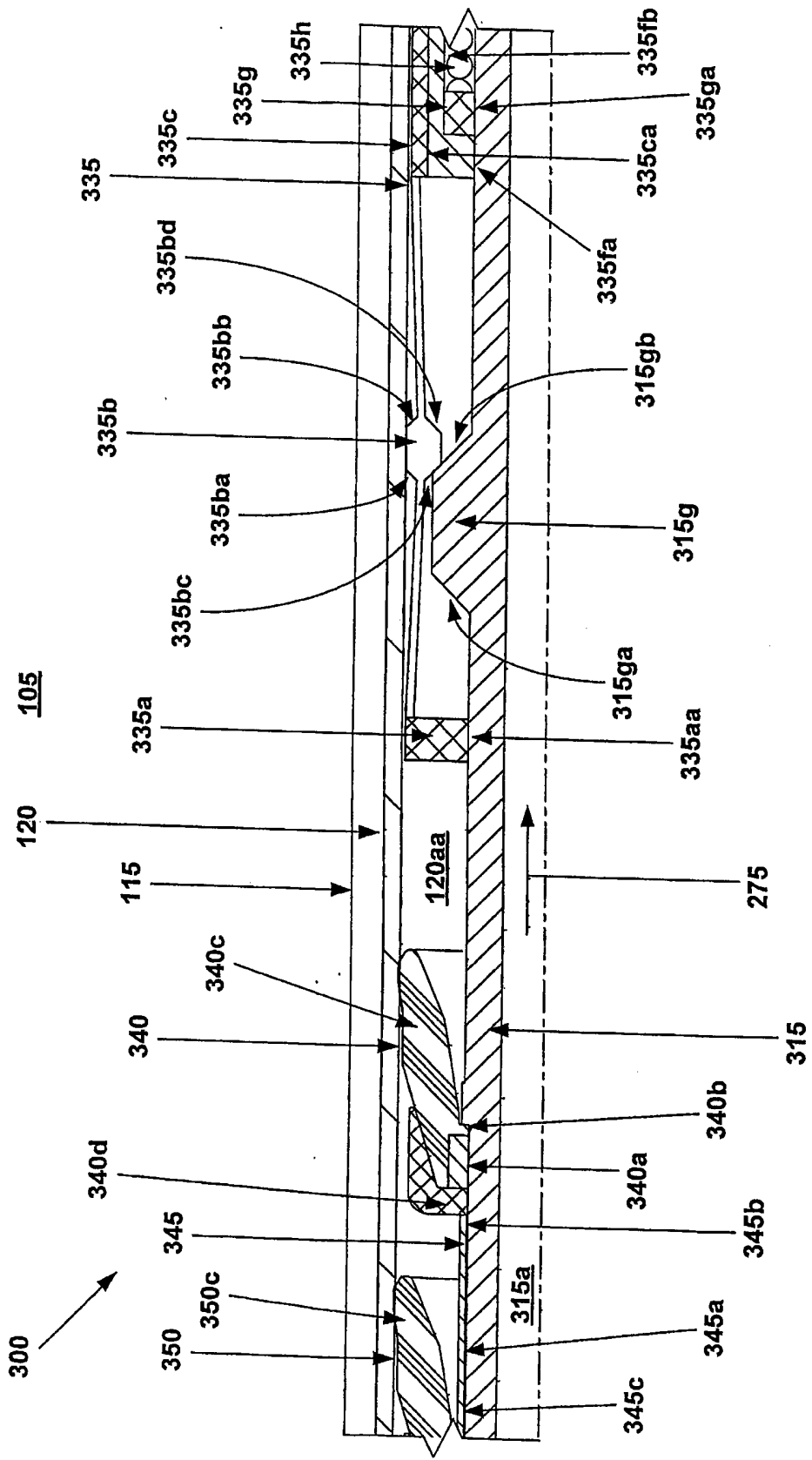

Fig. 5c

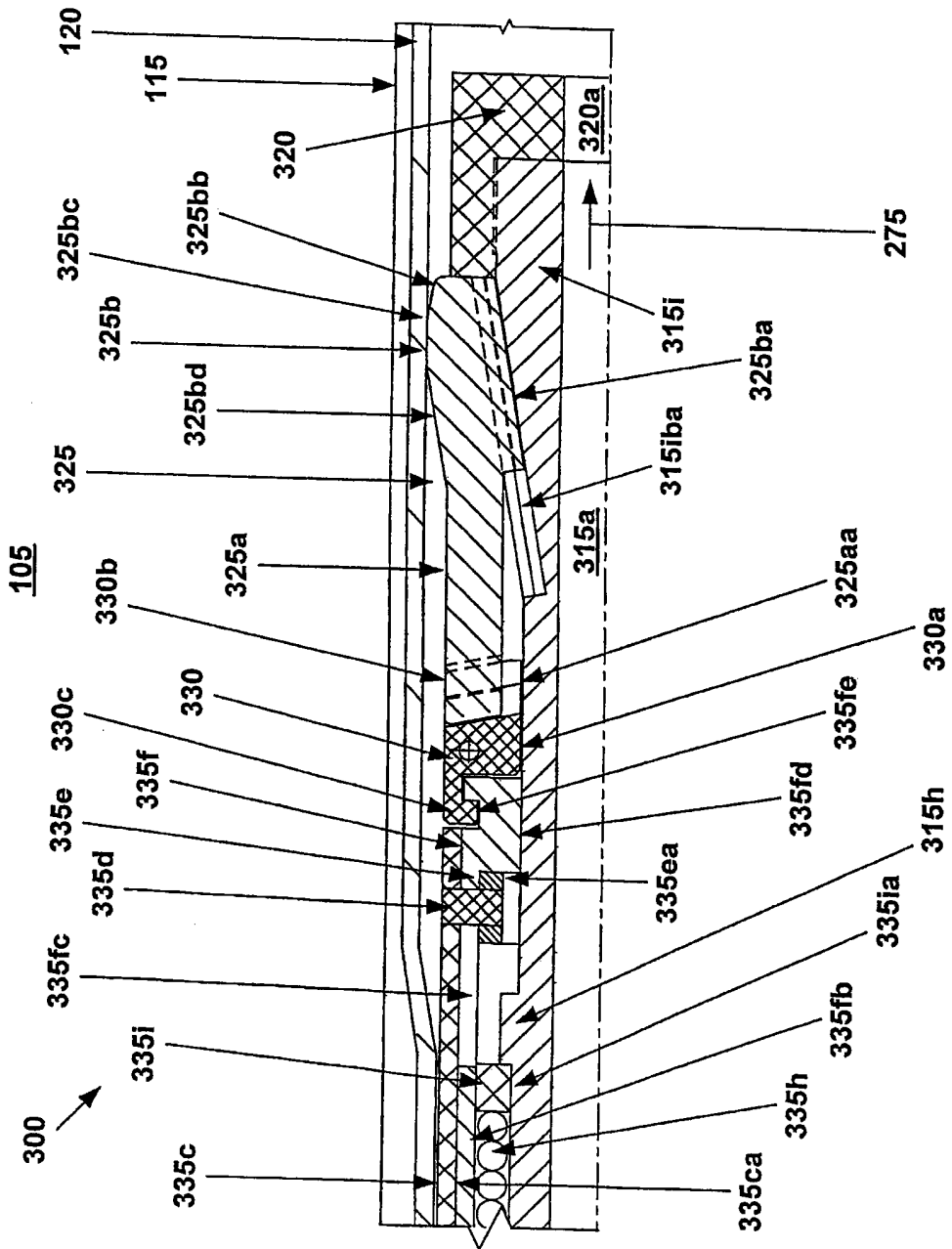

Fig. 5d

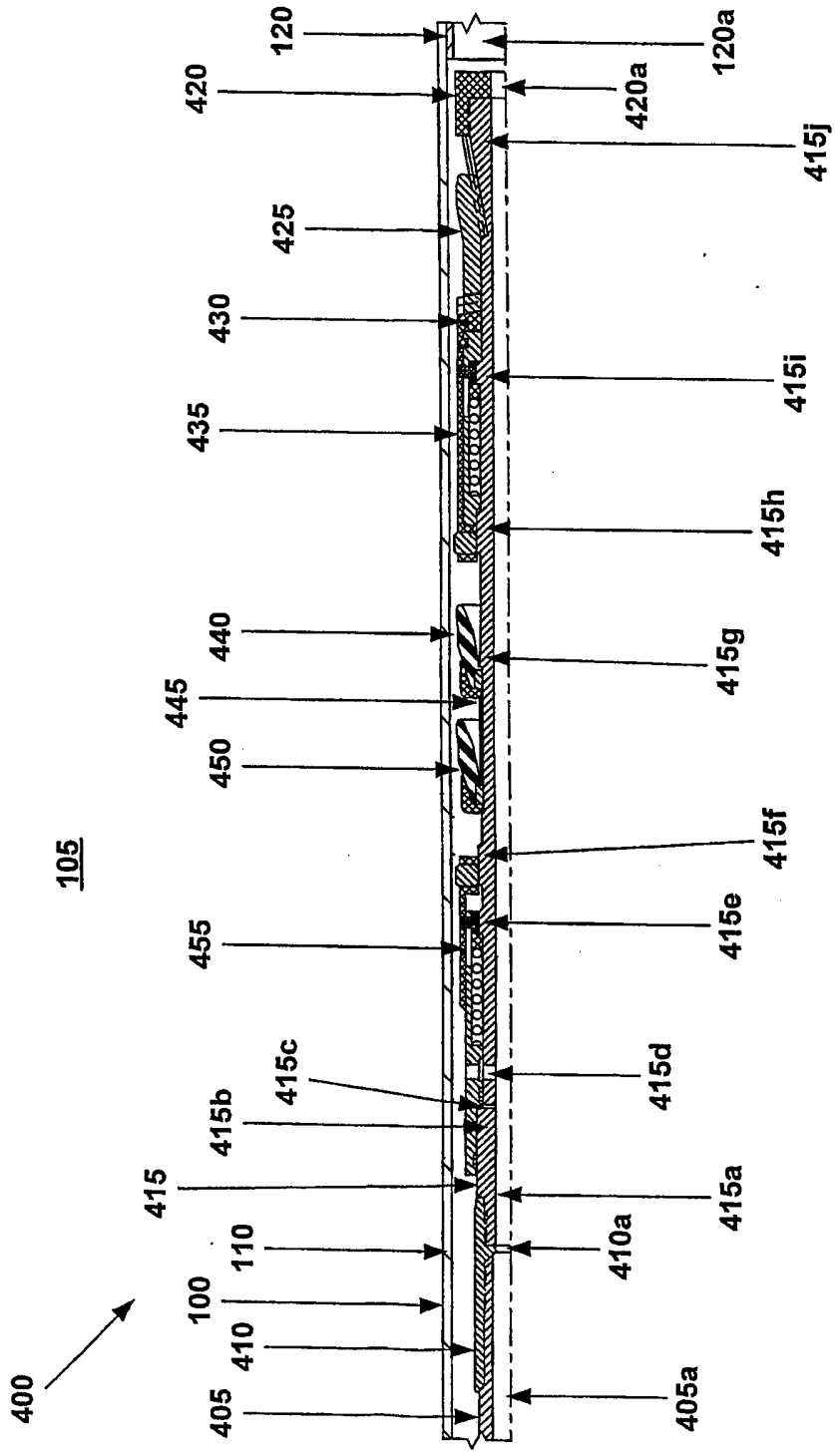

Fig. 6

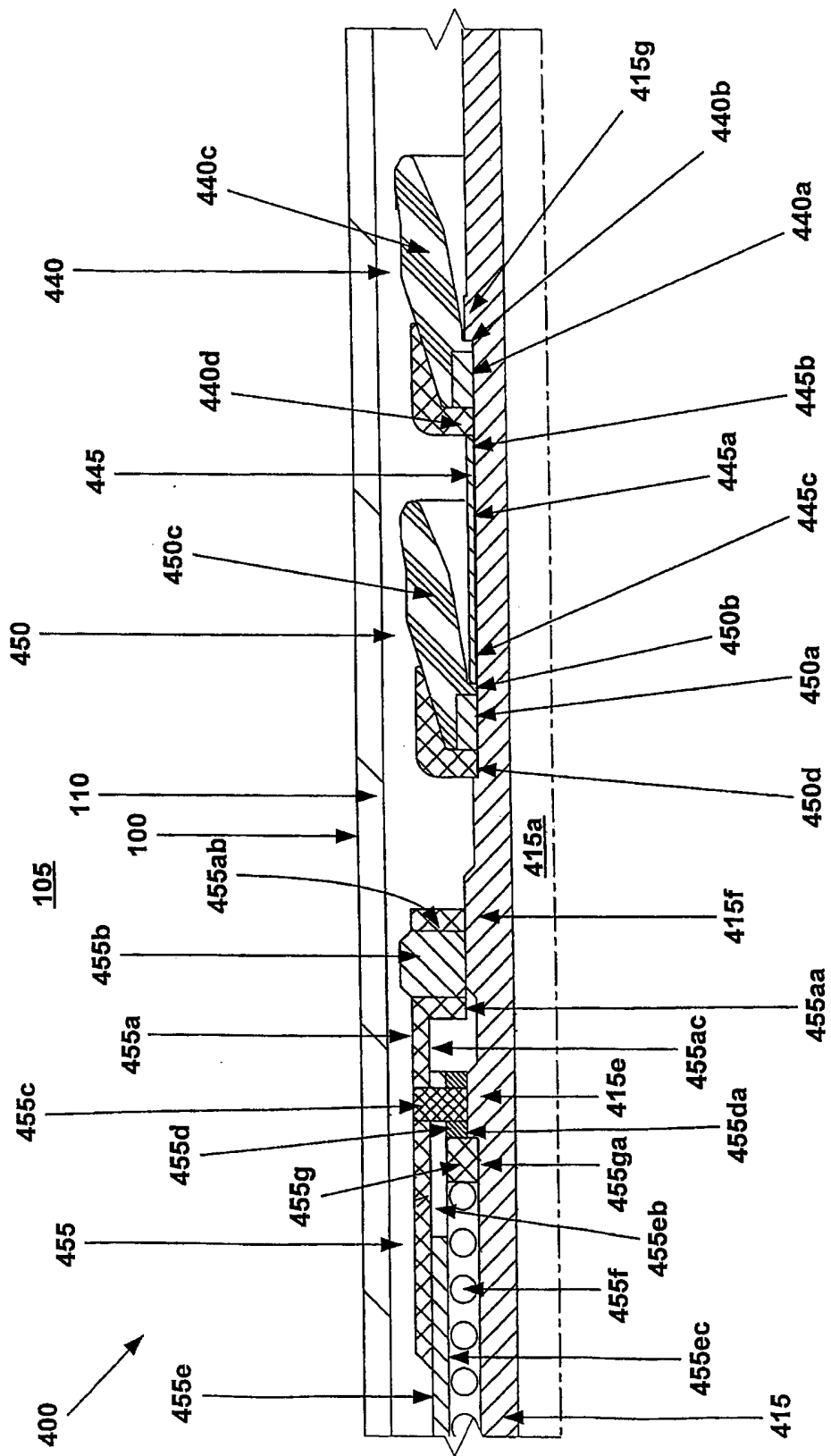

Fig. 6b

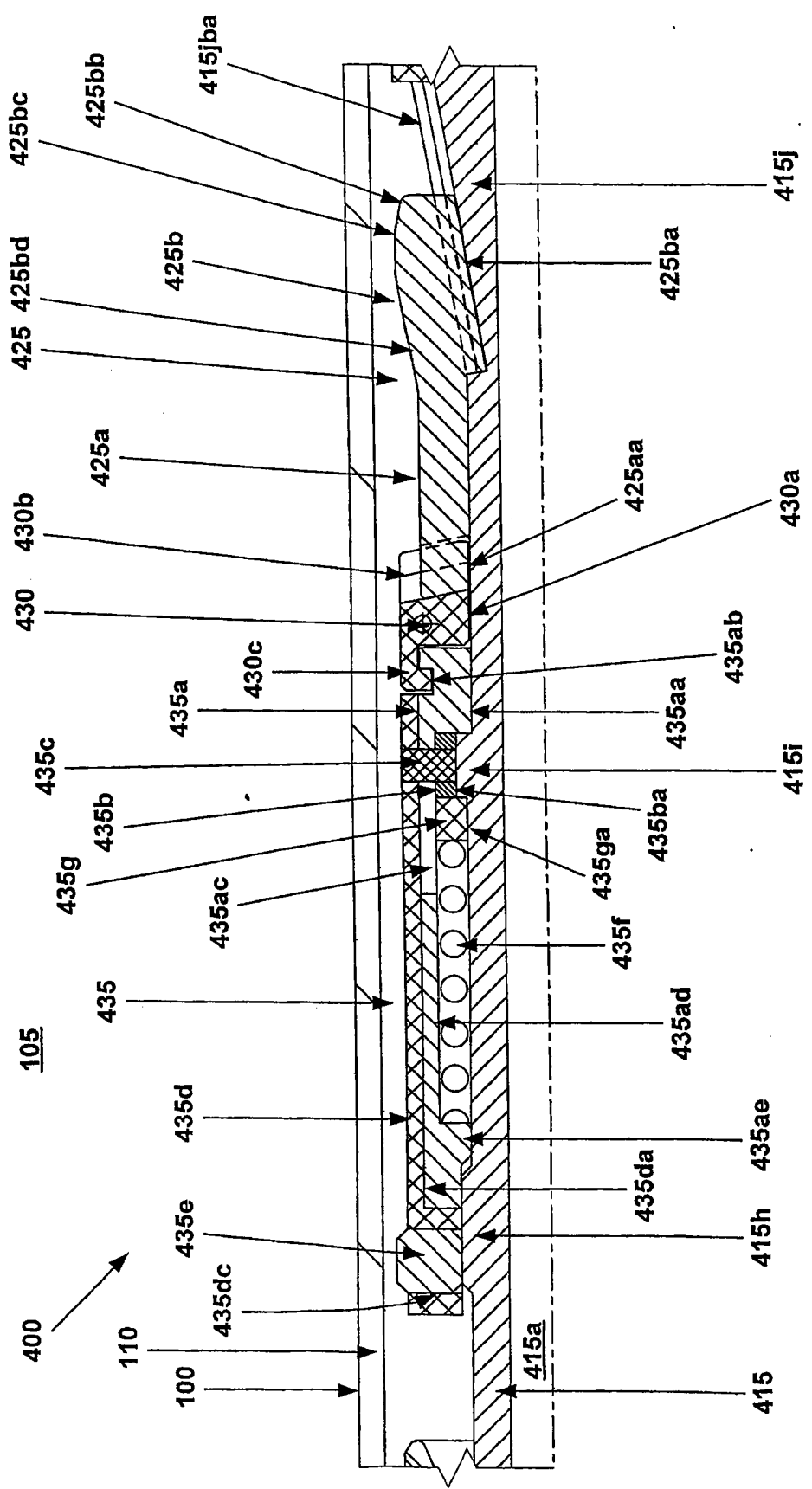

Fig. 6c

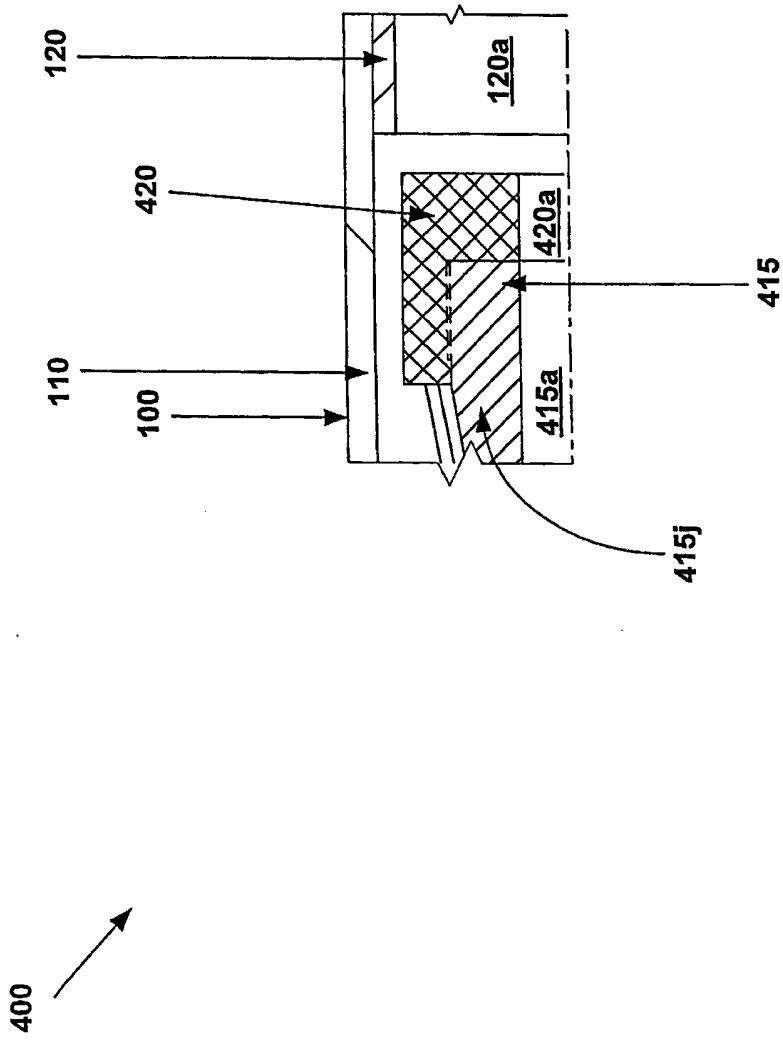

Fig. 6d

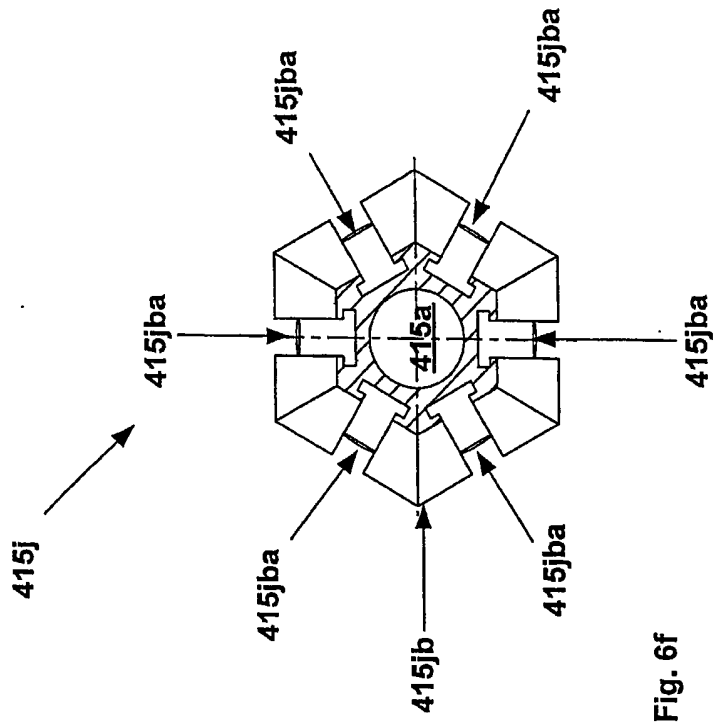

Fig. 6f

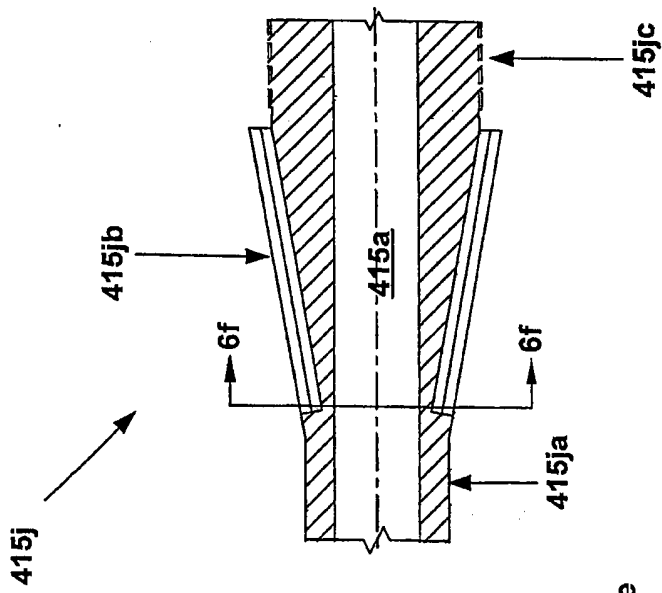

Fig. 6e

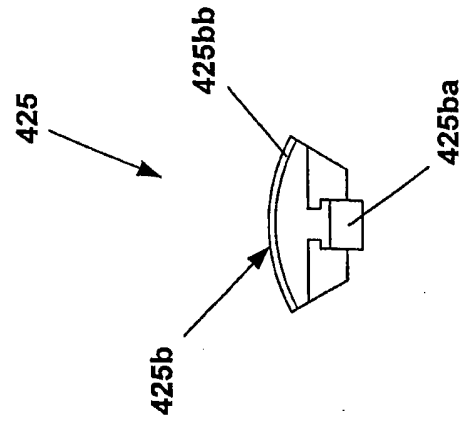

Fig. 6h

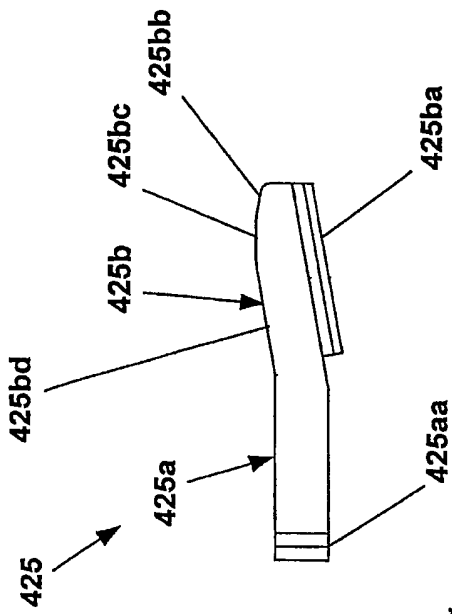

Fig. 6g

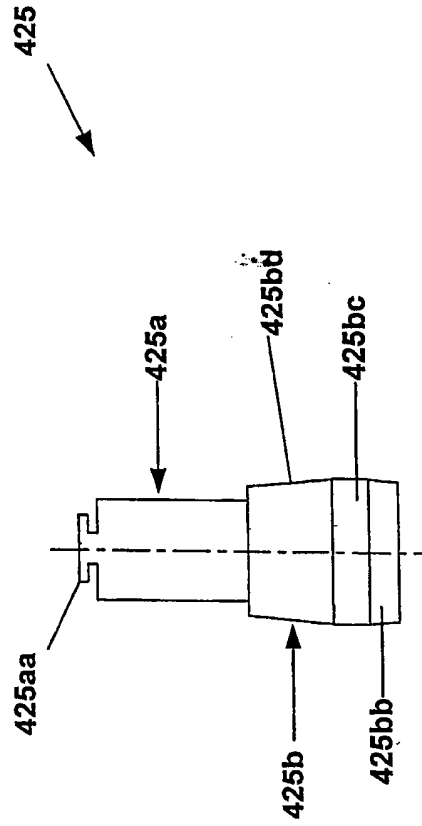

Fig. 6i

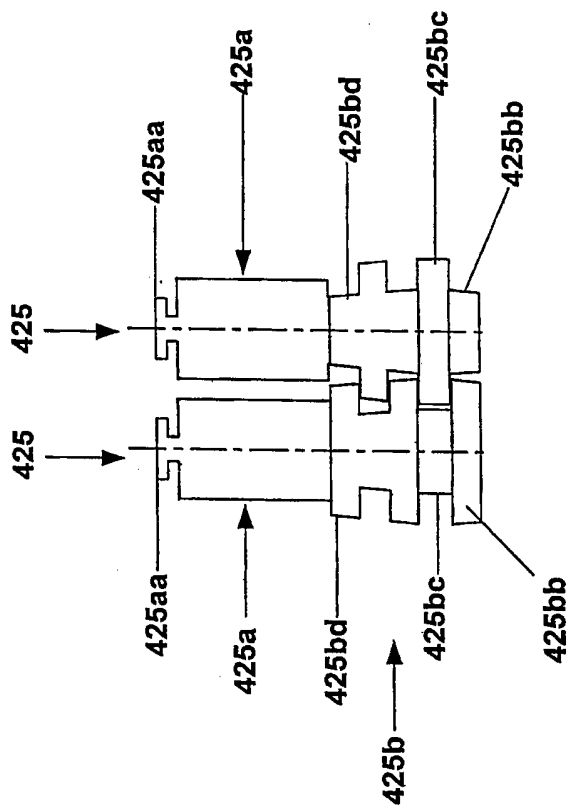

Fig. 6j

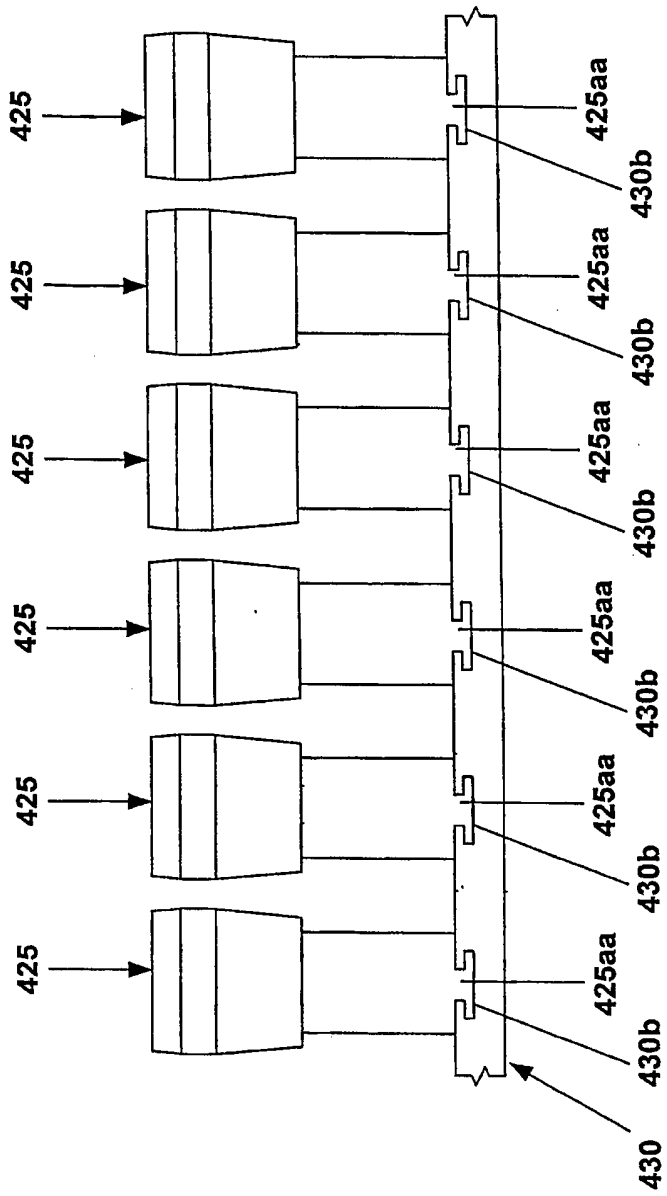

Fig. 6k

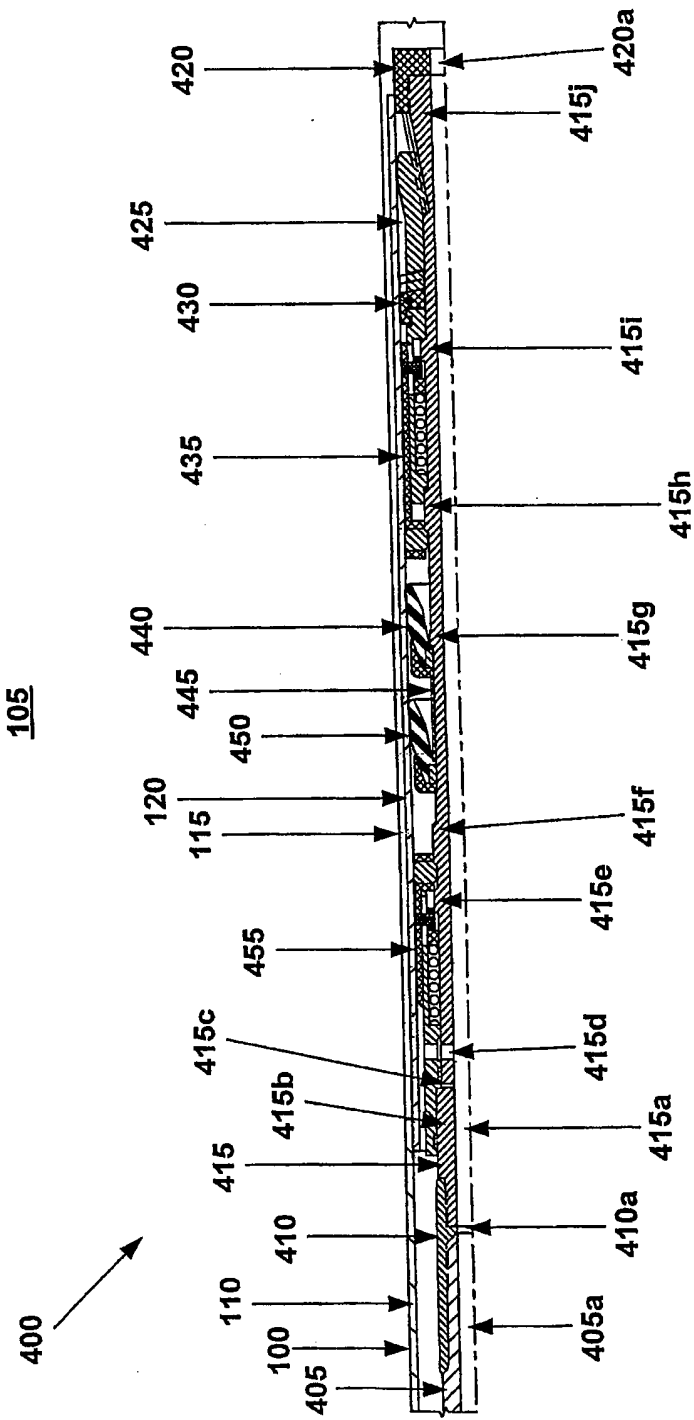

Fig. 7

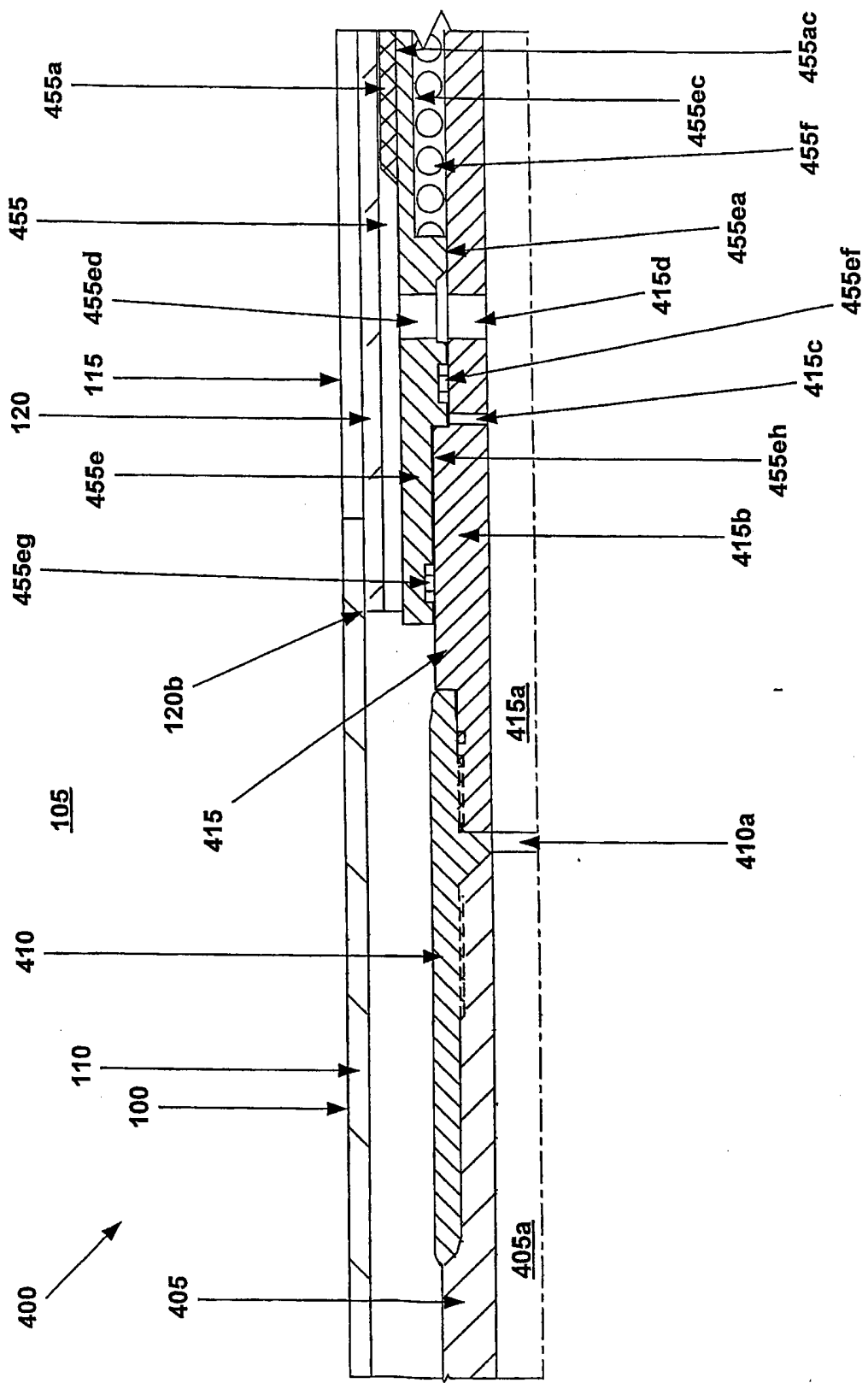

Fig. 7a

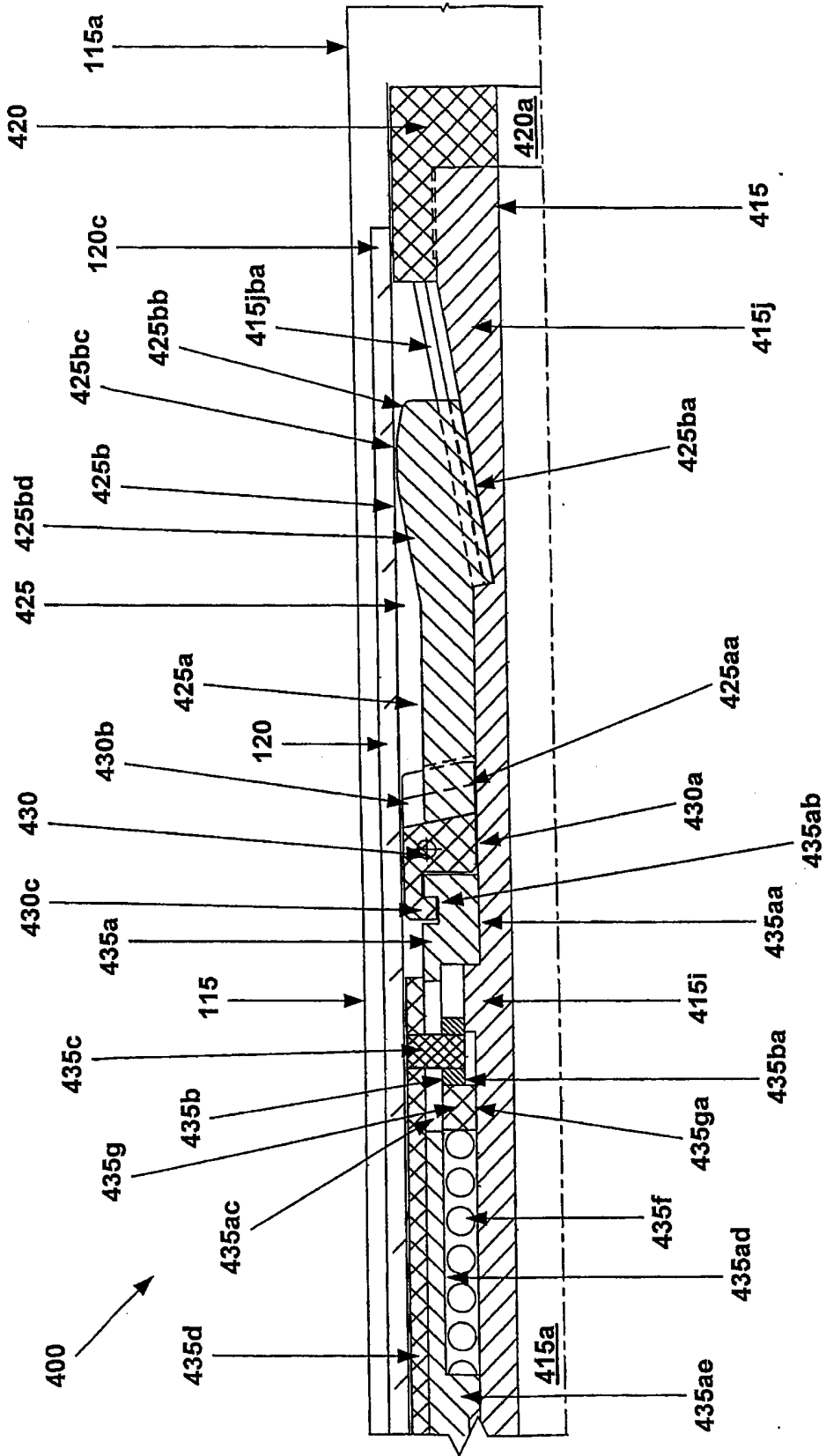

Fig. 7c

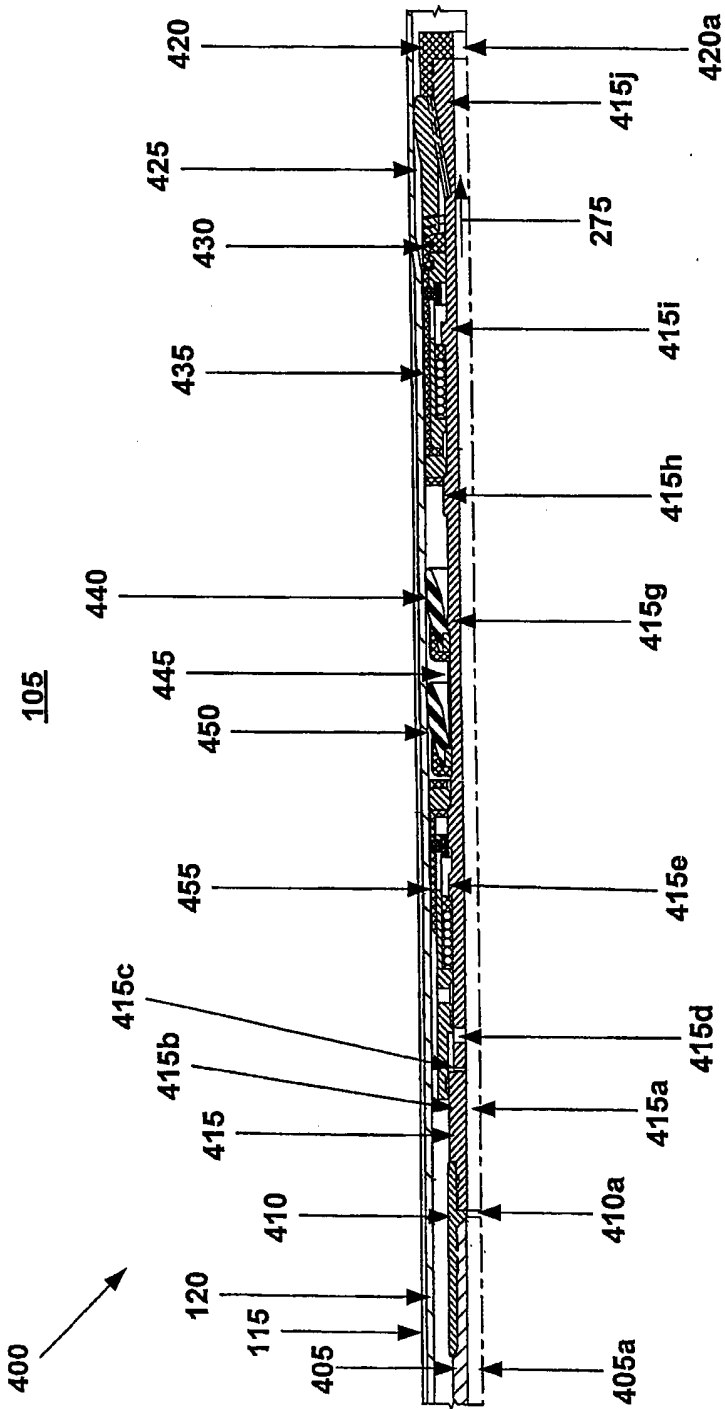

Fig. 8

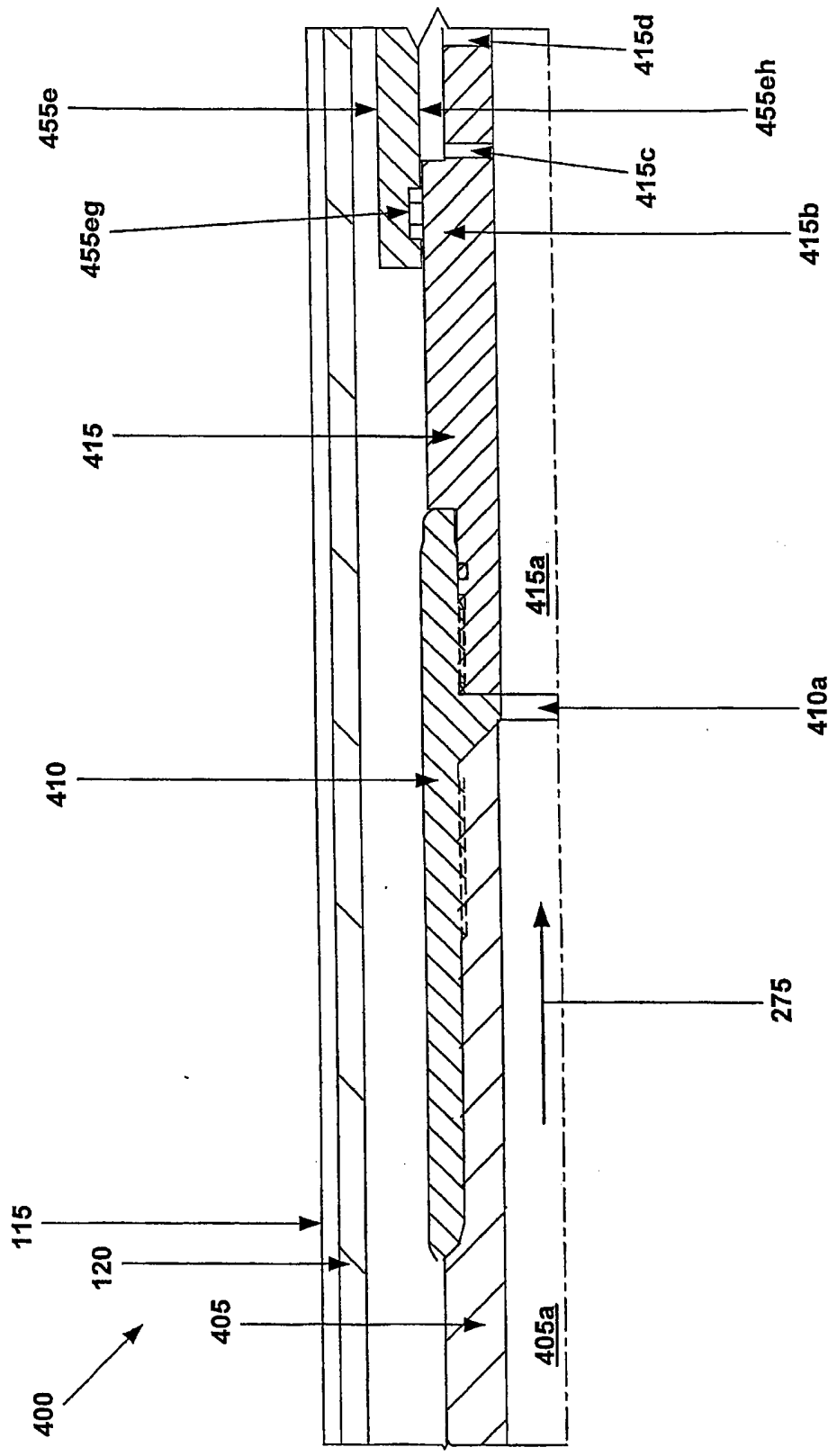

Fig. 8a

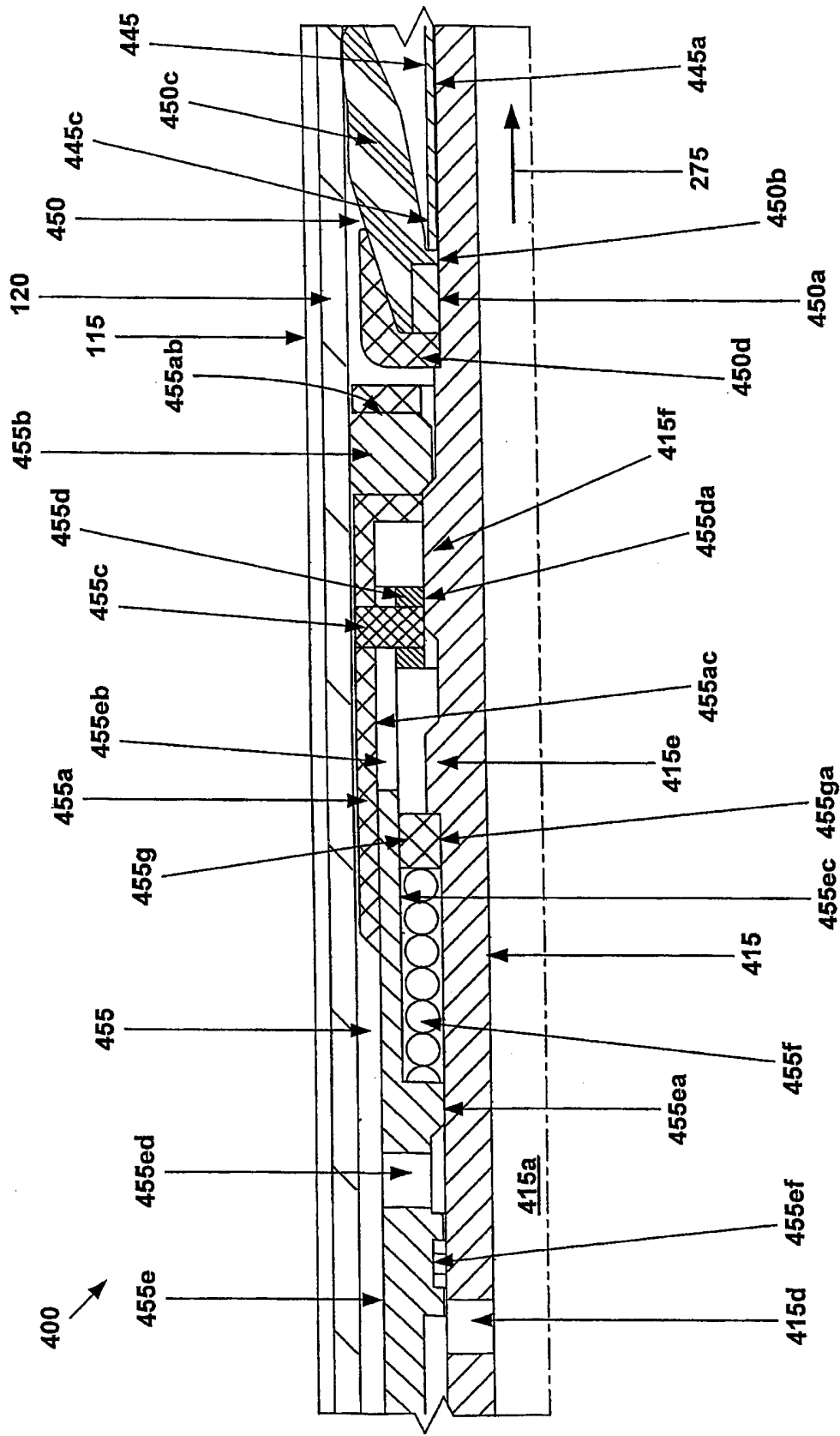

Fig. 8b

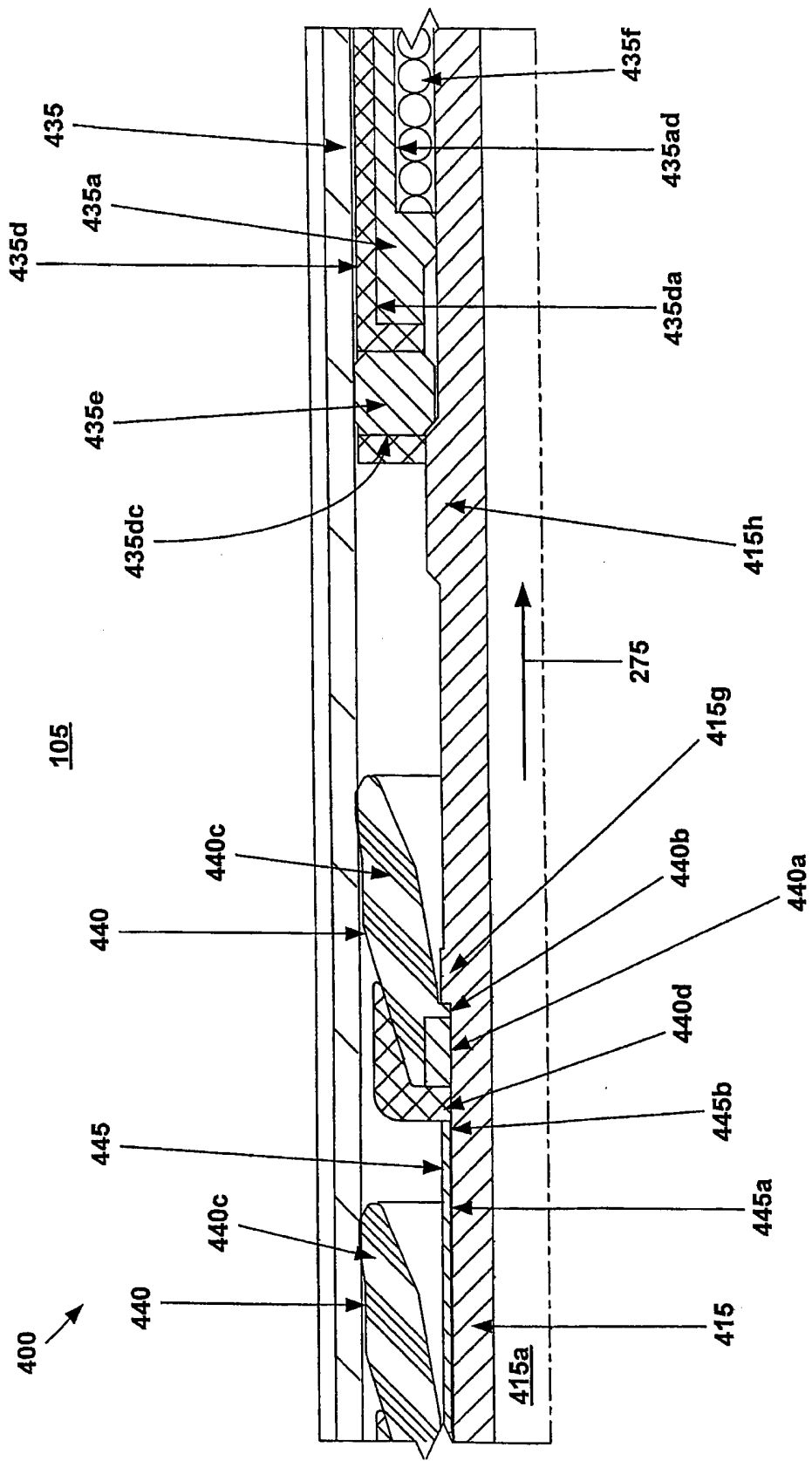

Fig. 8c

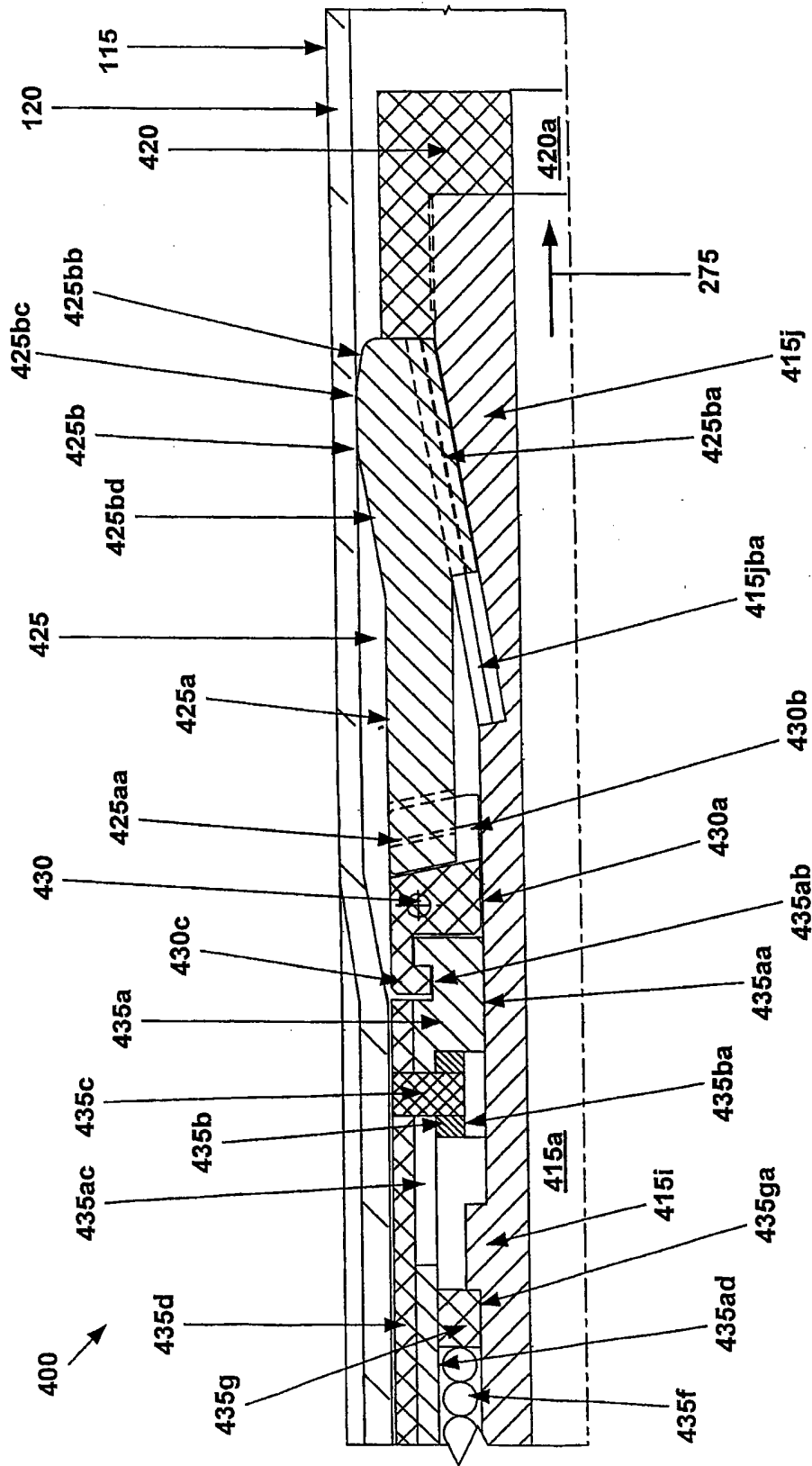

Fig. 8d

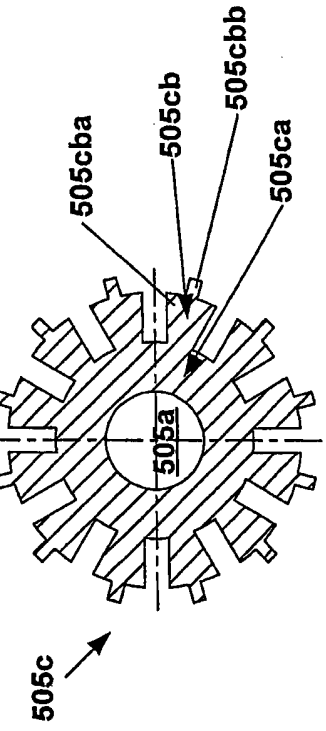
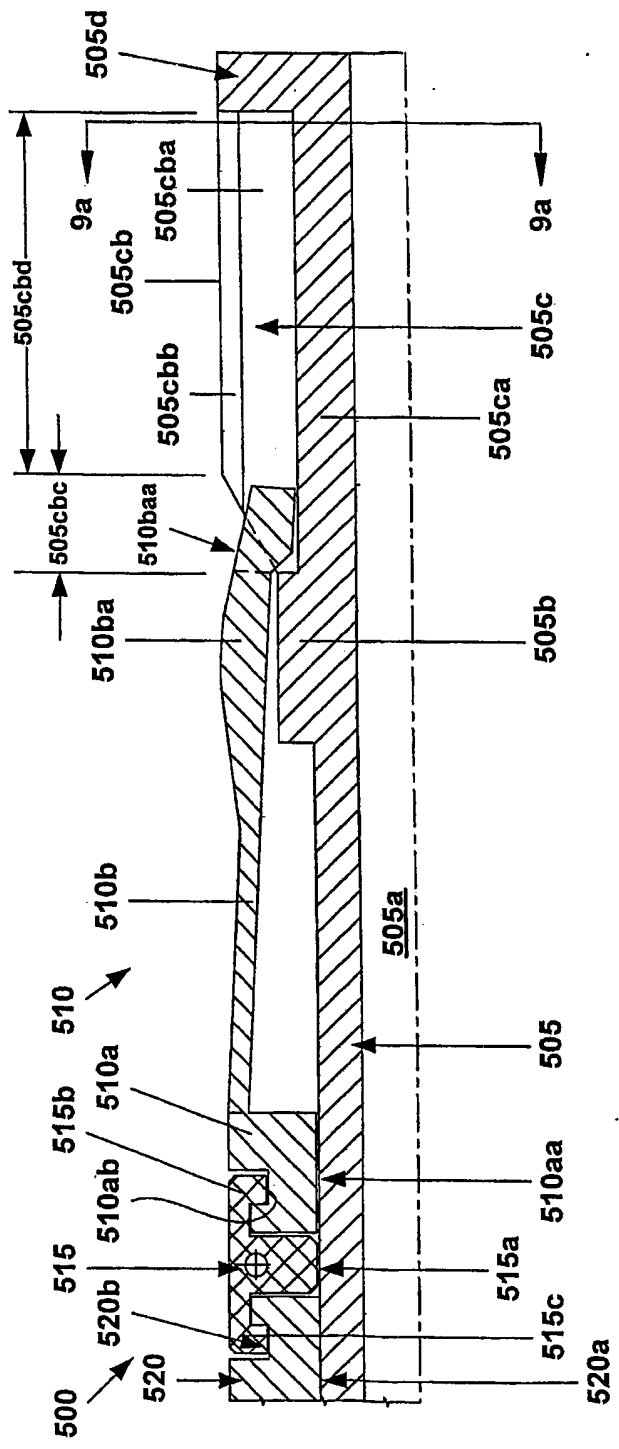

Fig. 9

Fig. 9a

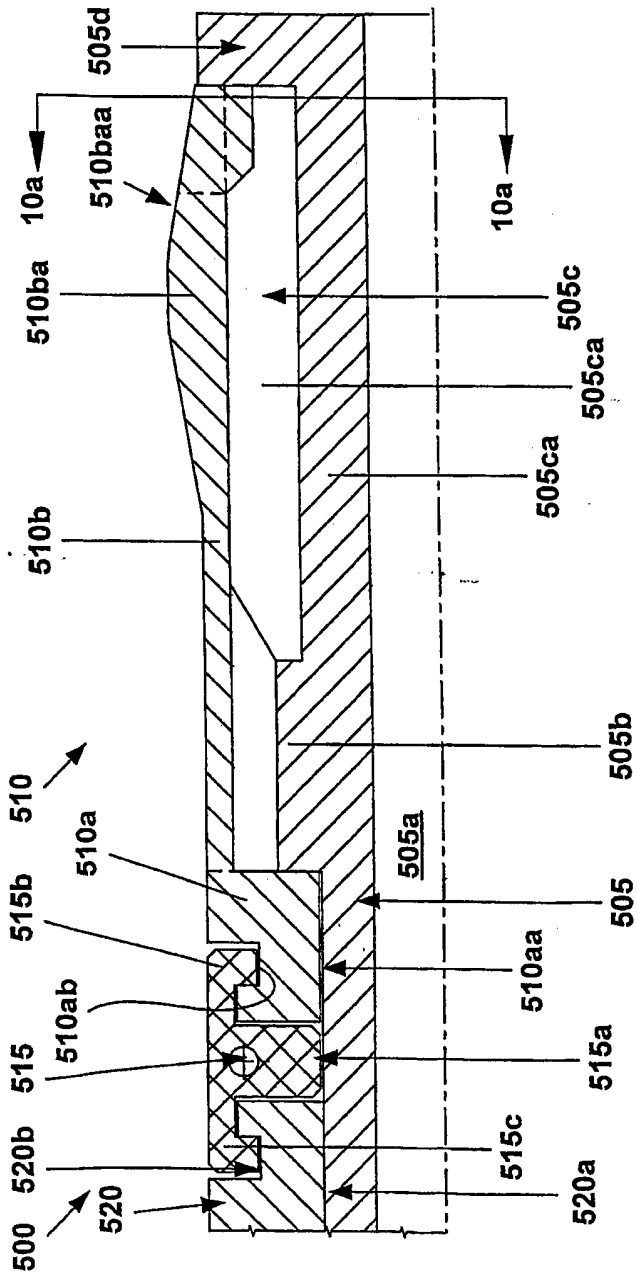

Fig. 10

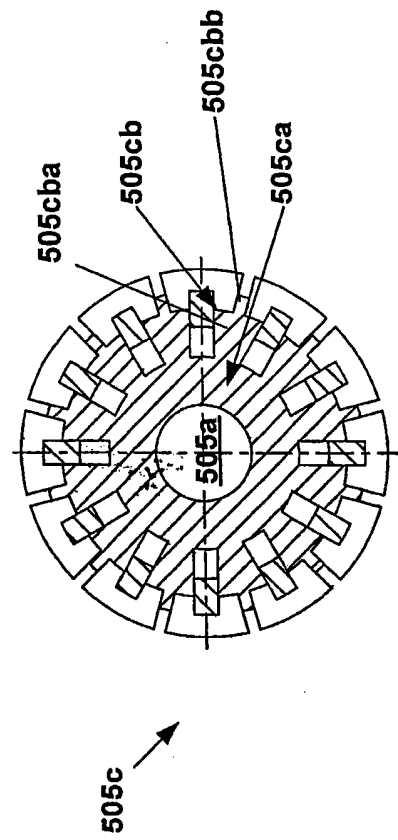

Fig. 10a

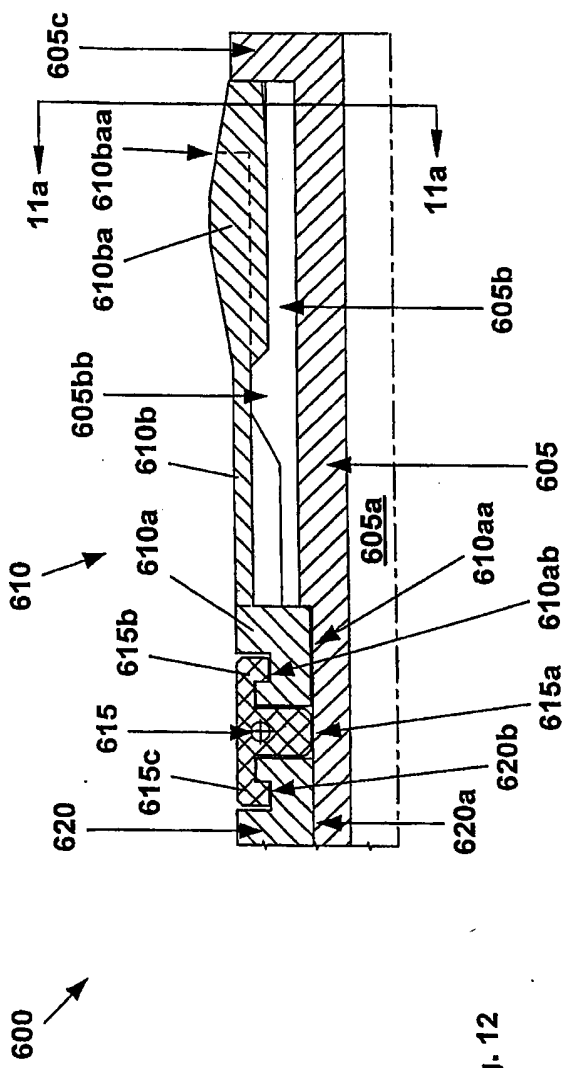

Fig. 12

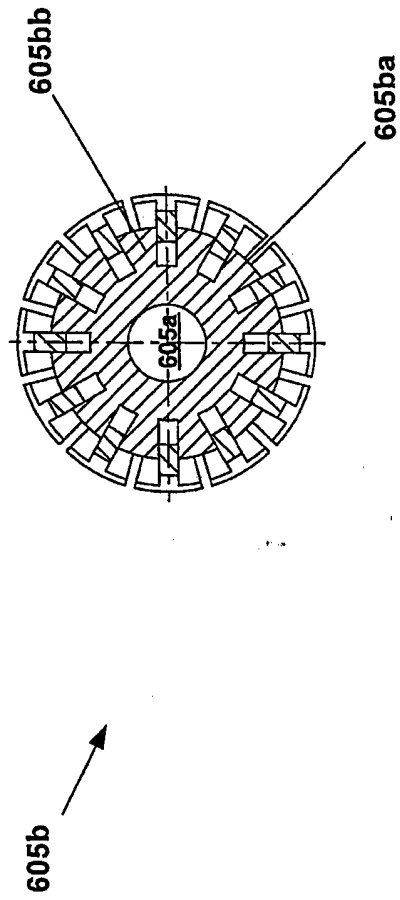

Fig. 12a

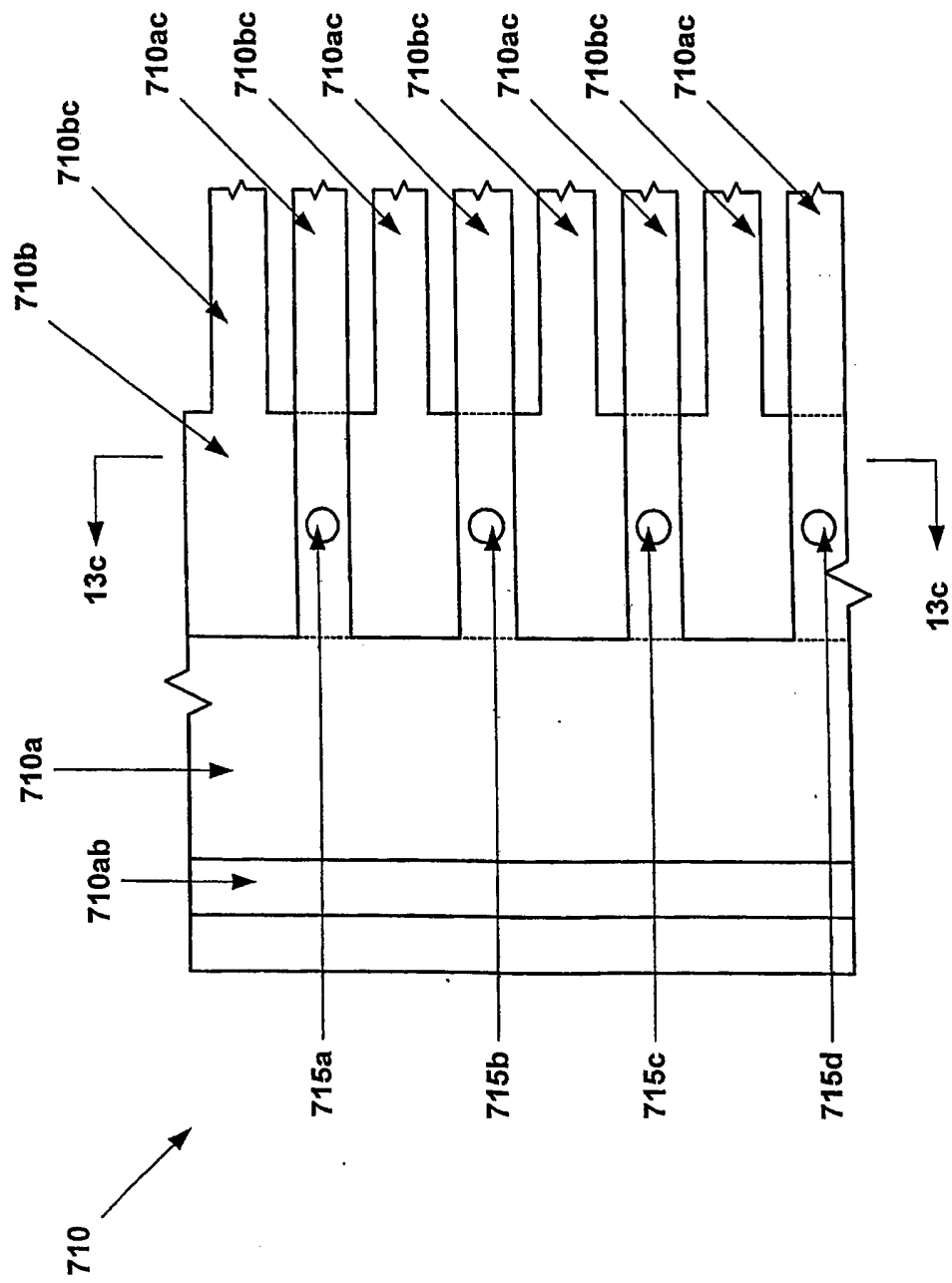

Fig. 13b

710 ↗

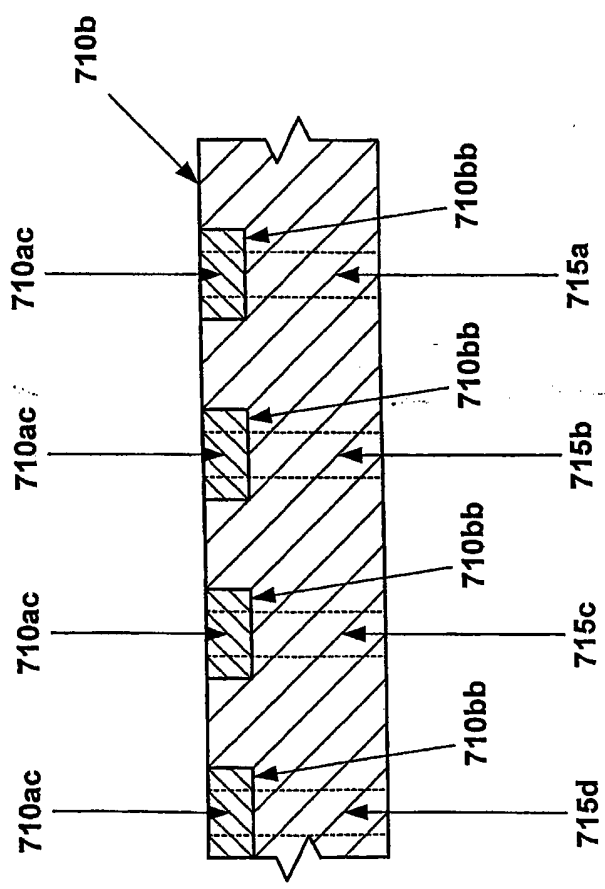

Fig. 13c

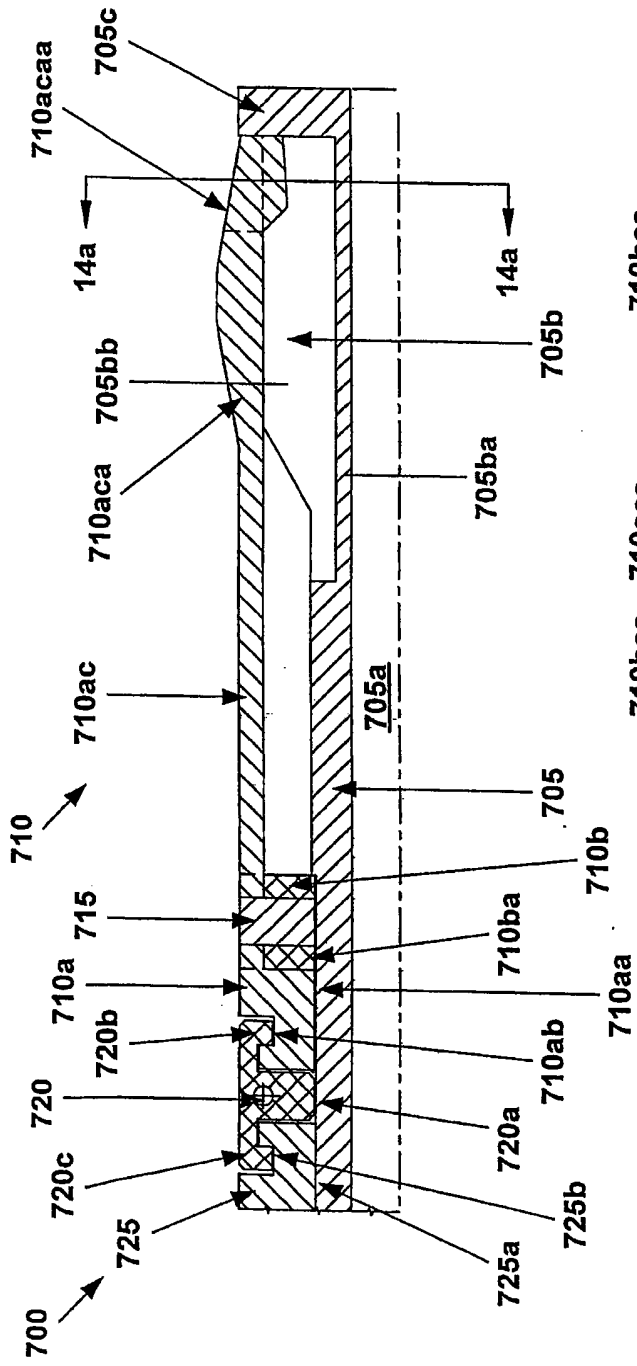

Fig. 14

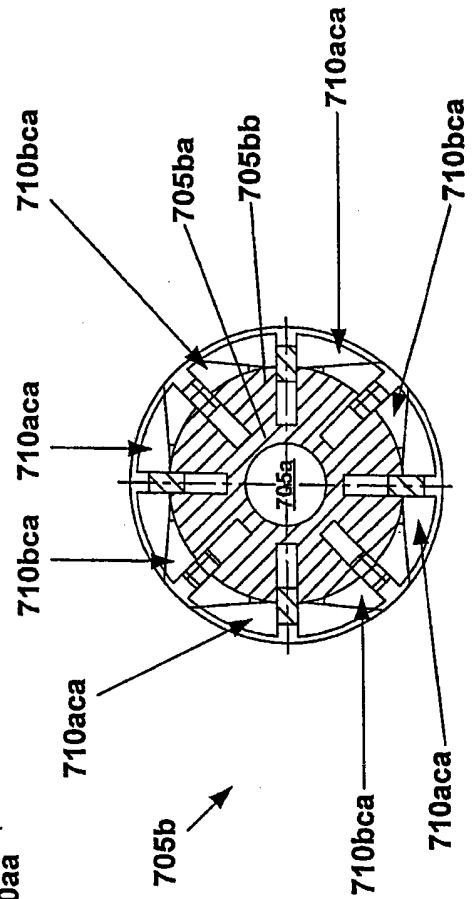

Fig. 14a

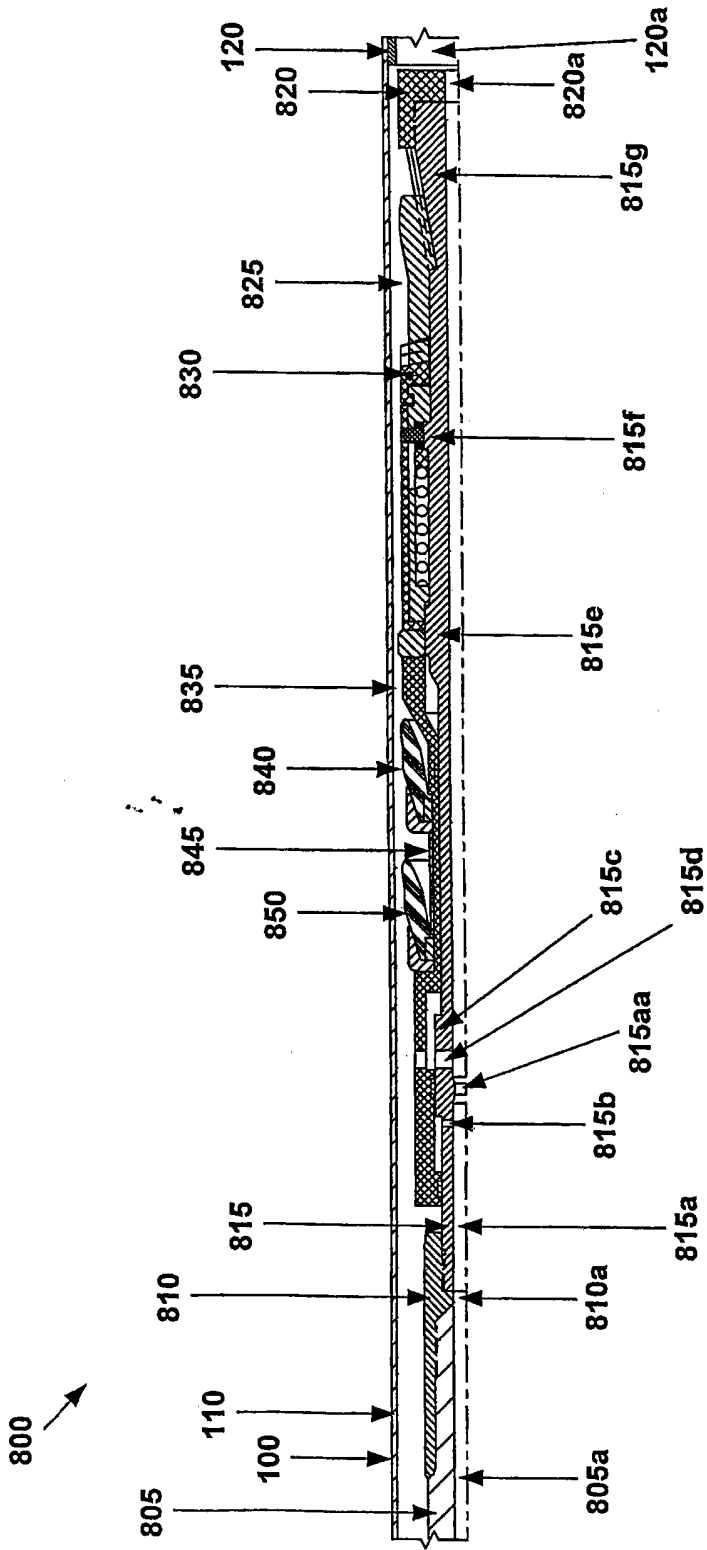

Fig. 15

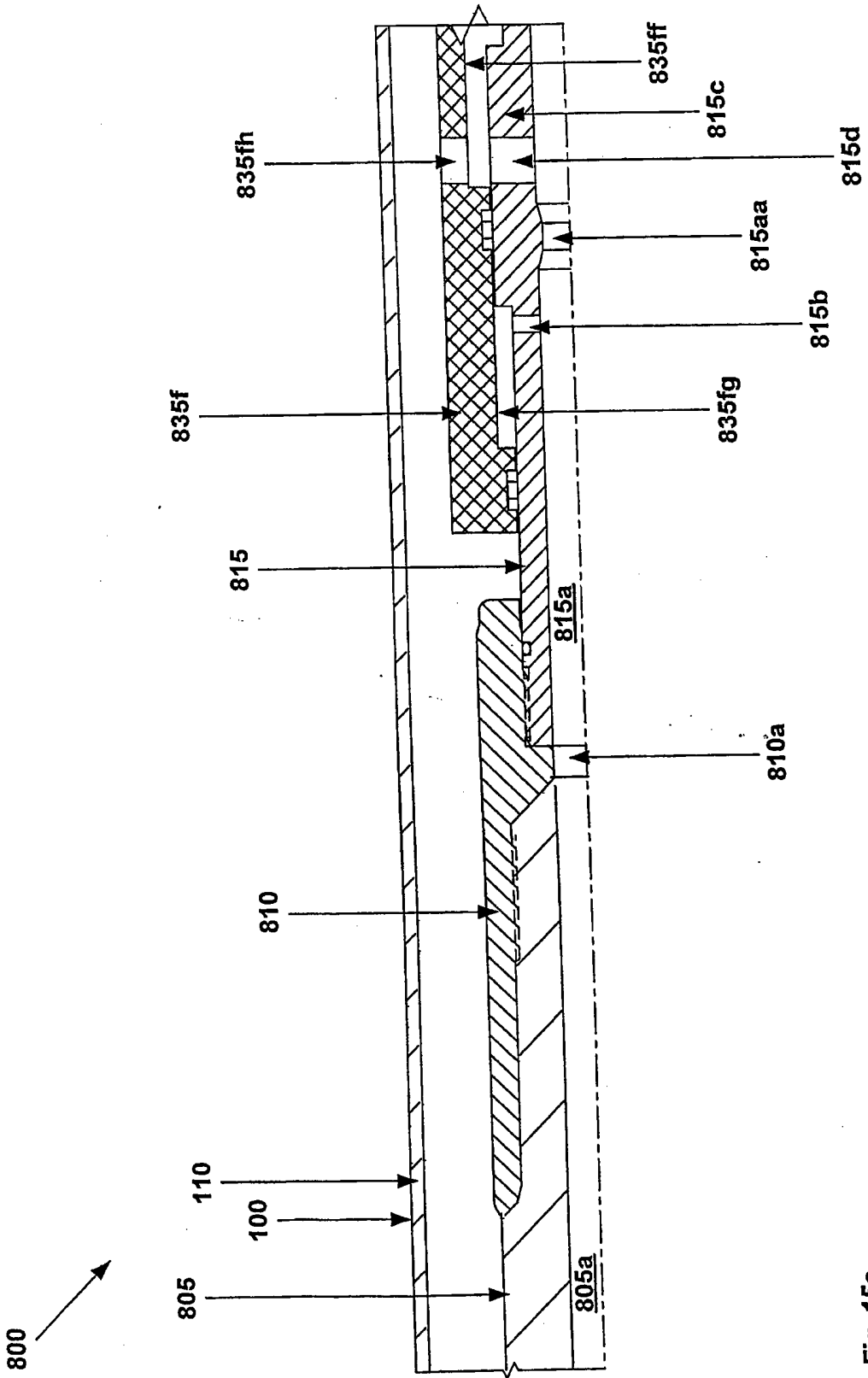

Fig. 15a

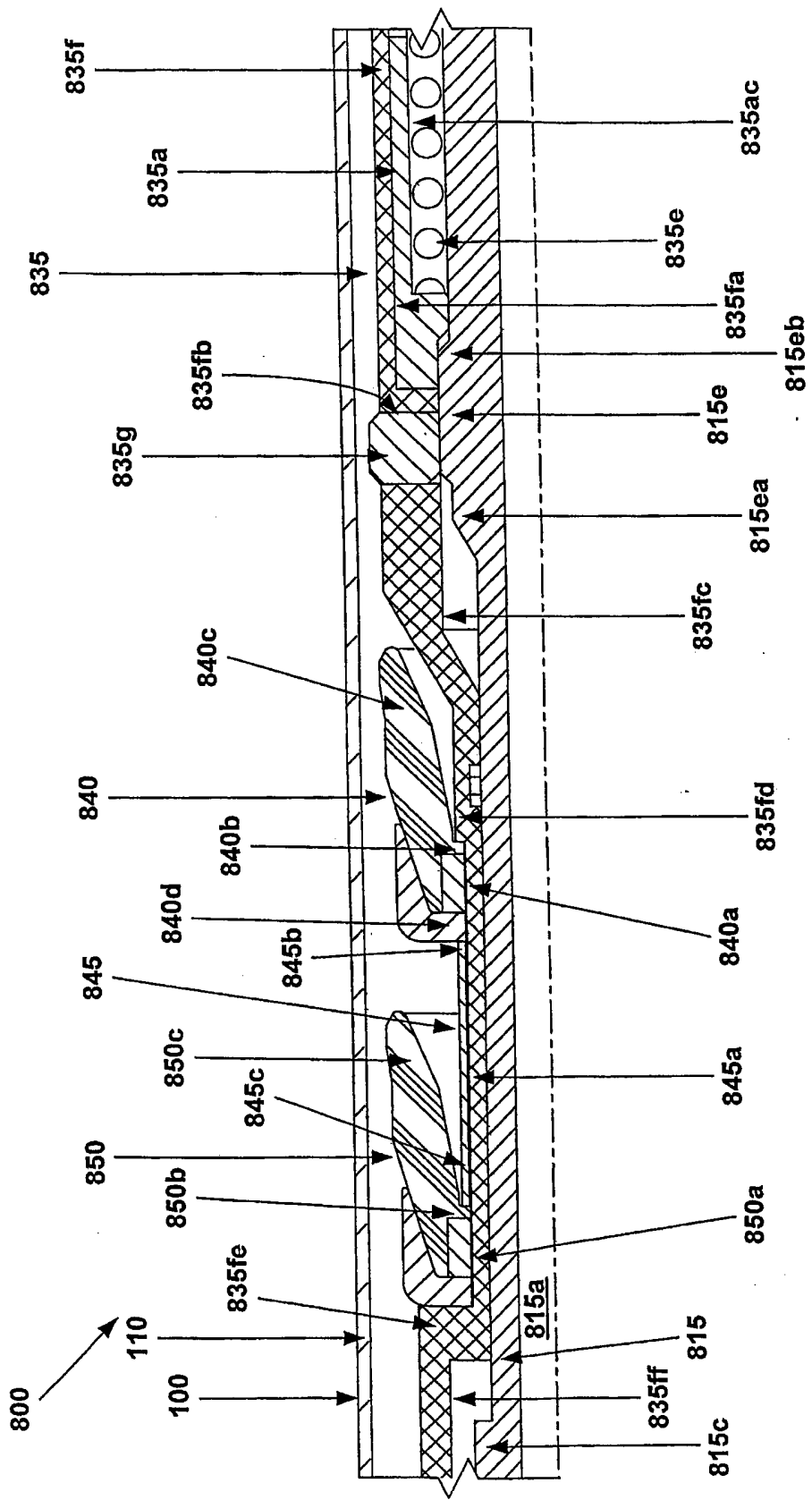

Fig. 15b

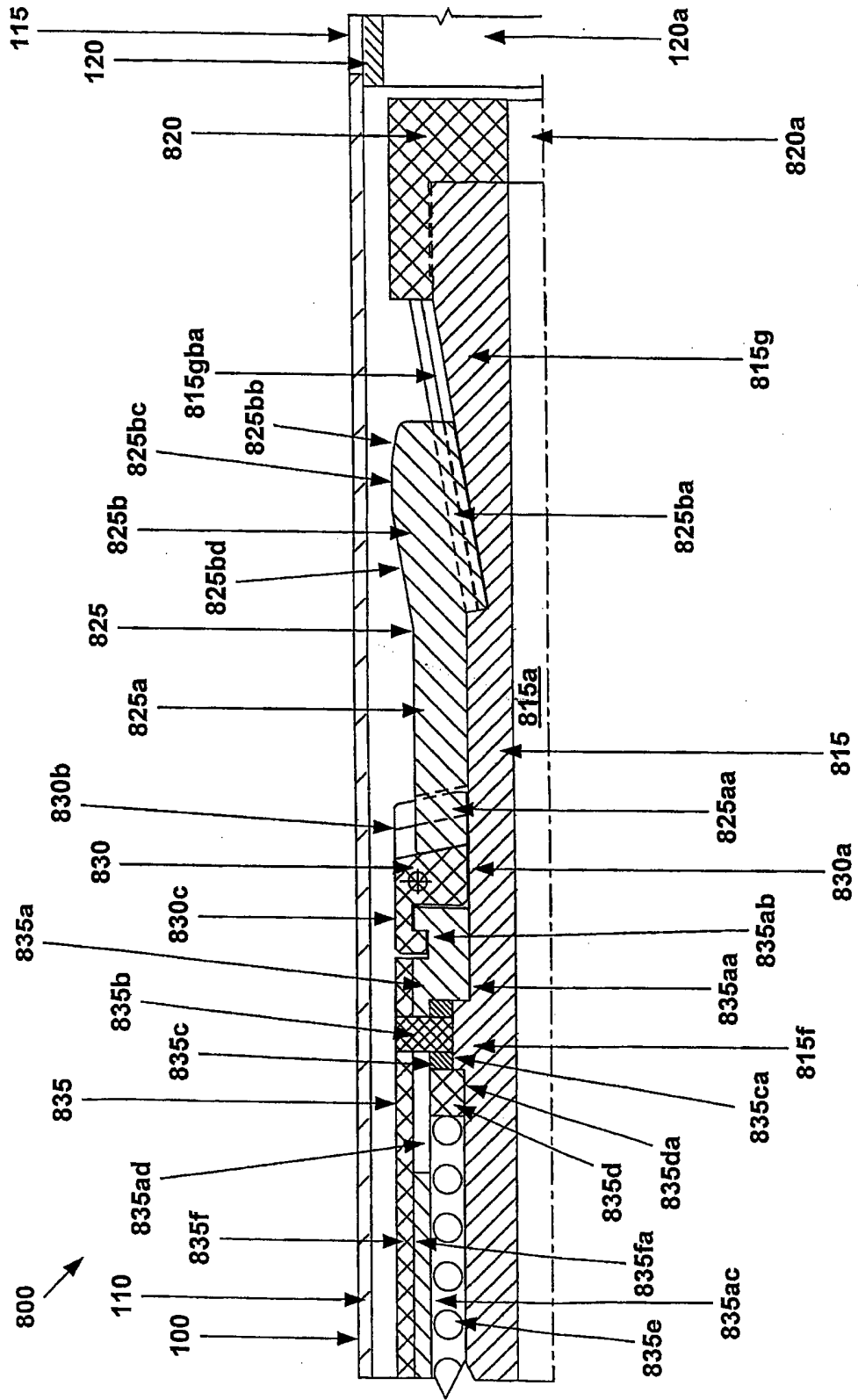

Fig. 15c

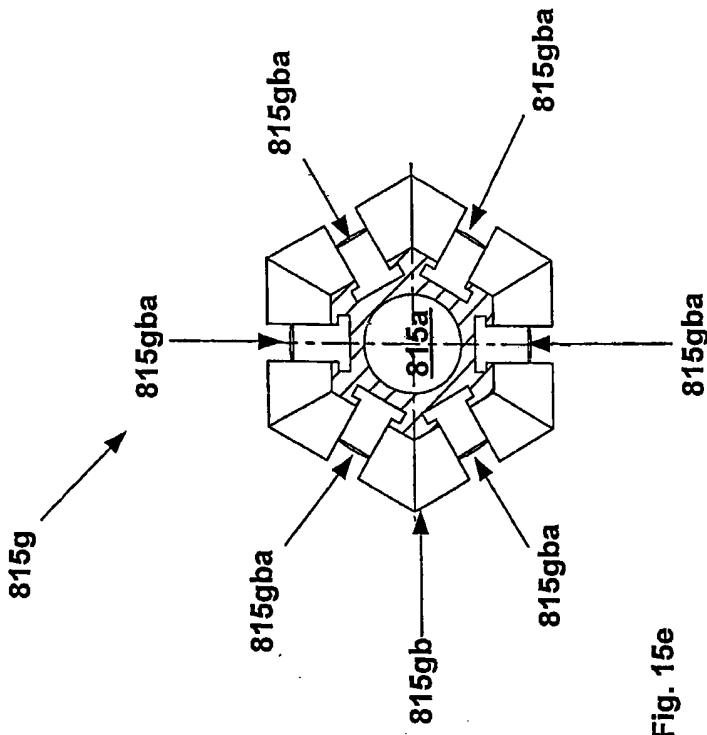

Fig. 15e

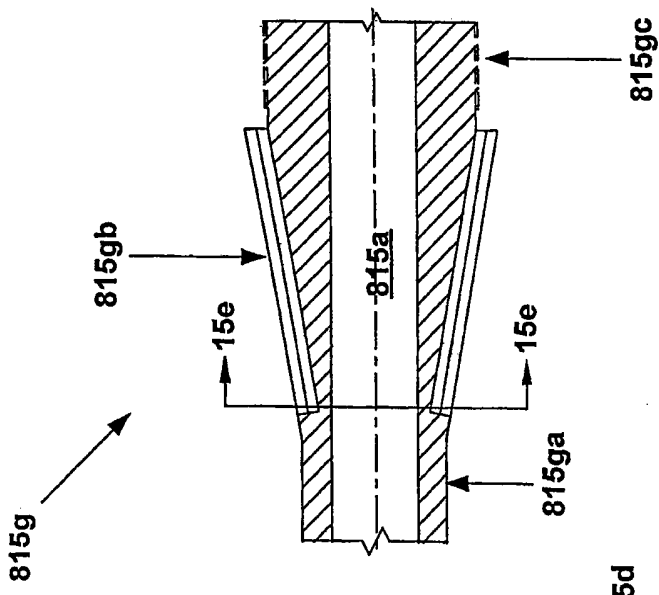

Fig. 15d

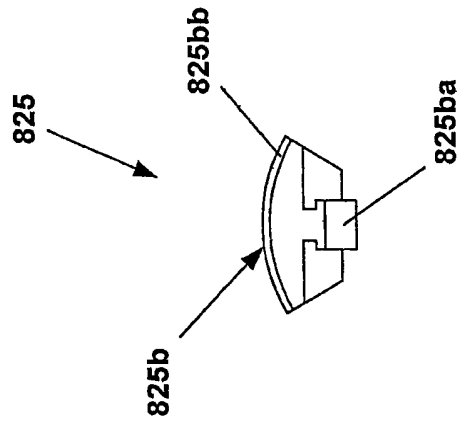

Fig. 15g

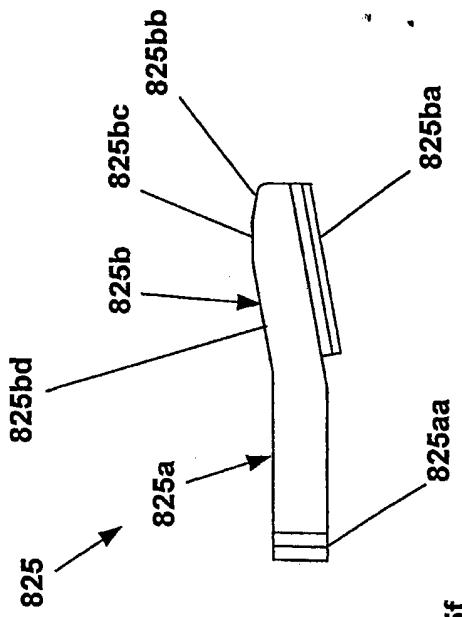

Fig. 15f

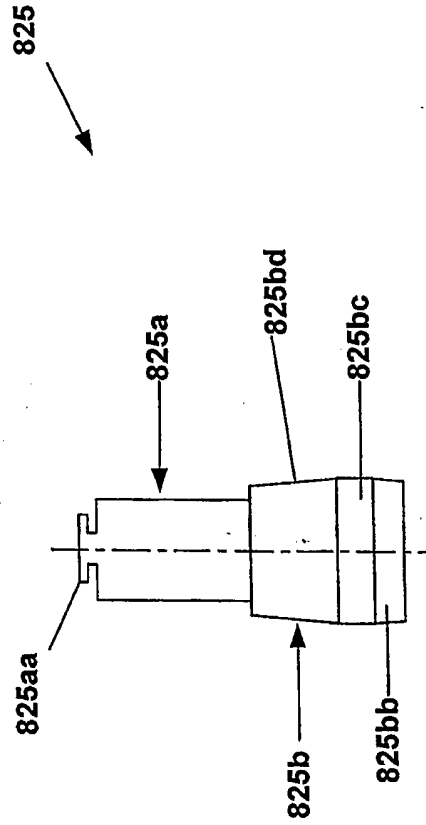

Fig. 15h

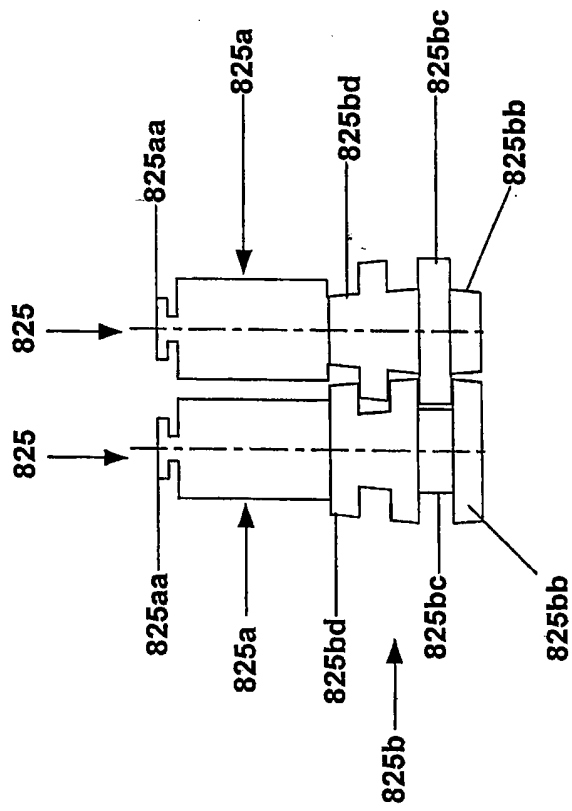

Fig. 15i

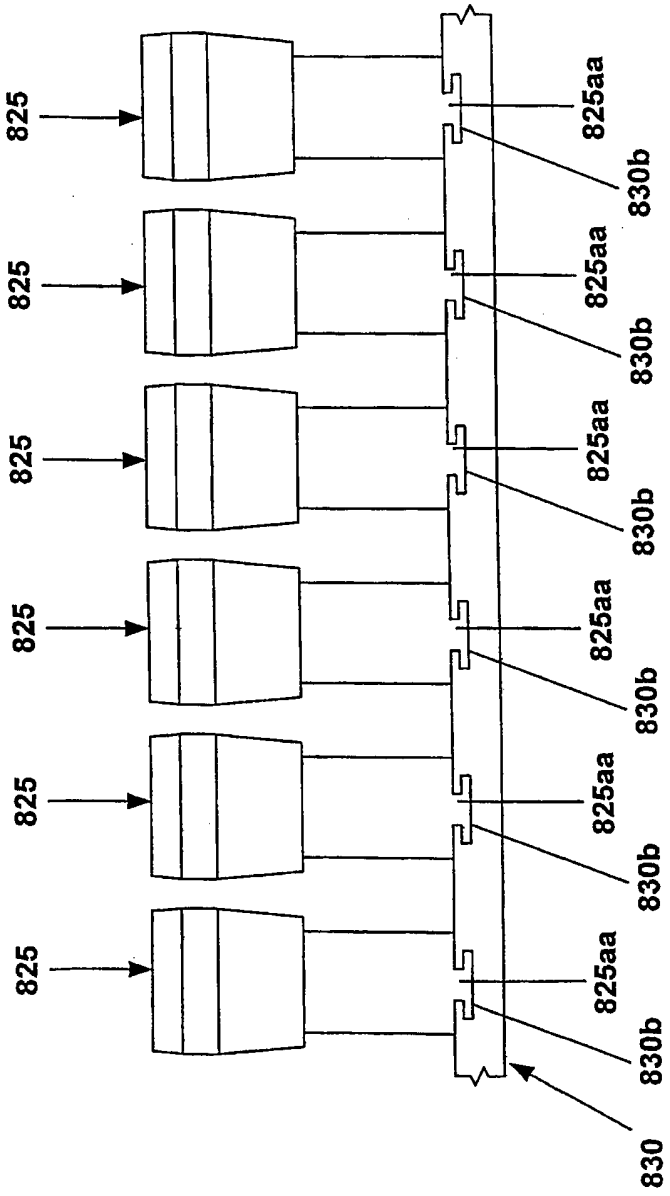

Fig. 15j

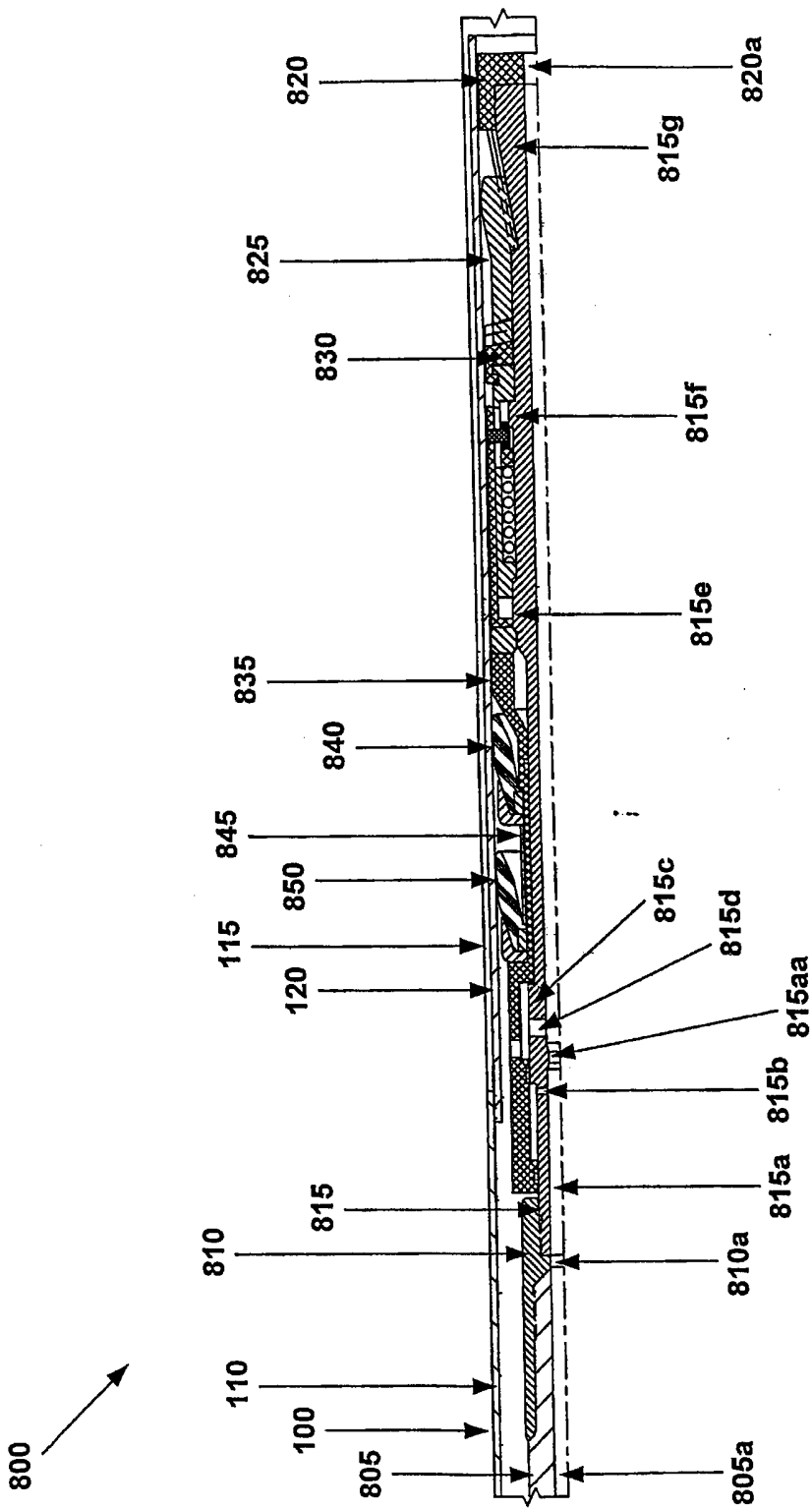

Fig. 16

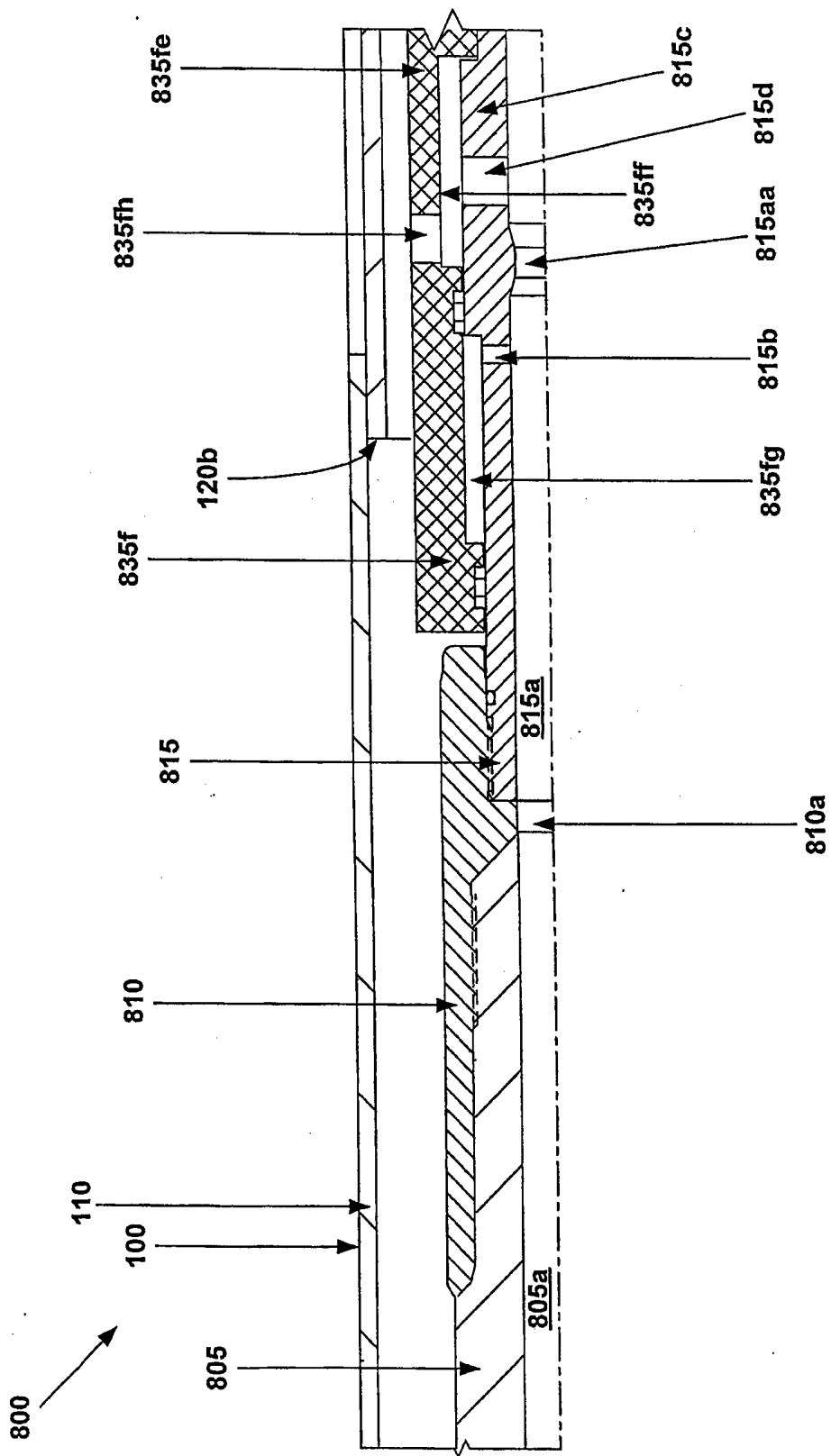

Fig. 16a

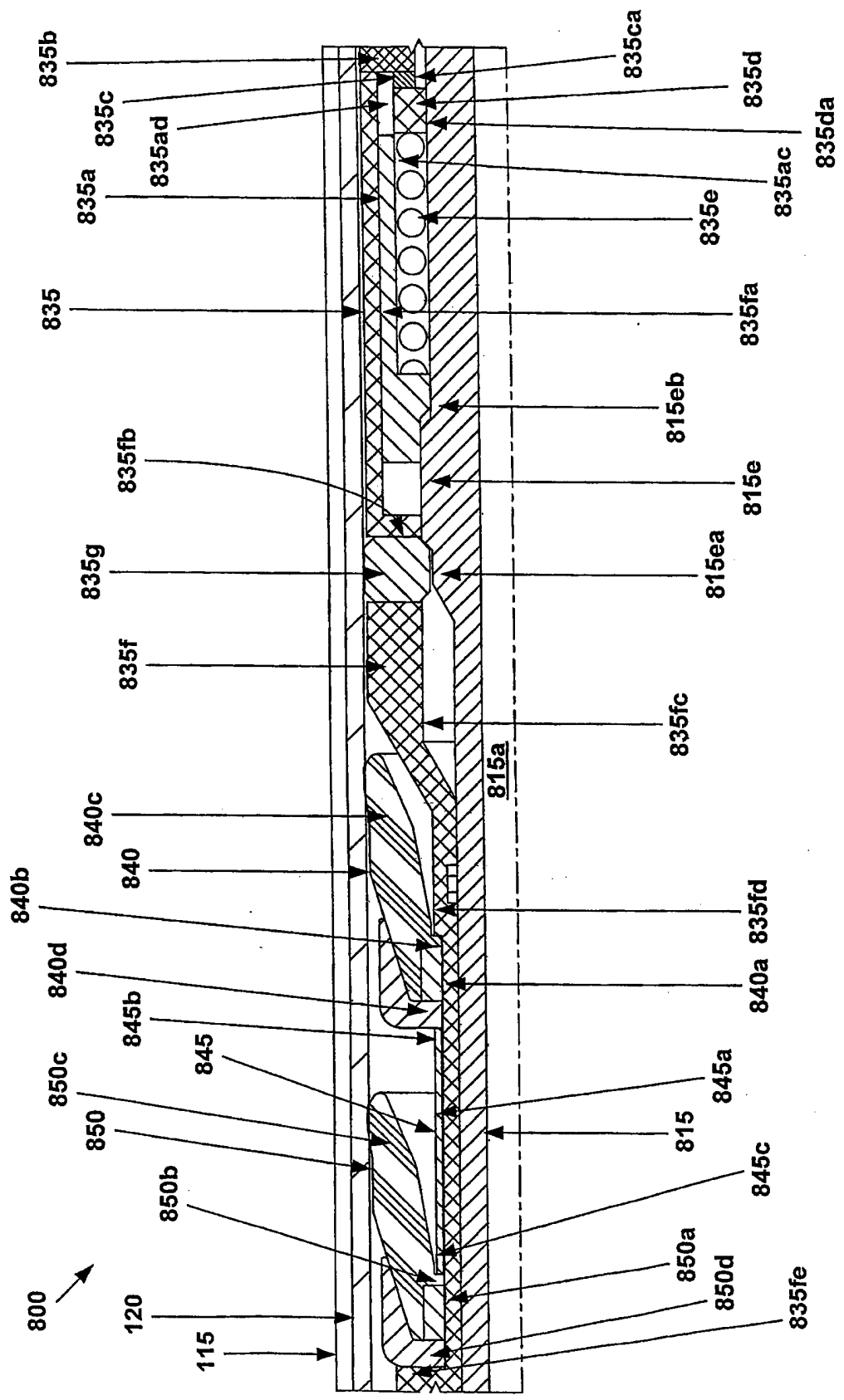

Fig. 16b

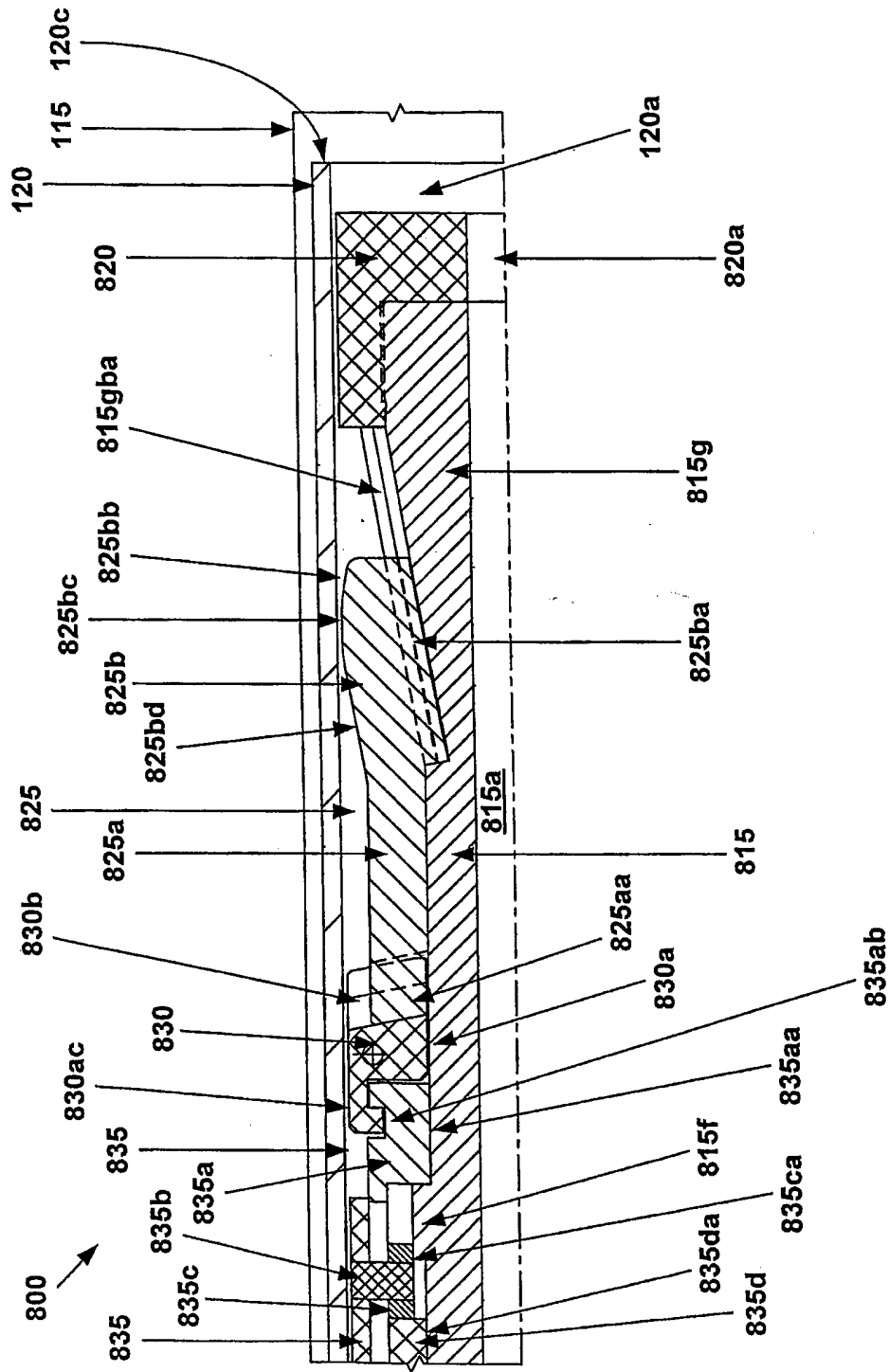

Fig. 16c

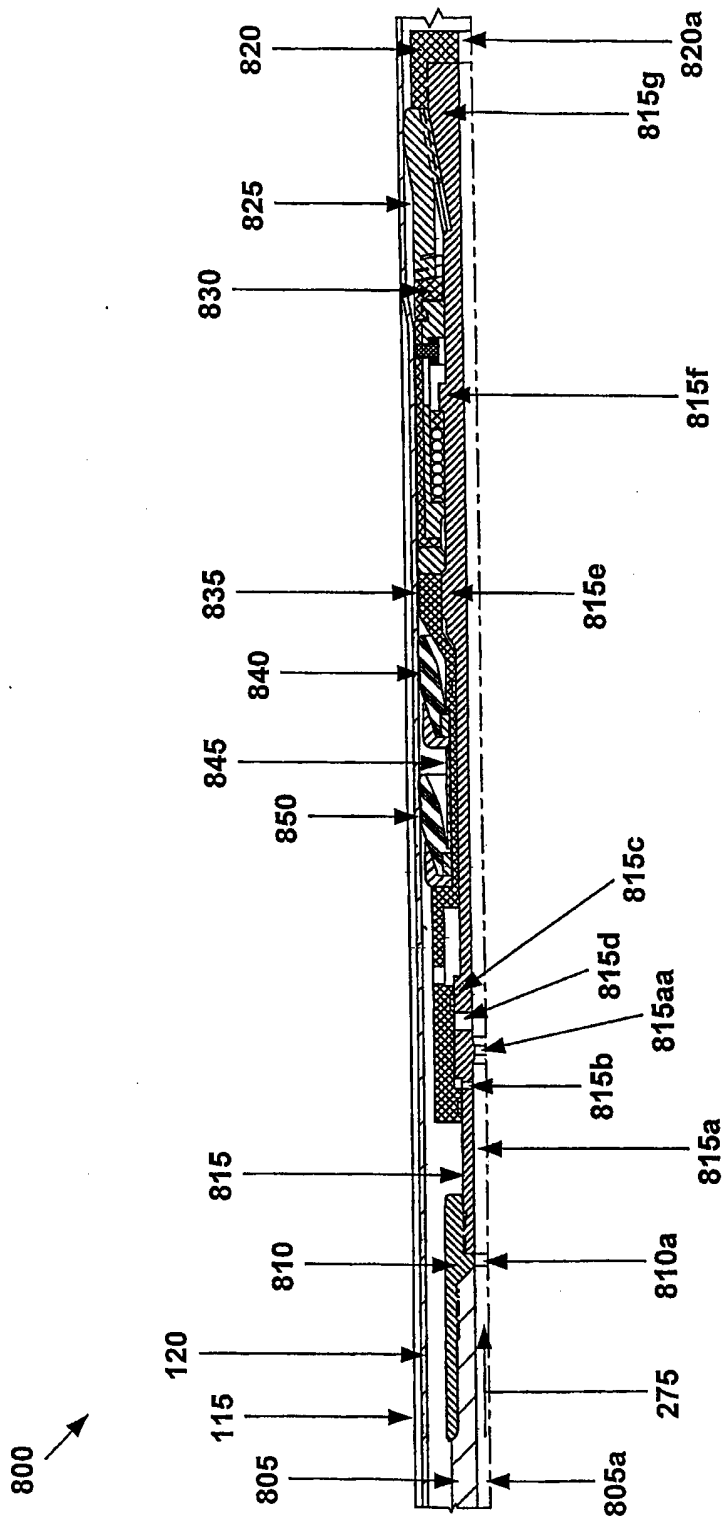

Fig. 17

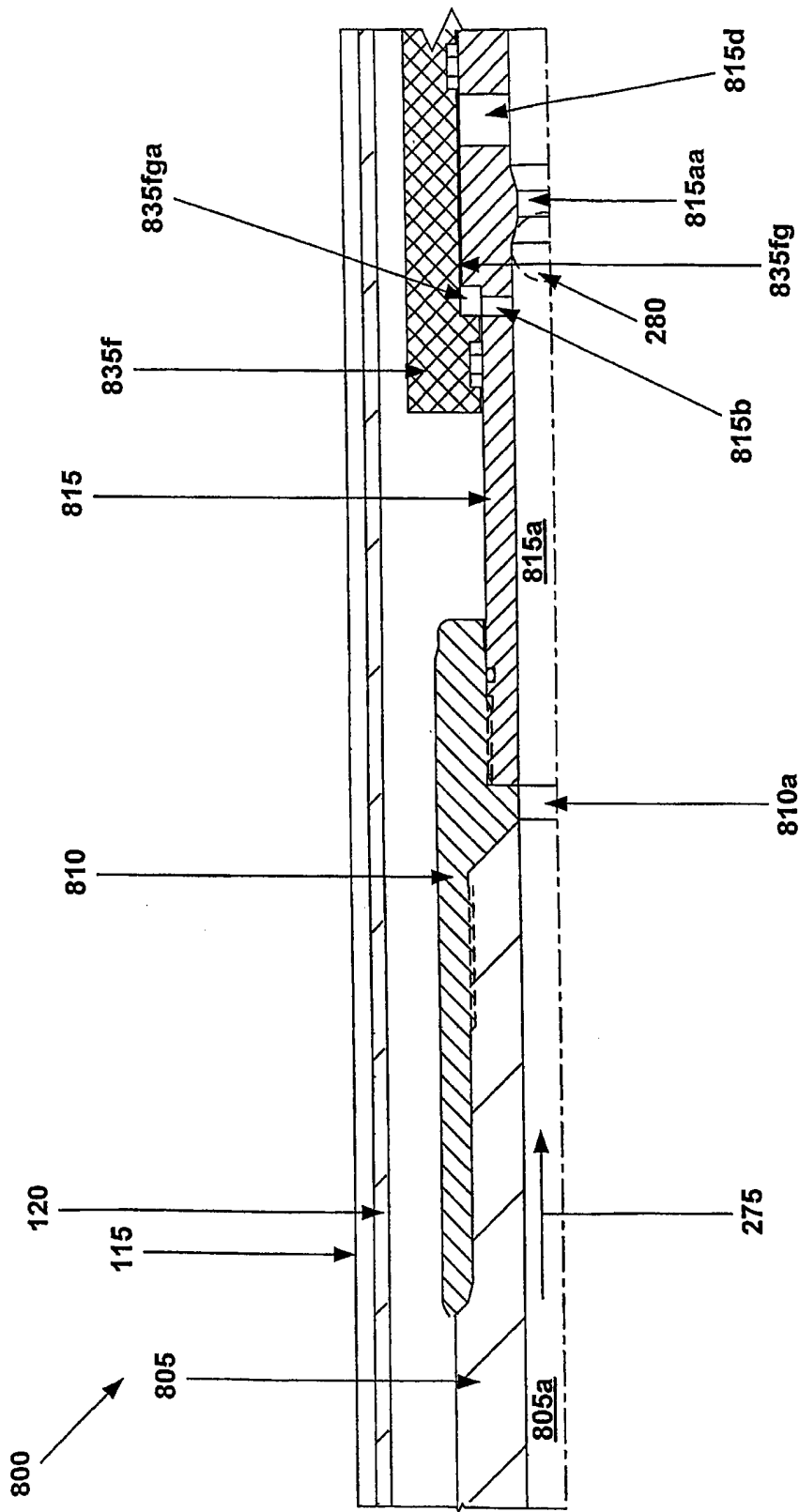

Fig. 17a

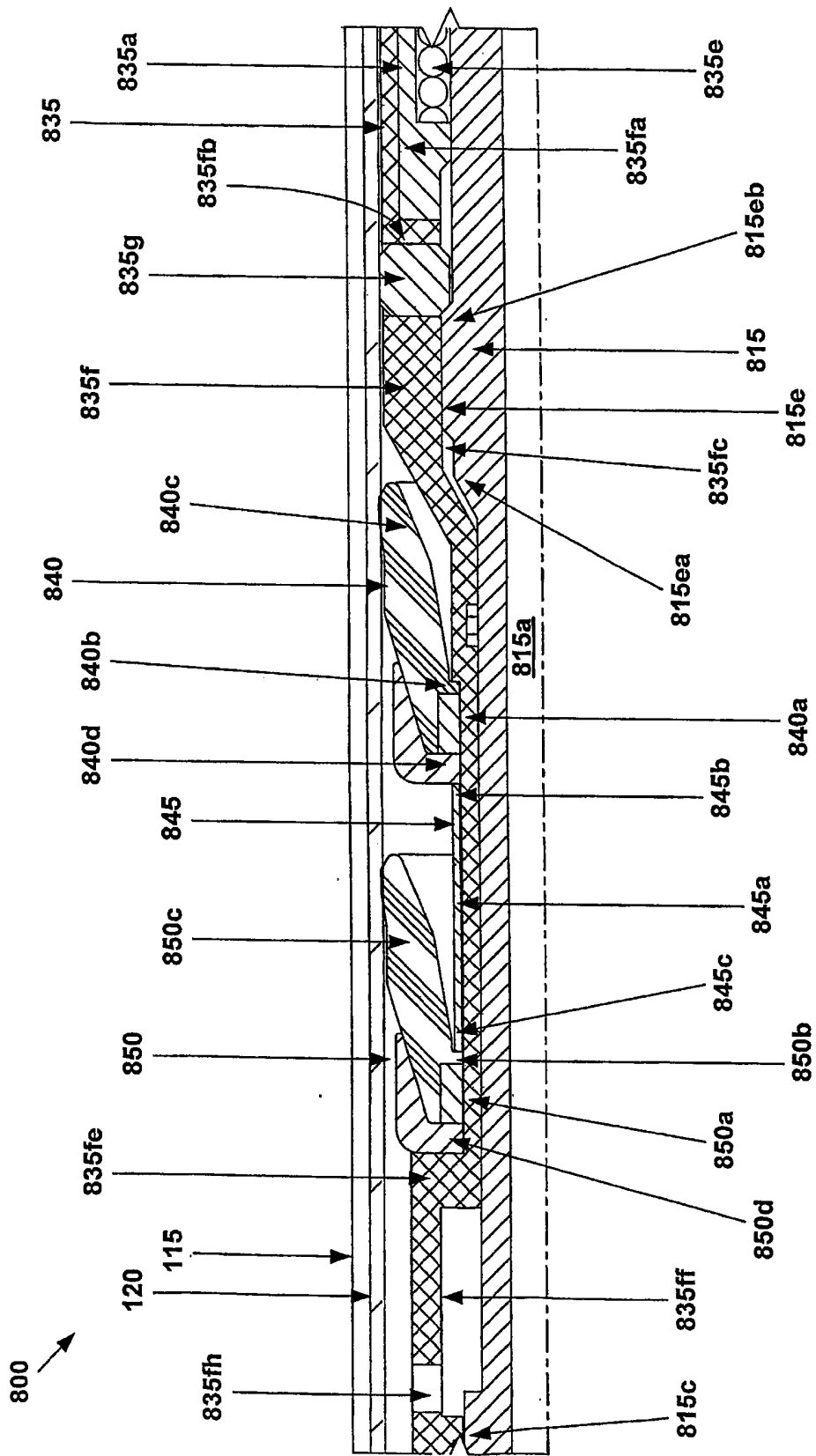

Fig. 17b

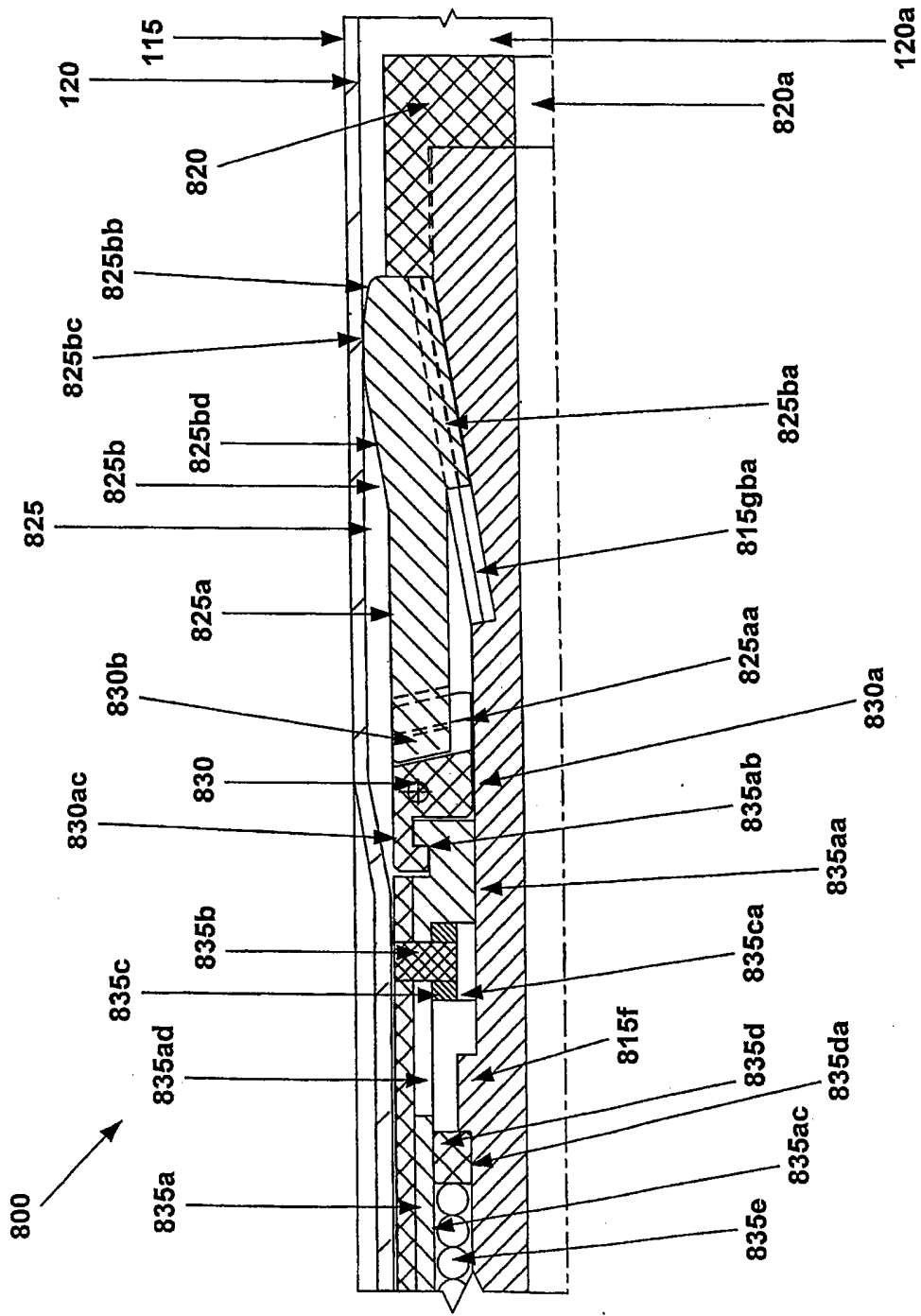

Fig. 17c

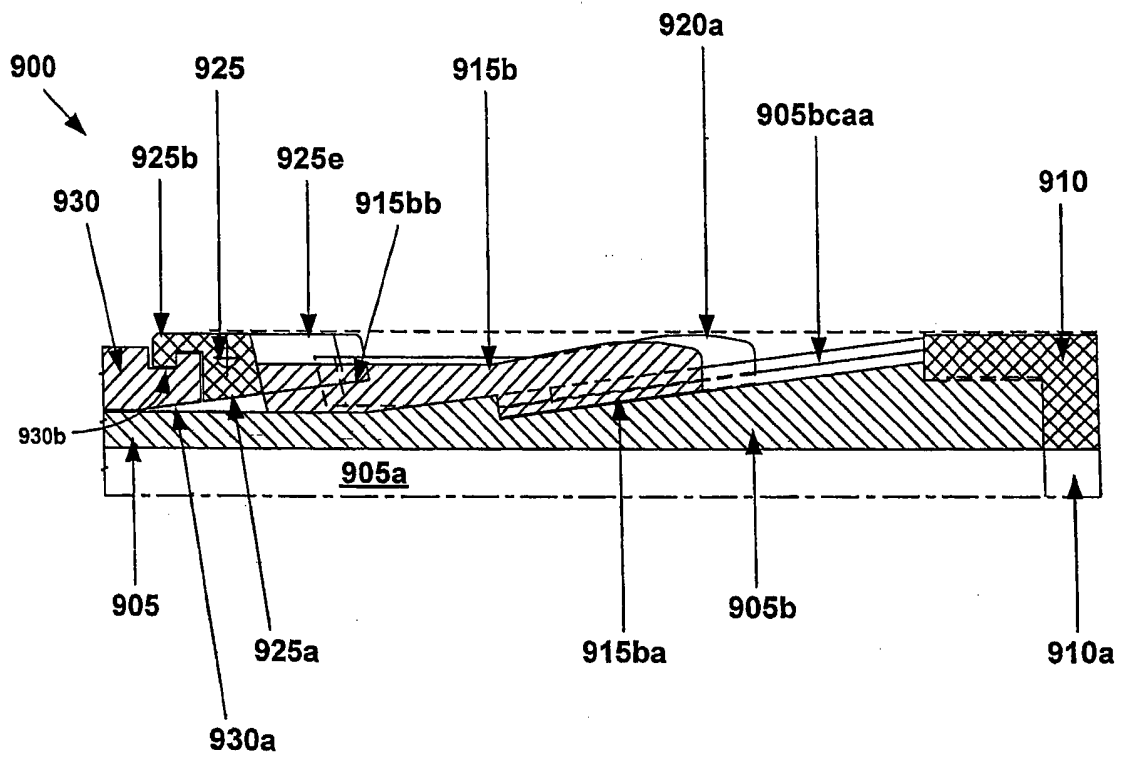

Fig. 18a

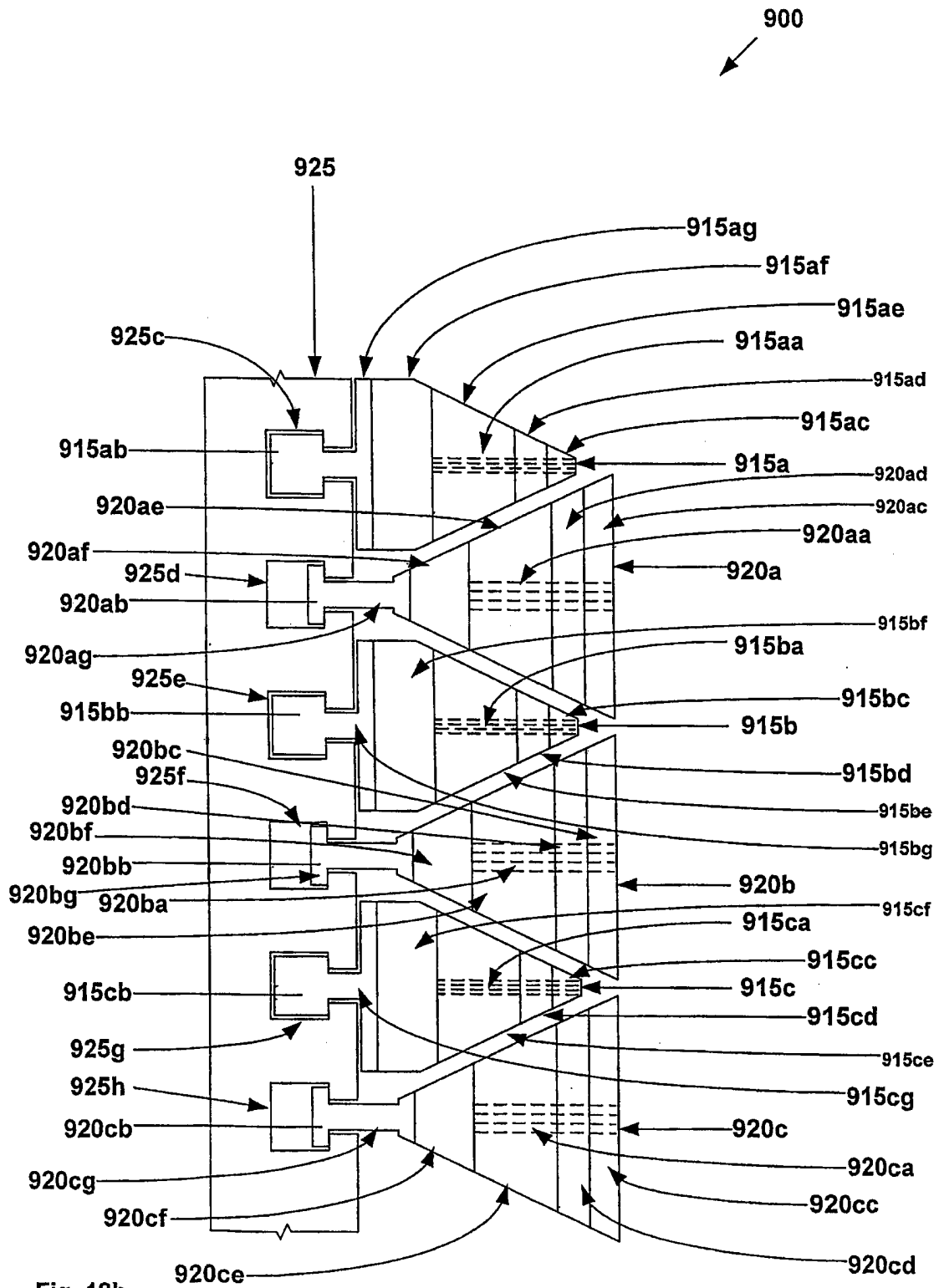

Fig. 18b

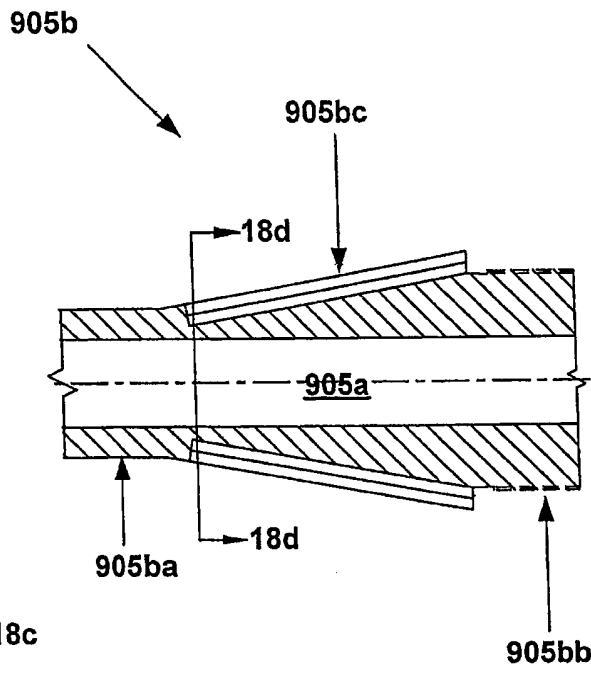

Fig. 18c

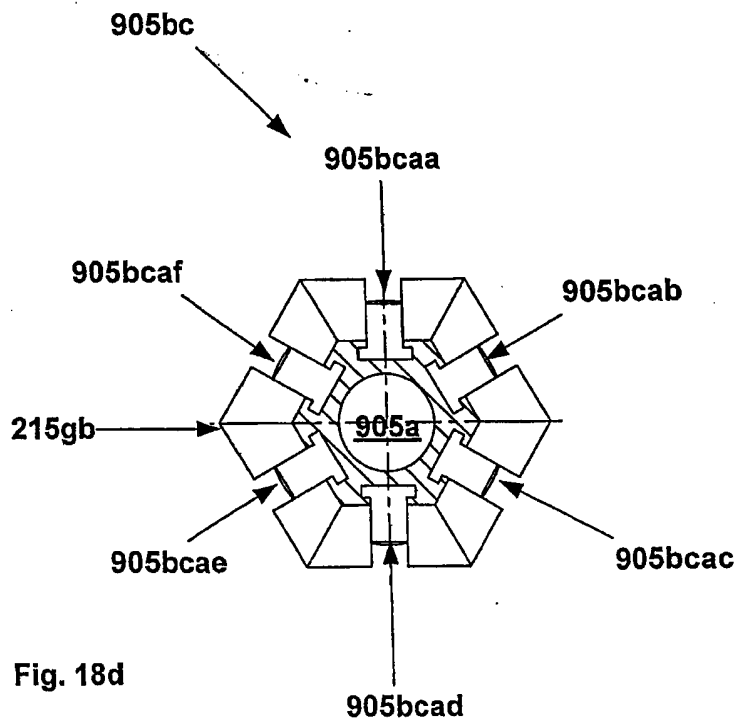

Fig. 18d

900

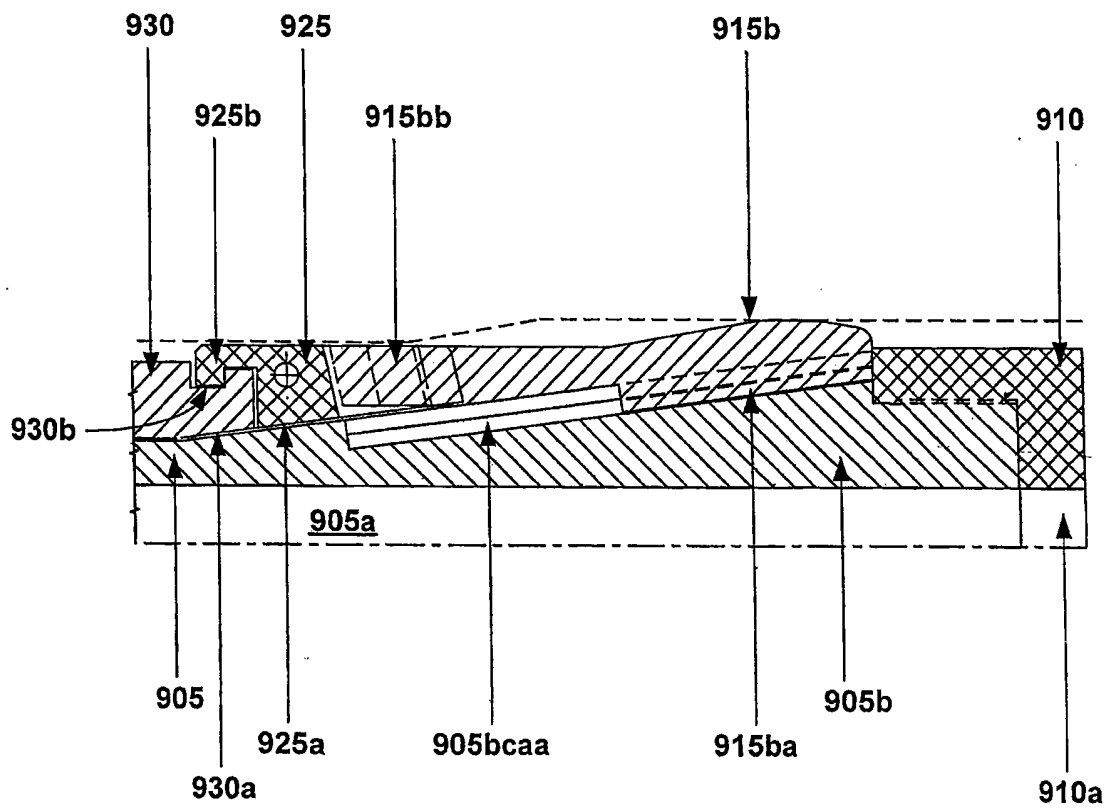

Fig. 19a

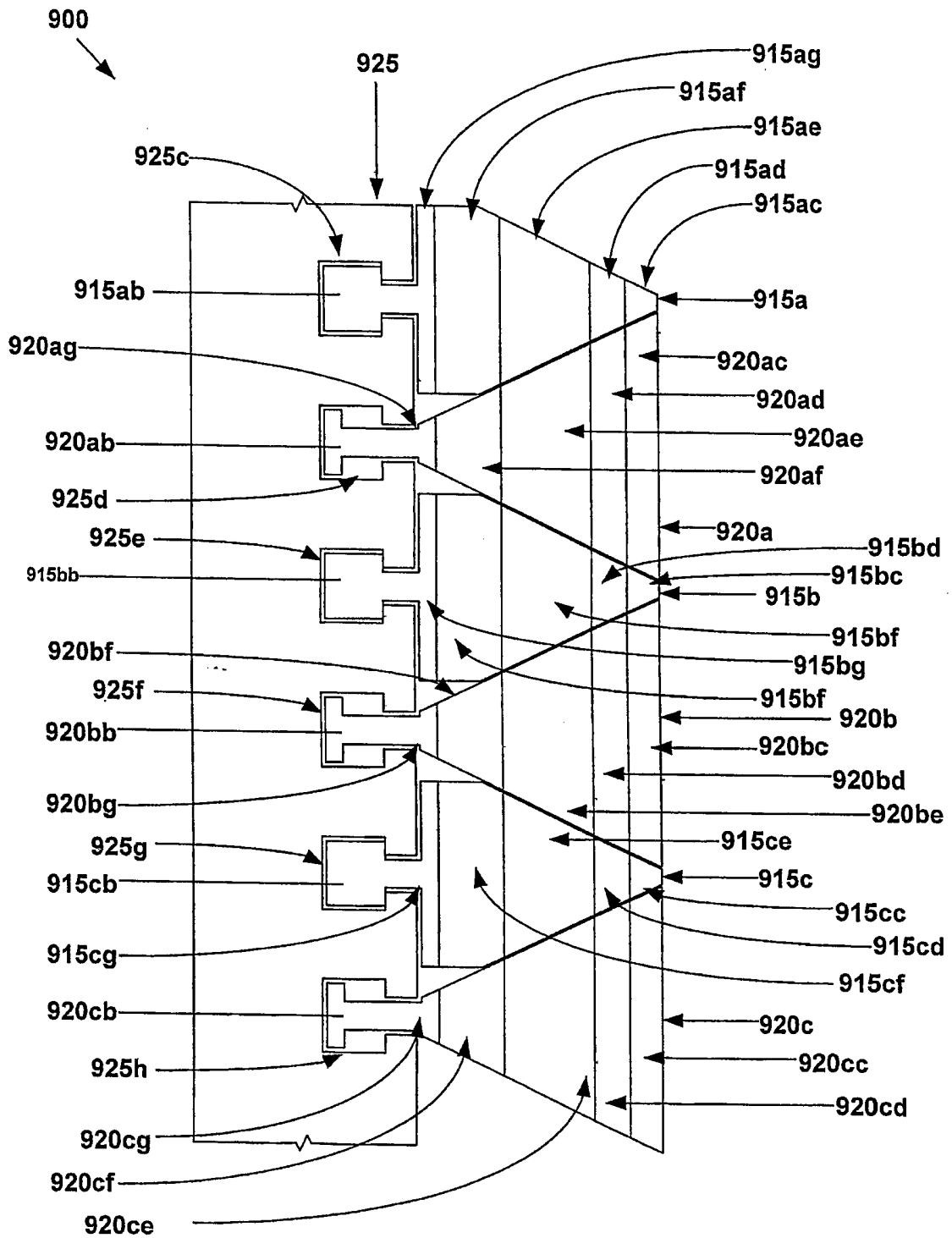

Fig. 19b

1000

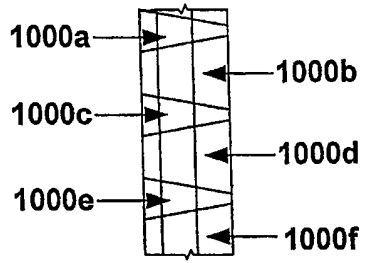

Fig. 20a

1100

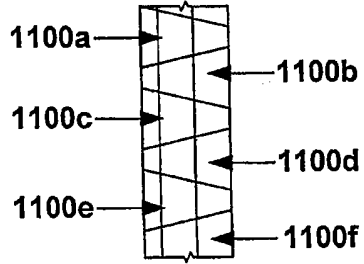

Fig. 20b

1200

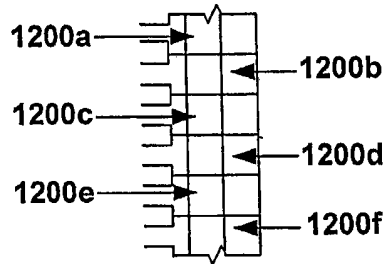

Fig. 20c

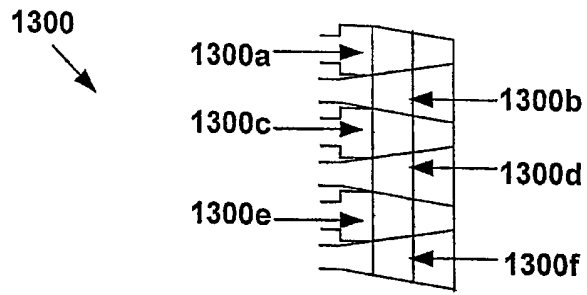

Fig. 20d

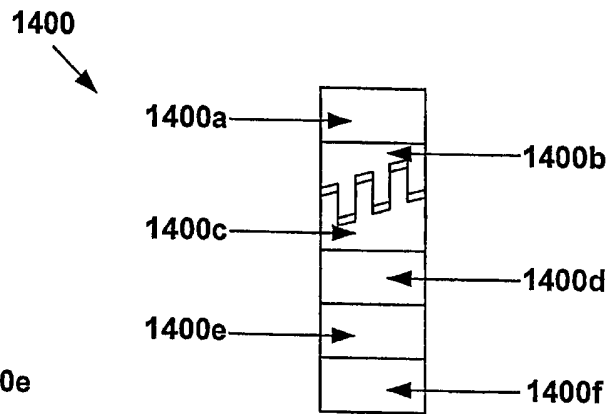

Fig. 20e

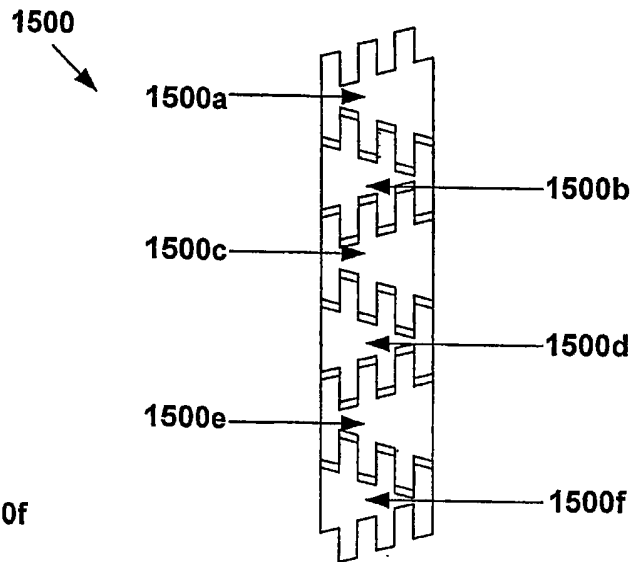

Fig. 20f

1600

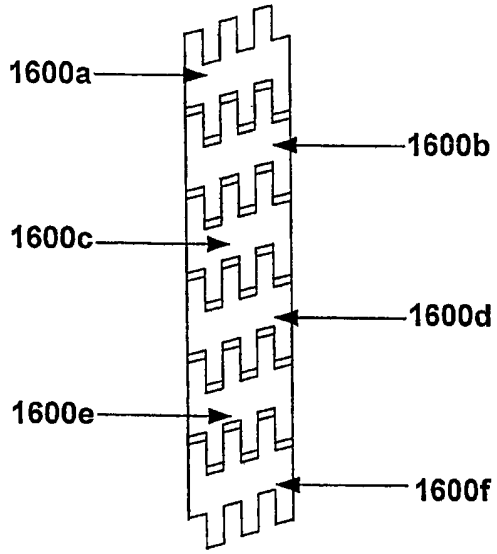

Fig. 20g

1700

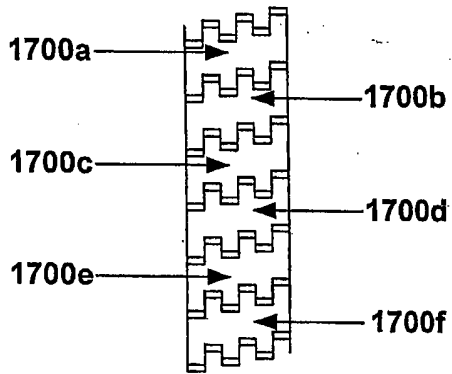

Fig. 20h

1800

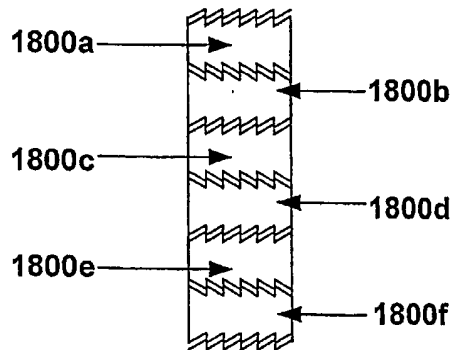

Fig. 20i

1900

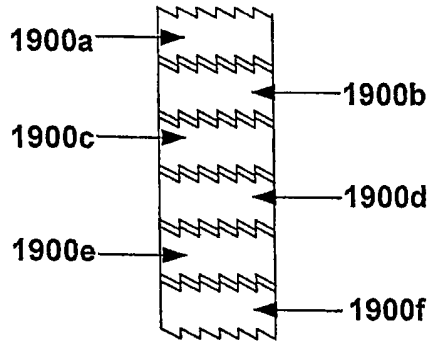

Fig. 20j

2000

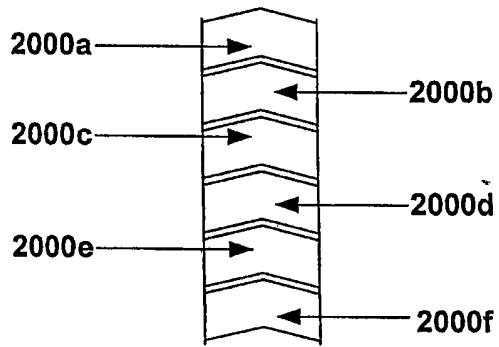

Fig. 20k

2100

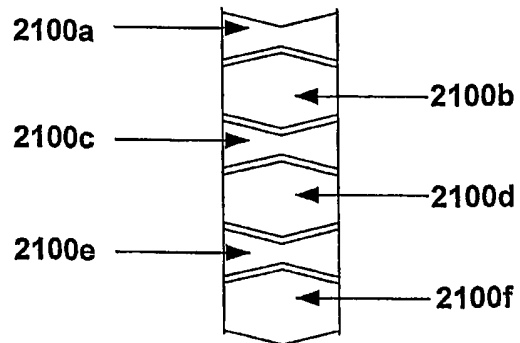

Fig. 20l

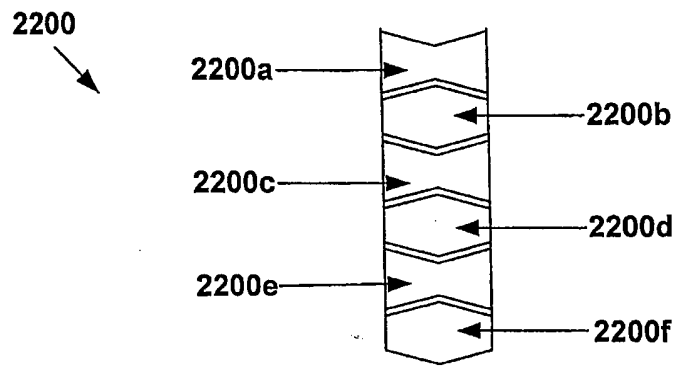

Fig. 20m

ADJUSTABLE EXPANSION CONE ASSEMBLY**Cross Reference To Related Applications**

This application claims the benefit of the filing date of U.S. provisional patent application serial no. 60/318,021, attorney docket no. 25791.58, filed on 9/7/2001, the disclosure of which is incorporated herein by reference.

This application is related to the following: (1) U.S. patent application serial no. 09/454,139, attorney docket no. 25791.03.02, filed on 12/3/1999, (2) U.S. patent application serial no. 09/510,913, attorney docket no. 25791.7.02, filed on 2/23/2000, (3) U.S. patent application serial no. 09/502,350, attorney docket no. 25791.8.02, filed on 2/10/2000, (4) U.S. patent application serial no. 09/440,338, attorney docket no. 25791.9.02, filed on 11/15/1999, (5) U.S. patent application serial no. 09/523,460, attorney docket no. 25791.11.02, filed on 3/10/2000, (6) U.S. patent application serial no. 09/512,895, attorney docket no. 25791.12.02, filed on 2/24/2000, (7) U.S. patent application serial no. 09/511,941, attorney docket no. 25791.16.02, filed on 2/24/2000, (8) U.S. patent application serial no. 09/588,946, attorney docket no. 25791.17.02, filed on 6/7/2000, (9) U.S. patent application serial no. 09/559,122, attorney docket no. 25791.23.02, filed on 4/26/2000, (10) PCT patent application serial no. PCT/US00/18635, attorney docket no. 25791.25.02, filed on 7/9/2000, (11) U.S. provisional patent application serial no. 60/162,671, attorney docket no. 25791.27, filed on 11/1/1999, (12) U.S. provisional patent application serial no. 60/154,047, attorney docket no. 25791.29, filed on 9/16/1999, (13) U.S. provisional patent application serial no. 60/159,082, attorney docket no. 25791.34, filed on 10/12/1999, (14) U.S. provisional patent application serial no. 60/159,039, attorney docket no. 25791.36, filed on 10/12/1999, (15) U.S. provisional patent application serial no. 60/159,033, attorney docket no. 25791.37, filed on 10/12/1999, (16) U.S. provisional patent application serial no. 60/212,359, attorney docket no. 25791.38, filed on 6/19/2000, (17) U.S. provisional patent application serial no. 60/165,228, attorney docket no. 25791.39, filed on 11/12/1999, (18) U.S. provisional patent application serial no. 60/221,443, attorney docket no. 25791.45, filed on 7/28/2000, (19) U.S. provisional patent application serial no. 60/221,645, attorney docket no. 25791.46, filed on 7/28/2000, (20) U.S. provisional patent application serial no. 60/233,638, attorney docket no. 25791.47, filed on 9/18/2000, (21) U.S. provisional patent application serial no. 60/237,334, attorney docket no. 25791.48, filed on 10/2/2000, (22) U.S. provisional patent application serial no. 60/270,007, attorney docket no. 25791.50, filed on 2/20/2001; and (23) U.S. provisional patent application serial no. 60/262,434, attorney docket no. 25791.51, filed on 1/17/2001, the disclosures of which are incorporated herein by reference.

Background of the Invention

This invention relates generally to wellbore casings, and in particular to wellbore casings that are formed using expandable tubing.

Conventionally, when a wellbore is created, a number of casings are installed in the borehole to prevent collapse of the borehole wall and to prevent undesired outflow of drilling fluid into the formation or inflow of fluid from the formation into the borehole. The borehole is drilled in intervals whereby a casing which is to be installed in a lower borehole interval is lowered through a previously installed casing of an upper borehole interval. As a consequence of this procedure the casing of the lower interval is of smaller diameter than the casing of the upper interval. Thus, the casings are in a nested arrangement with casing diameters decreasing in downward direction. Cement annuli are provided between the outer surfaces of the casings and the borehole wall to seal the casings from the borehole wall. As a consequence of this nested arrangement a relatively large borehole diameter is required at the upper part of the wellbore. Such a large borehole diameter involves increased costs due to heavy casing handling equipment, large drill bits and increased volumes of drilling fluid and drill cuttings. Moreover, increased drilling rig time is involved due to required cement pumping, cement hardening, required equipment changes due to large variations in hole diameters drilled in the course of the well, and the large volume of cuttings drilled and removed.

The present invention is directed to overcoming one or more of the limitations of the existing procedures for forming new sections of casing in a wellbore.

Summary of the Invention

According to one aspect of the present invention, an apparatus for radially expanding a tubular member is provided that includes a tubular support member that includes a first tubular support body defining a longitudinal passage, a first lug coupled to and extending from the first tubular support body in the radial direction, a second lug coupled to and extending from the first tubular support body in the radial direction, and an expansion cone support body coupled to the first tubular support body. The expansion cone support body includes an N-sided tapered tubular support member, wherein each side of the multi-sided tapered tubular support member defines a T-shaped slot. N expansion cone segments are movably coupled to the expansion cone support body, each including an expansion cone segment body including arcuate conical outer surfaces, a first T-shaped retaining member coupled to the expansion cone segment body for movably coupling the expansion cone segment body to a corresponding one of the T-shaped slots of the expansion cone support body, and a

second T-shaped retaining member coupled to the expansion cone segment body. A split ring collar assembly is movably coupled to the exterior of the tubular support member that includes a second tubular support body defining N T-shaped slots for movably receiving corresponding ones of the second T-shaped retaining members of the expansion cone segments, and an L-shaped retaining member coupled to the second tubular support body. A first drag block assembly is movably coupled to the tubular support member that includes a first drag block body defining a slot for receiving and mating with the L-shaped retaining member of the split ring collar, and a first J-shaped slot for receiving the first lug, and one or more first drag blocks coupled to the first drag block body. A second drag block assembly is movably coupled to the tubular support member that includes a second drag block body defining a second J-shaped slot for receiving the second lug, and one or more second drag blocks coupled to the second drag block body. First and second packer cups are coupled to the tubular support member between the first and second drag block assemblies.

According to another aspect of the present invention, an apparatus for radially expanding a tubular member is provided that includes a tubular support member that includes a first tubular support body defining a longitudinal passage, a first flange coupled to the first tubular support body, a second flange coupled to the first tubular support body, a first tapered flange coupled to the first tubular support body, a second tapered flange coupled to the first tubular support body, and an expansion cone support body coupled to the first tubular support body. The expansion cone support body includes an N-sided tapered tubular support member, wherein each side of the multi-sided tapered tubular support member defines a T-shaped slot. N expansion cone segments are movably coupled to the expansion cone support body, each including an expansion cone segment body including arcuate conical outer surfaces, a first T-shaped retaining member coupled to the expansion cone segment body for movably coupling the expansion cone segment body to a corresponding one of the T-shaped slots of the expansion cone support body, and a second T-shaped retaining member coupled to the expansion cone segment body. A split ring collar is movably coupled to the exterior of the tubular support member that includes a second tubular support body that defines N T-shaped slots for movably receiving corresponding ones of the second T-shaped retaining members of the expansion cone segments, and an L-shaped retaining member coupled to the second tubular support body. A first collet assembly is movably coupled to the tubular support member that includes a first tubular sleeve that defines a slot for receiving and mating with the L-shaped retaining member of the split ring collar, a first counterbore for receiving the first flange, and a first radial

passage, a first spring received within the first counterbore, a first retaining ring received within the first counterbore, a first load transfer pin coupled to the first retaining ring and extending through the first radial passage, a second tubular sleeve coupled to the first load transfer pin, a first resilient collet coupled to the second tubular sleeve and positioned above the first tapered flange, and a third tubular sleeve coupled to the first resilient collet. A second collet assembly is movably coupled to the tubular support member that includes a fourth tubular sleeve that defines a second counterbore for receiving the second flange, and a second radial passage, a second spring received within the second counterbore, a second retaining ring received within the second counterbore, a second load transfer pin coupled to the second retaining ring and extending through the second radial passage, a fifth tubular sleeve coupled to the second load transfer pin, a second resilient collet coupled to the fifth tubular sleeve and positioned above the second tapered flange, and a sixth tubular sleeve coupled to the second resilient collet. First and second packer cups coupled to the tubular support member between the first and second collet assemblies.

According to another aspect of the present invention, an apparatus for radially expanding a tubular member is provided that includes a tubular support member that includes a first tubular support body defining a longitudinal passage, a first radial passage defined in the first tubular support body fluidically coupled to the longitudinal passage, a first flange coupled to the first tubular support body, a second flange coupled to the first tubular support body, a first tapered flange coupled to the first tubular support body, a second tapered flange coupled to the first tubular support body, and an expansion cone support body coupled to the first tubular support body. The expansion cone support body includes an N-sided tapered tubular support member, wherein each side of the multi-sided tapered tubular support member defines a T-shaped slot. N expansion cone segments are movably coupled to the expansion cone support body, each including an expansion cone segment body including arcuate conical outer surfaces, a first T-shaped retaining member coupled to the expansion cone segment body for movably coupling the expansion cone segment body to a corresponding one of the T-shaped slots of the expansion cone support body, and a second T-shaped retaining member coupled to the expansion cone segment body. A split ring collar is movably coupled to the exterior of the tubular support member that includes a second tubular support body that defines N T-shaped slots for movably receiving corresponding ones of the second T-shaped retaining members of the expansion cone segments, and an L-shaped retaining member coupled to the second tubular support body. A first dog assembly is movably coupled to the tubular support

member that includes a first tubular sleeve that defines a slot for receiving and mating with the L-shaped retaining member of the split ring collar, a first counterbore for receiving the first flange, and a second radial passage, a first spring received within the first counterbore, a first retaining ring received within the first counterbore, a first load transfer pin coupled to the first retaining ring and extending through the second radial passage, and a second tubular sleeve coupled to the first load transfer pin that defines a second counterbore for receiving the first tubular sleeve, a first resilient dog coupled to the second tubular sleeve and positioned adjacent to the first tapered flange. A second dog assembly is movably coupled to the tubular support member that includes a third tubular sleeve that defines a second counterbore for receiving the second flange, a third radial passage, and a fourth radial passage fluidically coupled to the first radial passage, a second spring received within the second counterbore, a second retaining ring received within the second counterbore, a second load transfer pin coupled to the second retaining ring and extending through the third radial passage, a fourth tubular sleeve coupled to the second load transfer pin, and a second resilient dog coupled to the fourth tubular sleeve and positioned adjacent to the second tapered flange. First and second packer cups are coupled to the tubular support member between the first and second dog assemblies.

According to another aspect of the present invention, an apparatus for radially expanding a tubular member is provided that includes a tubular support member that includes a first tubular support body defining a longitudinal passage including a throat passage, a first radial passage defined in the first tubular support body fluidically coupled to the longitudinal passage, a first flange coupled to the first tubular support body, a second flange coupled to the first tubular support body that defines a second radial passage defined in the second flange fluidically coupled to the longitudinal passage, a tapered flange coupled to the first tubular support body, and an expansion cone support body coupled to the first tubular support body. The expansion cone support body includes an N-sided tapered tubular support member, wherein each side of the multi-sided tapered tubular support member defines a T-shaped slot. N expansion cone segments are movably coupled to the expansion cone support body, each including an expansion cone segment body including arcuate conical outer surfaces, a first T-shaped retaining member coupled to the expansion cone segment body for movably coupling the expansion cone segment body to a corresponding one of the T-shaped slots of the expansion cone support body, and a second T-shaped retaining member coupled to the expansion cone segment body. A split ring collar is movably coupled to the exterior of the tubular support member that includes a second tubular

support body that defines N T-shaped slots for movably receiving corresponding ones of the second T-shaped retaining members of the expansion cone segments, and an L-shaped retaining member coupled to the second tubular support body. A dog assembly is movably coupled to the tubular support member that includes a first tubular sleeve that defines a slot for receiving and mating with the L-shaped retaining member of the split ring collar, a first counterbore for receiving the first flange, and a third radial passage, a spring received within the first counterbore, a retaining ring received within the first counterbore, a load transfer pin coupled to the retaining ring and extending through the third radial passage, a second tubular sleeve coupled to the first load transfer pin that defines a first counterbore for receiving the first tubular sleeve, a second counterbore for receiving and mating with the tapered flange, and includes a third flange that defines a third counterbore for receiving the second flange, a fourth counterbore for receiving the second flange, and a fourth radial passage, and a resilient dog coupled to the second tubular sleeve and positioned adjacent to the tapered flange. First and second packer cups are coupled to the tubular support member between the resilient dog and the third flange.

According to another aspect of the present invention, an adjustable expansion cone assembly is provided that includes a tubular support member that includes a tubular support body and an expansion cone support body coupled to the tubular support body. The expansion cone support body includes an N-sided tapered tubular support member, wherein each side of the multi-sided tapered tubular support member defines a T-shaped slot. N expansion cone segments are movably coupled to the expansion cone support body, each including an expansion cone segment body including arcuate conical outer surfaces, a first T-shaped retaining member coupled to the expansion cone segment body for movably coupling the expansion cone segment body to a corresponding one of the T-shaped slots of the expansion cone support body, and a second T-shaped retaining member coupled to the expansion cone segment body. A split ring collar is movably coupled to the exterior of the tubular support member that includes a second tubular support body that defines N T-shaped slots for movably receiving corresponding ones of the second T-shaped retaining members of the expansion cone segments, and an L-shaped retaining member coupled to the second tubular support body. A tubular actuating sleeve is movably coupled to the tubular support member that includes a third tubular support body that defines a slot for receiving and mating with the L-shaped retaining member of the split ring collar.

According to another aspect of the present invention, an adjustable expansion cone assembly is provided that includes a tubular support member that includes a first tubular support body, and an expansion cone support body coupled to the tubular support body. The expansion cone support body includes a tapered tubular support member defining N stepped slots. An expansion cone assembly is movably coupled to the tubular support member that includes a second tubular support body movably coupled to the first tubular support body defining an L-shaped slot, and N expansion cone segments extending from the second tubular support member. Each expansion cone segment includes a resilient collet coupled to the second tubular support member, an expansion cone segment body coupled to the resilient collet including arcuate conical outer surfaces, and a retaining member coupled to the expansion cone segment body for movably coupling the expansion cone segment body to a corresponding one of the stepped slots of the expansion cone support body. A split ring collar is movably coupled to the exterior of the tubular support member that includes a third tubular support body, a first L-shaped retaining member coupled to the third tubular support body for mating with the L-shaped slot of the second tubular support body of the expansion cone assembly, and a second L-shaped retaining member coupled to the third tubular body. A tubular actuating sleeve is movably coupled to the tubular support member that includes a third tubular support body that defines a slot for receiving and mating with the second L-shaped retaining member of the split ring collar.

According to another aspect of the present invention, an adjustable expansion cone assembly is provided that includes a tubular support member that includes a first tubular support body, and an expansion cone support body coupled to the tubular support body. The expansion cone support body includes a tapered tubular support member defining N slots. An expansion cone assembly is movably coupled to the tubular support member that includes a second tubular support body movably coupled to the first tubular support body defining an L-shaped slot, and N expansion cone segments extending from the second tubular support member. Each expansion cone segment includes a resilient collet coupled to the second tubular support member, an expansion cone segment body coupled to the resilient collet including arcuate conical outer surfaces, and a retaining member coupled to the expansion cone segment body for movably coupling the expansion cone segment body to a corresponding one of the slots of the expansion cone support body. A split ring collar is movably coupled to the exterior of the tubular support member that includes a third tubular support body, a first L-shaped retaining member coupled to the third tubular support body for mating with

the L-shaped slot of the second tubular support body, and a second L-shaped retaining member coupled to the third tubular support body. A tubular actuating sleeve is movably coupled to the tubular support member that includes a third tubular support body that defines a slot for receiving and mating with the second L-shaped retaining member of the split ring collar.

According to another aspect of the present invention, an adjustable expansion cone assembly is provided that includes a tubular support member that includes a first tubular support body, and an expansion cone support body coupled to the tubular support body. The expansion cone support body includes a tapered tubular support member defining N slots. An expansion cone assembly is movably coupled to the tubular support member that includes a second tubular support body movably coupled to the first tubular support body defining an L-shaped slot, N/2 first expansion cone segments extending from the second tubular support member, and N/2 second expansion cone segments extending from the second tubular member. Each first expansion cone segment includes a first resilient collet coupled to the second tubular support member, a first expansion cone segment body coupled to the resilient collet including arcuate conical outer surfaces, and a first retaining member coupled to the expansion cone segment body for movably coupling the expansion cone segment body to a corresponding one of the slots of the expansion cone support body. Each second expansion cone segment includes a second resilient collet coupled to the second tubular support member, a second expansion cone segment body coupled to the resilient collet including arcuate conical outer surfaces, and a second retaining member coupled to the expansion cone segment body for movably coupling the expansion cone segment body to a corresponding one of the slots of the expansion cone support body. The second expansion cone segments overlap and are interleaved with the first expansion cone segments. A split ring collar is movably coupled to the exterior of the tubular support member that includes a third tubular support body, a first L-shaped retaining member coupled to the third tubular support body for mating with L-shaped slot of the second tubular support body, and a second L-shaped retaining member coupled to the third tubular support body. A tubular actuating sleeve is movably coupled to the tubular support member that includes a third tubular support body that defines a slot for receiving and mating with the second L-shaped retaining member of the split ring collar.

According to another aspect of the present invention, an adjustable expansion cone assembly is provided that includes a tubular support member that includes a first tubular support body, and an expansion cone support body coupled to the first tubular

support body. The expansion cone support body includes an N-sided tapered tubular support member, wherein each side of the multi-sided tapered tubular support member defines a T-shaped slot. N/2 first expansion cone segments are movably coupled to the expansion cone support body, each including a first expansion cone segment body including arcuate conical outer surfaces, a first T-shaped retaining member coupled to the first expansion cone segment body for movably coupling the first expansion cone segment body to a corresponding one of the T-shaped slots of the expansion cone support body, and a second T-shaped retaining member coupled to the first expansion cone segment body. N/2 second expansion cone segments are also movably coupled to the expansion cone support body, each including a second expansion cone segment body including arcuate conical outer surfaces, a third T-shaped retaining member coupled to the second expansion cone segment body for movably coupling the second expansion cone segment body to a corresponding one of the T-shaped slots of the expansion cone support body, and a fourth T-shaped retaining member coupled to the expansion cone segment body. The first and second expansion cone segments are interleaved. The first expansion cone segment bodies are complementary shaped with respect to the second expansion cone segment bodies. A split ring collar assembly is movably coupled to the exterior of the tubular support member that includes a second tubular support body that defines N T-shaped slots for movably receiving corresponding ones of the second and fourth T-shaped retaining members of the interleaved first and second expansion cone segments, and an L-shaped retaining member coupled to the second tubular support body. A tubular actuating sleeve movably coupled to the tubular support member that includes a third tubular support body that defines a slot for receiving and mating with the L-shaped retaining member of the split ring collar.

According to another aspect of the present invention, an apparatus for radially expanding a tubular member is provided that includes a tubular support member that includes a first tubular support body defining a longitudinal passage, a first lug coupled to and extending from the first tubular support body in the radial direction, and a second lug coupled to and extending from the first tubular support body in the radial direction. An adjustable expansion cone assembly is movably coupled to the tubular support member. A first drag block assembly is movably coupled to the tubular support member that includes a first drag block body coupled to the adjustable expansion cone assembly that defines: a first J-shaped slot for receiving the first lug, and one or more first drag blocks coupled to the first drag block body. A second drag block assembly is

movably coupled to the tubular support member that includes a second drag block body that defines: a second J-shaped slot for receiving the second lug, and one or more second drag blocks coupled to the second drag block body. First and second packer cups are coupled to the tubular support member between the first and second drag block assemblies.

According to another aspect of the present invention, an apparatus for radially expanding a tubular member is provided that includes a tubular support member that includes a first tubular support body defining a longitudinal passage, a first flange coupled to the first tubular support body, a second flange coupled to the first tubular support body, a first tapered flange coupled to the first tubular support body, and a second tapered flange coupled to the first tubular support body. An adjustable expansion cone assembly is movably coupled to the tubular support member. A first collet assembly is movably coupled to the tubular support member that includes a first tubular sleeve coupled to the adjustable expansion cone assembly and defines a first counterbore for receiving the first flange, and a first radial passage, a first spring received within the first counterbore, a first retaining ring received within the first counterbore, a first load transfer pin coupled to the first retaining ring and extending through the first radial passage, a second tubular sleeve coupled to the first load transfer pin, a first resilient collet coupled to the second tubular sleeve and positioned above the first tapered flange, and a third tubular sleeve coupled to the first resilient collet. A second collet assembly is movably coupled to the tubular support member that includes a fourth tubular sleeve that defines: a second counterbore for receiving the second flange, and a second radial passage, a second spring received within the second counterbore, a second retaining ring received within the second counterbore, a second load transfer pin coupled to the second retaining ring and extending through the second radial passage, a fifth tubular sleeve coupled to the second load transfer pin, a second resilient collet coupled to the fifth tubular sleeve and positioned above the second tapered flange, and a sixth tubular sleeve coupled to the second resilient collet. First and second packer cups are coupled to the tubular support member between the first and second collet assemblies.

According to another aspect of the present invention, an apparatus for radially expanding a tubular member is provided that includes a tubular support member that includes a first tubular support body defining a longitudinal passage, a first radial passage defined in the first tubular support body fluidically coupled to the longitudinal passage, a first flange coupled to the first tubular support body, a second flange coupled to the first tubular support body, a first tapered flange coupled to the first

tubular support body, and a second tapered flange coupled to the first tubular support body. An adjustable expansion cone assembly is movably coupled to the tubular support member. A first dog assembly is movably coupled to the tubular support member that includes a first tubular sleeve coupled to the adjustable expansion cone assembly that defines: a first counterbore for receiving the first flange, and a second radial passage, a first spring received within the first counterbore, a first retaining ring received within the first counterbore, a first load transfer pin coupled to the first retaining ring and extending through the second radial passage, a second tubular sleeve coupled to the first load transfer pin that defines: a second counterbore for receiving the first tubular sleeve, a first resilient dog coupled to the second tubular sleeve and positioned adjacent to the first tapered flange. A second dog assembly is movably coupled to the tubular support member that includes a third tubular sleeve that defines a second counterbore for receiving the second flange; a third radial passage, and a fourth radial passage fluidically coupled to the first radial passage, a second spring received within the second counterbore, a second retaining ring received within the second counterbore, a second load transfer pin coupled to the second retaining ring and extending through the third radial passage, a fourth tubular sleeve coupled to the second load transfer pin, a second resilient dog coupled to the fourth tubular sleeve and positioned adjacent to the second tapered flange. First and second packer cups are coupled to the tubular support member between the first and second dog assemblies.

According to another aspect of the present invention, an apparatus for radially expanding a tubular member is provided that includes a tubular support member that includes a first tubular support body defining a longitudinal passage including a throat passage, a first radial passage defined in the first tubular support body fluidically coupled to the longitudinal passage, a first flange coupled to the first tubular support body, and a second flange coupled to the first tubular support body that defines: a second radial passage defined in the second flange fluidically coupled to the longitudinal passage. An adjustable expansion cone assembly is movably coupled to the tubular support member. A dog assembly is movably coupled to the tubular support member that includes a first tubular sleeve coupled to the adjustable expansion cone assembly that defines a first counterbore for receiving the first flange, and a third radial passage, a spring received within the first counterbore, a retaining ring received within the first counterbore, a load transfer pin coupled to the retaining ring and extending through the third radial passage, a second tubular sleeve coupled to the first load transfer pin that defines: a first counterbore for receiving the first tubular sleeve, a second counterbore

for receiving and mating with the tapered flange, and includes a third flange that defines a third counterbore for receiving the second flange, a fourth counterbore for receiving the second flange, and a fourth radial passage, and a resilient dog coupled to the second tubular sleeve and positioned adjacent to the tapered flange. First and
5 second packer cups are coupled to the tubular support member between the resilient dog and the third flange.

According to another aspect of the present invention, an apparatus for radially expanding a tubular member is provided that includes a tubular support member, an adjustable expansion cone assembly movably coupled to the tubular support member,
10 and means for adjusting the adjustable expansion cone assembly.

According to another aspect of the present invention, an adjustable expansion cone assembly is provided that includes a tubular support member. An adjustable expansion cone is movably coupled to the tubular support member that includes a plurality of expansion cone segments, and means for guiding the expansion cone
15 segments on the tubular support member. The assembly further includes means for adjusting the adjustable expansion cone.

According to another aspect of the present invention, a method of operating an adjustable expansion cone assembly including a plurality of expansion cone segments is provided that includes guiding the expansion cone segments on a tapered body, and
20 controllably displacing the expansion cone segments along the tapered body.

According to another aspect of the present invention, a method of operating an adjustable expansion cone assembly including a plurality of expansion cone segments is provided that includes guiding the expansion cone segments on a multi-sided tapered body, interlocking the expansion cone segments, and controllably displacing
25 the expansion cone segments along the tapered body.

According to another aspect of the present invention, a method of operating an adjustable expansion cone assembly including a plurality of expansion cone segments is provided that includes resiliently guiding the expansion cone segments on a multi-sided tapered body, guiding each of the expansion cone segments on opposite sides in
30 the circumferential direction, interlocking the expansion cone segments, and controllably displacing the expansion cone segments along the tapered body.

According to another aspect of the present invention, a method of operating an adjustable expansion cone assembly including a plurality of expansion cone segments is provided that includes dividing the expansion cone segments into first and second
35 groups of expansion cone segments, interleaving the first and second groups of expansion cone segments, overlapping the first and second groups of expansion cone

segments, resiliently guiding the expansion cone segments on a multi-sided tapered body, guiding each of the expansion cone segments on opposite sides in the circumferential direction, and controllably displacing the expansion cone segments along the tapered body.

5 According to another aspect of the present invention, a method of operating an adjustable expansion cone assembly including a plurality of expansion cone segments is provided that includes dividing the expansion cone segments into first and second groups of expansion cone segments, interleaving the first and second groups of expansion cone segments, guiding the expansion cone segments on a multi-sided
10 tapered body, and controllably displacing the expansion cone segments along the tapered body while also relatively displacing the first and second groups of expansion cone segments in opposite directions.

 According to another aspect of the present invention, a method of plastically deforming and radially expanding an expandable tubular member using an apparatus
15 including a tubular support member, an adjustable expansion cone assembly movably coupled to the tubular support member, and an actuator movably coupled to the tubular support member for adjusting the adjustable expansion cone assembly, is provided that includes coupling a first end of the expandable tubular member to a tubular structure, locking the actuator to the tubular support member of the apparatus, inserting the
20 apparatus into the first end of the expandable tubular member, moving the actuator and the adjustable expansion cone assembly of the apparatus out of the second end of the expandable tubular member, reinserting the actuator of the apparatus into the second end of the expandable tubular member, unlocking the actuator from the tubular support member of the apparatus, rotating the actuator relative to the tubular support member
25 of the apparatus, and increasing the outside diameter of the adjustable expansion cone assembly by moving the tubular support member relative to the actuator, the adjustable expansion cone assembly and the expandable tubular member, and plastically deforming and radially expanding the expandable tubular member by moving the adjustable expansion cone assembly through the expandable tubular member.

30 According to another aspect of the present invention, a method of plastically deforming and radially expanding an expandable tubular member using an apparatus including a tubular support member, an adjustable expansion cone assembly movably coupled to the tubular support member, and an actuator movably coupled to the tubular support member for adjusting the adjustable expansion cone assembly, is provided that
35 includes coupling a first end of the expandable tubular member to a tubular structure, inserting the apparatus into the first end of the expandable tubular member in a first

direction, displacing the actuator of the apparatus in a second direction opposite to the first direction, applying a resilient biasing force to the adjustable expansion cone assembly in the second direction, moving the actuator and the adjustable expansion cone assembly of the apparatus out of the second end of the expandable tubular member, reinserting the actuator of the apparatus into the second end of the expandable tubular member in the second direction, increasing the outside diameter of the adjustable expansion cone assembly by displacing the actuator and the adjustable expansion cone assembly relative to the expandable tubular member in the first direction, and plastically deforming and radially expanding the expandable tubular member by moving the adjustable expansion cone assembly through the expandable tubular member in the second direction.

According to another aspect of the present invention, an adjustable expansion cone assembly is provided that includes a plurality of expansion cone segments, means for guiding the expansion cone segments on a tapered body, and means for controllably displacing the expansion cone segments along the tapered body.

According to another aspect of the present invention, an adjustable expansion cone assembly is provided that includes a plurality of expansion cone segments, means for guiding the expansion cone segments on a multi-sided tapered body, means for interlocking the expansion cone segments, and means for controllably displacing the expansion cone segments along the tapered body.

According to another aspect of the present invention, an adjustable expansion cone assembly is provided that includes a plurality of expansion cone segments, means for resiliently guiding the expansion cone segments on a multi-sided tapered body, means for guiding each of the expansion cone segments on opposite sides in the circumferential direction, means for interlocking the expansion cone segments, and means for controllably displacing the expansion cone segments along the tapered body.

According to another aspect of the present invention, an adjustable expansion cone assembly is provided that includes a plurality of expansion cone segments, means for dividing the expansion cone segments into first and second groups of expansion cone segments, means for interleaving the first and second groups of expansion cone segments, means for overlapping the first and second groups of expansion cone segments, means for resiliently guiding the expansion cone segments on a multi-sided tapered body, means for guiding each of the expansion cone segments on opposite sides in the circumferential direction, and means for controllably displacing the expansion cone segments along the tapered body.

According to another aspect of the present invention, an adjustable expansion cone assembly is provided that includes a plurality of expansion cone segments, means for dividing the expansion cone segments into first and second groups of expansion cone segments, means for interleaving the first and second groups of expansion cone segments, means for interleaving the first and second groups of expansion cone segments, means for guiding the expansion cone segments on a multi-sided tapered body, and means for controllably displacing the expansion cone segments along the tapered body while also relatively displacing the first and second groups of expansion cone segments in opposite directions.

According to another aspect of the present invention, an apparatus for plastically deforming and radially expanding an expandable tubular member is provided that includes a tubular support member, an adjustable expansion cone assembly movably coupled to the tubular support member, means for actuating the adjustable expansion cone assembly, means for locking the actuator to the tubular support member of the apparatus, means for unlocking the actuator from the tubular support member of the apparatus, and means for increasing the outside diameter of the adjustable expansion cone assembly by moving the tubular support member relative to the actuator, the adjustable expansion cone assembly, and the expandable tubular member.

According to another aspect of the present invention, an apparatus for plastically deforming and radially expanding an expandable tubular member is provided that includes a tubular support member, an adjustable expansion cone assembly movably coupled to the tubular support member, means for actuating the adjustable expansion cone assembly, means for displacing the actuator of the apparatus in a first direction, means for applying a resilient biasing force to the adjustable expansion cone assembly when the actuator is displaced in the first direction, and means for increasing the outside diameter of the adjustable expansion cone assembly by displacing the actuator and the adjustable expansion cone assembly relative to the expandable tubular member in a second direction opposite to the first direction.

Brief Description of the Drawings

Figs. 1 and 1a-1d are fragmentary cross-sectional views of an embodiment of the placement of an apparatus for radially expanding a tubular member within a tubular member within a borehole within a subterranean formation.

Fig. 1e is a cross-sectional view of an embodiment of the expansion cone support body of the apparatus of Figs. 1 and 1a-1d.

Fig. 1f is a cross-sectional view of the expansion cone support body of Fig. 1e.

Fig. 1g is a side view of an embodiment of an expansion cone segment for use in the apparatus of Figs. 1 and 1a-1d.

Fig. 1h is a front view of the expansion cone segment of Fig. 1g.

Fig. 1i is a top view of the expansion cone segment of Fig. 1g.

5 Fig. 1j is a top view of an embodiment of interlocking expansion cone segments for use in the apparatus of Figs. 1 and 1a-1d.

Fig. 1k is a top fragmentary circumferential view of an embodiment of the coupling arrangement between the expansion cone segments and the split ring collar for use in the apparatus of Figs. 1 and 1a-1d.

10 Figs. 1l and 1m are top schematic views of an embodiment of the coupling between the J-slots of the drag blocks and the lugs of the tubular support member of the apparatus of Figs. 1 and 1a-1d.

Figs. 2 and 2a-2d are fragmentary cross-sectional illustrations of the apparatus of Figs. 1 and 1a-1d during the radial expansion of the tubular member within the borehole within the subterranean formation.

Figs. 2e and 2f are illustrations of an embodiment of the J-slots of the drag blocks and the lugs of the tubular support member of the apparatus of Figs. 2 and 2a-2d.

20 Figs. 2g and 2h are illustrations of an alternative embodiment of the J-slots of the drag blocks and the lugs of the tubular support member of the apparatus of Figs. 2 and 2a-2d.

Figs. 3 and 3a-3c are fragmentary cross-sectional illustrations of an embodiment of the placement of an apparatus for radially expanding a tubular member within a wellbore casing within a subterranean formation.

25 Fig. 3d is a cross-sectional view of an embodiment of the expansion cone support body of the apparatus of Figs. 3 and 3a-3c.

Fig. 3e is a cross-sectional view of the expansion cone support body of Fig. 3d.

Fig. 3f is a side view of an embodiment of an expansion cone segment for use in the apparatus of Figs. 3 and 3a-3c.

30 Fig. 3g is a front view of the expansion cone segment of Fig. 3f.

Fig. 3h is a top view of the expansion cone segment of Fig. 3f.

Fig. 3i is a top view of an embodiment of interlocking expansion cone segments for use in the apparatus of Figs. 3 and 3a-3c.

35 Fig. 3j is a top fragmentary circumferential view of an embodiment of the coupling arrangement between the expansion cone segments and the split ring collar for use in the apparatus of Figs. 3 and 3a-3c.

Figs. 4 and 4a-4d are fragmentary cross-sectional illustrations of an embodiment of the placement of the apparatus of Figs. 3 and 3a-3c including an expandable tubular member within an expandable tubular member within a subterranean formation.

5 Figs. 5 and 5a-5d are fragmentary cross-sectional illustrations of an embodiment of the operation of the apparatus of Figs. 4 and 4a-4d during the radial expansion of the expandable tubular member within the borehole within the subterranean formation.

10 Figs. 6 and 6a-6d are fragmentary cross-sectional illustrations of an embodiment of the placement of an apparatus for radially expanding a tubular member within a borehole within a subterranean formation.

Fig. 6e is a cross-sectional view of an embodiment of the expansion cone support body of the apparatus of Figs. 6 and 6a-6d.

Fig. 6f is a cross-sectional view of the expansion cone support body of Fig. 6e.

15 Fig. 6g is a side view of an embodiment of an expansion cone segment for use in the apparatus of Figs. 6 and 6a-6d.

Fig. 6h is a front view of the expansion cone segment of Fig. 6g.

Fig. 6i is a top view of the expansion cone segment of Fig. 6g.

20 Fig. 6j is a top view of an embodiment of interlocking expansion cone segments for use in the apparatus of Figs. 6 and 6a-6d.

Fig. 6k is a top fragmentary circumferential view of an embodiment of the coupling arrangement between the expansion cone segments and the split ring collar for use in the apparatus of Figs. 6 and 6a-6d.

25 Figs. 7 and 7a-7c are fragmentary cross-sectional illustrations of an embodiment of the placement of the apparatus of Figs. 6 and 6a-6d including an expandable tubular member within a borehole within a subterranean formation.

30 Figs. 8 and 8a-8d are fragmentary cross-sectional illustrations of an embodiment of the operation of the apparatus of Figs. 7 and 7a-7d during the radial expansion of the expandable tubular member within a borehole within a subterranean formation.

Fig. 9 is a fragmentary cross sectional illustration of an embodiment of an expansion cone assembly in an unexpanded position.

Fig. 9a is a cross sectional illustration of the expansion cone assembly of Fig. 9.

35 Fig. 10 is a fragmentary cross sectional illustration of the expansion cone assembly of Fig. 9 in an expanded position.

Fig. 10a is a cross sectional illustration of the expansion cone assembly of Fig. 10.

Fig. 11 is a fragmentary cross sectional illustration of an embodiment of an expansion cone assembly in an unexpanded position.

5 Fig. 11a is a cross sectional illustration of the expansion cone assembly of Fig. 11.

Fig. 12 is a fragmentary cross sectional illustration of the expansion cone assembly of Fig. 11 in an expanded position.

10 Fig. 12a is a cross sectional illustration of the expansion cone assembly of Fig. 12.

Fig. 13 is a fragmentary cross sectional illustration of an embodiment of an expansion cone assembly in an unexpanded position.

Fig. 13a is a cross sectional illustration of the expansion cone assembly of Fig. 13.

15 Fig. 13b is a fragmentary top circumferential illustration of the expansion cone segment assembly of Fig. 13 that illustrates the interleaved sets of collets.

Fig. 13c is a fragmentary cross sectional illustration of the interleaved collets of Fig. 13b.

20 Fig. 14 is a fragmentary cross sectional illustration of the expansion cone assembly of Fig. 13 in an expanded position.

Fig. 14a is a cross sectional illustration of the expansion cone assembly of Fig. 14.

25 Figs. 15 and 15a-15c are fragmentary cross-sectional illustrations of an embodiment of the placement of an apparatus for radially expanding a tubular member within a borehole within a subterranean formation.

Fig. 15d is a cross-sectional view of an embodiment of the expansion cone support body of the apparatus of Figs. 15 and 15a-15c.

Fig. 15e is a cross-sectional view of the expansion cone support body of Fig. 15d.

30 Fig. 15f is a side view of an embodiment of an expansion cone segment for use in the apparatus of Figs. 15 and 15a-15c.

Fig. 15g is a front view of the expansion cone segment of Fig. 15f.

Fig. 15h is a top view of the expansion cone segment of Fig. 15f.

35 Fig. 15i is a top view of an embodiment of interlocking expansion cone segments for use in the apparatus of Figs. 15 and 15a-15c.

Fig. 15j is a top fragmentary circumferential view of an embodiment of the coupling arrangement between the expansion cone segments and the split ring collar for use in the apparatus of Figs. 15 and 15a-15c.

5 Figs. 16 and 16a-16c are fragmentary cross-sectional illustrations of an embodiment of the placement of the apparatus of Figs. 15 and 15a-15j including an expandable tubular member within a borehole within a subterranean formation.

10 Figs. 17 and 17a-17c are fragmentary cross-sectional illustrations of an embodiment of the operation of the apparatus of Figs. 16 and 16a-16c during the radial expansion of the expandable tubular member within a borehole within a subterranean formation.

Fig. 18a is a cross sectional illustration of an embodiment of a segmented expansion cone assembly in an unexpanded position.

Fig. 18b is a fragmentary circumferential top illustration of the expansion cone and split ring collar of Fig. 18a.

15 Fig. 18c is a fragmentary cross-sectional illustration of the expansion cone support flange of the expansion cone assembly of Fig. 18a.

Fig. 18d is a cross-sectional illustration of the expansion cone support flange of Fig. 18c.

20 Fig. 19a is a cross sectional illustration of an embodiment of the segmented expansion cone assembly of Fig. 18a in an expanded position.

Fig. 19b is a fragmentary circumferential top view of the expansion cone of Fig. 19a.

25 Figs. 20a-20m are top circumferential views of various alternative embodiments of interlocking expansion cone segment geometries.

25 **Detailed Description of the Illustrative Embodiments**

Referring initially to Figs. 1 and 1a-1d, an embodiment of an apparatus and method for radially expanding a tubular member will now be described. As illustrated in Figs. 1 and 1a-1d, a wellbore 100 is positioned in a subterranean formation 105. In an exemplary embodiment, the wellbore 100 may include a pre-existing cased section

30 110. The wellbore 100 may be positioned in any orientation from vertical to horizontal.

In order to extend the wellbore 100 into the subterranean formation 105, a drill string is used in a well known manner to drill out material from the subterranean formation 105 to form a new wellbore section 115. In a preferred embodiment, the inside diameter of the new wellbore section 115 is greater than or equal to the inside

35 diameter of the preexisting wellbore casing 110.

A tubular member 120 defining a passage 120a may then be positioned within the wellbore section 115 with the upper end 120b of the tubular member coupled to the wellbore casing 110 and the lower end 120c of the tubular member extending into the wellbore section. The tubular member 120 may be positioned within the wellbore section 115 and coupled to the wellbore casing 110 in a conventional manner. In a preferred embodiment, the tubular member 120 is positioned within the wellbore section 115 and coupled to the wellbore casing 110 using one or more of the methods and apparatus disclosed in one or more of the following: (1) U.S. patent application serial no. 09/454,139, attorney docket no. 25791.03.02, filed on 12/3/1999, (2) U.S. patent application serial no. 09/510,913, attorney docket no. 25791.7.02, filed on 2/23/2000, (3) U.S. patent application serial no. 09/502,350, attorney docket no. 25791.8.02, filed on 2/10/2000, (4) U.S. patent application serial no. 09/440,338, attorney docket no. 25791.9.02, filed on 11/15/1999, (5) U.S. patent application serial no. 09/523,460, attorney docket no. 25791.11.02, filed on 3/10/2000, (6) U.S. patent application serial no. 09/512,895, attorney docket no. 25791.12.02, filed on 2/24/2000, (7) U.S. patent application serial no. 09/511,941, attorney docket no. 25791.16.02, filed on 2/24/2000, (8) U.S. patent application serial no. 09/588,946, attorney docket no. 25791.17.02, filed on 6/7/2000, (9) U.S. patent application serial no. 09/559,122, attorney docket no. 25791.23.02, filed on 4/26/2000, (10) PCT patent application serial no. PCT/US00/18635, attorney docket no. 25791.25.02, filed on 7/9/2000, (11) U.S. provisional patent application serial no. 60/162,671, attorney docket no. 25791.27, filed on 11/1/1999, (12) U.S. provisional patent application serial no. 60/154,047, attorney docket no. 25791.29, filed on 9/16/1999, (13) U.S. provisional patent application serial no. 60/159,082, attorney docket no. 25791.34, filed on 10/12/1999, (14) U.S. provisional patent application serial no. 60/159,039, attorney docket no. 25791.36, filed on 10/12/1999, (15) U.S. provisional patent application serial no. 60/159,033, attorney docket no. 25791.37, filed on 10/12/1999, (16) U.S. provisional patent application serial no. 60/212,359, attorney docket no. 25791.38, filed on 6/19/2000, (17) U.S. provisional patent application serial no. 60/165,228, attorney docket no. 25791.39, filed on 11/12/1999, (18) U.S. provisional patent application serial no. 60/221,443, attorney docket no. 25791.45, filed on 7/28/2000, (19) U.S. provisional patent application serial no. 60/221,645, attorney docket no. 25791.46, filed on 7/28/2000, (20) U.S. provisional patent application serial no. 60/233,638, attorney docket no. 25791.47, filed on 9/18/2000, (21) U.S. provisional patent application serial no. 60/237,334, attorney docket no. 25791.48, filed on 10/2/2000, (22) U.S. provisional patent application serial no. 60/270,007, attorney docket no. 25791.50, filed on 2/20/2001; and (23) U.S.

provisional patent application serial no. 60/262,434, attorney docket no. 25791.51, filed on 1/17/2001; and (24) U.S. provisional patent application serial no. 60/259,486, attorney docket no. 25791.52, filed on 1/3/2001, the disclosures of which are incorporated herein by reference.

5 As illustrated in Figs. 1 and 1a-1d, an apparatus 200 for radially expanding a tubular member may then be positioned in the new section 115 of the wellbore 100 within the tubular member 120. The apparatus 200 includes a tubular support member 205 defining an internal passage 205a that is coupled to an end of a tubular coupling 210 defining an internal passage 210a. The other end of the tubular coupling 210 is
10 coupled to an end of a tubular support member 215 defining an internal passage 215a that includes a first lug 215b, a radial passage 215c, a first flange 215d, a second flange 215e, a second lug 215f, and an expansion cone support body 215g. The other end of the tubular support member 215 is coupled to a tubular end stop 220 that defines a passage 220a.

15 As illustrated in Figs. 1e and 1f, the expansion cone support body 215g includes a first end 215ga, a tapered hexagonal portion 215gb that includes a plurality of T-shaped slots 215gba provided on each of the external faceted surfaces of the tapered hexagonal portion, and a second end 215gc. In an exemplary embodiment, the angle of attack of the tapered hexagonal portion ranges from about 35 to 50
20 degrees for reasons to be described.

 As illustrated in Figs. 1, 1a-1d, 1g, 1h, and 1i, a plurality of expansion cone segments 225 are provided that include first ends 225a that include T-shaped retaining members 225aa and second ends 225b that include T-shaped retaining members 225ba that mate with and are received within corresponding T-shaped slots 215gba on
25 the tapered hexagonal portion 215gb of the expansion cone support body 215g, first external surfaces 225bb, second external surfaces 225bc, and third external surfaces 225bd. Thus, in an exemplary embodiment, a total of six expansion cone segments 225 are provided that are slidably coupled to corresponding sides of the tapered hexagonal portion 215gb of the expansion cone support body.

30 In an exemplary embodiment, the widths of the first external surfaces 225bb of the expansion cone segments 225 increase in the direction of the second external surfaces 225bc, the widths of the second external surfaces are substantially constant, and the widths of the third external surfaces 225bd decrease in the direction of the first ends 225a of the expansion cone segments for reasons to be described. In an
35 exemplary embodiment, the first external surfaces 225bb of the expansion cone segments 225 taper upwardly in the direction of the second external surfaces 225bc,

the second external surfaces taper upwardly in the direction of the third external surfaces 225bd, and the third external surfaces 225bd taper downwardly in the direction of the first ends 225a of the expansion cone segments for reasons to be described. In an exemplary embodiment, the angle of attack of the taper of the first external surfaces 225bb of the expansion cone segments 225 are greater than the angle of attack of the taper of the second external surfaces 225bc. In an exemplary embodiment, the first and second external surfaces, 225bb and 225bc, of the expansion cone segments 225 are arcuate such that when the expansion cone segments 225 are displaced in the direction of the end stop 220, the first and second external surfaces of the expansion cone segments provide a substantially continuous outer circumferential surface for reasons to be described.

As illustrated in Fig. 1j, in an exemplary embodiment, the external surfaces, 225bb, 225bc, and 225bd, of the second ends 225b of the expansion cone segments 225 are adapted to mate with one another in order to interlock adjacent expansion cone segments.

As illustrated in Figs. 1, 1a-1d, and 1k, a split ring collar 230 that defines a passage 230a for receiving the tubular support member 215 is provided that includes a first end that includes plurality of T-shaped slots 230b for receiving and mating with corresponding T-shaped retaining members 225aa of the expansion cone segments 225 and a second end that includes an L-shaped retaining member 230c. In an exemplary embodiment, the split ring collar 230 is a conventional split ring collar commercially available from Halliburton Energy Services modified in accordance with the teachings of the present disclosure.

As illustrated in Figs. 1, 1a-1d, and 1m, a drag block assembly 235 that defines a passage 235a for receiving the tubular support member 215 is provided that includes a first end that includes an L-shaped slot 235b for receiving and mating with the L-shaped retaining member 230c of the split ring collar 230, one or more conventional drag block elements 235c, and a J-shaped slot 235d including a retaining slot 235da for receiving the second lug 215f of the tubular support member 215. In an exemplary embodiment, the longitudinal axis of the J-shaped slot 235d of the drag block assembly 235 is substantially parallel to the longitudinal axis of the tubular support member 215 for reasons to be described.

A first conventional packer cup assembly 240 that defines a passage 240a for receiving the tubular support member 215 includes a first end 240b that mates with the second flange 215e of the tubular support member, a conventional sealing cup 240c, and a second end 240d. A tubular spacer 245 that defines a passage 245a for

receiving the tubular support member 215 includes a first end 245b that mates with the second end 240c of the first packer cup assembly 240 and a second end 245c. A second conventional packer cup assembly 250 that defines a passage 250a for receiving the tubular support member 215 includes a first end 250b that mates with the second end 245c of the spacer 245, a conventional sealing cup 250c, and a second end 250d that mates with the first flange 215d of the tubular support member.

As illustrated in Figs. 1, 1a-1d, and 1l, a drag block assembly 255 that defines a passage 255a for receiving the tubular support member 215 is provided that includes a first end that includes sealing members, 255b and 255c, one or more conventional drag block elements 255d, and a J-shaped slot 255e including a retaining slot 255ea for receiving the first lug 215b of the tubular support member 215. In an exemplary embodiment, the longitudinal axis of the J-shaped slot 255e of the drag block assembly 255 is substantially parallel to the longitudinal axis of the tubular support member 215 for reasons to be described.

In an exemplary embodiment, during operation of the apparatus 200, as illustrated in Figs. 1 and 1a-1m, the apparatus may be positioned in the wellbore 115, within the tubular member 120, with the first and second lugs, 215b and 215f, respectively, positioned within the retaining slots, 255ea and 235da, respectively, of the J-slots, 255e and 235da, respectively, of the drag block assembly 255 and 235, respectively. In this manner, the drag block assembly 235 is maintained in a substantially stationary position relative to the tubular support member 215 thereby preventing the expansion cone segments 225 from being displaced downwardly in the longitudinal direction relative to the tubular support member 215 towards the end stop 220. Furthermore, in this manner, the drag block assembly 255 is also maintained in a substantially stationary position relative to the tubular support member 215 thereby preventing the drag block assembly from sealing off the radial passage 215c. In an exemplary embodiment, during the placement of the apparatus 200 within the wellbore 115 and the tubular member 120, the radial passage 215c permits fluidic materials outside of the tubular support member 215 to pass into the passage 215a thereby minimizing overpressure conditions within the annulus outside of the tubular support member.

In an exemplary embodiment, the apparatus 200 is positioned within the expandable tubular member 120 such that the expansion cone body 215g, the end stop 220, and the expansion cone segments 225 extend out of the expandable tubular member. In this manner, the expansion cone segments 225 may be driven up the tapered hexagonal portion 215gb of the expansion cone body 215g, thereby increasing

the outside diameters of the expansion cone segments, without impacting the expandable tubular member 120.

The tubular support member 215 may then be rotated relative to the drag block assemblies, 235 and 255, thereby displacing the lugs, 215f and 215b, with respect to the J-shaped slots, 235d and 255e, respectively. The tubular support member 215 may then be displaced upwardly relative to the drag block assemblies, 235 and 255, in the longitudinal direction thereby displacing the drag block assemblies downwardly relative to the tubular support member. During the longitudinal upward displacement of the tubular support member 215 relative to the drag block assemblies, 235 and 255, the drag block assemblies, 235 and 255, are maintained in a substantially stationary position with respect to the expandable tubular member 120 by the frictional forces exerted by the drag blocks, 235c and 255d, of the drag block assemblies on the expandable tubular member, and during the upward longitudinal displacement of the tubular support member 215 relative to the drag block assemblies, the lugs, 215f and 215b, are guided in a substantially longitudinal direction by the J-slots, 235d and 255e, respectively, of the drag block assemblies.

The downward longitudinal displacement of the drag block assembly 235 relative to the tubular support member 215 displaces the split ring collar 230 downwardly along with the expansion cone segments 225. As a result, the expansion cone segments 225 are driven up the tapered hexagonal portion 215gb of the expansion cone support body 215g until the end faces of the expansion cone segments impact the stop member 220. As a result, the outside diameter of the expansion cone segments 225 increases. In an exemplary embodiment, once the expansion cone segments 225 impact the stop member 220, the outer surfaces, 225bb and 225bc, of the expansion cone segments provide a substantially continuous outer surface in the circumferential direction having a diameter that is greater than the inside diameter of the expandable tubular member 120. The downward longitudinal displacement of the drag block assembly 255 relative to the tubular support member 215 seals off the radial passage 215c thereby preventing the pressurized fluidic material 275 from entering the annulus surrounding the tubular support member 215 through the radial passage.

In an exemplary embodiment, as illustrated in Figs. 2 and 2a-2f, the expandable tubular member 120 may then be radially expanded using the apparatus 200 by injecting a fluidic material 275 into the apparatus through the passages 205a, 210a, and 215a. The injection of the fluidic material 275 may pressurize the interior 120a of the expandable tubular member 120. In addition, because the packer cup assemblies, 240 and 250, seal off an annular region 120aa below the packer cup assemblies

between the expandable tubular member 120 and the tubular support member 215, the injection of the fluidic material 275 may also pressurize the annular region.

The continued injection of the fluidic material 275 may then pressurize the interior 120a of the expandable tubular member 120 thereby plastically deforming and
5 radially expanding the expandable tubular member off of the expansion cone segments 225. Because the outer surfaces, 225bb and 225bc, of the expansion cone segments 225 are tapered, the plastic deformation and radial expansion of the expandable tubular member 120 proximate the expansion cone segments is facilitated.
Furthermore, in an exemplary embodiment, the continued injection of the fluidic
10 material 275 also pressurizes the annular region 120aa defined between the interior surface of the expandable tubular member 120 and the exterior surface of the tubular support member 215 that is bounded on the upper end by the packer cup assembly 240 and on the lower end by the expansion cone segments 225. Furthermore, in an exemplary embodiment, the pressurization of the annular region 120aa also radially
15 expands the surrounding portion of the expandable tubular member 120. In this manner, the plastic deformation and radial expansion of the expandable tubular member 120 is enhanced. Furthermore, during operation of the apparatus 200, the packer cup assemblies 240 and 250 prevent the pressurized fluidic material 275 from passing above and beyond the packer cup assemblies and thereby define the length of
20 the pressurized annular region 120aa. In an exemplary embodiment, the pressurization of the annular region 120aa decreases the operating pressures required for plastic deformation and radial expansion of the expandable tubular member 120 by as much as 50% and also reduces the angle of attack of the tapered external surfaces, 225bb and 225bc, of the expansion cone segments 225.

25 The radial expansion of the expandable tubular member 120 may then continue until the upper end 120b of the expandable tubular member is radially expanded and plastically deformed along with the overlapping portion of the wellbore casing 110. Because the expansion cone segments 225 may be adjustable positioned from an outside diameter less than the inside diameter of the expandable tubular member 120
30 to an outside diameter substantially equal to the inside diameter of the pre-existing casing 110, the resulting wellbore casing, including the casing 110 and the radially expanded tubular member 120, created by the operation of the apparatus 200 may have a single substantially constant inside diameter thereby providing a mono-diameter wellbore casing.

35 If the expansion cone segments 225 become lodged within the tubular member 120 during the radial expansion process, the tubular support member 215 may be

displaced downwardly in the longitudinal direction and then rotated relative to the drag block assemblies, 235 and 255, thereby positioning the lugs, 215b and 215f, within the retaining slots, 255ea and 235da, respectively, of the J-slots, 255e and 235d, respectively. As a result, the expansion cone segments 225 may be displaced down
5 the tapered hexagonal portion 215gb of the expansion cone support body 215g and away from the end stop 220 thereby decreasing the external diameter of the expansion cone segments. In this manner, the tubular support member 205, the tubular support member 210, the tubular support member 215, the end stop 220, the expansion cone segments 225, the split ring collar 230, the drag block assembly 235, the pack cup
10 assembly 240, the spacer 245, the packer cup assembly 250, and the drag block assembly 255 may then be removed from the tubular member 120.

During the radial expansion process, the expansion cone segments 225 may be raised out of the expanded portion of the tubular member 120 by applying an upward axial force to the tubular support member 215. In a preferred embodiment, during the
15 radial expansion process, the expansion cone segments 225 are raised at approximately the same rate as the tubular member 120 is expanded in order to keep the tubular member stationary relative to the new wellbore section 115. In an alternative preferred embodiment, the expansion cone segments 225 are maintained in a stationary position during the radial expansion process thereby allowing the tubular
20 member 120 to be radially expanded and plastically deformed off of the expansion cone segments 225 and into the new wellbore section 115 under the force of gravity and the operating pressure of the interior of the tubular member 120.

In a preferred embodiment, when the upper end portion of the expandable tubular member 120 and the lower portion of the wellbore casing 110 that overlap with
25 one another are plastically deformed and radially expanded by the expansion cone segments 225, the expansion cone segments 225 are displaced out of the wellbore 100 by both the operating pressure within the interior of the tubular member 120 and an upwardly directed axial force applied to the tubular support member 205.

In a preferred embodiment, the operating pressure and flow rate of the fluidic
30 material 275 is controllably ramped down when the expansion cone segments 225 reach the upper end portion of the expandable tubular member 120. In this manner, the sudden release of pressure caused by the complete radial expansion and plastic deformation of the expandable tubular member 120 off of the expansion cone segments 225 can be minimized. In a preferred embodiment, the operating pressure is
35 reduced in a substantially linear fashion from 100% to about 10% during the end of the

extrusion process beginning when the expansion cone segments 225 are within about 5 feet from completion of the extrusion process.

Alternatively, or in combination, the wall thickness of the upper end portion of the expandable tubular member 120 is tapered in order to gradually reduce the
5 required operating pressure for plastically deforming and radially expanding the upper end portion of the tubular member. In this manner, shock loading of the apparatus is at least reduced.

Alternatively, or in combination, a shock absorber is provided in the tubular support member 205 in order to absorb the shock caused by the sudden release of
10 pressure. The shock absorber may comprise, for example, any conventional commercially available shock absorber, bumper sub, or jars adapted for use in wellbore operations.

Alternatively, or in combination, an expansion cone catching structure is provided in the upper end portion of the expandable tubular member 120 in order to
15 catch or at least decelerate the expansion cone segments 225.

Alternatively, or in combination, during the radial expansion process, an upward axial force is applied to the tubular support member 215 sufficient to plastically deform and radially expand the tubular member 120 off of the external surfaces, 225bb and 225bc, of the expansion cone segments 225.

Alternatively, or in combination, in order to facilitate the pressurization of the interior 120a of the expandable tubular member by the injection of the fluidic materials 275, the region within the wellbore section 115 below the apparatus 200 may be fluidically sealed off in a convention manner using, for example, a packer.
20

Once the radial expansion process is completed, the tubular support member 205, the tubular support member 210, the tubular support member 215, the end stop 220, the expansion cone segments 225, the split ring collar 230, the drag block assembly 235, the pack cup assembly 240, the spacer 245, the packer cup assembly 250, and the drag block assembly 255 are removed from the wellbore 100.
25

In an alternative embodiment, as illustrated in Figs. 2h and 2i, the J-slots, 235d and 255e, include one or more intermediate retaining slots, 235db and 255eb,
30 respectively, that permit the relative longitudinal displacement of the tubular support member 215 relative to the drag block assemblies, 235 and 255, to be set at one or more intermediate stop positions. In this manner, the expansion segments 225 may be positioned at one or more intermediate positions on the tapered hexagonal portion
35 215gb of the expansion cone support body 215g thereby permitting the external diameter of the expansion cone segments 225 to be adjusted to one or more

intermediate sizes. In this manner, the radial expansion and plastic deformation of the expandable tubular member 120 be provided in different operation stages, each having a different expansion diameter. Furthermore, if the expansion cone segments 225 become lodged within the expandable tubular member 120, then the position of the expansion cone segments may be adjusted to provide a smaller outside diameter and the radial expansion process may be continued by injecting the fluidic material 275 and/or applying an upward axial force to the tubular support member 215.

Referring to Figs. 3 and 3a-3j, an alternative embodiment of an apparatus 300 for forming a wellbore casing in a subterranean formation will now be described. The apparatus 300 includes a tubular support member 305 defining an internal passage 305a that is coupled to an end of a tubular coupling 310 defining an internal passage 310a. The other end of the tubular coupling 310 is coupled to an end of a tubular support member 315 defining an internal passage 315a that includes a first flange 315b having oppositely tapered end-walls, 315ba and 315bb, a second flange 315c, a radial passage 315d, a third flange 315e, a fourth flange 315f, a fifth flange 315g having oppositely tapered end-walls, 315ga and 315gb, a fifth flange 315h, and an expansion cone support body 315i. The other end of the tubular support member 315 is coupled to a tubular end stop 320 that defines a passage 320a.

As illustrated in Figs. 3d and 3e, the expansion cone support body 315i includes a first end 315ia, a tapered hexagonal portion 315ib that includes a plurality of T-shaped slots 315iba provided on each of the external faceted surfaces of the tapered hexagonal portion, and a second end 315ic. In an exemplary embodiment, the angle of attack of the tapered hexagonal portion 315ib ranges from about 35 to 50 degrees for reasons to be described.

As illustrated in Figs. 3, 3a-3c, and 3f-3h, a plurality of expansion cone segments 325 are provided that include first ends 325a that include T-shaped retaining members 325aa and second ends 325b that include T-shaped retaining members 325ba that mate with and are received within corresponding T-shaped slots 315iba on the tapered hexagonal portion 315ib of the expansion cone support body 315i, first external surfaces 325bb, second external surfaces 325bc, and third external surfaces 325bd. Thus, in an exemplary embodiment, a total of six expansion cone segments 325 are provided that are slidably coupled to corresponding sides of the tapered hexagonal portion 315ib of the expansion cone support body 315i.

In an exemplary embodiment, the widths of the first external surfaces 325bb of the expansion cone segments 325 increase in the direction of the second external surfaces 325bc, the widths of the second external surfaces are substantially constant,

and the widths of the third external surfaces 325bd decrease in the direction of the first ends 325a of the expansion cone segments for reasons to be described. In an exemplary embodiment, the first external surfaces 325bb of the expansion cone segments 325 taper upwardly in the direction of the second external surfaces 325bc, the second external surfaces taper upwardly in the direction of the third external surfaces 325bd, and the third external surfaces 325bd taper downwardly in the direction of the first ends 325a of the expansion cone segments for reasons to be described. In an exemplary embodiment, the angle of attack of the taper of the first external surfaces 325bb of the expansion cone segments 325 are greater than the angle of attack of the taper of the second external surfaces 325bc. In an exemplary embodiment, the first and second external surfaces, 325bb and 325bc, of the expansion cone segments 325 are arcuate such that when the expansion cone segments 325 are displaced in the direction of the end stop 320, the first and second external surfaces of the expansion cone segments provide a substantially continuous outer circumferential surface for reasons to be described.

As illustrated in Fig. 3i, in an exemplary embodiment, the external surfaces, 325bb, 325bc, and 325bd, of the second ends 325b of the expansion cone segments 325 are adapted to mate with one another in order to interlock adjacent expansion cone segments.

A split ring collar 330 that defines a passage 330a for receiving the tubular support member 315 is provided that includes a first end that includes plurality of T-shaped slots 330b for receiving and mating with corresponding T-shaped retaining members 325aa of the expansion cone segments 325 and a second end that includes an L-shaped retaining member 330c. In an exemplary embodiment, the split ring collar 330 is a conventional split ring collar commercially available from Halliburton Energy Services modified in accordance with the teachings of the present disclosure.

A collet assembly 335 is provided that includes a support ring 335a that defines a passage 335aa for receiving the tubular support member 315 and is coupled to an end of a resilient collet 335b having upper and lower sets of oppositely tapered shoulders, 335ba and 335bb, and, 335bc and 335bd, respectively, that is positioned proximate the fourth flange 315g of the tubular support member 315. The other end of the collet 335b is coupled to an end of a tubular sleeve 335c that defines a passage 335ca. The other end of the tubular sleeve 335c is coupled to an end of a pin 335d. The other end of the pin 335d is coupled to a ring 335e that defines a passage 335ea for receiving the fifth flange 315h of the tubular support member 315. An end of a tubular coupling sleeve 335f that defines a passage 335fa for receiving the tubular

support member 315 is received within the opening 335ca of the tubular sleeve 335c that includes a recess 335fb for receiving the fifth flange 315h of the tubular support member 315 and the ring 335e, and a radial passage 335fc for receiving the pin 335d. Another end of the tubular coupling sleeve 335f includes a passage 335fd for receiving the tubular support member 315 and a slot 335fe for receiving the L-shaped retaining member 330c of the split ring collar 330. A ring 335g that defines a passage 335ga for receiving the tubular support member 315, a spring 335h, and a ring 335i that defines a passage 335ia for receiving the tubular support member 315 are also received within the recess 335fb. The ring 335g is positioned proximate one end of the recess 335fb, the ring 335i is positioned proximate the fifth flange 315h of the tubular support member 315 within the other end of the recess, and the spring 335h is positioned between the rings.

A first conventional packer cup assembly 340 that defines a passage 340a for receiving the tubular support member 315 includes a first end 340b that mates with the fourth flange 315f of the tubular support member, a conventional sealing cup 340c, and a second end 340d. A tubular spacer 345 that defines a passage 345a for receiving the tubular support member 315 includes a first end 345b that mates with the second end 340d of the first packer cup assembly 340 and a second end 345c. A second conventional packer cup assembly 350 that defines a passage 350a for receiving the tubular support member 315 includes a first end 350b that mates with the second end 345c of the spacer 345, a conventional sealing cup 350c, and a second end 350d that mates with the third flange 315e of the tubular support member.

A collet assembly 355 is provided that includes a support ring 355a that defines a passage 355aa for receiving the tubular support member 315 and is coupled to an end of a resilient collet 355b having upper and lower sets of oppositely tapered shoulders, 355ba and 355bb, and, 355bc and 355bd, respectively, that is positioned proximate the first flange 315b of the tubular support member 315. The other end of the collet 355b is coupled to an end of a tubular sleeve 355c that defines a passage 355ca. The other end of the tubular sleeve 355c is coupled to an end of a pin 355d. The other end of the pin 355d is coupled to a ring 355e that defines a passage 355ea for receiving the second flange 315c of the tubular support member 315. An end of a tubular sleeve 355f that defines a passage 355fa for receiving the tubular support member 315 is received within the opening 355ca of the tubular sleeve 355c that includes a recess 355fb for receiving the second flange 315c of the tubular support member 315 and the ring 355e, and a radial passage 355fc for receiving the pin 355d. Another end of the tubular sleeve 355f includes a passage 355fd for receiving the tubular support member

315, a recess 355fe for receiving an end of the tubular sleeve 355c, and sealing members 355ff. A ring 355g that defines a passage 355ga for receiving the tubular support member 315 and a spring 355h are also received within the recess 355fb. An end of the ring 355g is positioned proximate the second flange 315c of the tubular support member 315 within an end of the recess 355fb and the other end of the ring is positioned proximate the other end of the recess 355fb.

In an exemplary embodiment, during operation of the apparatus 300, as illustrated in Figs. 3 and 3a-3j, the apparatus may be initially positioned in the wellbore 100, within the casing 110, with the collet assemblies 335 and 355 positioned in a neutral position in which the radial passage 315d of the tubular support member 315 is not covered by the tubular sleeve 355f and the expansion cone segments 325 are not driven up the tapered hexagonal portion 315ib of the expansion cone support body 315i of the tubular support member 315 into contact with the stop member 320. In this manner, fluidic materials within the interior 315a of the tubular support member 315 may pass through the radial passage 315d into the annulus between the apparatus 300 and the casing 110 thereby preventing over pressurization of the annulus. Furthermore, in this manner, the outside diameter of the expansion cone segments 325 is less than or equal to the outside diameter of the stop member 320 thereby permitting the apparatus 300 to be displaced within the casing 110.

As illustrated in Figs. 4, and 4a-4d, the apparatus 300 may then be positioned in the tubular member 120. During the insertion of the apparatus into the tubular member 120, the upper end 120b of the tubular member may impact the tapered shoulders, 335bb and 355bb, of the collets, 335b and 355b, respectively, thereby driving the collets backward until the tapered shoulders, 335bd and 355bd, of the collets are positioned proximate the tapered shoulders, 315ga and 315ba, respectively, of the tubular support member. As a result, the support rings, 335a and 355a, the collets, 335b and 355b, the tubular sleeves, 335c and 355c, the pins, 335d and 355d, the rings, 335e and 355e, and the rings, 335g and 355g, of the collet assemblies, 335 and 355, respectively, are driven backward, compressing the springs, 335h and 355h, thereby applying axial biasing forces to the tubular coupling sleeve 335f and the tubular sleeve 355f, respectively. In this manner, an axial biasing force is applied to the split ring collar 330 and the expansion cone segments 325 that prevents the expansion cone segments from being driven up the tapered hexagonal portion 315ib of the expansion cone support body 315i of the tubular support member 315 into contact with the stop member 320. Thus, the outside diameter of the expansion cone segments

325 is maintained in a position that is less than the inside diameter of the tubular member 120 thereby permitting the apparatus 300 to be displaced within the tubular member. Furthermore, in this manner, an axial biasing force is applied to the tubular sleeve 355f thereby preventing the tubular sleeve from covering the radial passage 315d in the tubular support member 315. Thus, fluidic materials within the interior 315a of the tubular support member 315 may pass through the radial passage 315d into the annulus between the apparatus 300 and the tubular member 120 thereby preventing over pressurization of the annulus.

The apparatus 300 may then be at least partially positioned in the open hole section 115a of the wellbore section 115, beyond the lower end 120c of the tubular member 120. In an exemplary embodiment, that portion of the apparatus 300 that includes the stop member 320, the expansion cone segments 325, the split ring collar 330, the collet assembly 335, the packer cup assembly 340, the spacer 345, the packer cup assembly 350, and the collet assembly 355 is then positioned in the open hole section 115a of the wellbore section 115, beyond the lower end 120 of the tubular member for reasons to be described. Because the collets, 335b and 355b, are resilient, once the apparatus 300 has been positioned in the open hole section 115a of the wellbore section 115, beyond the lower end 120c of the tubular member 120, the tapered shoulders, 335ba and 355ba, of the collets may spring outwardly in the radial direction.

The apparatus 300 may then be repositioned at least partially back within the tubular member 120. During the re-insertion of the apparatus into the tubular member 120, the lower end 120c of the tubular member may impact the tapered shoulders, 335ba and 355ba, of the collets, 335b and 355b, respectively, thereby driving the collets forward until the tapered shoulders, 335bc and 355bc, of the collets are positioned proximate the tapered shoulders, 315gb and 315bb, respectively, of the tubular support member 315. As a result, the support rings, 335a and 355a, the collets, 335b and 355b, the tubular sleeves, 335c and 355c, the pins, 335d and 355d, the rings, 335e and 355e, the tubular coupling sleeve 335f, the tubular sleeve 355f, the rings, 335g and 355g, and the ring 335i of the collet assemblies, 335 and 355, respectively, are driven forward, thereby compressing the springs, 335h and 355h, thereby sealing off the radial passage 315d and driving the expansion cone segments 325 up the tapered hexagonal portion 315ib of the expansion cone support body 315i of the tubular support member 315 into contact with the stop member 320.

As a result, the outside diameter of the expansion cone segments 325 is now greater than the inside diameter of expandable tubular member 120 thereby permitting

the apparatus 300 to be used to radially expand and plastically deform the tubular member, and fluidic materials within the interior 315a of the tubular support member 315 may no longer pass through the radial passage 315d into the annulus between the apparatus 300 and the tubular member thereby permitting the interior of the apparatus
5 to be pressurized.

The apparatus 300 may then be operated to radially expand and plastically deform the tubular member 120 by applying an upward axial force to the tubular support member 315 and/or by injecting a pressurized fluidic material into the tubular support member.

10 In particular, as illustrated in Figs. 5 and 5a-5d, the expandable tubular member 120 may then be radially expanded using the apparatus 300 by injecting a fluidic material 275 into the apparatus through the passages 305a, 310a, 315a, and 320a. The injection of the fluidic material 275 may pressurize the interior 120a of the expandable tubular member 120. In addition, because the packer cup assemblies, 340
15 and 350, seal off an annular region 120aa below the packer cup assemblies between the expandable tubular member 120 and the tubular support member 315, the injection of the fluidic material 275 may also pressurize the annular region.

The continued injection of the fluidic material 275 may then pressurize the interior 120a of the expandable tubular member 120 thereby plastically deforming and
20 radially expanding the expandable tubular member off of the expansion cone segments 325. Because the outer surfaces, 325bb and 325bc, of the expansion cone segments 325 are tapered, the plastic deformation and radial expansion of the expandable tubular member 120 proximate the expansion cone segments is facilitated. Furthermore, in an exemplary embodiment, the continued injection of the fluidic
25 material 275 also pressurizes the annular region 120aa defined between the interior surface of the expandable tubular member 120 and the exterior surface of the tubular support member 315 that is bounded on the upper end by the packer cup assembly 340 and on the lower end by the expansion cone segments 325. Furthermore, in an exemplary embodiment, the pressurization of the annular region 120aa also radially
30 expands at least a portion of the surrounding portion of the expandable tubular member 120. In this manner, the plastic deformation and radial expansion of the expandable tubular member 120 is enhanced. Furthermore, during operation of the apparatus 300, the packer cup assemblies 340 and 350 prevent the pressurized fluidic material 275 from passing above and beyond the packer cup assemblies and thereby define the
35 length of the pressurized annular region 120aa. In an exemplary embodiment, the pressurization of the annular region 120aa decreases the operating pressures required

for plastic deformation and radial expansion of the expandable tubular member 120 by as much as 50% and also reduces the angle of attack of the tapered external surfaces, 325bb and 325bc, of the expansion cone segments 325.

5 The radial expansion of the expandable tubular member 120 may then continue until the upper end 120b of the expandable tubular member is radially expanded and plastically deformed along with the overlapping portion of the wellbore casing 110. Because the expansion cone segments 325 may be adjustable positioned from an outside diameter less than the inside diameter of the expandable tubular member 120 to an outside diameter substantially equal to the inside diameter of the pre-existing casing 110, the resulting wellbore casing, including the casing 110 and the radially expanded tubular member 120, created by the operation of the apparatus 300 may have a single substantially constant inside diameter thereby providing a mono-diameter wellbore casing.

15 During the radial expansion process, the expansion cone segments 325 may be raised out of the expanded portion of the tubular member 120 by applying an upward axial force to the tubular support member 315. In a preferred embodiment, during the radial expansion process, the expansion cone segments 325 are raised at approximately the same rate as the tubular member 120 is expanded in order to keep the tubular member stationary relative to the new wellbore section 115.

20 In a preferred embodiment, when the upper end portion of the expandable tubular member 120 and the lower portion of the wellbore casing 110 that overlap with one another are plastically deformed and radially expanded by the expansion cone segments 325, the expansion cone segments are displaced out of the wellbore 100 by both the operating pressure within the interior of the tubular member 120 and a upwardly directed axial force applied to the tubular support member 305.

25 In a preferred embodiment, the operating pressure and flow rate of the fluidic material 275 is controllably ramped down when the expansion cone segments 325 reach the upper end portion of the expandable tubular member 120. In this manner, the sudden release of pressure caused by the complete radial expansion and plastic deformation of the expandable tubular member 120 off of the expansion cone segments 325 can be minimized. In a preferred embodiment, the operating pressure is reduced in a substantially linear fashion from 100% to about 10% during the end of the extrusion process beginning when the expansion cone segments 325 are within about 5 feet from completion of the extrusion process.

35 Alternatively, or in combination, the wall thickness of the upper end portion of the expandable tubular member 120 is tapered in order to gradually reduce the

required operating pressure for plastically deforming and radially expanding the upper end portion of the tubular member. In this manner, shock loading of the apparatus is at least reduced.

Alternatively, or in combination, a shock absorber is provided in the tubular support member 305 in order to absorb the shock caused by the sudden release of pressure. The shock absorber may comprise, for example, any conventional commercially available shock absorber, bumper sub, or jars adapted for use in wellbore operations.

Alternatively, or in combination, an expansion cone catching structure is provided in the upper end portion of the expandable tubular member 120 in order to catch or at least decelerate the expansion cone segments 325.

Alternatively, or in combination, during the radial expansion process, an upward axial force is applied to the tubular support member 315 sufficient to plastically deform and radially expand the tubular member 120 off of the external surfaces, 225bb and 225bc, of the expansion cone segments 325.

Alternatively, or in combination, in order to facilitate the pressurization of the interior 120a of the expandable tubular member by the injection of the fluidic materials 275, the region within the wellbore section 115 below the apparatus 300 may be fluidically sealed off in a convention manner using, for example, a packer.

Once the radial expansion process is completed, the tubular support member 305, the tubular support member 310, the tubular support member 315, the end stop 320, the expansion cone segments 325, the split ring collar 330, the collet assembly 335, the packer cup assembly 340, the spacer 345, the packer cup assembly 350, and the collet assembly 355 are removed from the wellbores 100 and 115.

Referring to Figs. 6 and 6a-6k, an alternative embodiment of an apparatus 400 for forming a wellbore casing in a subterranean formation will now be described. The apparatus 400 includes a tubular support member 405 defining an internal passage 405a that is coupled to an end of a tubular coupling 410 defining an internal passage 410a. The other end of the tubular coupling 410 is coupled to an end of a tubular support member 415 defining an internal passage 415a that includes a first flange 415b, a first radial passage 415c, a second radial passage 415d, a second flange 415e, a stepped flange 415f, a third flange 415g, a fourth flange 415h, a fifth flange 415i, and an expansion cone body 415j. The other end of the tubular support member 415 is coupled to a tubular end stop 420 that defines a passage 420a.

As illustrated in Figs. 6e and 6f, the expansion cone support body 415j includes a first end 415ja, a tapered hexagonal portion 415jb that includes a plurality of T-

shaped slots 415jba provided on each of the external faceted surfaces of the tapered hexagonal portion, and a second end 415jc. In an exemplary embodiment, the angle of attack of the tapered hexagonal portion 415jb ranges from about 35 to 50 degrees for reasons to be described.

5 As illustrated in Figs. 6, 6a-6d, and 6g-6i, a plurality of expansion cone segments 425 are provided that include first ends 425a that include T-shaped retaining members 425aa and second ends 425b that include T-shaped retaining members 425ba that mate with and are received within corresponding T-shaped slots 415jba on the tapered hexagonal portion 415jb of the expansion cone support body 415j, first
10 external surfaces 425bb, second external surfaces 425bc, and third external surfaces 425bd. Thus, in an exemplary embodiment, a total of six expansion cone segments 425 are provided that are slidably coupled to corresponding sides of the tapered hexagonal portion 415jb of the expansion cone support body 415j.

 In an exemplary embodiment, the widths of the first external surfaces 425bb of
15 the expansion cone segments 425 increase in the direction of the second external surfaces 425bc, the widths of the second external surfaces are substantially constant, and the widths of the third external surfaces 425bd decrease in the direction of the first ends 425a of the expansion cone segments for reasons to be described. In an exemplary embodiment, the first external surfaces 425bb of the expansion cone
20 segments 425 taper upwardly in the direction of the second external surfaces 425bc, the second external surfaces taper upwardly in the direction of the third external surfaces 425bd, and the third external surfaces 425bd taper downwardly in the direction of the first ends 425a of the expansion cone segments for reasons to be described. In an exemplary embodiment, the angle of attack of the taper of the first
25 external surfaces 425bb of the expansion cone segments 425 are greater than the angle of attack of the taper of the second external surfaces 425bc. In an exemplary embodiment, the first and second external surfaces, 425bb and 425bc, of the expansion cone segments 425 are arcuate such that when the expansion cone segments 425 are displaced in the direction of the end stop 420, the first and second
30 external surfaces of the expansion cone segments provide a substantially continuous outer circumferential surface for reasons to be described.

 As illustrated in Fig. 6j, in an exemplary embodiment, the external surfaces, 425bb, 425bc, and 425bd, of the second ends 425b of the expansion cone segments 425 are adapted to mate with one another in order to interlock adjacent expansion
35 cone segments.

A split ring collar 430 that defines a passage 430a for receiving the tubular support member 415 is provided that includes a first end that includes plurality of T-shaped slots 430b for receiving and mating with corresponding T-shaped retaining members 425aa of the expansion cone segments 425 and a second end that includes an L-shaped retaining member 430c. In an exemplary embodiment, the split ring collar 430 is a conventional split ring collar commercially available from Halliburton Energy Services modified in accordance with the teachings of the present disclosure.

A dog assembly 435 is provided that includes a tubular sleeve 435a that defines a passage 435aa for receiving the tubular support member 415 that includes a first end that includes a slot 435ab for receiving and mating with the L-shaped retaining member 430c of the split ring collar 430, a radial passage 435ac, and a recess 435ad for receiving the fifth flange 415a of the tubular support member 415. A second end of the tubular sleeve 435a includes a flange 435ae that mates with the fourth flange 415h of the tubular support member 415. A retaining ring 435b that defines a passage 435ba for receiving the fifth flange 415i is received within the recess 435ad of the tubular sleeve 435a and is coupled to an end of a load transfer pin 435c. The opposite end of the load transfer pin 435c is received within the radial passage 435ac of the tubular sleeve 435a and is coupled to an end of a tubular sleeve 435d that includes a recess 435da at a first end for receiving the tubular sleeve 435a, and a radial opening 435dc for receiving a conventional resilient dog 435e. A spring 435f and a ring 435g that defines a passage 435ga for receiving the tubular support member 415 are received within the recess 435ad of the tubular sleeve 435a between a first end of the recess and the fifth flange 415i of the tubular support member.

A first conventional packer cup assembly 440 that defines a passage 440a for receiving the tubular support member 415 includes a first end 440b that mates with the fourth flange 415g of the tubular support member, a conventional sealing cup 440c, and a second end 440d. A tubular spacer 445 that defines a passage 445a for receiving the tubular support member 415 includes a first end 445b that mates with the second end 440d of the first packer cup assembly 440 and a second end 445c. A second conventional packer cup assembly 450 that defines a passage 450a for receiving the tubular support member 415 includes a first end 450b that mates with the second end 445c of the spacer 445, a conventional sealing cup 450c, and a second end 450d that mates with the stepped flange 415f of the tubular support member.

A dog assembly 455 is provided that includes a tubular sleeve 455a that defines a passage 455aa for receiving the tubular support member 415. A first end of the tubular sleeve 455a includes a radial opening 455ab for receiving a conventional

resilient dog 455b. A second end of the tubular sleeve 455a includes a recess 455ac and is coupled to an end of a load transfer pin 455c. The opposite end of the load transfer pin 455c is coupled to a retaining ring 455d that defines a passage 455da for receiving the tubular support member 415. A tubular sleeve 455e is received within the
5 recess 455ac of the tubular sleeve 455a that defines a passage 455ea for receiving the tubular support member 415 and includes a first end that includes a radial passage 455eb for receiving the load transfer pin 455c and a recess 455ec for receiving a spring 455f. A ring 455g that defines a passage 455ga for receiving the tubular support member 415 is further received within the recess 455ec of the tubular sleeve 455e
10 between the spring 455f and the second flange 415e of the tubular support member 415. A second end of the tubular sleeve 455e includes a radial passage 455ed, sealing members, 455ef and 455eg, and a recess 455eh that mates with the first flange 415b of the tubular support member 415.

In an exemplary embodiment, during operation of the apparatus 400, as
15 illustrated in Figs. 6 and 6a-6k, the apparatus may be initially positioned in the wellbore 100, within the casing 110, with the dog assemblies 435 and 455 positioned in a neutral position in which the radial passage 415d of the tubular support member 415 is fluidically coupled to the radial passage 455ed of the dog assembly 455 and the expansion cone segments 425 are not driven up the tapered hexagonal portion 415jb
20 of the expansion cone support body 415j of the tubular support member 415 into contact with the stop member 320. In this manner, fluidic materials within the interior 415a of the tubular support member 415 may pass through the radial passages, 415d and 455ed, into the annulus between the apparatus 400 and the casing 110 thereby preventing over pressurization of the annulus. Furthermore, in this manner, the outside
25 diameter of the expansion cone segments 425 is less than or equal to the outside diameter of the stop member 420 thereby permitting the apparatus 400 to be displaced within the casing 110.

As illustrated in Figs. 7, and 7a-7c, the apparatus 400 may then be positioned in the tubular member 120. During the insertion of the apparatus into the tubular member
30 120, the upper end 120b of the tubular member may impact the ends of the resilient dogs, 435e and 455b, of the dog assemblies, 435 and 455, respectively, thereby driving the resilient dogs, 435e and 455b, backwards off of and adjacent to one side of the flanges, 415h and 415f, respectively. As a result of the backward axial displacement of the resilient dog 435e, the tubular sleeve 435d, the pin 435c, the
35 retaining ring 435b, and the ring 435g of the dog assembly 435 are driven backward thereby compressing the spring 435f and applying an axial biasing force to the tubular

sleeve 435a that prevents the expansion cone segments 425 from being displaced toward the end stop 420. As a result of the backward axial displacement of the resilient dog 455b, the tubular sleeve 455a, the pin 455c, the retaining ring 455d, and the ring 455g of the dog assembly 455 are driven backward thereby compressing the spring 455f and applying an axial biasing force to the tubular sleeve 455e that prevents the radial passages, 415d and 455ed from being fluidically decoupled.

The apparatus 400 may then be at least partially positioned in the open hole section 115a of the wellbore section 115, beyond the lower end 120c of the tubular member 120. In an exemplary embodiment, that portion of the apparatus 400 that includes the stop member 420, the expansion cone segments 425, the split ring collar 430, the dog assembly 435, the packer cup assembly 440, the spacer 445, the packer cup assembly 450, and the dog assembly 455 is then positioned in the open hole section 115a of the wellbore section 115, beyond the lower end 120 of the tubular member for reasons to be described. Because the dogs, 435e and 455b, of the dog assemblies, 435 and 455, respectively, are resilient, once the apparatus 400 has been positioned in the open hole section 115a of the wellbore section 115, beyond the lower end 120c of the tubular member 120, the resilient dogs, 435e and 455b, of the dog assemblies may spring outwardly in the radial direction.

The apparatus 400 may then be repositioned at least partially back within the tubular member 120. During the re-insertion of the apparatus into the tubular member 120, the lower end 120c of the tubular member may impact the ends of the resilient dogs, 435e and 455b, of the dog assemblies, 435 and 455, respectively, thereby driving the resilient dogs forward until the resilient dogs are positioned beyond and adjacent to the other side of the flanges, 415h and 415f, of the tubular support member 415.

As a result, of the forward axial displacement of the resilient dog 435e, the tubular sleeve 435a, the retaining ring 435b, the pin 435c, the tubular sleeve 435d, the spring 435f, and the ring 435g of the dog assembly 435 are displaced in the forward axial direction thereby also displacing the split ring collar 430 and the expansion cone segments 425 in the forward axial direction. As a result, the expansion cone segments 425 are driven up the tapered hexagonal portion 415jb of the expansion cone support body 415j of the tubular support member 415 into contact with the stop member 320.

As a result of the forward axial displacement of the resilient dog 455b, the tubular sleeve 455a, the pin 455c, the retaining ring 455d, the tubular sleeve 455e, the spring 455f, and the ring 455g of the dog assembly 455 are driven forward in the axial direction thereby fluidically decoupling the radial passages, 415d and 455ed, and fluidically

coupling the radial passages 415c and 415d. As a result fluidic materials within the tubular support member 415 may not pass into the annulus between the tubular support member and the tubular member 120.

As a result of the forward axial displacement of the resilient dog 435e, the
5 outside diameter of the expansion cone segments 425 is now greater than the inside diameter of expandable tubular member 120 thereby permitting the apparatus 400 to be used to radially expand and plastically deform the tubular member, and fluidic materials within the interior 415a of the tubular support member 415 may no longer pass through the radial passages, 415d and 455ed, into the annulus between the
10 apparatus 400 and the tubular member thereby permitting the interior of the apparatus to be pressurized.

The apparatus 400 may then be operated to radially expand and plastically deform the tubular member 120 by applying an upward axial force to the tubular support member 415 and/or by injecting a pressurized fluidic material into the tubular
15 support member.

In particular, as illustrated in Figs. 8 and 8a-8d, the expandable tubular member 120 may then be radially expanded using the apparatus 400 by injecting a fluidic material 275 into the apparatus through the passages 405a, 310a, 415a, and 420a. The injection of the fluidic material 275 may pressurize the interior 120a of the
20 expandable tubular member 120. In addition, because the packer cup assemblies, 440 and 450, seal off an annular region 120aa below the packer cup assemblies between the expandable tubular member 120 and the tubular support member 415, the injection of the fluidic material 275 may also pressurize the annular region.

The continued injection of the fluidic material 275 may then pressurize the
25 interior 120a of the expandable tubular member 120 thereby plastically deforming and radially expanding the expandable tubular member off of the expansion cone segments 425. Because the outer surfaces, 425bb and 425bc, of the expansion cone segments 425 are tapered, the plastic deformation and radial expansion of the expandable tubular member 120 proximate the expansion cone segments is facilitated.

Furthermore, in an exemplary embodiment, the continued injection of the fluidic
30 material 275 also pressurizes the annular region 120aa defined between the interior surface of the expandable tubular member 120 and the exterior surface of the tubular support member 415 that is bounded on the upper end by the packer cup assembly 440 and on the lower end by the expansion cone segments 425. Furthermore, in an
35 exemplary embodiment, the pressurization of the annular region 120aa also radially expands at least a portion of the surrounding portion of the expandable tubular member

120. In this manner, the plastic deformation and radial expansion of the expandable tubular member 120 is enhanced. Furthermore, during operation of the apparatus 300, the packer cup assemblies 440 and 450 prevent the pressurized fluidic material 275 from passing above and beyond the packer cup assemblies and thereby define the length of the pressurized annular region 120aa. In an exemplary embodiment, the pressurization of the annular region 120aa decreases the operating pressures required for plastic deformation and radial expansion of the expandable tubular member 120 by as much as 50% and also reduces the angle of attack of the tapered external surfaces, 425bb and 425bc, of the expansion cone segments 425.

10 The radial expansion of the expandable tubular member 120 may then continue until the upper end 120b of the expandable tubular member is radially expanded and plastically deformed along with the overlapping portion of the wellbore casing 110. Because the expansion cone segments 425 may be adjustably positioned from an outside diameter less than the inside diameter of the expandable tubular member 120 to an outside diameter substantially equal to the inside diameter of the pre-existing casing 110, the resulting wellbore casing, including the casing 110 and the radially expanded tubular member 120, created by the operation of the apparatus 400 may have a single substantially constant inside diameter thereby providing a mono-diameter wellbore casing.

20 During the radial expansion process, the expansion cone segments 425 may be raised out of the expanded portion of the tubular member 120 by applying an upward axial force to the tubular support member 415. In a preferred embodiment, during the radial expansion process, the expansion cone segments 425 are raised at approximately the same rate as the tubular member 120 is expanded in order to keep the tubular member stationary relative to the new wellbore section 115.

25 In a preferred embodiment, when the upper end portion of the expandable tubular member 120 and the lower portion of the wellbore casing 110 that overlap with one another are plastically deformed and radially expanded by the expansion cone segments 425, the expansion cone segments are displaced out of the wellbore 100 by both the operating pressure within the interior of the tubular member 120 and a upwardly directed axial force applied to the tubular support member 405.

30 In a preferred embodiment, the operating pressure and flow rate of the fluidic material 275 is controllably ramped down when the expansion cone segments 425 reach the upper end portion of the expandable tubular member 120. In this manner, the sudden release of pressure caused by the complete radial expansion and plastic deformation of the expandable tubular member 120 off of the expansion cone

35

segments 425 can be minimized. In a preferred embodiment, the operating pressure is reduced in a substantially linear fashion from 100% to about 10% during the end of the extrusion process beginning when the expansion cone segments 425 are within about 5 feet from completion of the extrusion process.

5 Alternatively, or in combination, the wall thickness of the upper end portion of the expandable tubular member 120 is tapered in order to gradually reduce the required operating pressure for plastically deforming and radially expanding the upper end portion of the tubular member. In this manner, shock loading of the apparatus is at least reduced.

10 Alternatively, or in combination, a shock absorber is provided in the tubular support member 405 in order to absorb the shock caused by the sudden release of pressure. The shock absorber may comprise, for example, any conventional commercially available shock absorber, bumper sub, or jars adapted for use in wellbore operations.

15 Alternatively, or in combination, an expansion cone catching structure is provided in the upper end portion of the expandable tubular member 120 in order to catch or at least decelerate the expansion cone segments 425.

 Alternatively, or in combination, during the radial expansion process, an upward axial force is applied to the tubular support member 415 sufficient to plastically deform and radially expand the tubular member 120 off of the external surfaces, 225bb and 225bc, of the expansion cone segments 425.

20 Alternatively, or in combination, in order to facilitate the pressurization of the interior 120a of the expandable tubular member by the injection of the fluidic materials 275, the region within the wellbore section 115 below the apparatus 400 may be fluidically sealed off in a convention manner using, for example, a packer.

25 Once the radial expansion process is completed, the tubular support member 405, the tubular support member 410, the tubular support member 415, the end stop 420, the expansion cone segments 425, the split ring collar 430, the dog assembly 435, the packer cup assembly 440, the spacer 445, the packer cup assembly 450, and the dog assembly 455 are removed from the wellbores 100 and 115.

30 Referring now to Figs. 9, 9a, 10 and 10a, an embodiment of an adjustable expansion cone assembly 500 will be described. The assembly 500 includes a tubular support member 505 that defines a passage 505a and includes a flange 505b, an expansion cone support flange assembly 505c, and an end stop 505d. The expansion cone support flange assembly 505c includes a tubular body 505ca and a plurality of
35 equally spaced apart expansion cone segment support members 505cb that extend

outwardly from the tubular body in the radial direction that each include identical bases 505cba and extensions 505cbb. The support members 505cb further include first sections 505cbc having arcuate conical outer surfaces and second sections 505cbd having arcuate cylindrical outer surfaces for reasons to be described.

5 An expansion cone segment assembly 510 is provided that includes a tubular support 510a defining a passage 510aa for receiving the tubular support member 505 and a slot 510ab. A plurality of spaced apart and substantially identical resilient expansion cone segment collets 510b extend from the tubular support 510a in the axial direction that include expansion cone segments 510ba extending therefrom in the axial
10 direction. Each of the expansion cone segments 510ba further include arcuate conical expansion surfaces 510baa for radially expanding an expandable tubular member.

 A split ring collar 515 is provided that defines a passage 515a for receiving the tubular support member 505 that includes an L-shaped retaining member 515b at one end for mating with the slot 510ab of the tubular support 510a of the expansion cone
15 segment assembly 510. Another end of the split ring collar 515 includes an L-shaped retaining member 515c. A tubular sleeve 520 is provided that defines a passage 520a for receiving the tubular support member 505 that includes a slot 520b for receiving the L-shaped retaining member 515c of the split ring collar 515.

 During operation of the assembly 500, as illustrated in Figs. 9 and 9a, in an
20 unexpanded position, the expansion cone segments 510ba of the expansion cone segment assembly 510 are positioned adjacent to the base of the conical section 505cbc of the expansion cone segment support members 505cb with the outside diameter of the expansion cone segments less than or equal to the maximum outside diameter of the assembly. As illustrated in Figs. 10 and 10a, the assembly 500 may
25 then be expanded by displacing the tubular sleeve 520, the split ring collar 515, and the expansion cone segment assembly 510 in the axial direction towards the expansion cone segment support members 505cb. As a result, the expansion cone segments 510ba are driven up the conical section 505cbc of the expansion cone segment support members 505cb and then onto the cylindrical section 505cbd of the expansion
30 cone segment support members until the expansion cone segments impact the end stop 505d. In this manner, the outside diameter of the expansion segments 510ba is greater than the maximum diameter of the remaining components of the assembly 500. Furthermore, the conical outer surfaces 510baa of the expansion cone segments 510ba may now be used to radially expand a tubular member. Note that the
35 extensions 505cbb of the expansion cone segment support members 505cb provide support in the circumferential direction to the adjacent expansion cone segments

510ba. In an exemplary embodiment, the outer conical surfaces 510baa of the expansion cone segments 510ba in the expanded position of the assembly 500 provide a substantially continuous outer conical surfaces in the circumferential direction.

The assembly 500 may then be returned to the unexpanded position by
5 displacing the tubular sleeve 520, the split ring collar 515, and the expansion cone segment assembly 510 in the axial direction away from the expansion cone segment support members 505cb. As a result, the expansion cone segments 510ba are displaced off of the cylindrical section 505cbd and the conical section 505cbc of the expansion cone segment support members 505cb. Because the collets 510b of the
10 expansion cone segment assembly 510 are resilient, the expansion segments 510ba are thereby returned to a position in which the outside diameter of the expansion cone segments is less than or equal to the maximum diameter of the remaining components of the assembly 500.

In several alternative embodiments, the assembly 500 is incorporated into the
15 assemblies 200, 300 and/or 400.

Referring now to Figs. 11, 11a, 12 and 12a, an embodiment of an adjustable expansion cone assembly 600 will be described. The assembly 600 includes a tubular support member 605 that defines a passage 605a and includes an expansion cone support flange assembly 605b, and an end stop 605c. The expansion cone support
20 flange assembly 605b includes a tubular body 605ba and a plurality of equally spaced apart expansion cone segment substantially identical support members 605bb that extend outwardly from the tubular body in the radial direction. The support members 605bb further include first sections 605bba having arcuate cylindrical outer surfaces, second sections 605bbb having arcuate conical outer surfaces, and third sections
25 605bbc having arcuate cylindrical outer surfaces for reasons to be described.

An expansion cone segment assembly 610 is provided that includes a tubular support 610a defining a passage 610aa for receiving the tubular support member 605 and a slot 610ab. A plurality of spaced apart and substantially identical resilient expansion cone segment collets 610b extend from the tubular support 610a in the axial
30 direction that include expansion cone segments 610ba extending therefrom in the axial direction. Each of the expansion cone segments 610ba further include arcuate conical expansion surfaces 610baa for radially expanding an expandable tubular member.

A split ring collar 615 is provided that defines a passage 615a for receiving the tubular support member 605 that includes an L-shaped retaining member 615b at one
35 end for mating with the slot 610ab of the tubular support 610a of the expansion cone segment assembly 610. Another end of the split ring collar 615 includes an L-shaped

retaining member 615c. A tubular sleeve 620 is provided that defines a passage 620a for receiving the tubular support member 605 that includes a slot 620b for receiving the L-shaped retaining member 615c of the split ring collar 615.

During operation of the assembly 600, as illustrated in Figs. 11 and 11a, in an unexpanded position, the expansion cone segments 610ba of the expansion cone segment assembly 610 are positioned on the cylindrical section 605bba, adjacent to the base of the conical section 605bbb, of the expansion cone segment support members 605bb with the outside diameter of the expansion cone segments less than or equal to the maximum outside diameter of the assembly. As illustrated in Figs. 12 and 12a, the assembly 600 may then be expanded by displacing the tubular sleeve 620, the split ring collar 615, and the expansion cone segment assembly 610 in the axial direction towards the expansion cone segment support members 605bb. As a result, the expansion cone segments 610ba are driven up the conical section 605bbb of the expansion cone segment support members 605bb and then onto the cylindrical section 605bbc of the expansion cone segment support members until the expansion cone segments impact the end stop 605c. In this manner, the outside diameter of the expansion segments 610ba is greater than the maximum diameter of the remaining components of the assembly 600. Furthermore, the conical outer surfaces 610baa of the expansion cone segments 610ba may now be used to radially expand a tubular member. In an exemplary embodiment, the outer conical surfaces 610baa of the expansion cone segments 610ba in the expanded position of the assembly 600 provide a substantially continuous outer conical surfaces in the circumferential direction.

The assembly 600 may then be returned to the unexpanded position by displacing the tubular sleeve 620, the split ring collar 615, and the expansion cone segment assembly 610 in the axial direction away from the expansion cone segment support members 605bb. As a result, the expansion cone segments 610ba are displaced off of the cylindrical section 605bbc and the conical section 605bbb and back onto the cylindrical section 605bba of the expansion cone segment support members 605bb. Because the collets 610b of the expansion cone segment assembly 610 are resilient, the expansion segments 610ba are thereby returned to a position in which the outside diameter of the expansion cone segments is less than or equal to the maximum diameter of the remaining components of the assembly 600.

In several alternative embodiments, the assembly 600 is incorporated into the assemblies 200, 300 and/or 400.

Referring now to Figs. 13, 13a, 13b, 13c, 14 and 14a, an embodiment of an adjustable expansion cone assembly 700 will be described. The assembly 700

includes a tubular support member 705 that defines a passage 705a and includes an expansion cone support flange assembly 705b, and an end stop 705c. The expansion cone support flange assembly 705b includes a tubular body 705ba and a plurality of equally spaced apart expansion cone segment substantially identical support members 705bb that extend outwardly from the tubular body in the radial direction. The support members 705bb further include first sections 705bba having arcuate cylindrical outer surfaces, second sections 705bbb having arcuate conical outer surfaces, and third sections 705bbc having arcuate cylindrical outer surfaces for reasons to be described.

An expansion cone segment assembly 710 is provided that includes a first tubular support 710a defining a passage 710aa for receiving the tubular support member 705 that includes a slot 710ab and a second tubular support 710b defining a passage 710ba for receiving the tubular support member 705 that includes a plurality of spaced apart and substantially identical axial slots 710bb. A plurality of spaced apart and substantially identical resilient expansion cone segment collets 710ac extend from the first tubular support 710a in the axial direction and are received within corresponding ones of the axial slots 710bb in the second tubular support 710b that include substantially identical expansion cone segments 710aca extending therefrom in the axial direction. A plurality of spaced apart and substantially identical resilient expansion cone segment collets 710bc extend from the second tubular support 710b in the axial direction that are interleaved and overlap with the expansion cone segment collets 710ac and that include substantially identical expansion cone segments 710bca extending therefrom in the axial direction. Each of the expansion cone segments, 710aca and 710bca, further include arcuate conical expansion surfaces, 710acaa and 710bcaa, respectively, for radially expanding an expandable tubular member. A plurality of pins 715a-715d couple the expansion cone segment collets 710ac to the second tubular support 710b.

A split ring collar 720 is provided that defines a passage 720a for receiving the tubular support member 705 that includes an L-shaped retaining member 720b at one end for mating with the slot 710ab of the first tubular support 710a of the expansion cone segment assembly 710. Another end of the split ring collar 720 includes an L-shaped retaining member 720c. A tubular sleeve 725 is provided that defines a passage 725a for receiving the tubular support member 705 that includes a slot 725b for receiving the L-shaped retaining member 720c of the split ring collar 720.

During operation of the assembly 700, as illustrated in Figs. 13, 13a, 13b, and 13c, in an unexpanded position, the expansion cone segments 710aca of the expansion cone segment assembly 710 overlap with and are positioned over the

expansion cone segments 710bca of the expansion cone segment assembly, adjacent to the base of the conical section 705bbb, of the expansion cone segment support members 705bb with the outside diameter of the expansion cone segments less than or equal to the maximum outside diameter of the assembly. As illustrated in Figs. 14 and 14a, the assembly 700 may then be expanded by displacing the tubular sleeve 725, the split ring collar 720, and the expansion cone segment assembly 710 in the axial direction towards the expansion cone segment support members 705bb. As a result, the expansion cone segments, 710aca and 710bca, are driven up the conical section 705bbb of the expansion cone segment support members 705bb and then onto the cylindrical section 705bbc of the expansion cone segment support members until the expansion cone segments impact the end stop 705c. In this manner, the outside diameter of the expansion segments, 710aca and 710bca, is greater than the maximum diameter of the remaining components of the assembly 700. Furthermore, the conical outer surfaces, 710acaa and 710bcaa, of the expansion cone segments, 710aca and 710bca, respectively, may now be used to radially expand a tubular member. In an exemplary embodiment, the outer conical surfaces, 710acaa and 710bcaa, of the expansion cone segments, 710aca and 710bca, respectively, in the expanded position of the assembly 700 provide a substantially continuous outer conical surfaces in the circumferential direction.

The assembly 700 may then be returned to the unexpanded position by displacing the tubular sleeve 720, the split ring collar 715, and the expansion cone segment assembly 710 in the axial direction away from the expansion cone segment support members 705bb. As a result, the expansion cone segments, 710aca and 710bca, are displaced off of the cylindrical section 705bbc and the conical section 705bbb and back onto the cylindrical section 705bba of the expansion cone segment support members 705bb. Because the collets, 710ac and 710bc, of the expansion cone segment assembly 710 are resilient, the expansion segments, 710aca and 710bca, are thereby returned to a position in which the outside diameter of the expansion cone segments is less than or equal to the maximum diameter of the remaining components of the assembly 700.

In several alternative embodiments, the assembly 700 is incorporated into the assemblies 200, 300 and/or 400.

Referring to Figs. 15 and 15a-15j, an alternative embodiment of an apparatus 800 for forming a wellbore casing in a subterranean formation will now be described. The apparatus 800 includes a tubular support member 805 defining an internal passage 805a that is coupled to an end of a tubular coupling 810 defining an internal

passage 810a. The other end of the tubular coupling 810 is coupled to an end of a tubular support member 815 defining an internal passage 815a having a throat passage 815aa that includes a first radial passage 815b, a first flange 815c having a second radial passage 815d, a second flange 815e having opposite shoulders, 815ea and 815eb, a third flange 815f, and an expansion cone support body 815g. The other end of the tubular support member 815 is coupled to a tubular end stop 820 that defines a passage 820a.

As illustrated in Figs. 15d and 15e, the expansion cone support body 815g includes a first end 815ga, a tapered hexagonal portion 815gb that includes a plurality of T-shaped slots 815gba provided on each of the external faceted surfaces of the tapered hexagonal portion, and a second end 815gc. In an exemplary embodiment, the angle of attack of the tapered hexagonal portion 815gb ranges from about 35 to 50 degrees for reasons to be described.

As illustrated in Figs. 15, 15a-15c, and 15f-15j, a plurality of expansion cone segments 825 are provided that include first ends 825a that include T-shaped retaining members 825aa and second ends 825b that include T-shaped retaining members 825ba that mate with and are received within corresponding T-shaped slots 815gba on the tapered hexagonal portion 815gb of the expansion cone support body 815g, first external surfaces 825bb, second external surfaces 825bc, and third external surfaces 825bd. Thus, in an exemplary embodiment, a total of six expansion cone segments 825 are provided that are slidably coupled to corresponding sides of the tapered hexagonal portion 815gb of the expansion cone support body 815g.

In an exemplary embodiment, the widths of the first external surfaces 825bb of the expansion cone segments 825 increase in the direction of the second external surfaces 825bc, the widths of the second external surfaces are substantially constant, and the widths of the third external surfaces 825bd decrease in the direction of the first ends 825a of the expansion cone segments for reasons to be described. In an exemplary embodiment, the first external surfaces 825bb of the expansion cone segments 825 taper upwardly in the direction of the second external surfaces 825bc, the second external surfaces taper upwardly in the direction of the third external surfaces 825bd, and the third external surfaces 825bd taper downwardly in the direction of the first ends 825a of the expansion cone segments for reasons to be described. In an exemplary embodiment, the angle of attack of the taper of the first external surfaces 825bb of the expansion cone segments 825 are greater than the angle of attack of the taper of the second external surfaces 825bc. In an exemplary embodiment, the first and second external surfaces, 825bb and 825bc, of the

expansion cone segments 825 are arcuate such that when the expansion cone segments 825 are displaced in the direction of the end stop 420, the first and second external surfaces of the expansion cone segments provide a substantially continuous outer circumferential surface for reasons to be described.

5 As illustrated in Fig. 15i, in an exemplary embodiment, the external surfaces, 825bb, 825bc, and 825bd, of the second ends 825b of the expansion cone segments 825 are adapted to mate with one another in order to interlock adjacent expansion cone segments.

A split ring collar 830 that defines a passage 830a for receiving the tubular support member 815 is provided that includes a first end that includes plurality of T-shaped slots 830b for receiving and mating with corresponding T-shaped retaining members 825aa of the expansion cone segments 825 and a second end that includes an L-shaped retaining member 830c. In an exemplary embodiment, the split ring collar 830 is a conventional split ring collar commercially available from Halliburton Energy Services modified in accordance with the teachings of the present disclosure.

10 A dog assembly 835 is provided that includes a tubular sleeve 835a that defines a passage 835aa for receiving the tubular support member 815 and includes a slot 835ab for receiving and mating with the L-shaped retaining member 830c of the split ring collar 830, a counterbore 835ac, and a radial passage 835ad. An end of a load transfer pin 835b passes through the radial passage 835ad and is coupled to a retaining ring 835c that defines a passage 835ca for receiving the flange 815f of the tubular support member 815 and is received within the counterbore 835ac of the tubular sleeve. A ring 835d that defines a passage 835da for receiving the tubular support member 815 and a spring 835e are also received within the counterbore 835ac of the tubular sleeve 835a between the flange 815f and the end of the counterbore. The other end of the load transfer pin 835b is coupled to an end of a tubular sleeve 835f that includes a counterbore 835fa for receiving the tubular sleeve 835a, a radial passage 835fb for receiving a conventional resilient dog 835g, a counterbore 835fc for receiving and mating with the flange 815e of the tubular support member 815, a flange 835fd, and a flange 835fe including counterbores, 835ff and 835fg, that mate with and receive the flange 815c of the tubular support member, and a radial passage 835fh.

A first conventional packer cup assembly 840 that defines a passage 440a for receiving the tubular sleeve 835f includes a first end 840b that mates with the flange 835fd of the tubular sleeve 835f, a conventional sealing cup 840c, and a second end 840d. A tubular spacer 845 that defines a passage 845a for receiving the tubular sleeve 835f includes a first end 845b that mates with the second end 840d of the first

packer cup assembly 840 and a second end 845c. A second conventional packer cup assembly 850 that defines a passage 850a for receiving the tubular sleeve 835f includes a first end 850b that mates with the second end 845c of the spacer 845, a conventional sealing cup 850c, and a second end 850d that mates with the flange 835fe of the tubular sleeve.

In an exemplary embodiment, during operation of the apparatus 800, as illustrated in Figs. 15 and 15a-15j, the apparatus may be initially positioned in the wellbore 100, within the casing 110, with the dog assembly 835 positioned in a neutral position in which the radial passage 815d of the tubular support member 815 is fluidically coupled to the radial passage 835fh of the dog assembly 835 and the expansion cone segments 825 are not driven up the tapered hexagonal portion 815gb of the expansion cone support body 815g of the tubular support member 815 into contact with the stop member 320. In this manner, fluidic materials within the interior 815a of the tubular support member 815 may pass through the radial passages, 815d and 835fh, into the annulus between the apparatus 800 and the casing 110 thereby preventing over pressurization of the annulus. Furthermore, in this manner, the outside diameter of the expansion cone segments 825 is less than or equal to the outside diameter of the stop member 820 thereby permitting the apparatus 800 to be displaced within the casing 110.

As illustrated in Figs. 16, and 16a-16c, the apparatus 800 may then be positioned in the tubular member 120. During the insertion of the apparatus into the tubular member 120, the upper end 120b of the tubular member may impact the end of the resilient dog 835g of the dog assembly 835 thereby driving the resilient dog 835g backwards onto the shoulder 815ea of the flange 815e of the tubular support member 815. As a result of the backward axial displacement of the resilient dog 835g, the tubular sleeve 835f, the pin 835b, the retaining ring 835c, the ring 835d, and the spring 835e of the dog assembly 835 are driven backward thereby compressing the spring 835e and applying an axial biasing force to the tubular sleeve 835a that prevents the expansion cone segments 825 from being displaced toward the end stop 820.

The apparatus 800 may then be at least partially positioned in the open hole section 115a of the wellbore section 115, beyond the lower end 120c of the tubular member 120. In an exemplary embodiment, that portion of the apparatus 800 that includes the stop member 820, the expansion cone segments 825, the split ring collar 830, and the dog assembly 835 is then positioned in the open hole section 115a of the wellbore section 115, beyond the lower end 120 of the tubular member for reasons to be described. Because the dog 835g of the dog assembly 835 is resilient, once the

apparatus 800 has been positioned in the open hole section 115a of the wellbore section 115, beyond the lower end 120c of the tubular member 120, the resilient dog of the dog assembly may spring outwardly in the radial direction.

5 The apparatus 800 may then be repositioned at least partially back within the tubular member 120. During the re-insertion of the apparatus into the tubular member 120, the lower end 120c of the tubular member may impact the ends of the resilient dog 835g of the dog assembly 835 thereby driving the resilient dog forward until the resilient dog is positioned onto the shoulder 815eb of the flange 815e of the tubular support member 815.

10 As a result of the forward axial displacement of the resilient dog 835g, the tubular sleeve 835f, the spring 835e, the ring 835d, the ring 835c, the pin 835b, and the tubular sleeve 835a are displaced in the forward axial direction thereby also displacing the split ring collar 830 and the expansion cone segments 825 in the forward axial direction. As a result, the expansion cone segments 825 are driven up the tapered
15 hexagonal portion 815gb of the expansion cone support body 815g of the tubular support member 815 into contact with the stop member 320. Furthermore, as a result of the forward axial displacement of the tubular sleeve 835f, the radial passages, 815d and 835fh, are fluidically decoupled. As a result fluidic materials within the tubular support member 815 may not pass into the annulus between the tubular support
20 member and the tubular member 120.

As a result of the forward axial displacement of the resilient dog 435e, the outside diameter of the expansion cone segments 825 is now greater than the inside diameter of expandable tubular member 120 thereby permitting the apparatus 800 to be used to radially expand and plastically deform the tubular member, and fluidic
25 materials within the interior 815a of the tubular support member 815 may no longer pass through the radial passages, 815d and 455ed, into the annulus between the apparatus 800 and the tubular member thereby permitting the interior of the apparatus to be pressurized.

The apparatus 800 may then be operated to radially expand and plastically
30 deform the tubular member 120 by applying an upward axial force to the tubular support member 815 and/or by injecting a pressurized fluidic material into the tubular support member.

In particular, as illustrated in Figs. 17 and 17a-17c, the expandable tubular member 120 may then be radially expanded using the apparatus 800 by injecting a
35 fluidic material 275 into the apparatus through the passages 805a, 810a, 815a, and 820a. The injection of the fluidic material 275 may pressurize the interior 120a of the

expandable tubular member 120. In addition, because the packer cup assemblies, 840 and 850, seal off an annular region 120aa below the packer cup assemblies between the expandable tubular member 120 and the tubular support member 815, the injection of the fluidic material 275 may also pressurize the annular region.

5 The continued injection of the fluidic material 275 may then pressurize the interior 120a of the expandable tubular member 120 thereby plastically deforming and radially expanding the expandable tubular member off of the expansion cone segments 825. Because the outer surfaces, 825bb and 825bc, of the expansion cone segments 825 are tapered, the plastic deformation and radial expansion of the expandable
10 tubular member 120 proximate the expansion cone segments is facilitated. Furthermore, in an exemplary embodiment, the continued injection of the fluidic material 275 also pressurizes the annular region 120aa defined between the interior surface of the expandable tubular member 120 and the exterior surface of the tubular support member 815 that is bounded on the upper end by the packer cup assembly
15 840 and on the lower end by the expansion cone segments 825. Furthermore, in an exemplary embodiment, the pressurization of the annular region 120aa also radially expands at least a portion of the surrounding portion of the expandable tubular member 120. In this manner, the plastic deformation and radial expansion of the expandable tubular member 120 is enhanced. Furthermore, during operation of the apparatus 300,
20 the packer cup assemblies 840 and 850 prevent the pressurized fluidic material 275 from passing above and beyond the packer cup assemblies and thereby define the length of the pressurized annular region 120aa. In an exemplary embodiment, the pressurization of the annular region 120aa decreases the operating pressures required for plastic deformation and radial expansion of the expandable tubular member 120 by
25 as much as 50% and also reduces the angle of attack of the tapered external surfaces, 825bb and 825bc, of the expansion cone segments 825.

 The radial expansion of the expandable tubular member 120 may then continue until the upper end 120b of the expandable tubular member is radially expanded and plastically deformed along with the overlapping portion of the wellbore casing 110.
30 Because the expansion cone segments 825 may be adjustably positioned from an outside diameter less than the inside diameter of the expandable tubular member 120 to an outside diameter substantially equal to the inside diameter of the pre-existing casing 110, the resulting wellbore casing, including the casing 110 and the radially expanded tubular member 120, created by the operation of the apparatus 800 may
35 have a single substantially constant inside diameter thereby providing a mono-diameter wellbore casing.

During the radial expansion process, the expansion cone segments 825 may be raised out of the expanded portion of the tubular member 120 by applying an upward axial force to the tubular support member 815. In a preferred embodiment, during the radial expansion process, the expansion cone segments 825 are raised at

5 approximately the same rate as the tubular member 120 is expanded in order to keep the tubular member stationary relative to the new wellbore section 115.

In a preferred embodiment, when the upper end portion of the expandable tubular member 120 and the lower portion of the wellbore casing 110 that overlap with one another are plastically deformed and radially expanded by the expansion cone

10 segments 825, the expansion cone segments are displaced out of the wellbore 100 by both the operating pressure within the interior of the tubular member 120 and a upwardly directed axial force applied to the tubular support member 405.

In a preferred embodiment, the operating pressure and flow rate of the fluidic material 275 is controllably ramped down when the expansion cone segments 825

15 reach the upper end portion of the expandable tubular member 120. In this manner, the sudden release of pressure caused by the complete radial expansion and plastic deformation of the expandable tubular member 120 off of the expansion cone segments 825 can be minimized. In a preferred embodiment, the operating pressure is reduced in a substantially linear fashion from 100% to about 10% during the end of the

20 extrusion process beginning when the expansion cone segments 825 are within about 5 feet from completion of the extrusion process.

Alternatively, or in combination, the wall thickness of the upper end portion of the expandable tubular member 120 is tapered in order to gradually reduce the required operating pressure for plastically deforming and radially expanding the upper

25 end portion of the tubular member. In this manner, shock loading of the apparatus is at least reduced.

Alternatively, or in combination, a shock absorber is provided in the tubular support member 805 in order to absorb the shock caused by the sudden release of pressure. The shock absorber may comprise, for example, any conventional

30 commercially available shock absorber, bumper sub, or jars adapted for use in wellbore operations.

Alternatively, or in combination, an expansion cone catching structure is provided in the upper end portion of the expandable tubular member 120 in order to catch or at least decelerate the expansion cone segments 825.

35 Alternatively, or in combination, during the radial expansion process, an upward axial force is applied to the tubular support member 815 sufficient to plastically deform

and radially expand the tubular member 120 off of the external surfaces, 225bb and 225bc, of the expansion cone segments 825.

Alternatively, or in combination, in order to facilitate the pressurization of the interior 120a of the expandable tubular member by the injection of the fluidic materials 275, the region within the wellbore section 115 below the apparatus 800 may be fluidically sealed off in a convention manner using, for example, a packer.

Once the radial expansion process is completed, the tubular support member 805, the tubular support member 810, the tubular support member 815, the end stop 820, the expansion cone segments 825, the split ring collar 830, the dog assembly 835, the packer cup assembly 840, the spacer 845, and the packer cup assembly 850 are removed from the wellbores 100 and 115.

If the expansion cone segments 825 become lodged within the expandable tubular member 120 during the radial expansion process, then a ball 280 may be placed in the throat 815aa of the passage 815a of the tubular support member 815. The continued injection of the fluidic material 275 following the placement of the ball 280 in the throat 815aa of the passage 815a of the tubular support member will then pressurize the radial passage 815b and an annular portion 835fga of the counterbore 835fg. As a result of the pressurization of the annular portion 835fga of the counterbore 835fg, the tubular sleeve 835f, the pin 835b, the retaining ring 835c, the ring 835d, the spring 835e, and the tubular sleeve 835a of the dog assembly 835, and the split ring collar 830 are driven backward thereby displacing the expansion cone segments 825 backwards in the axial direction away from the end stop 820. In this manner, the outside diameter of the expansion cone segments 825 is thereby reduced and the apparatus 800 may then be removed from the expandable tubular member 120.

Referring now to Figs. 18a, 18b, 18c, and 18d, an embodiment of an adjustable expansion cone assembly 900 will be described. The assembly 900 includes a tubular support member 905 that defines a passage 905a and includes an expansion cone support flange assembly 905b that is coupled to an end stop 910 that defines a passage 910a. The expansion cone support flange assembly 905b includes a first tubular end 905ba, a second tubular end 905bb, and an intermediate hexagonal conical tubular body 905bc that includes a plurality of substantially identical and equally spaced apart expansion cone segment support slots 905bcaa-905bcac on each of the facets of the hexagonal tubular body.

A plurality of first expansion cone segments 915a-915c are provided that include T-shaped retaining members 915aa-915ca that mate with and are movably

received within the T-shaped slots 905bcaa, 905bcac, and 905bcae of the hexagonal conical tubular body 905bc of the expansion cone support assembly 905b, T-shaped retaining members 915ab-915cb, exterior top surfaces 915ac-915cc, exterior top surfaces 915ad-915cd, exterior top surfaces 915ae-915ce, exterior top surfaces 915af-
5 915cf, and exterior top surfaces 915ag-915cg. In an exemplary embodiment, the exterior top surfaces 915ac-915cc and the exterior top surfaces 915ad-915cd are arcuate conical surfaces in which the angle of attack of the exterior top surfaces 915ac-915cc is greater than the angle of attack of the exterior top surfaces 915ad-915cd.

A plurality of second expansion cone segments 920a-920c, that are interleaved
10 with and complementary shaped to the first expansion cone segments 915a-915c, are also provided that include T-shaped retaining members 920aa-920ca that mate with and are movably received within the T-shaped slots 905bcab, 905bcad, and 905bcac of the hexagonal conical tubular body 905bc of the expansion cone support assembly 905b, T-shaped retaining members 920ab-920cb, exterior top surfaces 920ac-920cc,
15 exterior top surfaces 920ad-920cd, exterior top surfaces 920ae-920ce, exterior top surfaces 920af-920cf, and exterior top surfaces 920ag-920cg. In an exemplary embodiment, the exterior top surfaces 920ac-920cc and the exterior top surfaces 920ad-920cd are arcuate conical surfaces in which the angle of attack of the exterior top surfaces 920ac-920cc is greater than the angle of attack of the exterior top
20 surfaces 920ad-920cd.

A split ring collar 925 is provided that defines a passage 925a for receiving the tubular support member 905 that includes an L-shaped retaining member 925b at one end and another end of the split ring collar 925 includes T-shaped slots, 925c, 925d, 925e, 925f, 925g, and 925h, for mating with and receiving the T-shaped retaining
25 members, 915ab, 920ab, 915bb, 920bb, 915cb, and 920cb, of the expansion cone segments, 915a, 920a, 915b, 920b, 915c, and 920c, respectively. A tubular sleeve 930 is provided that defines a passage 930a for receiving the tubular support member 905 and that also includes a slot 930b for receiving and mating with the L-shaped retaining member 925b of the split ring collar 925.

30 During operation of the assembly 900, as illustrated in Figs. 18a, 18b, 18c, and 18d, in an unexpanded position, the expansion cone segments, 915a, 915b, 915c, 915d, 920a, 920b, 920c, and 920d are positioned adjacent to the base of the hexagonal conical tubular body 905bc of the expansion cone support flange 905b away from the end stop 910. In this manner, the outside diameter of the expansion cone
35 segments is less than or equal to the maximum outside diameter of the assembly. Furthermore, in the unexpanded position, the expansion cone segments, 915a, 915b,

and 915c, are positioned further away from the end stop 910 than the expansion cone segments, 920a, 920b, and 920c.

As illustrated in Figs. 19 and 19a, the assembly 900 may then be expanded by displacing the tubular sleeve 930 and the split ring collar 925 in the axial direction
5 towards the expansion cone segment support members 705bb. As a result, the expansion cone segments, 915a, 915b, 915c, 920a, 920b, 920c, are driven up the hexagonal conical tubular body 905bc of the expansion cone support flange 905b until the expansion cone segments impact the end stop 910. In this manner, the outside diameter of the expansion segments, 915a, 915b, 915c, 920a, 920b, and 920c, is
10 greater than the maximum diameter of the remaining components of the assembly 900. Furthermore, the conical outer surfaces, 915ac, 915bc, 915cc, 920ac, 920bc, and 920cc, and the conical outer surfaces, 915ad, 915bd, 915cd, 920ad, 920bd, and 920cd of the expansion cone segments, 915a, 915b, 915c, 920a, 920b, and 920c, respectively, may now be used to radially expand a tubular member. In an exemplary
15 embodiment, the outer conical surfaces, 915ac, 915bc, 915cc, 920ac, 920bc, and 920cc, and the conical outer surfaces, 915ad, 915bd, 915cd, 920ad, 920bd, and 920cd of the expansion cone segments, 915a, 915b, 915c, 920a, 920b, and 920c, respectively, in the expanded position of the assembly 900, provide a substantially continuous outer conical surfaces in the circumferential direction. Furthermore, note
20 that in the expanded position of the assembly 900, the first set of expansion cone segments, 915a, 915b, and 915c, are brought into alignment with the second set of expansion cone segments, 920a, 920b, and 920c.

The assembly 900 may then be returned to the unexpanded position by displacing the tubular sleeve 930 and the split ring collar 925 in the axial direction away
25 from the end stop 910. As a result, the expansion cone segments, 915a, 915b, 915c, 920a, 920b, and 920c, are displaced away from the end top 910, down the conical hexagonal tubular member 905bc and thereby are returned to a position in which the outside diameter of the expansion cone segments is less than or equal to the maximum diameter of the remaining components of the assembly 900.

30 In several alternative embodiments, the assembly 900 is incorporated into the assemblies 200, 300, 400, and 800.

Referring to Fig. 20a, an embodiment of an expansion cone segment assembly 1000 includes interlocking expansion cone segments, 1000a, 1000b, 1000c, 1000d, 1000e, and 1000f.

Referring to Fig. 20b, an embodiment of an expansion cone segment assembly 1100 includes interlocking expansion cone segments, 1100a, 1100b, 1100c, 1100d, 1100e, and 1100f.

5 Referring to Fig. 20c, an embodiment of an expansion cone segment assembly 1200 includes interlocking expansion cone segments, 1200a, 1200b, 1200c, 1200d, 1200e, and 1200f.

Referring to Fig. 20d, an embodiment of an expansion cone segment assembly 1300 includes interlocking expansion cone segments, 1300a, 1300b, 1300c, 1300d, 1300e, and 1300f.

10 Referring to Fig. 20e, an embodiment of an expansion cone segment assembly 1400 includes interlocking expansion cone segments, 1400a, 1400b, 1400c, 1400d, 1400e, and 1400f.

Referring to Fig. 20f, an embodiment of an expansion cone segment assembly 1500 includes interlocking expansion cone segments, 1500a, 1500b, 1500c, 1500d, 1500e, and 1500f.

Referring to Fig. 20g, an embodiment of an expansion cone segment assembly 1600 includes interlocking expansion cone segments, 1600a, 1600b, 1600c, 1600d, 1600e, and 1600f.

20 Referring to Fig. 20h, an embodiment of an expansion cone segment assembly 1700 includes interlocking expansion cone segments, 1700a, 1700b, 1700c, 1700d, 1700e, and 1700f.

Referring to Fig. 20i, an embodiment of an expansion cone segment assembly 1800 includes interlocking expansion cone segments, 1800a, 1800b, 1800c, 1800d, 1800e, and 1800f.

25 Referring to Fig. 20j, an embodiment of an expansion cone segment assembly 1900 includes interlocking expansion cone segments, 1900a, 1900b, 1900c, 1900d, 1900e, and 1900f.

Referring to Fig. 20k, an embodiment of an expansion cone segment assembly 2000 includes interlocking expansion cone segments, 2000a, 2000b, 2000c, 2000d, 2000e, and 2000f.

Referring to Fig. 20l, an embodiment of an expansion cone segment assembly 2100 includes interlocking expansion cone segments, 2100a, 2100b, 2100c, 2100d, 2100e, and 2100f.

35 Referring to Fig. 20m, an embodiment of an expansion cone segment assembly 2200 includes interlocking expansion cone segments, 2200a, 2200b, 2200c, 2200d, 2200e, and 2200f.

The expansion cone segment assemblies 1000, 1100, 1200, 1300, 1400, 1500, 1600, 1700, 1800, 1900, 2000, 2100, and 2200 provide enhanced operational properties such as, for example, efficient radial expansion of expandable tubular members and durability during operation.

5 In several alternative embodiments, the design and operational features of the apparatus 200, 300, 400, 500, 600, 700, 800, 900, 1000, 1100, 1200, 1300, 1400, 1500, 1600, 1700, 1800, 1900, 2000, 2100, and 2200 may be combined, in whole or in part, and/or the design and operational elements of the apparatus 200, 300, 400, 500, 600, 700, 800, 900, 1000, 1100, 1200, 1300, 1400, 1500, 1600, 1700, 1800, 1900,
10 2000, 2100, and 2200 may be interspersed among each other.

In several alternative embodiments, the apparatus 200, 300, 400, 500, 600, 700, 800, 900, and 1000, 1100, 1200, 1300, 1400, 1500, 1600, 1700, 1800, 1900, 2000, 2100, and 2200 may be used to form or repair wellbore casings, pipelines, or structural supports.

15 In several alternative embodiments, the apparatus 200, 300, 400, 500, 600, 700, 800, 900, 1000, 1100, 1200, 1300, 1400, 1500, 1600, 1700, 1800, 1900, 2000, 2100, and 2200 include two or more expansion cone segments that may be movably support and guided on a tapered expansion cone support body that may, for example, be conical, or may be a multi-sided body.

20 In several alternative embodiments, the design and operation of the apparatus 200, 300, 400, 500, 600, 700, 800, 900, 1000, 1100, 1200, 1300, 1400, 1500, 1600, 1700, 1800, 1900, 2000, 2100, and 2200 are provided substantially as disclosed in one or more of the following: (1) U.S. patent application serial no. 09/454,139, attorney docket no. 25791.03.02, filed on 12/3/1999, (2) U.S. patent application serial no.
25 09/510,913, attorney docket no. 25791.7.02, filed on 2/23/2000, (3) U.S. patent application serial no. 09/502,350, attorney docket no. 25791.8.02, filed on 2/10/2000, (4) U.S. patent application serial no. 09/440,338, attorney docket no. 25791.9.02, filed on 11/15/1999, (5) U.S. patent application serial no. 09/523,460, attorney docket no. 25791.11.02, filed on 3/10/2000, (6) U.S. patent application serial no. 09/512,895,
30 attorney docket no. 25791.12.02, filed on 2/24/2000, (7) U.S. patent application serial no. 09/511,941, attorney docket no. 25791.16.02, filed on 2/24/2000, (8) U.S. patent application serial no. 09/588,946, attorney docket no. 25791.17.02, filed on 6/7/2000, (9) U.S. patent application serial no. 09/559,122, attorney docket no. 25791.23.02, filed on 4/26/2000, (10) PCT patent application serial no. PCT/US00/18635, attorney docket
35 no. 25791.25.02, filed on 7/9/2000, (11) U.S. provisional patent application serial no. 60/162,671, attorney docket no. 25791.27, filed on 11/1/1999, (12) U.S. provisional

patent application serial no. 60/154,047, attorney docket no. 25791.29, filed on 9/16/1999, (13) U.S. provisional patent application serial no. 60/159,082, attorney docket no. 25791.34, filed on 10/12/1999, (14) U.S. provisional patent application serial no. 60/159,039, attorney docket no. 25791.36, filed on 10/12/1999, (15) U.S. provisional patent application serial no. 60/159,033, attorney docket no. 25791.37, filed on 10/12/1999, (16) U.S. provisional patent application serial no. 60/212,359, attorney docket no. 25791.38, filed on 6/19/2000, (17) U.S. provisional patent application serial no. 60/165,228, attorney docket no. 25791.39, filed on 11/12/1999, (18) U.S. provisional patent application serial no. 60/221,443, attorney docket no. 25791.45, filed on 7/28/2000, (19) U.S. provisional patent application serial no. 60/221,645, attorney docket no. 25791.46, filed on 7/28/2000, (20) U.S. provisional patent application serial no. 60/233,638, attorney docket no. 25791.47, filed on 9/18/2000, (21) U.S. provisional patent application serial no. 60/237,334, attorney docket no. 25791.48, filed on 10/2/2000, (22) U.S. provisional patent application serial no. 60/270,007, attorney docket no. 25791.50, filed on 2/20/2001; and (23) U.S. provisional patent application serial no. 60/262,434, attorney docket no. 25791.51, filed on 1/17/2001; and (24) U.S. provisional patent application serial no. 60/259,486, attorney docket no. 25791.52, filed on 1/3/2001, the disclosures of which are incorporated herein by reference.

An apparatus for radially expanding a tubular member has been described that includes a tubular support member that includes a first tubular support body defining a longitudinal passage, a first lug coupled to and extending from the first tubular support body in the radial direction, a second lug coupled to and extending from the first tubular support body in the radial direction, and an expansion cone support body coupled to the first tubular support body. The expansion cone support body includes an N-sided tapered tubular support member, wherein each side of the multi-sided tapered tubular support member defines a T-shaped slot. N expansion cone segments are movably coupled to the expansion cone support body, each including an expansion cone segment body including arcuate conical outer surfaces, a first T-shaped retaining member coupled to the expansion cone segment body for movably coupling the expansion cone segment body to a corresponding one of the T-shaped slots of the expansion cone support body, and a second T-shaped retaining member coupled to the expansion cone segment body. A split ring collar assembly is movably coupled to the exterior of the tubular support member that includes a second tubular support body defining N T-shaped slots for movably receiving corresponding ones of the second T-shaped retaining members of the expansion cone segments, and an L-shaped retaining member coupled to the second tubular support body. A first drag block

assembly is movably coupled to the tubular support member that includes a first drag block body defining a slot for receiving and mating with the L-shaped retaining member of the split ring collar, and a first J-shaped slot for receiving the first lug, and one or more first drag blocks coupled to the first drag block body. A second drag block assembly is movably coupled to the tubular support member that includes a second drag block body defining a second J-shaped slot for receiving the second lug, and one or more second drag blocks coupled to the second drag block body. First and second packer cups are coupled to the tubular support member between the first and second drag block assemblies.

10 An apparatus for radially expanding a tubular member has also been described that includes a tubular support member that includes a first tubular support body defining a longitudinal passage, a first flange coupled to the first tubular support body, a second flange coupled to the first tubular support body, a first tapered flange coupled to the first tubular support body, a second tapered flange coupled to the first tubular support body, and an expansion cone support body coupled to the first tubular support body. The expansion cone support body includes an N-sided tapered tubular support member, wherein each side of the multi-sided tapered tubular support member defines a T-shaped slot. N expansion cone segments are movably coupled to the expansion cone support body, each including an expansion cone segment body including arcuate conical outer surfaces, a first T-shaped retaining member coupled to the expansion cone segment body for movably coupling the expansion cone segment body to a corresponding one of the T-shaped slots of the expansion cone support body, and a second T-shaped retaining member coupled to the expansion cone segment body. A split ring collar is movably coupled to the exterior of the tubular support member that includes a second tubular support body that defines N T-shaped slots for movably receiving corresponding ones of the second T-shaped retaining members of the expansion cone segments, and an L-shaped retaining member coupled to the second tubular support body. A first collet assembly is movably coupled to the tubular support member that includes a first tubular sleeve that defines a slot for receiving and mating with the L-shaped retaining member of the split ring collar, a first counterbore for receiving the first flange, and a first radial passage, a first spring received within the first counterbore, a first retaining ring received within the first counterbore, a first load transfer pin coupled to the first retaining ring and extending through the first radial passage, a second tubular sleeve coupled to the first load transfer pin, a first resilient collet coupled to the second tubular sleeve and positioned above the first tapered flange, and a third tubular sleeve coupled to the first resilient collet. A second collet

assembly is movably coupled to the tubular support member that includes a fourth tubular sleeve that defines a second counterbore for receiving the second flange, and a second radial passage, a second spring received within the second counterbore, a second retaining ring received within the second counterbore, a second load transfer
5 pin coupled to the second retaining ring and extending through the second radial passage, a fifth tubular sleeve coupled to the second load transfer pin, a second resilient collet coupled to the fifth tubular sleeve and positioned above the second tapered flange, and a sixth tubular sleeve coupled to the second resilient collet. First and second packer cups coupled to the tubular support member between the first and
10 second collet assemblies.

An apparatus for radially expanding a tubular member has also been described that includes a tubular support member that includes a first tubular support body defining a longitudinal passage, a first radial passage defined in the first tubular support body fluidically coupled to the longitudinal passage, a first flange coupled to the first
15 tubular support body, a second flange coupled to the first tubular support body, a first tapered flange coupled to the first tubular support body, a second tapered flange coupled to the first tubular support body, and an expansion cone support body coupled to the first tubular support body. The expansion cone support body includes an N-sided tapered tubular support member, wherein each side of the multi-sided tapered
20 tubular support member defines a T-shaped slot. N expansion cone segments are movably coupled to the expansion cone support body, each including an expansion cone segment body including arcuate conical outer surfaces, a first T-shaped retaining member coupled to the expansion cone segment body for movably coupling the expansion cone segment body to a corresponding one of the T-shaped slots of the
25 expansion cone support body, and a second T-shaped retaining member coupled to the expansion cone segment body. A split ring collar is movably coupled to the exterior of the tubular support member that includes a second tubular support body that defines N T-shaped slots for movably receiving corresponding ones of the second T-shaped retaining members of the expansion cone segments, and an L-shaped retaining
30 member coupled to the second tubular support body. A first dog assembly is movably coupled to the tubular support member that includes a first tubular sleeve that defines a slot for receiving and mating with the L-shaped retaining member of the split ring collar, a first counterbore for receiving the first flange, and a second radial passage, a first spring received within the first counterbore, a first retaining ring received within the first
35 counterbore, a first load transfer pin coupled to the first retaining ring and extending through the second radial passage, and a second tubular sleeve coupled to the first

load transfer pin that defines a second counterbore for receiving the first tubular sleeve, a first resilient dog coupled to the second tubular sleeve and positioned adjacent to the first tapered flange. A second dog assembly is movably coupled to the tubular support member that includes a third tubular sleeve that defines a second counterbore for
5 receiving the second flange, a third radial passage, and a fourth radial passage fluidically coupled to the first radial passage, a second spring received within the second counterbore, a second retaining ring received within the second counterbore, a second load transfer pin coupled to the second retaining ring and extending through the third radial passage, a fourth tubular sleeve coupled to the second load transfer pin, and a
10 second resilient dog coupled to the fourth tubular sleeve and positioned adjacent to the second tapered flange. First and second packer cups are coupled to the tubular support member between the first and second dog assemblies.

An apparatus for radially expanding a tubular member has also been described that includes a tubular support member that includes a first tubular support body
15 defining a longitudinal passage including a throat passage, a first radial passage defined in the first tubular support body fluidically coupled to the longitudinal passage, a first flange coupled to the first tubular support body, a second flange coupled to the first tubular support body that defines a second radial passage defined in the second flange fluidically coupled to the longitudinal passage, a tapered flange coupled to the first
20 tubular support body, and an expansion cone support body coupled to the first tubular support body. The expansion cone support body includes an N-sided tapered tubular support member, wherein each side of the multi-sided tapered tubular support member defines a T-shaped slot. N expansion cone segments are movably coupled to the expansion cone support body, each including an expansion cone segment body
25 including arcuate conical outer surfaces, a first T-shaped retaining member coupled to the expansion cone segment body for movably coupling the expansion cone segment body to a corresponding one of the T-shaped slots of the expansion cone support body, and a second T-shaped retaining member coupled to the expansion cone segment body. A split ring collar is movably coupled to the exterior of the tubular
30 support member that includes a second tubular support body that defines N T-shaped slots for movably receiving corresponding ones of the second T-shaped retaining members of the expansion cone segments, and an L-shaped retaining member coupled to the second tubular support body. A dog assembly is movably coupled to the tubular support member that includes a first tubular sleeve that defines a slot for
35 receiving and mating with the L-shaped retaining member of the split ring collar, a first counterbore for receiving the first flange, and a third radial passage, a spring received

within the first counterbore, a retaining ring received within the first counterbore, a load transfer pin coupled to the retaining ring and extending through the third radial passage, a second tubular sleeve coupled to the first load transfer pin that defines a first counterbore for receiving the first tubular sleeve, a second counterbore for
5 receiving and mating with the tapered flange, and includes a third flange that defines a third counterbore for receiving the second flange, a fourth counterbore for receiving the second flange, and a fourth radial passage, and a resilient dog coupled to the second tubular sleeve and positioned adjacent to the tapered flange. First and second packer cups are coupled to the tubular support member between the resilient dog and the third
10 flange.

An adjustable expansion cone assembly has also been described that includes a tubular support member that includes a tubular support body and an expansion cone support body coupled to the tubular support body. The expansion cone support body includes an N-sided tapered tubular support member, wherein each side of the multi-
15 sided tapered tubular support member defines a T-shaped slot. N expansion cone segments are movably coupled to the expansion cone support body, each including an expansion cone segment body including arcuate conical outer surfaces, a first T-shaped retaining member coupled to the expansion cone segment body for movably coupling the expansion cone segment body to a corresponding one of the T-shaped
20 slots of the expansion cone support body, and a second T-shaped retaining member coupled to the expansion cone segment body. A split ring collar is movably coupled to the exterior of the tubular support member that includes a second tubular support body that defines N T-shaped slots for movably receiving corresponding ones of the second T-shaped retaining members of the expansion cone segments, and an L-shaped
25 retaining member coupled to the second tubular support body. A tubular actuating sleeve is movably coupled to the tubular support member that includes a third tubular support body that defines a slot for receiving and mating with the L-shaped retaining member of the split ring collar.

An adjustable expansion cone assembly has also been described that includes
30 a tubular support member that includes a first tubular support body, and an expansion cone support body coupled to the tubular support body. The expansion cone support body includes a tapered tubular support member defining N stepped slots. An expansion cone assembly is movably coupled to the tubular support member that includes a second tubular support body movably coupled to the first tubular support
35 body defining an L-shaped slot, and N expansion cone segments extending from the second tubular support member. Each expansion cone segment includes a resilient

collet coupled to the second tubular support member, an expansion cone segment body coupled to the resilient collet including arcuate conical outer surfaces, and a retaining member coupled to the expansion cone segment body for movably coupling the expansion cone segment body to a corresponding one of the stepped slots of the expansion cone support body. A split ring collar is movably coupled to the exterior of the tubular support member that includes a third tubular support body, a first L-shaped retaining member coupled to the third tubular support body for mating with the L-shaped slot of the second tubular support body of the expansion cone assembly, and a second L-shaped retaining member coupled to the third tubular body. A tubular actuating sleeve is movably coupled to the tubular support member that includes a third tubular support body that defines a slot for receiving and mating with the second L-shaped retaining member of the split ring collar.

An adjustable expansion cone assembly has also been described that includes a tubular support member that includes a first tubular support body, and an expansion cone support body coupled to the tubular support body. The expansion cone support body includes a tapered tubular support member defining N slots. An expansion cone assembly is movably coupled to the tubular support member that includes a second tubular support body movably coupled to the first tubular support body defining an L-shaped slot, and N expansion cone segments extending from the second tubular support member. Each expansion cone segment includes a resilient collet coupled to the second tubular support member, an expansion cone segment body coupled to the resilient collet including arcuate conical outer surfaces, and a retaining member coupled to the expansion cone segment body for movably coupling the expansion cone segment body to a corresponding one of the slots of the expansion cone support body. A split ring collar is movably coupled to the exterior of the tubular support member that includes a third tubular support body, a first L-shaped retaining member coupled to the third tubular support body for mating with the L-shaped slot of the second tubular support body, and a second L-shaped retaining member coupled to the third tubular support body. A tubular actuating sleeve is movably coupled to the tubular support member that includes a third tubular support body that defines a slot for receiving and mating with the second L-shaped retaining member of the split ring collar.

An adjustable expansion cone assembly has also been described that includes a tubular support member that includes a first tubular support body, and an expansion cone support body coupled to the tubular support body. The expansion cone support body includes a tapered tubular support member defining N slots. An expansion cone assembly is movably coupled to the tubular support member that includes a second

tubular support body movably coupled to the first tubular support body defining an L-shaped slot, $N/2$ first expansion cone segments extending from the second tubular support member, and $N/2$ second expansion cone segments extending from the second tubular member. Each first expansion cone segment includes a first resilient
5 collet coupled to the second tubular support member, a first expansion cone segment body coupled to the resilient collet including arcuate conical outer surfaces, and a first retaining member coupled to the expansion cone segment body for movably coupling the expansion cone segment body to a corresponding one of the slots of the expansion cone support body. Each second expansion cone segment includes a second resilient
10 collet coupled to the second tubular support member, a second expansion cone segment body coupled to the resilient collet including arcuate conical outer surfaces, and a second retaining member coupled to the expansion cone segment body for movably coupling the expansion cone segment body to a corresponding one of the slots of the expansion cone support body. The second expansion cone segments
15 overlap and are interleaved with the first expansion cone segments. A split ring collar is movably coupled to the exterior of the tubular support member that includes a third tubular support body, a first L-shaped retaining member coupled to the third tubular support body for mating with L-shaped slot of the second tubular support body, and a second L-shaped retaining member coupled to the third tubular support body. A
20 tubular actuating sleeve is movably coupled to the tubular support member that includes a third tubular support body that defines a slot for receiving and mating with the second L-shaped retaining member of the split ring collar.

An adjustable expansion cone assembly has also been described that includes a tubular support member that includes a first tubular support body, and an expansion
25 cone support body coupled to the first tubular support body. The expansion cone support body includes an N -sided tapered tubular support member, wherein each side of the multi-sided tapered tubular support member defines a T-shaped slot. $N/2$ first expansion cone segments are movably coupled to the expansion cone support body, each including a first expansion cone segment body including arcuate conical outer
30 surfaces, a first T-shaped retaining member coupled to the first expansion cone segment body for movably coupling the first expansion cone segment body to a corresponding one of the T-shaped slots of the expansion cone support body, and a second T-shaped retaining member coupled to the first expansion cone segment body. $N/2$ second expansion cone segments are also movably coupled to the expansion cone
35 support body, each including a second expansion cone segment body including arcuate conical outer surfaces, a third T-shaped retaining member coupled to the

second expansion cone segment body for movably coupling the second expansion cone segment body to a corresponding one of the T-shaped slots of the expansion cone support body, and a fourth T-shaped retaining member coupled to the expansion cone segment body. The first and second expansion cone segments are interleaved.

5 The first expansion cone segment bodies are complementary shaped with respect to the second expansion cone segment bodies. A split ring collar assembly is movably coupled to the exterior of the tubular support member that includes a second tubular support body that defines N T-shaped slots for movably receiving corresponding ones of the second and fourth T-shaped retaining members of the interleaved first and
10 second expansion cone segments, and an L-shaped retaining member coupled to the second tubular support body. A tubular actuating sleeve movably coupled to the tubular support member that includes a third tubular support body that defines a slot for receiving and mating with the L-shaped retaining member of the split ring collar.

An apparatus for radially expanding a tubular member has also been described
15 that includes a tubular support member that includes a first tubular support body defining a longitudinal passage, a first lug coupled to and extending from the first tubular support body in the radial direction, and a second lug coupled to and extending from the first tubular support body in the radial direction. An adjustable expansion cone assembly is movably coupled to the tubular support member. A first drag block
20 assembly is movably coupled to the tubular support member that includes a first drag block body coupled to the adjustable expansion cone assembly that defines: a first J-shaped slot for receiving the first lug, and one or more first drag blocks coupled to the first drag block body. A second drag block assembly is movably coupled to the tubular support member that includes a second drag block body that defines: a second J-
25 shaped slot for receiving the second lug, and one or more second drag blocks coupled to the second drag block body. First and second packer cups are coupled to the tubular support member between the first and second drag block assemblies.

An apparatus for radially expanding a tubular member has also been described that includes a tubular support member that includes a first tubular support body
30 defining a longitudinal passage, a first flange coupled to the first tubular support body, a second flange coupled to the first tubular support body, a first tapered flange coupled to the first tubular support body, and a second tapered flange coupled to the first tubular support body. An adjustable expansion cone assembly is movably coupled to the tubular support member. A first collet assembly is movably coupled to the tubular
35 support member that includes a first tubular sleeve coupled to the adjustable expansion cone assembly and defines a first counterbore for receiving the first flange, and a first

radial passage, a first spring received within the first counterbore, a first retaining ring received within the first counterbore, a first load transfer pin coupled to the first retaining ring and extending through the first radial passage, a second tubular sleeve coupled to the first load transfer pin, a first resilient collet coupled to the second tubular sleeve and positioned above the first tapered flange, and a third tubular sleeve coupled to the first resilient collet. A second collet assembly is movably coupled to the tubular support member that includes a fourth tubular sleeve that defines: a second counterbore for receiving the second flange, and a second radial passage, a second spring received within the second counterbore, a second retaining ring received within the second counterbore, a second load transfer pin coupled to the second retaining ring and extending through the second radial passage, a fifth tubular sleeve coupled to the second load transfer pin, a second resilient collet coupled to the fifth tubular sleeve and positioned above the second tapered flange, and a sixth tubular sleeve coupled to the second resilient collet. First and second packer cups are coupled to the tubular support member between the first and second collet assemblies.

An apparatus for radially expanding a tubular member has also been described that includes a tubular support member that includes a first tubular support body defining a longitudinal passage, a first radial passage defined in the first tubular support body fluidically coupled to the longitudinal passage, a first flange coupled to the first tubular support body, a second flange coupled to the first tubular support body, a first tapered flange coupled to the first tubular support body, and a second tapered flange coupled to the first tubular support body. An adjustable expansion cone assembly is movably coupled to the tubular support member. A first dog assembly is movably coupled to the tubular support member that includes a first tubular sleeve coupled to the adjustable expansion cone assembly that defines: a first counterbore for receiving the first flange, and a second radial passage, a first spring received within the first counterbore, a first retaining ring received within the first counterbore, a first load transfer pin coupled to the first retaining ring and extending through the second radial passage, a second tubular sleeve coupled to the first load transfer pin that defines: a second counterbore for receiving the first tubular sleeve, a first resilient dog coupled to the second tubular sleeve and positioned adjacent to the first tapered flange. A second dog assembly is movably coupled to the tubular support member that includes a third tubular sleeve that defines a second counterbore for receiving the second flange, a third radial passage, and a fourth radial passage fluidically coupled to the first radial passage, a second spring received within the second counterbore, a second retaining ring received within the second counterbore, a second load transfer pin coupled to the

second retaining ring and extending through the third radial passage, a fourth tubular sleeve coupled to the second load transfer pin, a second resilient dog coupled to the fourth tubular sleeve and positioned adjacent to the second tapered flange. First and second packer cups are coupled to the tubular support member between the first and second dog assemblies.

An apparatus for radially expanding a tubular member has also been described that includes a tubular support member that includes a first tubular support body defining a longitudinal passage including a throat passage, a first radial passage defined in the first tubular support body fluidically coupled to the longitudinal passage, a first flange coupled to the first tubular support body, and a second flange coupled to the first tubular support body that defines: a second radial passage defined in the second flange fluidically coupled to the longitudinal passage. An adjustable expansion cone assembly is movably coupled to the tubular support member. A dog assembly is movably coupled to the tubular support member that includes a first tubular sleeve coupled to the adjustable expansion cone assembly that defines a first counterbore for receiving the first flange, and a third radial passage, a spring received within the first counterbore, a retaining ring received within the first counterbore, a load transfer pin coupled to the retaining ring and extending through the third radial passage, a second tubular sleeve coupled to the first load transfer pin that defines: a first counterbore for receiving the first tubular sleeve, a second counterbore for receiving and mating with the tapered flange, and includes a third flange that defines a third counterbore for receiving the second flange, a fourth counterbore for receiving the second flange, and a fourth radial passage, and a resilient dog coupled to the second tubular sleeve and positioned adjacent to the tapered flange. First and second packer cups are coupled to the tubular support member between the resilient dog and the third flange.

An apparatus for radially expanding a tubular member has also been described that includes a tubular support member, an adjustable expansion cone assembly movably coupled to the tubular support member, and means for adjusting the adjustable expansion cone assembly.

An adjustable expansion cone assembly has also been described that includes a tubular support member. An adjustable expansion cone is movably coupled to the tubular support member that includes a plurality of expansion cone segments, and means for guiding the expansion cone segments on the tubular support member. The assembly further includes means for adjusting the adjustable expansion cone.

A method of operating an adjustable expansion cone assembly including a plurality of expansion cone segments has also been described that includes guiding the

expansion cone segments on a tapered body, and controllably displacing the expansion cone segments along the tapered body.

5 A method of operating an adjustable expansion cone assembly including a plurality of expansion cone segments has also been described that includes guiding the expansion cone segments on a multi-sided tapered body, interlocking the expansion cone segments, and controllably displacing the expansion cone segments along the tapered body.

10 A method of operating an adjustable expansion cone assembly including a plurality of expansion cone segments has also been described that includes resiliently guiding the expansion cone segments on a multi-sided tapered body, guiding each of the expansion cone segments on opposite sides in the circumferential direction, interlocking the expansion cone segments, and controllably displacing the expansion cone segments along the tapered body.

15 A method of operating an adjustable expansion cone assembly including a plurality of expansion cone segments has also been described that includes dividing the expansion cone segments into first and second groups of expansion cone segments, interleaving the first and second groups of expansion cone segments, overlapping the first and second groups of expansion cone segments, resiliently guiding the expansion cone segments on a multi-sided tapered body, guiding each of the expansion cone segments on opposite sides in the circumferential direction, and controllably displacing the expansion cone segments along the tapered body.

20 A method of operating an adjustable expansion cone assembly including a plurality of expansion cone segments has also been described that includes dividing the expansion cone segments into first and second groups of expansion cone segments, interleaving the first and second groups of expansion cone segments, guiding the expansion cone segments on a multi-sided tapered body, and controllably displacing the expansion cone segments along the tapered body while also relatively displacing the first and second groups of expansion cone segments in opposite directions.

30 A method of plastically deforming and radially expanding an expandable tubular member using an apparatus including a tubular support member, an adjustable expansion cone assembly movably coupled to the tubular support member, and an actuator movably coupled to the tubular support member for adjusting the adjustable expansion cone assembly, has also been described that includes coupling a first end of the expandable tubular member to a tubular structure, locking the actuator to the tubular support member of the apparatus, inserting the apparatus into the first end of

35

the expandable tubular member, moving the actuator and the adjustable expansion cone assembly of the apparatus out of the second end of the expandable tubular member, reinserting the actuator of the apparatus into the second end of the expandable tubular member, unlocking the actuator from the tubular support member of the apparatus, rotating the actuator relative to the tubular support member of the apparatus, and increasing the outside diameter of the adjustable expansion cone assembly by moving the tubular support member relative to the actuator, the adjustable expansion cone assembly and the expandable tubular member, and plastically deforming and radially expanding the expandable tubular member by moving the adjustable expansion cone assembly through the expandable tubular member.

A method of plastically deforming and radially expanding an expandable tubular member using an apparatus including a tubular support member, an adjustable expansion cone assembly movably coupled to the tubular support member, and an actuator movably coupled to the tubular support member for adjusting the adjustable expansion cone assembly, has also been described that includes coupling a first end of the expandable tubular member to a tubular structure, inserting the apparatus into the first end of the expandable tubular member in a first direction, displacing the actuator of the apparatus in a second direction opposite to the first direction, applying a resilient biasing force to the adjustable expansion cone assembly in the second direction, moving the actuator and the adjustable expansion cone assembly of the apparatus out of the second end of the expandable tubular member, reinserting the actuator of the apparatus into the second end of the expandable tubular member in the second direction, increasing the outside diameter of the adjustable expansion cone assembly by displacing the actuator and the adjustable expansion cone assembly relative to the expandable tubular member in the first direction, and plastically deforming and radially expanding the expandable tubular member by moving the adjustable expansion cone assembly through the expandable tubular member in the second direction.

An adjustable expansion cone assembly has also been described that includes a plurality of expansion cone segments, means for guiding the expansion cone segments on a tapered body, and means for controllably displacing the expansion cone segments along the tapered body.

An adjustable expansion cone assembly has also been described that includes a plurality of expansion cone segments, means for guiding the expansion cone segments on a multi-sided tapered body, means for interlocking the expansion cone segments, and means for controllably displacing the expansion cone segments along the tapered body.

An adjustable expansion cone assembly has also been described that includes a plurality of expansion cone segments, means for resiliently guiding the expansion cone segments on a multi-sided tapered body, means for guiding each of the expansion cone segments on opposite sides in the circumferential direction, means for
5 interlocking the expansion cone segments, and means for controllably displacing the expansion cone segments along the tapered body.

An adjustable expansion cone assembly has also been described that includes a plurality of expansion cone segments, means for dividing the expansion cone segments into first and second groups of expansion cone segments, means for
10 interleaving the first and second groups of expansion cone segments, means for overlapping the first and second groups of expansion cone segments, means for resiliently guiding the expansion cone segments on a multi-sided tapered body, means for guiding each of the expansion cone segments on opposite sides in the circumferential direction, and means for controllably displacing the expansion cone
15 segments along the tapered body.

An adjustable expansion cone assembly has also been described that includes a plurality of expansion cone segments, means for dividing the expansion cone segments into first and second groups of expansion cone segments, means for interleaving the first and second groups of expansion cone segments, means for
20 guiding the expansion cone segments on a multi-sided tapered body, and means for controllably displacing the expansion cone segments along the tapered body while also relatively displacing the first and second groups of expansion cone segments in opposite directions.

An apparatus for plastically deforming and radially expanding an expandable
25 tubular member has also been described that includes a tubular support member, an adjustable expansion cone assembly movably coupled to the tubular support member, means for actuating the adjustable expansion cone assembly, means for locking the actuator to the tubular support member of the apparatus, means for unlocking the actuator from the tubular support member of the apparatus, and means for increasing
30 the outside diameter of the adjustable expansion cone assembly by moving the tubular support member relative to the actuator, the adjustable expansion cone assembly, and the expandable tubular member.

An apparatus for plastically deforming and radially expanding an expandable tubular member has also been described that includes a tubular support member, an
35 adjustable expansion cone assembly movably coupled to the tubular support member, means for actuating the adjustable expansion cone assembly, means for displacing the

actuator of the apparatus in a first direction, means for applying a resilient biasing force to the adjustable expansion cone assembly when the actuator is displaced in the first direction, and means for increasing the outside diameter of the adjustable expansion cone assembly by displacing the actuator and the adjustable expansion cone assembly relative to the expandable tubular member in a second direction opposite to the first direction.

Although illustrative embodiments of the invention have been shown and described, a wide range of modification, changes and substitution is contemplated in the foregoing disclosure. In some instances, some features of the present invention may be employed without a corresponding use of the other features. Accordingly, it is appropriate that the appended claims be construed broadly and in a manner consistent with the scope of the invention.

Claims

1. A method of plastically deforming and radially expanding an expandable tubular member using an apparatus comprising a tubular support member, an adjustable expansion cone assembly movably coupled to the tubular support member, and an actuator movably coupled to the tubular support member for adjusting the adjustable expansion cone assembly, comprising:
- 5 coupling a first end of the expandable tubular member to a tubular structure;
inserting the apparatus into the first end of the expandable tubular member in a
10 first direction;
displacing the actuator of the apparatus in a second direction opposite to the first direction;
applying a resilient biasing force to the adjustable expansion cone assembly in the second direction;
- 15 moving the actuator and the adjustable expansion cone assembly of the apparatus out of a second end of the expandable tubular member;
reinserting the actuator of the apparatus into the second end of the expandable tubular member in the second direction;
increasing the outside diameter of the adjustable expansion cone assembly by
20 displacing the actuator and the adjustable expansion cone assembly relative to the expandable tubular member in the first direction; and
plastically deforming and radially expanding the expandable tubular member by moving the adjustable expansion cone assembly through the expandable tubular member in the second direction.
- 25
2. The method of claim 1, wherein displacing the actuator of the apparatus in the second direction comprises:
impacting the actuator with the first end of the expandable tubular member.
- 30
3. The method of claim 1, wherein displacing the actuator and the adjustable expansion cone assembly relative to the expandable tubular member in the first direction comprises:
impacting the actuator with the second end of the expandable tubular member.
- 35
4. The method of claim 1, wherein moving the adjustable expansion cone assembly through the expandable tubular member comprises:

pulling the adjustable expansion cone through the expandable tubular member.

5. The method of claim 1, further comprising:
 - fluidically sealing the interface between the tubular support member of the
 - 5 apparatus and the expandable tubular member;
 - wherein moving the adjustable expansion cone assembly through the expandable tubular member comprises:
 - injecting a pressurized fluid into the tubular support member.

1. An apparatus for radially expanding a tubular member, comprising:
 - a tubular support member comprising:
 - 5 a first tubular support body defining a longitudinal passage;
 - a first lug coupled to and extending from the first tubular support body in the radial direction;
 - a second lug coupled to and extending from the first tubular support body in the radial direction; and
 - 10 an expansion cone support body coupled to the first tubular support body comprising:
 - an N-sided tapered tubular support member;
 - wherein each side of the multi-sided tapered tubular support member defines a T-shaped slot;
 - 15 N expansion cone segments movably coupled to the expansion cone support body, each comprising:
 - an expansion cone segment body including arcuate conical outer surfaces;
 - 20 a first T-shaped retaining member coupled to the expansion cone segment body for movably coupling the expansion cone segment body to a corresponding one of the T-shaped slots of the expansion cone support body; and
 - a second T-shaped retaining member coupled to the expansion cone segment body;
 - 25 a split ring collar assembly movably coupled to the exterior of the tubular support member comprising:
 - a second tubular support body defining:
 - 30 N T-shaped slots for movably receiving corresponding ones of the second T-shaped retaining members of the expansion cone segments; and
 - an L-shaped retaining member coupled to the second tubular support body;
 - a first drag block assembly movably coupled to the tubular support member that comprises:
 - 35 a first drag block body defining:

- a slot for receiving and mating with the L-shaped retaining member of the split ring collar; and
 a first J-shaped slot for receiving the first lug; and
 one or more first drag blocks coupled to the first drag block body;
- 5 a second drag block assembly movably coupled to the tubular support member that comprises:
 a second drag block body defining:
 a second J-shaped slot for receiving the second lug; and
 one or more second drag blocks coupled to the second drag block body;
- 10 and
 first and second packer cups coupled to the tubular support member between the first and second drag block assemblies.
2. An apparatus for radially expanding a tubular member, comprising:
- 15 a tubular support member comprising:
 a first tubular support body defining a longitudinal passage;
 a first flange coupled to the first tubular support body;
 a second flange coupled to the first tubular support body;
 a first tapered flange coupled to the first tubular support body;
- 20 a second tapered flange coupled to the first tubular support body; and
 an expansion cone support body coupled to the first tubular support body comprising:
 an N-sided tapered tubular support member;
 wherein each side of the multi-sided tapered tubular support
- 25 member defines a T-shaped slot;
 N expansion cone segments movably coupled to the expansion cone support body, each comprising:
 an expansion cone segment body including arcuate conical outer surfaces;
- 30 a first T-shaped retaining member coupled to the expansion cone segment body for movably coupling the expansion cone segment body to a corresponding one of the T-shaped slots of the expansion cone support body; and
 a second T-shaped retaining member coupled to the expansion cone
- 35 segment body;

- a split ring collar movably coupled to the exterior of the tubular support member comprising:
- a second tubular support body that defines:
 - N T-shaped slots for movably receiving corresponding ones of
 - 5 the second T-shaped retaining members of the expansion cone segments; and
 - an L-shaped retaining member coupled to the second tubular support body;
 - a first collet assembly movably coupled to the tubular support member that
 - 10 comprises:
 - a first tubular sleeve defining:
 - a slot for receiving and mating with the L-shaped retaining
 - member of the split ring collar;
 - a first counterbore for receiving the first flange; and
 - 15 a first radial passage;
 - a first spring received within the first counterbore;
 - a first retaining ring received within the first counterbore;
 - a first load transfer pin coupled to the first retaining ring and extending
 - through the first radial passage;
 - 20 a second tubular sleeve coupled to the first load transfer pin;
 - a first resilient collet coupled to the second tubular sleeve and positioned above the first tapered flange; and
 - a third tubular sleeve coupled to the first resilient collet;
 - a second collet assembly movably coupled to the tubular support member that
 - 25 comprises:
 - a fourth tubular sleeve defining:
 - a second counterbore for receiving the second flange; and
 - a second radial passage;
 - a second spring received within the second counterbore;
 - 30 a second retaining ring received within the second counterbore;
 - a second load transfer pin coupled to the second retaining ring and extending through the second radial passage;
 - a fifth tubular sleeve coupled to the second load transfer pin;
 - a second resilient collet coupled to the fifth tubular sleeve and
 - 35 positioned above the second tapered flange; and
 - a sixth tubular sleeve coupled to the second resilient collet; and

first and second packer cups coupled to the tubular support member between the first and second collet assemblies.

3. An apparatus for radially expanding a tubular member, comprising:
- 5 a tubular support member comprising:
- a first tubular support body defining a longitudinal passage;
 - a first radial passage defined in the first tubular support body fluidically coupled to the longitudinal passage;
 - a first flange coupled to the first tubular support body;
 - 10 a second flange coupled to the first tubular support body;
 - a first tapered flange coupled to the first tubular support body;
 - a second tapered flange coupled to the first tubular support body; and
 - an expansion cone support body coupled to the first tubular support body comprising:
 - 15 an N-sided tapered tubular support member;
 - wherein each side of the multi-sided tapered tubular support member defines a T-shaped slot;
 - N expansion cone segments movably coupled to the expansion cone support body, each comprising:
 - 20 an expansion cone segment body including arcuate conical outer surfaces;
 - a first T-shaped retaining member coupled to the expansion cone segment body for movably coupling the expansion cone segment body to a corresponding one of the T-shaped slots of the expansion cone support body; and
 - 25 a second T-shaped retaining member coupled to the expansion cone segment body;
 - a split ring collar movably coupled to the exterior of the tubular support member comprising:
 - 30 a second tubular support body defining:
 - N T-shaped slots for movably receiving corresponding ones of the second T-shaped retaining members of the expansion cone segments; and
 - 35 an L-shaped retaining member coupled to the second tubular support body;

a first dog assembly movably coupled to the tubular support member that comprises:

a first tubular sleeve defining:

5

a slot for receiving and mating with the L-shaped retaining member of the split ring collar;

a first counterbore for receiving the first flange; and

a second radial passage;

a first spring received within the first counterbore;

a first retaining ring received within the first counterbore;

10

a first load transfer pin coupled to the first retaining ring and extending through the second radial passage;

a second tubular sleeve coupled to the first load transfer pin defining:

a second counterbore for receiving the first tubular sleeve;

15

a first resilient dog coupled to the second tubular sleeve and positioned adjacent to the first tapered flange;

a second dog assembly movably coupled to the tubular support member that comprises:

a third tubular sleeve defining:

20

a second counterbore for receiving the second flange;

a third radial passage; and

a fourth radial passage fluidically coupled to the first radial passage;

a second spring received within the second counterbore;

a second retaining ring received within the second counterbore;

25

a second load transfer pin coupled to the second retaining ring and extending through the third radial passage;

a fourth tubular sleeve coupled to the second load transfer pin;

a second resilient dog coupled to the fourth tubular sleeve and positioned adjacent to the second tapered flange; and

30

first and second packer cups coupled to the tubular support member between the first and second dog assemblies.

4. An apparatus for radially expanding a tubular member, comprising:

a tubular support member comprising:

35

a first tubular support body defining a longitudinal passage including a throat passage;

a first radial passage defined in the first tubular support body fluidically coupled to the longitudinal passage;

a first flange coupled to the first tubular support body;

a second flange coupled to the first tubular support body defining:

5 a second radial passage defined in the second flange fluidically coupled to the longitudinal passage;

a tapered flange coupled to the first tubular support body; and

an expansion cone support body coupled to the first tubular support body comprising:

10 an N-sided tapered tubular support member;

 wherein each side of the multi-sided tapered tubular support member defines a T-shaped slot;

N expansion cone segments movably coupled to the expansion cone support body, each comprising:

15 an expansion cone segment body including arcuate conical outer surfaces;

 a first T-shaped retaining member coupled to the expansion cone segment body for movably coupling the expansion cone segment body to a corresponding one of the T-shaped slots of the

20 expansion cone support body; and

 a second T-shaped retaining member coupled to the expansion cone segment body;

a split ring collar movably coupled to the exterior of the tubular support member comprising:

25 a second tubular support body defining:

 N T-shaped slots for movably receiving corresponding ones of the second T-shaped retaining members of the expansion cone segments; and

 an L-shaped retaining member coupled to the second tubular support

30 body;

a dog assembly movably coupled to the tubular support member that comprises:

 a first tubular sleeve defining:

 a slot for receiving and mating with the L-shaped retaining

35 member of the split ring collar;

 a first counterbore for receiving the first flange; and

- a third radial passage;
 a spring received within the first counterbore;
 a retaining ring received within the first counterbore;
 a load transfer pin coupled to the retaining ring and extending through
 5 the third radial passage;
 a second tubular sleeve coupled to the first load transfer pin that
 defines:
 - a first counterbore for receiving the first tubular sleeve;
 - a second counterbore for receiving and mating with the
 10 tapered flange; and
 comprises:
 - a third flange defining:
 - a third counterbore for receiving the second
 15 flange;
 - a fourth counterbore for receiving the second
 flange; and
 - a fourth radial passage; and
 - a resilient dog coupled to the second tubular sleeve and positioned
 adjacent to the tapered flange; and
 - 20 first and second packer cups coupled to the tubular support member between
 the resilient dog and the third flange.
5. An adjustable expansion cone assembly, comprising:
- a tubular support member comprising:
- 25 a tubular support body; and
- an expansion cone support body coupled to the tubular support body
 comprising:
- an N-sided tapered tubular support member;
 wherein each side of the multi-sided tapered tubular support
 30 member defines a T-shaped slot;
- N expansion cone segments movably coupled to the expansion cone support
 body, each comprising:
- an expansion cone segment body including arcuate conical outer
 surfaces;
- 35 a first T-shaped retaining member coupled to the expansion cone
 segment body for movably coupling the expansion cone segment

- body to a corresponding one of the T-shaped slots of the expansion cone support body; and
a second T-shaped retaining member coupled to the expansion cone segment body;
- 5 a split ring collar movably coupled to the exterior of the tubular support member comprising:
a second tubular support body defining:
N T-shaped slots for movably receiving corresponding ones of
the second T-shaped retaining members of the
10 expansion cone segments; and
an L-shaped retaining member coupled to the second tubular support body; and
a tubular actuating sleeve movably coupled to the tubular support member that comprises:
15 a third tubular support body defining:
a slot for receiving and mating with the L-shaped retaining member of the split ring collar.
6. An adjustable expansion cone assembly, comprising:
20 a tubular support member comprising:
a first tubular support body; and
an expansion cone support body coupled to the tubular support body comprising:
a tapered tubular support member defining N stepped slots;
- 25 an expansion cone assembly movably coupled to the tubular support member comprising:
a second tubular support body movably coupled to the first tubular support body defining an L-shaped slot; and
N expansion cone segments extending from the second tubular support
30 member, each expansion cone segment comprising:
a resilient collet coupled to the second tubular support member;
an expansion cone segment body coupled to the resilient
collet including arcuate conical outer surfaces;
35 and

- a retaining member coupled to the expansion cone
 segment body for movably coupling the expansion
 cone segment body to a corresponding one of the
 stepped slots of the expansion cone support
 5 body;
- a split ring collar movably coupled to the exterior of the tubular support member
 comprising:
 - a third tubular support body;
 - a first L-shaped retaining member coupled to the third tubular support
 - 10 body for mating with the L-shaped slot of the second tubular
 support body of the expansion cone assembly; and
 - a second L-shaped retaining member coupled to the third tubular body;
 - and
 - a tubular actuating sleeve movably coupled to the tubular support member that
 - 15 comprises:
 - a third tubular support body defining:
 - a slot for receiving and mating with the second L-shaped
 - retaining member of the split ring collar.
- 20 7. An adjustable expansion cone assembly, comprising:
 - a tubular support member comprising:
 - a first tubular support body; and
 - an expansion cone support body coupled to the tubular support body
 - comprising:
 - 25 a tapered tubular support member defining N slots;
 - an expansion cone assembly movably coupled to the tubular support member
 - comprising:
 - a second tubular support body movably coupled to the first tubular
 - support body defining an L-shaped slot; and
 - 30 N expansion cone segments extending from the second tubular support
 member, each expansion cone segment comprising:
 - a resilient collet coupled to the second tubular support
 - member;
 - an expansion cone segment body coupled to the resilient
 - 35 collet including arcuate conical outer surfaces;
 - and

- a retaining member coupled to the expansion cone segment body for movably coupling the expansion cone segment body to a corresponding one of the slots of the expansion cone support body;
- 5 a split ring collar movably coupled to the exterior of the tubular support member comprising:
- a third tubular support body;
- a first L-shaped retaining member coupled to the third tubular support body for mating with the L-shaped slot of the second tubular support body; and
- 10 a second L-shaped retaining member coupled to the third tubular support body; and
- a tubular actuating sleeve movably coupled to the tubular support member that comprises:
- 15 a third tubular support body defining:
- a slot for receiving and mating with the second L-shaped retaining member of the split ring collar.
8. An adjustable expansion cone assembly, comprising:
- 20 a tubular support member comprising:
- a first tubular support body; and
- an expansion cone support body coupled to the tubular support body comprising:
- a tapered tubular support member defining N slots;
- 25 an expansion cone assembly movably coupled to the tubular support member comprising:
- a second tubular support body movably coupled to the first tubular support body defining an L-shaped slot; and
- $N/2$ first expansion cone segments extending from the second tubular support member, each first expansion cone segment comprising:
- 30 a first resilient collet coupled to the second tubular support member;
- a first expansion cone segment body coupled to the resilient collet including arcuate conical outer surfaces; and
- 35

- a first retaining member coupled to the expansion cone segment body for movably coupling the expansion cone segment body to a corresponding one of the slots of the expansion cone support body;
- 5 N/2 second expansion cone segments extending from the second tubular support member, each second expansion cone segment comprising:
- a second resilient collet coupled to the second tubular support member;
- 10 a second expansion cone segment body coupled to the resilient collet including arcuate conical outer surfaces; and
- a second retaining member coupled to the expansion cone segment body for movably coupling the expansion cone segment body to a corresponding one of the slots of the expansion cone support body;
- 15 wherein the second expansion cone segments overlap and are interleaved with the first expansion cone segments;
- 20 a split ring collar movably coupled to the exterior of the tubular support member comprising:
- a third tubular support body;
- a first L-shaped retaining member coupled to the third tubular support body for mating with L-shaped slot of the second tubular support body; and
- 25 a second L-shaped retaining member coupled to the third tubular support body; and
- a tubular actuating sleeve movably coupled to the tubular support member that comprises:
- 30 a third tubular support body defining:
- a slot for receiving and mating with the second L-shaped retaining member of the split ring collar.
9. An adjustable expansion cone assembly, comprising:
- 35 a tubular support member comprising:
- a first tubular support body; and

an expansion cone support body coupled to the first tubular support
body comprising:
an N-sided tapered tubular support member;
wherein each side of the multi-sided tapered tubular support
5 member defines a T-shaped slot;
N/2 first expansion cone segments movably coupled to the expansion cone
support body, each comprising:
a first expansion cone segment body including arcuate conical outer
surfaces;
10 a first T-shaped retaining member coupled to the first expansion cone
segment body for movably coupling the first expansion cone
segment body to a corresponding one of the T-shaped slots of
the expansion cone support body; and
a second T-shaped retaining member coupled to the first expansion
15 cone segment body;
N/2 second expansion cone segments movably coupled to the expansion cone
support body, each comprising:
a second expansion cone segment body including arcuate conical outer
surfaces;
20 a third T-shaped retaining member coupled to the second expansion
cone segment body for movably coupling the second expansion
cone segment body to a corresponding one of the T-shaped
slots of the expansion cone support body; and
a fourth T-shaped retaining member coupled to the expansion cone
25 segment body;
wherein the first and second expansion cone segments are interleaved;
wherein the first expansion cone segment bodies are complementary shaped
with respect to the second expansion cone segment bodies;
a split ring collar assembly movably coupled to the exterior of the tubular
30 support member comprising:
a second tubular support body defining:
N T-shaped slots for movably receiving corresponding ones of
the second and fourth T-shaped retaining members of the
interleaved first and second expansion cone segments;
35 and

- an L-shaped retaining member coupled to the second tubular support body; and
a tubular actuating sleeve movably coupled to the tubular support member that comprises:
- 5 a third tubular support body defining:
a slot for receiving and mating with the L-shaped retaining member of the split ring collar.
10. An apparatus for radially expanding a tubular member, comprising:
- 10 a tubular support member comprising:
a first tubular support body defining a longitudinal passage;
a first lug coupled to and extending from the first tubular support body in the radial direction; and
a second lug coupled to and extending from the first tubular support
- 15 body in the radial direction;
an adjustable expansion cone assembly movably coupled to the tubular support member;
a first drag block assembly movably coupled to the tubular support member that comprises:
- 20 a first drag block body coupled to the adjustable expansion cone assembly defining:
a first J-shaped slot for receiving the first lug; and
one or more first drag blocks coupled to the first drag block body;
a second drag block assembly movably coupled to the tubular support member
- 25 that comprises:
a second drag block body defining:
a second J-shaped slot for receiving the second lug; and
one or more second drag blocks coupled to the second drag block body;
and
- 30 first and second packer cups coupled to the tubular support member between the first and second drag block assemblies.
11. The apparatus of claim 10, wherein the tubular support member further comprises:
- 35 an expansion cone support body coupled to the first tubular support body comprising:

an N-sided tapered tubular support member;
 wherein each side of the multi-sided tapered tubular support
 member defines a T-shaped slot;
 wherein the adjustable expansion cone assembly comprises:
 5 N expansion cone segments movably coupled to the expansion cone
 support body, each comprising:
 an expansion cone segment body including arcuate conical outer
 surfaces;
 a first T-shaped retaining member coupled to the expansion
 10 cone segment body for movably coupling the expansion
 cone segment body to a corresponding one of the T-
 shaped slots of the expansion cone support body; and
 a second T-shaped retaining member coupled to the expansion
 cone segment body; and
 15 a split ring collar movably coupled to the exterior of the tubular support
 member comprising:
 a second tubular support body defining:
 N T-shaped slots for movably receiving corresponding
 20 ones of the second T-shaped retaining members
 of the expansion cone segments; and
 an L-shaped retaining member coupled to the second tubular
 support body; and
 wherein the first drag block body further defines:
 a slot for receiving and mating with the L-shaped retaining member of
 25 the split ring collar.

12. The apparatus of claim 10, wherein the tubular support member further
 comprises:
 an expansion cone support body coupled to the tubular support body
 30 comprising:
 a tapered tubular support member defining N stepped slots;
 wherein the adjustable expansion cone assembly comprises:
 an expansion cone assembly movably coupled to the tubular support
 member comprising:
 35 a second tubular support body movably coupled to the first
 tubular support body defining an L-shaped slot; and

N expansion cone segments extending from the second tubular support member, each expansion cone segment comprising:

5

a resilient collet coupled to the second tubular support member;

an expansion cone segment body coupled to the resilient collet including arcuate conical outer surfaces; and

10

a retaining member coupled to the expansion cone segment body for movably coupling the expansion cone segment body to a corresponding one of the stepped slots of the expansion cone support body; and

15

a split ring collar movably coupled to the exterior of the tubular support member comprising:

a third tubular support body:

a first L-shaped retaining member coupled to the third tubular support body for mating with the L-shaped slot of the second tubular support body; and

20

a second L-shaped retaining member coupled to the third tubular support member;

wherein the first drag block body further defines:

a slot for receiving and mating with the second L-shaped retaining member of the split ring collar.

25

13. The apparatus of claim 10, wherein the tubular support member further comprises:

an expansion cone support body coupled to the first tubular support body comprising:

30

a tapered tubular support member defining N slots;

wherein the adjustable expansion cone assembly comprises:

an expansion cone assembly movably coupled to the tubular support member comprising:

35

a second tubular support body movably coupled to the first tubular support body defining an L-shaped slot; and

N expansion cone segments extending from the second tubular support member, each expansion cone segment comprising:

5 a resilient collet coupled to the second tubular support member;
an expansion cone segment body coupled to the resilient collet including arcuate conical outer surfaces; and

10 a retaining member coupled to the expansion cone segment body for movably coupling the expansion cone segment body to a corresponding one of the slots of the expansion cone support body; and

15 a split ring collar movably coupled to the exterior of the tubular support member comprising:

a third tubular support body;
a first L-shaped retaining member coupled to the third tubular support body for mating with L-shaped slot of the second tubular support body; and

20 a second L-shaped retaining member coupled to the third tubular support body;

wherein the first drag block body further defines:

25 a slot for receiving and mating with the second L-shaped retaining member of the split ring collar.

14. The apparatus of claim 10, wherein the tubular support member further comprises:

30 an expansion cone support body coupled to the tubular support body comprising:

a tapered tubular support member defining N slots;

wherein the adjustable expansion cone assembly comprises:

an expansion cone assembly movably coupled to the tubular support member comprising:

35 a second tubular support body movably coupled to the first tubular support body defining an L-shaped slot; and

N/2 first expansion cone segments extending from the second tubular support member, each first expansion cone segment comprising:

- 5 a first resilient collet coupled to the second tubular support member;
- a first expansion cone segment body coupled to the resilient collet including arcuate conical outer surfaces; and
- 10 a first retaining member coupled to the expansion cone segment body for movably coupling the expansion cone segment body to a corresponding one of the slots of the expansion cone support body;

15 N/2 second expansion cone segments extending from the second tubular support member, each second expansion cone segment comprising:

- a second resilient collet coupled to the second tubular support member;
- 20 a second expansion cone segment body coupled to the resilient collet including arcuate conical outer surfaces; and
- a second retaining member coupled to the expansion cone segment body for movably coupling the expansion cone segment
- 25 body to a corresponding one of the slots of the expansion cone support body;

wherein the second expansion cone segments overlap and are interleaved with the first expansion cone segments; and

- 30 a split ring collar movably coupled to the exterior of the tubular support member comprising:
- a third tubular support body;
- a first L-shaped retaining member coupled to the third tubular support body for mating with the L-shaped slot of the
- 35 second tubular support body; and

a second L-shaped retaining member coupled to the third tubular support body;

wherein the first drag block body further defines:

a slot for receiving and mating with the second L-shaped retaining member of the split ring collar.

5

15. The apparatus of claim 10, wherein the tubular support member further comprises:

an expansion cone support body coupled to the first tubular support body comprising:

10

an N-sided tapered tubular support member;

wherein each side of the multi-sided tapered tubular support member defines a T-shaped slot;

wherein the adjustable expansion cone assembly comprises:

15

$N/2$ first expansion cone segments movably coupled to the expansion cone support body, each comprising:

a first expansion cone segment body including arcuate conical outer surfaces;

20

a first T-shaped retaining member coupled to the first expansion cone segment body for movably coupling the first expansion cone segment body to a corresponding one of the T-shaped slots of the expansion cone support body; and

25

a second T-shaped retaining member coupled to the first expansion cone segment body;

$N/2$ second expansion cone segments movably coupled to the expansion cone support body, each comprising:

a second expansion cone segment body including arcuate conical outer surfaces;

30

a third T-shaped retaining member coupled to the second expansion cone segment body for movably coupling the second expansion cone segment body to a corresponding one of the T-shaped slots of the expansion cone support body; and

35

a fourth T-shaped retaining member coupled to the expansion cone segment body;

wherein the first and second expansion cone segments are interleaved;
 wherein the first expansion cone segment bodies are complementary
 shaped with respect to the second expansion cone segment
 bodies; and

5 a split ring collar assembly movably coupled to the exterior of the tubular
 support member comprising:

a second tubular support body defining:

10 N T-shaped slots for movably receiving corresponding
 ones of the second and fourth T-shaped retaining
 members of the interleaved first and second
 expansion cone segments; and

an L-shaped retaining member coupled to the second tubular
 support body; and

wherein the first drag block body further defines:

15 a slot for receiving and mating with the L-shaped retaining member of
 the split ring collar.

16. An apparatus for radially expanding a tubular member, comprising:

a tubular support member comprising:

20 a first tubular support body defining a longitudinal passage;

a first flange coupled to the first tubular support body;

a second flange coupled to the first tubular support body;

a first tapered flange coupled to the first tubular support body; and

25 a second tapered flange coupled to the first tubular support body;

an adjustable expansion cone assembly movably coupled to the tubular support
 member;

a first collet assembly movably coupled to the tubular support member that
 comprises:

30 a first tubular sleeve coupled to the adjustable expansion cone
 assembly and defining:

a first counterbore for receiving the first flange; and

a first radial passage;

a first spring received within the first counterbore;

a first retaining ring received within the first counterbore;

35 a first load transfer pin coupled to the first retaining ring and extending
 through the first radial passage;

- a second tubular sleeve coupled to the first load transfer pin;
a first resilient collet coupled to the second tubular sleeve and
positioned above the first tapered flange; and
a third tubular sleeve coupled to the first resilient collet;
- 5 a second collet assembly movably coupled to the tubular support member that
comprises:
a fourth tubular sleeve defining:
a second counterbore for receiving the second flange; and
a second radial passage;
- 10 a second spring received within the second counterbore;
a second retaining ring received within the second counterbore;
a second load transfer pin coupled to the second retaining ring and
extending through the second radial passage;
- 15 a fifth tubular sleeve coupled to the second load transfer pin;
a second resilient collet coupled to the fifth tubular sleeve and
positioned above the second tapered flange; and
a sixth tubular sleeve coupled to the second resilient collet; and
first and second packer cups coupled to the tubular support member between
the first and second collet assemblies.
- 20
17. The apparatus of claim 16, wherein the tubular support member further
comprises:
an expansion cone support body coupled to the first tubular support body
comprising:
- 25 an N-sided tapered tubular support member;
wherein each side of the multi-sided tapered tubular support
member defines a T-shaped slot;
- wherein the adjustable expansion cone assembly comprises:
N expansion cone segments movably coupled to the expansion cone
support body, each comprising:
- 30 an expansion cone segment body including arcuate conical outer
surfaces;
a first T-shaped retaining member coupled to the expansion
cone segment body for movably coupling the expansion
cone segment body to a corresponding one of the T-
shaped slots of the expansion cone support body; and
- 35

a second T-shaped retaining member coupled to the expansion cone segment body; and
a split ring collar movably coupled to the exterior of the tubular support member comprising:

5

a second tubular support body defining:

N T-shaped slots for movably receiving corresponding ones of the second T-shaped retaining members of the expansion cone segments; and

10

an L-shaped retaining member coupled to the second tubular support body; and

wherein the first tubular sleeve of the first collet assembly further defines:

a slot for receiving and mating with the L-shaped retaining member of the split ring collar.

15

18. The apparatus of claim 16, wherein the tubular support member further comprises:

an expansion cone support body coupled to the tubular support body comprising:

20

a tapered tubular support member defining N stepped slots;

wherein the adjustable expansion cone assembly comprises:

an expansion cone assembly movably coupled to the tubular support member comprising:

25

a second tubular support body movably coupled to the first tubular support body defining an L-shaped slot; and

N expansion cone segments extending from the second tubular support member, each expansion cone segment comprising:

30

a resilient collet coupled to the second tubular support member;

an expansion cone segment body coupled to the resilient collet including arcuate conical outer surfaces; and

35

a retaining member coupled to the expansion cone segment body for movably coupling the expansion cone segment body to a

corresponding one of the stepped slots of
the expansion cone support body; and
a split ring collar movably coupled to the exterior of the tubular support
member comprising:

5

a third tubular support body:

a first L-shaped retaining member coupled to the third tubular
support body for mating with the L-shaped slot of the
second tubular support body; and

10

a second L-shaped retaining member coupled to the third tubular
support member;

wherein the first tubular sleeve of the first collet assembly further defines:
a slot for receiving and mating with the second L-shaped retaining
member of the split ring collar.

15

19. The apparatus of claim 16, wherein the tubular support member further
comprises:

an expansion cone support body coupled to the first tubular support body
comprising:

a tapered tubular support member defining N slots;

20

wherein the adjustable expansion cone assembly comprises:

an expansion cone assembly movably coupled to the tubular support
member comprising:

a second tubular support body movably coupled to the first
tubular support body defining an L-shaped slot; and

25

N expansion cone segments extending from the second tubular
support member, each expansion cone segment
comprising:

a resilient collet coupled to the second tubular
support member;

30

an expansion cone segment body coupled to the
resilient collet including arcuate conical
outer surfaces; and

35

a retaining member coupled to the expansion
cone segment body for movably coupling
the expansion cone segment body to a

corresponding one of the slots of the
expansion cone support body; and
a split ring collar movably coupled to the exterior of the tubular support
member comprising:

5

a third tubular support body;

a first L-shaped retaining member coupled to the third tubular
support body for mating with L-shaped slot of the second
tubular support body; and

10

a second L-shaped retaining member coupled to the third tubular
support body;

wherein the first tubular sleeve of the first collet assembly further defines:
a slot for receiving and mating with the second L-shaped retaining
member of the split ring collar.

15

20. The apparatus of claim 16, wherein the tubular support member further
comprises:

an expansion cone support body coupled to the tubular support body
comprising:

a tapered tubular support member defining N slots;

20

wherein the adjustable expansion cone assembly comprises:

an expansion cone assembly movably coupled to the tubular support
member comprising:

a second tubular support body movably coupled to the first
tubular support body defining an L-shaped slot; and

25

N/2 first expansion cone segments extending from the second
tubular support member, each first expansion cone
segment comprising:

a first resilient collet coupled to the second tubular
support member;

30

a first expansion cone segment body coupled to
the resilient collet including arcuate conical
outer surfaces; and

a first retaining member coupled to the expansion
cone segment body for movably coupling
the expansion cone segment body to a

35

corresponding one of the slots of the expansion cone support body;

N/2 second expansion cone segments extending from the second tubular support member, each second expansion cone segment comprising:

5

a second resilient collet coupled to the second tubular support member;

10

a second expansion cone segment body coupled to the resilient collet including arcuate conical outer surfaces; and

15

a second retaining member coupled to the expansion cone segment body for movably coupling the expansion cone segment body to a corresponding one of the slots of the expansion cone support body;

wherein the second expansion cone segments overlap and are interleaved with the first expansion cone segments; and

20

a split ring collar movably coupled to the exterior of the tubular support member comprising:

a third tubular support body;

a first L-shaped retaining member coupled to the third tubular support body for mating with the L-shaped slot of the second tubular support body; and

25

a second L-shaped retaining member coupled to the third tubular support body;

wherein the first tubular sleeve of the first collet assembly further defines:

a slot for receiving and mating with the second L-shaped retaining member of the split ring collar.

30

21. The apparatus of claim 16, wherein the tubular support member further comprises:

an expansion cone support body coupled to the first tubular support body comprising:

35

an N-sided tapered tubular support member;

wherein each side of the multi-sided tapered tubular support member defines a T-shaped slot;

wherein the adjustable expansion cone assembly comprises:

N/2 first expansion cone segments movably coupled to the expansion cone support body, each comprising:

5

a first expansion cone segment body including arcuate conical outer surfaces;

a first T-shaped retaining member coupled to the first expansion cone segment body for movably coupling the first

10

expansion cone segment body to a corresponding one of the T-shaped slots of the expansion cone support body;

and

a second T-shaped retaining member coupled to the first expansion cone segment body;

15

N/2 second expansion cone segments movably coupled to the expansion cone support body, each comprising:

a second expansion cone segment body including arcuate conical outer surfaces;

a third T-shaped retaining member coupled to the second expansion cone segment body for movably coupling the

20

second expansion cone segment body to a corresponding one of the T-shaped slots of the expansion cone support body; and

a fourth T-shaped retaining member coupled to the expansion cone segment body;

25

wherein the first and second expansion cone segments are interleaved;

wherein the first expansion cone segment bodies are complementary shaped with respect to the second expansion cone segment bodies; and

30

a split ring collar assembly movably coupled to the exterior of the tubular support member comprising:

a second tubular support body defining:

N T-shaped slots for movably receiving corresponding ones of the second and fourth T-shaped retaining

35

members of the interleaved first and second expansion cone segments; and

an L-shaped retaining member coupled to the second tubular support body; and

wherein the first tubular sleeve of the first collet assembly further defines:

a slot for receiving and mating with the L-shaped retaining member of the split ring collar.

5

22. An apparatus for radially expanding a tubular member, comprising:

a tubular support member comprising:

a first tubular support body defining a longitudinal passage;

10

a first radial passage defined in the first tubular support body fluidically coupled to the longitudinal passage;

a first flange coupled to the first tubular support body;

a second flange coupled to the first tubular support body;

a first tapered flange coupled to the first tubular support body; and

15

a second tapered flange coupled to the first tubular support body;

an adjustable expansion cone assembly movably coupled to the tubular support member;

a first dog assembly movably coupled to the tubular support member that comprises:

20

a first tubular sleeve coupled to the adjustable expansion cone assembly defining:

a first counterbore for receiving the first flange; and

a second radial passage;

a first spring received within the first counterbore;

25

a first retaining ring received within the first counterbore;

a first load transfer pin coupled to the first retaining ring and extending through the second radial passage;

a second tubular sleeve coupled to the first load transfer pin defining:

a second counterbore for receiving the first tubular sleeve;

30

a first resilient dog coupled to the second tubular sleeve and positioned adjacent to the first tapered flange;

a second dog assembly movably coupled to the tubular support member that comprises:

a third tubular sleeve defining:

35

a second counterbore for receiving the second flange;

a third radial passage; and

a fourth radial passage fluidically coupled to the first radial passage;

a second spring received within the second counterbore;

a second retaining ring received within the second counterbore;

5 a second load transfer pin coupled to the second retaining ring and extending through the third radial passage;

a fourth tubular sleeve coupled to the second load transfer pin;

a second resilient dog coupled to the fourth tubular sleeve and positioned adjacent to the second tapered flange; and

10 first and second packer cups coupled to the tubular support member between the first and second dog assemblies.

23. The apparatus of claim 22, wherein the tubular support member further comprises:

15 an expansion cone support body coupled to the first tubular support body comprising:

an N-sided tapered tubular support member;

wherein each side of the multi-sided tapered tubular support member defines a T-shaped slot;

20 wherein the adjustable expansion cone assembly comprises:

N expansion cone segments movably coupled to the expansion cone support body, each comprising:

an expansion cone segment body including arcuate conical outer surfaces;

25 a first T-shaped retaining member coupled to the expansion cone segment body for movably coupling the expansion cone segment body to a corresponding one of the T-shaped slots of the expansion cone support body; and

a second T-shaped retaining member coupled to the expansion cone segment body; and

30 a split ring collar movably coupled to the exterior of the tubular support member comprising:

a second tubular support body defining:

N T-shaped slots for movably receiving corresponding

35 ones of the second T-shaped retaining members of the expansion cone segments; and

an L-shaped retaining member coupled to the second tubular support body; and

wherein the first tubular sleeve of the first dog assembly further defines:

a slot for receiving and mating with the L-shaped retaining member of the split ring collar.

5

24. The apparatus of claim 22, wherein the tubular support member further comprises:

an expansion cone support body coupled to the tubular support body

10

comprising:

a tapered tubular support member defining N stepped slots;

wherein the adjustable expansion cone assembly comprises:

an expansion cone assembly movably coupled to the tubular support member comprising:

15

a second tubular support body movably coupled to the first tubular support body defining an L-shaped slot; and

N expansion cone segments extending from the second tubular support member, each expansion cone segment comprising:

20

a resilient collet coupled to the second tubular support member;

an expansion cone segment body coupled to the resilient collet including arcuate conical outer surfaces; and

25

a retaining member coupled to the expansion cone segment body for movably coupling the expansion cone segment body to a corresponding one of the stepped slots of the expansion cone support body; and

30

a split ring collar movably coupled to the exterior of the tubular support member comprising:

a third tubular support body:

a first L-shaped retaining member coupled to the third tubular support body for mating with the L-shaped slot of the second tubular support body; and

35

a second L-shaped retaining member coupled to the third tubular support member; and

wherein the first tubular sleeve of the first dog assembly further defines:

a slot for receiving and mating with the second L-shaped retaining member of the split ring collar.

5

25. The apparatus of claim 22, wherein the tubular support member further comprises:

an expansion cone support body coupled to the first tubular support body comprising:

10

a tapered tubular support member defining N slots;

wherein the adjustable expansion cone assembly comprises:

an expansion cone assembly movably coupled to the tubular support member comprising:

15

a second tubular support body movably coupled to the first tubular support body defining an L-shaped slot; and
N expansion cone segments extending from the second tubular support member, each expansion cone segment comprising:

20

a resilient collet coupled to the second tubular support member;

an expansion cone segment body coupled to the resilient collet including arcuate conical outer surfaces; and

25

a retaining member coupled to the expansion cone segment body for movably coupling the expansion cone segment body to a corresponding one of the slots of the expansion cone support body; and

30

a split ring collar movably coupled to the exterior of the tubular support member comprising:

a third tubular support body;

a first L-shaped retaining member coupled to the third tubular support body for mating with L-shaped slot of the second tubular support body; and

35

a second L-shaped retaining member coupled to the third tubular support body; and

wherein the first tubular sleeve of the first dog assembly further defines:
a slot for receiving and mating with the second L-shaped retaining member of the split ring collar.

5

26. The apparatus of claim 22, wherein the tubular support member further comprises:

an expansion cone support body coupled to the tubular support body comprising:

10

a tapered tubular support member defining N slots;

wherein the adjustable expansion cone assembly comprises:

an expansion cone assembly movably coupled to the tubular support member comprising:

15

a second tubular support body movably coupled to the first tubular support body defining an L-shaped slot; and
N/2 first expansion cone segments extending from the second tubular support member, each first expansion cone segment comprising:

20

a first resilient collet coupled to the second tubular support member;

a first expansion cone segment body coupled to the resilient collet including arcuate conical outer surfaces; and

25

a first retaining member coupled to the expansion cone segment body for movably coupling the expansion cone segment body to a corresponding one of the slots of the expansion cone support body;

30

N/2 second expansion cone segments extending from the second tubular support member, each second expansion cone segment comprising:

a second resilient collet coupled to the second tubular support member;

a second expansion cone segment body coupled
 to the resilient collet including arcuate
 conical outer surfaces; and
 a second retaining member coupled to the
 5 expansion cone segment body for movably
 coupling the expansion cone segment
 body to a corresponding one of the slots of
 the expansion cone support body;
 wherein the second expansion cone segments overlap
 10 and are interleaved with the first expansion cone
 segments; and
 a split ring collar movably coupled to the exterior of the tubular support
 member comprising:
 a third tubular support body;
 15 a first L-shaped retaining member coupled to the third tubular
 support body for mating with the L-shaped slot of the
 second tubular support body; and
 a second L-shaped retaining member coupled to the third tubular
 support body; and
 20 wherein the first tubular sleeve of the first dog assembly further defines:
 a slot for receiving and mating with the second L-shaped retaining
 member of the split ring collar.

27. The apparatus of claim 22, wherein the tubular support member further
 25 comprises:

an expansion cone support body coupled to the first tubular support body
 comprising:
 an N-sided tapered tubular support member;
 wherein each side of the multi-sided tapered tubular support
 30 member defines a T-shaped slot;
 wherein the adjustable expansion cone assembly comprises:
 N/2 first expansion cone segments movably coupled to the expansion
 cone support body, each comprising:
 a first expansion cone segment body including arcuate conical
 35 outer surfaces;

5 a first T-shaped retaining member coupled to the first expansion
cone segment body for movably coupling the first
expansion cone segment body to a corresponding one of
the T-shaped slots of the expansion cone support body;
and
a second T-shaped retaining member coupled to the first
expansion cone segment body;
N/2 second expansion cone segments movably coupled to the
expansion cone support body, each comprising:
10 a second expansion cone segment body including arcuate
conical outer surfaces;
a third T-shaped retaining member coupled to the second
expansion cone segment body for movably coupling the
second expansion cone segment body to a
15 corresponding one of the T-shaped slots of the expansion
cone support body; and
a fourth T-shaped retaining member coupled to the expansion
cone segment body;
wherein the first and second expansion cone segments are interleaved;
20 wherein the first expansion cone segment bodies are complementary
shaped with respect to the second expansion cone segment
bodies; and
a split ring collar assembly movably coupled to the exterior of the tubular
support member comprising:
25 a second tubular support body defining:
N T-shaped slots for movably receiving corresponding
ones of the second and fourth T-shaped retaining
members of the interleaved first and second
expansion cone segments; and
30 an L-shaped retaining member coupled to the second tubular
support body; and
wherein the first tubular sleeve of the first dog assembly further defines:
a slot for receiving and mating with the L-shaped retaining member of
the split ring collar.

35

28. An apparatus for radially expanding a tubular member, comprising:

a tubular support member comprising:

a first tubular support body defining a longitudinal passage including a throat passage;

5

a first radial passage defined in the first tubular support body fluidically coupled to the longitudinal passage;

a first flange coupled to the first tubular support body;

a second flange coupled to the first tubular support body defining:

a second radial passage defined in the second flange fluidically coupled to the longitudinal passage; and

10

an adjustable expansion cone assembly movably coupled to the tubular support member;

a dog assembly movably coupled to the tubular support member that comprises:

15

a first tubular sleeve coupled to the adjustable expansion cone assembly defining:

a first counterbore for receiving the first flange; and
a third radial passage;

a spring received within the first counterbore;

a retaining ring received within the first counterbore;

20

a load transfer pin coupled to the retaining ring and extending through the third radial passage;

a second tubular sleeve coupled to the first load transfer pin that defines:

25

a first counterbore for receiving the first tubular sleeve;
a second counterbore for receiving and mating with the tapered flange; and

comprises:

a third flange defining:

30

a third counterbore for receiving the second flange;

a fourth counterbore for receiving the second flange; and

a fourth radial passage; and

35

a resilient dog coupled to the second tubular sleeve and positioned adjacent to the tapered flange; and

first and second packer cups coupled to the tubular support member between the resilient dog and the third flange.

29. The apparatus of claim 28, wherein the tubular support member further
5 comprises:
an expansion cone support body coupled to the first tubular support body
comprising:
an N-sided tapered tubular support member;
wherein each side of the multi-sided tapered tubular support
10 member defines a T-shaped slot;
wherein the adjustable expansion cone assembly comprises:
N expansion cone segments movably coupled to the expansion cone
support body, each comprising:
an expansion cone segment body including arcuate conical outer
15 surfaces;
a first T-shaped retaining member coupled to the expansion
cone segment body for movably coupling the expansion
cone segment body to a corresponding one of the T-
shaped slots of the expansion cone support body; and
20 a second T-shaped retaining member coupled to the expansion
cone segment body; and
a split ring collar movably coupled to the exterior of the tubular support
member comprising:
a second tubular support body defining:
25 N T-shaped slots for movably receiving corresponding
ones of the second T-shaped retaining members
of the expansion cone segments; and
an L-shaped retaining member coupled to the second tubular
support body; and
30 wherein the first tubular sleeve of the dog assembly further defines:
a slot for receiving and mating with the L-shaped retaining member of
the split ring collar.

30. The apparatus of claim 28, wherein the tubular support member further
35 comprises:

an expansion cone support body coupled to the tubular support body

comprising:

a tapered tubular support member defining N stepped slots;

wherein the adjustable expansion cone assembly comprises:

5 an expansion cone assembly movably coupled to the tubular support member comprising:

a second tubular support body movably coupled to the first tubular support body defining an L-shaped slot; and

10 N expansion cone segments extending from the second tubular support member, each expansion cone segment comprising:

a resilient collet coupled to the second tubular support member;

15 an expansion cone segment body coupled to the resilient collet including arcuate conical outer surfaces; and

20 a retaining member coupled to the expansion cone segment body for movably coupling the expansion cone segment body to a corresponding one of the stepped slots of the expansion cone support body; and

a split ring collar movably coupled to the exterior of the tubular support member comprising:

a third tubular support body:

25 a first L-shaped retaining member coupled to the third tubular support body for mating with the L-shaped slot of the second tubular support body; and

a second L-shaped retaining member coupled to the third tubular support member; and

30 wherein the first tubular sleeve of the dog assembly further defines:

a slot for receiving and mating with the second L-shaped retaining member of the split ring collar.

31. The apparatus of claim 28, wherein the tubular support member further
35 comprises:

an expansion cone support body coupled to the first tubular support body comprising:

a tapered tubular support member defining N slots;

wherein the adjustable expansion cone assembly comprises:

5 an expansion cone assembly movably coupled to the tubular support member comprising:

a second tubular support body movably coupled to the first tubular support body defining an L-shaped slot; and

10 N expansion cone segments extending from the second tubular support member, each expansion cone segment comprising:

a resilient collet coupled to the second tubular support member;

15 an expansion cone segment body coupled to the resilient collet including arcuate conical outer surfaces; and

20 a retaining member coupled to the expansion cone segment body for movably coupling the expansion cone segment body to a corresponding one of the slots of the expansion cone support body; and

a split ring collar movably coupled to the exterior of the tubular support member comprising:

a third tubular support body;

25 a first L-shaped retaining member coupled to the third tubular support body for mating with L-shaped slot of the second tubular support body; and

a second L-shaped retaining member coupled to the third tubular support body; and

30 wherein the first tubular sleeve of the dog assembly further defines:

a slot for receiving and mating with the second L-shaped retaining member of the split ring collar.

32. The apparatus of claim 28, wherein the tubular support member further
35 comprises:

an expansion cone support body coupled to the tubular support body
comprising:

a tapered tubular support member defining N slots;

wherein the adjustable expansion cone assembly comprises:

5 an expansion cone assembly movably coupled to the tubular support
member comprising:

a second tubular support body movably coupled to the first
tubular support body defining an L-shaped slot; and

10 N/2 first expansion cone segments extending from the second
tubular support member, each first expansion cone
segment comprising:

a first resilient collet coupled to the second tubular
support member;

15 a first expansion cone segment body coupled to
the resilient collet including arcuate conical
outer surfaces; and

20 a first retaining member coupled to the expansion
cone segment body for movably coupling
the expansion cone segment body to a
corresponding one of the slots of the
expansion cone support body;

N/2 second expansion cone segments extending from the
second tubular support member, each second expansion
cone segment comprising:

25 a second resilient collet coupled to the second
tubular support member;

a second expansion cone segment body coupled
to the resilient collet including arcuate
conical outer surfaces; and

30 a second retaining member coupled to the
expansion cone segment body for movably
coupling the expansion cone segment
body to a corresponding one of the slots of
the expansion cone support body;

- wherein the second expansion cone segments overlap
and are interleaved with the first expansion cone
segments; and
a split ring collar movably coupled to the exterior of the tubular support
5 member comprising:
a third tubular support body;
a first L-shaped retaining member coupled to the third tubular
support body for mating with the L-shaped slot of the
second tubular support body; and
10 a second L-shaped retaining member coupled to the third tubular
support body; and
wherein the first tubular sleeve of the dog assembly further defines:
a slot for receiving and mating with the second L-shaped retaining
member of the split ring collar.
15
33. The apparatus of claim 28, wherein the tubular support member further
comprises:
an expansion cone support body coupled to the first tubular support body
comprising:
20 an N-sided tapered tubular support member;
wherein each side of the multi-sided tapered tubular support
member defines a T-shaped slot;
wherein the adjustable expansion cone assembly comprises:
N/2 first expansion cone segments movably coupled to the expansion
25 cone support body, each comprising:
a first expansion cone segment body including arcuate conical
outer surfaces;
a first T-shaped retaining member coupled to the first expansion
cone segment body for movably coupling the first
30 expansion cone segment body to a corresponding one of
the T-shaped slots of the expansion cone support body;
and
a second T-shaped retaining member coupled to the first
expansion cone segment body;
35 N/2 second expansion cone segments movably coupled to the
expansion cone support body, each comprising:

- a second expansion cone segment body including arcuate conical outer surfaces;
- a third T-shaped retaining member coupled to the second expansion cone segment body for movably coupling the second expansion cone segment body to a corresponding one of the T-shaped slots of the expansion cone support body; and
- a fourth T-shaped retaining member coupled to the expansion cone segment body;
- wherein the first and second expansion cone segments are interleaved; wherein the first expansion cone segment bodies are complementary shaped with respect to the second expansion cone segment bodies; and
- a split ring collar assembly movably coupled to the exterior of the tubular support member comprising:
- a second tubular support body defining:
- N T-shaped slots for movably receiving corresponding ones of the second and fourth T-shaped retaining members of the interleaved first and second expansion cone segments; and
- an L-shaped retaining member coupled to the second tubular support body; and
- wherein the first tubular sleeve of the dog assembly further defines:
- a slot for receiving and mating with the L-shaped retaining member of the split ring collar.
34. An apparatus for radially expanding a tubular member, comprising:
- a tubular support member;
- an adjustable expansion cone assembly movably coupled to the tubular support member; and
- means for adjusting the adjustable expansion cone assembly.
35. The apparatus of claim 34, wherein the means for adjusting the adjustable expansion cone assembly comprises:
- frictional means for adjusting the adjustable expansion cone assembly.

36. The apparatus of claim 34, wherein the means for adjusting the adjustable expansion cone assembly comprises:
resilient means for adjusting the adjustable expansion cone assembly.
- 5 37. An adjustable expansion cone assembly, comprising:
a tubular support member;
an adjustable expansion cone movably coupled to the tubular support member,
comprising:
a plurality of expansion cone segments; and
10 means for guiding the expansion cone segments on the tubular support
member; and
means for adjusting the adjustable expansion cone.
38. The adjustable expansion cone assembly of claim 37, wherein the adjustable
15 expansion cone further comprises:
means for interlocking the expansion cone segments.
39. The adjustable expansion cone assembly of claim 37, wherein the means for
adjusting the adjustable expansion cone comprises:
20 resilient means for supporting the expansion cone segments.
40. The adjustable expansion cone assembly of claim 37, wherein the expansion
cone segments include first and second interleaved groups of expansion cone
segments.
25
41. The adjustable expansion cone assembly of claim 40, wherein the means for
adjusting the adjustable expansion cone comprises:
means for displacing the first and second interleaved groups of expansion cone
segments in opposite directions.
30
42. A method of operating an adjustable expansion cone assembly comprising a
plurality of expansion cone segments, comprising:
guiding the expansion cone segments on a tapered body; and
controllably displacing the expansion cone segments along the tapered body.
35
43. The method of claim 42, further comprising:

resiliently guiding the expansion cone segments on the tapered body.

44. The method of claim 42, further comprising:
interlocking the expansion cone segments.

5

45. The method of claim 42, further comprising:
dividing the expansion cone segments into first and second groups of
expansion cone segments; and
interleaving the first and second groups of expansion cone segments.

10

46. The method of claim 45, further comprising:
overlapping the first and second groups of expansion cone segments.

47. The method of claim 45, wherein controllably displacing the expansion cone
15 segments along the tapered body comprises:
displacing the first and second interleaved groups of expansion cone segments
in opposite directions.

48. A method of operating an adjustable expansion cone assembly comprising a
20 plurality of expansion cone segments, comprising:

guiding the expansion cone segments on a multi-sided tapered body;
interlocking the expansion cone segments; and
controllably displacing the expansion cone segments along the tapered body.

25

49. A method of operating an adjustable expansion cone assembly comprising a
plurality of expansion cone segments, comprising:
resiliently guiding the expansion cone segments on a multi-sided tapered body;
guiding each of the expansion cone segments on opposite sides in the
30 circumferential direction;
interlocking the expansion cone segments; and
controllably displacing the expansion cone segments along the tapered body.

50. A method of operating an adjustable expansion cone assembly comprising a
35 plurality of expansion cone segments, comprising:

dividing the expansion cone segments into first and second groups of expansion cone segments;
interleaving the first and second groups of expansion cone segments;
overlapping the first and second groups of expansion cone segments;
5 resiliently guiding the expansion cone segments on a multi-sided tapered body;
guiding each of the expansion cone segments on opposite sides in the circumferential direction; and
controllably displacing the expansion cone segments along the tapered body.

10

51. A method of operating an adjustable expansion cone assembly comprising a plurality of expansion cone segments, comprising:

dividing the expansion cone segments into first and second groups of expansion cone segments;

15

interleaving the first and second groups of expansion cone segments;
guiding the expansion cone segments on a multi-sided tapered body; and
controllably displacing the expansion cone segments along the tapered body while also relatively displacing the first and second groups of expansion cone segments in opposite directions.

20

52. A method of plastically deforming and radially expanding an expandable tubular member using an apparatus comprising a tubular support member, an adjustable expansion cone assembly movably coupled to the tubular support member, and an actuator movably coupled to the tubular support member for adjusting the adjustable expansion cone assembly, comprising:

25

coupling a first end of the expandable tubular member to a tubular structure;
locking the actuator to the tubular support member of the apparatus;

inserting the apparatus into the first end of the expandable tubular member;
moving the actuator and the adjustable expansion cone assembly of the

30

apparatus out of the second end of the expandable tubular member;
reinserting the actuator of the apparatus into the second end of the expandable tubular member;

unlocking the actuator from the tubular support member of the apparatus;

rotating the actuator relative to the tubular support member of the apparatus;

35

and

- increasing the outside diameter of the adjustable expansion cone assembly by moving the tubular support member relative to the actuator, the adjustable expansion cone assembly, and the expandable tubular member; and
- 5 plastically deforming and radially expanding the expandable tubular member by moving the adjustable expansion cone assembly through the expandable tubular member.
53. The method of claim 52, wherein the tubular support member includes one or
10 more lugs; wherein the actuator includes one or more corresponding retaining slots; and wherein locking comprises positioning the lugs into the corresponding retaining slots.
54. The method of claim 52, wherein the tubular support member includes one or
15 more lugs; wherein the actuator includes one or more corresponding retaining slots; and wherein unlocking comprises positioning the lugs out of engagement with corresponding retaining slots.
55. The method of claim 52, wherein moving the tubular support member relative to
20 the actuator, the adjustable expansion cone assembly, and the expandable tubular member comprises:
the actuator frictionally engaging the expandable tubular member.
56. The method of claim 52, wherein moving the adjustable expansion cone
25 assembly through the expandable tubular member comprises:
pulling the adjustable expansion cone through the expandable tubular member.
57. The method of claim 52, further comprising:
fluidically sealing the interface between the tubular support member of the
30 apparatus and the expandable tubular member;
wherein moving the adjustable expansion cone assembly through the expandable tubular member comprises:
injecting a pressurized fluid into the tubular support member.
- 35 58. A method of plastically deforming and radially expanding an expandable tubular member using an apparatus comprising a tubular support member, an adjustable

expansion cone assembly movably coupled to the tubular support member, and an actuator movably coupled to the tubular support member for adjusting the adjustable expansion cone assembly, comprising:

- 5 coupling a first end of the expandable tubular member to a tubular structure;
 inserting the apparatus into the first end of the expandable tubular member in a
 first direction;
 displacing the actuator of the apparatus in a second direction opposite to the
 first direction;
 applying a resilient biasing force to the adjustable expansion cone assembly in
10 the second direction;
 moving the actuator and the adjustable expansion cone assembly of the
 apparatus out of the second end of the expandable tubular member;
 reinserting the actuator of the apparatus into the second end of the expandable
 tubular member in the second direction;
15 increasing the outside diameter of the adjustable expansion cone assembly by
 displacing the actuator and the adjustable expansion cone assembly
 relative to the expandable tubular member in the first direction; and
 plastically deforming and radially expanding the expandable tubular member by
 moving the adjustable expansion cone assembly through the
20 expandable tubular member in the second direction.

59. The method of claim 58, wherein displacing the actuator of the apparatus in the second direction comprises:

- 25 impacting the actuator with the first end of the expandable tubular member.

60. The method of claim 58, wherein displacing the actuator and the adjustable expansion cone assembly relative to the expandable tubular member in the first direction comprises:

- 30 impacting the actuator with the second end of the expandable tubular member.

61. The method of claim 58, wherein moving the adjustable expansion cone assembly through the expandable tubular member comprises:

- pulling the adjustable expansion cone through the expandable tubular member.

35 62. The method of claim 58, further comprising:

fluidicly sealing the interface between the tubular support member of the apparatus and the expandable tubular member; wherein moving the adjustable expansion cone assembly through the expandable tubular member comprises:

5 injecting a pressurized fluid into the tubular support member.

63. An adjustable expansion cone assembly, comprising:

a plurality of expansion cone segments;

means for guiding the expansion cone segments on a tapered body; and

10 means for controllably displacing the expansion cone segments along the tapered body.

64. The assembly of claim 63, further comprising:

15 means for resiliently guiding the expansion cone segments on the tapered body.

65. The assembly of claim 63, further comprising:

means for interlocking the expansion cone segments.

20 66. The assembly of claim 63, further comprising:

means for dividing the expansion cone segments into first and second groups of expansion cone segments; and

means for interleaving the first and second groups of expansion cone segments.

25

67. The assembly of claim 66, further comprising:

means for overlapping the first and second groups of expansion cone segments.

30 68. The assembly of claim 66, wherein the means for controllably displacing the expansion cone segments along the tapered body comprises:

means for displacing the first and second interleaved groups of expansion cone segments in opposite directions.

35 69. An adjustable expansion cone assembly, comprising:

a plurality of expansion cone segments;

means for guiding the expansion cone segments on a multi-sided tapered body;
means for interlocking the expansion cone segments; and
means for controllably displacing the expansion cone segments along the tapered body.

5

70. An adjustable expansion cone assembly, comprising:

a plurality of expansion cone segments;

means for resiliently guiding the expansion cone segments on a multi-sided tapered body;

10

means for guiding each of the expansion cone segments on opposite sides in the circumferential direction;

means for interlocking the expansion cone segments; and

means for controllably displacing the expansion cone segments along the tapered body.

15

71. An adjustable expansion cone assembly, comprising:

a plurality of expansion cone segments;

means for dividing the expansion cone segments into first and second groups of expansion cone segments;

20

means for interleaving the first and second groups of expansion cone segments;

means for overlapping the first and second groups of expansion cone segments;

25

means for resiliently guiding the expansion cone segments on a multi-sided tapered body;

means for guiding each of the expansion cone segments on opposite sides in the circumferential direction; and

means for controllably displacing the expansion cone segments along the tapered body.

30

72. An adjustable expansion cone assembly, comprising:

a plurality of expansion cone segments;

means for dividing the expansion cone segments into first and second groups of expansion cone segments;

35

means for interleaving the first and second groups of expansion cone segments;

means for guiding the expansion cone segments on a multi-sided tapered body;
and

means for controllably displacing the expansion cone segments along the
tapered body while also relatively displacing the first and second groups
of expansion cone segments in opposite directions.

5

73. An apparatus for plastically deforming and radially expanding an expandable
tubular member, comprising:

a tubular support member;

10

an adjustable expansion cone assembly movably coupled to the tubular support
member;

means for actuating the adjustable expansion cone assembly;

means for locking the actuator to the tubular support member of the apparatus;

means for unlocking the actuator from the tubular support member of the
apparatus;

15

means for increasing the outside diameter of the adjustable expansion cone
assembly by moving the tubular support member relative to the actuator,
the adjustable expansion cone assembly, and the expandable tubular
member.

20

74. The apparatus of claim 73, wherein the tubular support member includes one or
more lugs; wherein the actuator includes one or more corresponding retaining slots;
and wherein the means for locking comprises positioning the lugs into the
corresponding retaining slots.

25

75. The apparatus of claim 73, wherein the tubular support member includes one or
more lugs; wherein the actuator includes one or more corresponding retaining slots;
and wherein the means for unlocking comprises positioning the lugs out of engagement
with corresponding retaining slots.

30

76. The method of claim 73, further comprising:

means for fluidically sealing the interface between the tubular support member of
the apparatus and the expandable tubular member.

35

77. An apparatus for plastically deforming and radially expanding an expandable
tubular member, comprising:

a tubular support member;

an adjustable expansion cone assembly movably coupled to the tubular support member;

means for actuating the adjustable expansion cone assembly;

5 means for displacing the actuator of the apparatus in a first direction;

means for applying a resilient biasing force to the adjustable expansion cone assembly when the actuator is displaced in the first direction;

10 means for increasing the outside diameter of the adjustable expansion cone assembly by displacing the actuator and the adjustable expansion cone assembly relative to the expandable tubular member in a second direction opposite to the first direction.

78. The apparatus of claim 77, wherein the means for displacing the actuator of the apparatus in the first direction comprises:

15 means for impacting the actuator.

79. The apparatus of claim 77, wherein the means for displacing the actuator and the adjustable expansion cone assembly relative to the expandable tubular member in the first direction comprises:

20 means for impacting the actuator.



INVESTOR IN PEOPLE

Application No: GB0512398.9

1

Examiner: David Pepper

Claims searched: 1-5

Date of search: 26 July 2005

Patents Act 1977: Search Report under Section 17

Documents considered to be relevant:

Category	Relevant to claims	Identity of document and passage or figure of particular relevance
A,E	-	WO 2003/016669 A (Enventure Global Technology)
A,P	-	WO 02/059456 A (E2Tech)
&	-	WO 03/023178 A (Enventure Global Technology)
&	-	US 2005/022986 A1 (Enventure Global Technology)

Categories:

X Document indicating lack of novelty or inventive step	A Document indicating technological background and/or state of the art.
Y Document indicating lack of inventive step if combined with one or more other documents of same category.	P Document published on or after the declared priority date but before the filing date of this invention.
& Member of the same patent family	E Patent document published on or after, but with priority date earlier than, the filing date of this application.

Field of Search:

Search of GB, EP, WO & US patent documents classified in the following areas of the UKC^X :

E1F

Worldwide search of patent documents classified in the following areas of the IPC⁰⁷

E21B

The following online and other databases have been used in the preparation of this search report

WPI, EPODOC