

FORM 1
COMMONWEALTH OF AUSTRALIA
PATENTS ACT 1952

APPLICATION FOR A STANDARD PATENT

I\We,
LANTECH, INC.
of 11000 BLUEGRASS PARKWAY
LOUISVILLE
KENTUCKY 40299
USA

hereby apply for the grant of a standard patent for an invention entitled:

PARALLEL BELTED CLAMP

which is described in the accompanying complete specification
Details of basic application(s):

Number of basic application	Name of Convention country in which basic application was filed	Date of basic application
019613	US	27 FEB 87

My/our address for service is care of CLEMENT HACK & CO., Patent Attorneys, 601 St. Kilda Road, Melbourne 3004, Victoria, Australia.

DATED this 15th day of January 1988

LANTECH, INC.

APPLICATION ACCEPTED AND AMENDMENTS

ALLOWED 14-12-89

CLEMENT HACK & CO.

TO: The Commissioner of Patents.

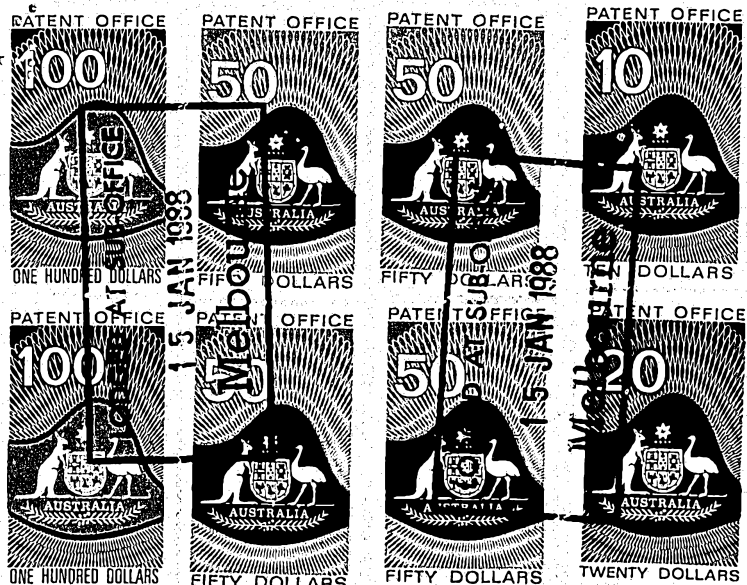

LODGED AT SUB-OFFICE
15 JAN 1988
Melbourne

FEE STAMP TO VALUE OF
4.30 ATTACHED
MAIL OFFICER.....

Forms 7 and 8

AUSTRALIA

Patents Act 1952

DECLARATION IN SUPPORT OF A CONVENTION OR NON-CONVENTION
APPLICATION FOR A PATENT OR PATENT OF ADDITION

Name(s) of
Applicant(s)

In support of the application made by LANTECH, INC.

Title

for a patent for an invention entitled PARALLEL BELTED
CLAMP

Name(s) and
address(es)
of person(s)
making
declaration

I/We, Patrick R. Lancaster
LANTECH, INC
11000 Bluegrass Pkwy
Louisville, KY 40299

do solemnly and sincerely declare as follows:-

1. I am/we are the applicant(s) for the patent, or
am/are authorised by the abovementioned applicant
to make this declaration on its behalf.

2. The basic application(s) as defined by Section 141
of the Act was/were made in the following country
or countries on the following date(s) by the
following applicant(s) namely:-

Country, filing
date and name
of Applicant(s)
for the or
each basic
application

in United States of America on 27th February 1987
by William G. Lancaster
in _____ on _____ 19____
by _____

3. The said basic application(s) was/were the first
application(s) made in a Convention country in respect
of the invention the subject of the application.

Name(s) and
address(es)
of the or
each actual
inventor

4. The actual inventor(s) of the said invention is/are
William G. Lancaster
5101 Upper River Road
Louisville, Kentucky 40222
USA

See reverse
side of this
form for
guidance in
completing

5. The facts upon which the applicant(s) is/are entitled
to make this application are as follows:-

The said applicant is the assignee of the said
inventor

(12) PATENT ABRIDGMENT **(11) Document No. AU-B-10322/88**
(19) AUSTRALIAN PATENT OFFICE **(10) Acceptance No. 593974**

(54) Title
PARALLEL BELTED CLAMP

International Patent Classification(s)
(51)⁴ **F16B 002/08** **B65B 011/02** **F16B 002/12**

(21) Application No. : **10322/88** (22) Application Date : **15.01.88**

(30) Priority Data

(31) Number (32) Date (33) Country
019613 **27.02.87** **US UNITED STATES OF AMERICA**

(43) Publication Date : **01.09.88**

(44) Publication Date of Accepted Application : **22.02.90**

(71) Applicant(s)
LANTECH, INC.

(72) Inventor(s)
WILLIAM G. LANCASTER

(74) Attorney or Agent
GRIFFITH HACK & CO. _MELBOURNE

(56) Prior Art Documents
US 4545182
US 4232501

(57) Claim

1. A clamp comprising:
 - a first longitudinally extending clamp means including first contact means for contacting a workpiece;
 - a second longitudinally extending clamp means extendable in a direction parallel to the longitudinal direction of the first clamp means, the second clamp means including second contact means opposed to the first contact means for contacting the workpiece, the second contact means being supported by a remaining portion of the second clamp means and movable in the longitudinal direction relative to the remaining portion of the second clamp means while being fixed relative to the first contact means for clamping a workpiece between the second contact means and the first contact means as the remaining portion of the second clamp means is longitudinally extended in a direction parallel to the longitudinal direction of the first clamp means.

25. Apparatus for clamping a web and wrapping a load with the web comprising:
means for dispensing the web;
means for rotating the load relative to the dispenser means to wrap the web on the load; and
means for clamping the web including a first longitudinally extending clamp means having first contact means for contacting the web, a second longitudinally extending clamp means extendable in a direction generally parallel to the longitudinal direction of the first clamp means, the second clamp means including second contact means opposed to the first contact means for contacting the workpiece, the second contact means being supported by a remaining portion of the second clamp means and movable in the longitudinal direction relative to the remaining portion of the second clamp means while being fixed relative to the first contact means for clamping the web between the second contact means and the first contact means as the remaining portion of the second clamp means is longitudinally extended in a direction parallel to the longitudinal direction of the first clamp means.

AUSTRALIA

PATENTS ACT 1952

Form 10

COMPLETE SPECIFICATION

(ORIGINAL)

FOR OFFICE USE

593974

Short Title:

Int. Cl:

Application Number:

Lodged:

Complete Specification-Lodged:

Accepted:

Lapsed:

Published:

This document contains the amendments made under Section 49 and is correct for printing.

Priority:

Related Art:

TO BE COMPLETED BY APPLICANT

Name of Applicant:

LANTECH, INC.

Address of Applicant: 11000 BLUEGRASS PARKWAY

LOUISVILLE

KENTUCKY 40299

USA

Actual Inventor:

Address for Service: CLEMENT HACK & CO.,

601 St. Kilda Road,

Melbourne, Victoria 3004,

Australia.

Complete Specification for the invention entitled:

PARALLEL BELTED CLAMP

The following statement is a full description of this invention including the best method of performing it known to me:-

PARALLEL BELTED CLAMP

5 Background of the Invention

The present invention relates to methods and apparatus for clamping and more particularly relates to methods and apparatus for clamping a web and wrapping a load with the web.

10 A wide variety of clamping devices have been developed to accommodate the specialized needs of operations in diverse fields. Such developments have specifically occurred in the field of stretch wrapping, which involves the process of wrapping a load with a web
15 of stretchable material. As stretch wrapping technology

developed and became increasingly automated, clamping arrangements were developed which accommodated and complemented the other features of the operation. Examples of such clamping arrangements for stretch 5 wrapping machines are shown in U.S. Patent Nos. 4,232,501 and 4,300,326 to Stackhouse and 4,317,322 to Lancaster et al., all of which are assigned to Lantech, Inc., and incorporated herein by reference.

Although successful, these arrangements have 10 limitations in positioning and control during the operation of the stretch wrapping equipment.

Accordingly, it is the object of the present invention to provide a clamping arrangement which has less restrictive limitations in positioning and control 15 during stretch wrapping operations than previously known arrangements.

In particular, it is an object of the present invention to provide a clamping arrangement which minimizes lateral movement of the clamp during operation 20 and the space required for such movement.

It is another object of the present invention to provide a clamping arrangement which easily orients itself to the work piece which is clamped.

It is an additional object of the present 25 invention to provide a clamping arrangement which can be easily positioned and removed from a work location without interfering with the other operations of the apparatus.

It is a further object of the present invention 30 to provide a clamping arrangement which smoothly secures a work piece without causing damage.

Additional objects and advantages of the invention will be set forth in the description which follows, and in part will be obvious from the 35 description, or may be learned by practice of the invention. The objects and advantages of the invention

may be realized and obtained by means of the instrumentalities and combinations particularly pointed out in the appended claims.

Summary of the Invention

5 According to the present invention there is provided a clamp comprising:

 a first longitudinally extending clamp means including first contact means for contacting a workpiece; a second longitudinally extending clamp means extendable in a direction parallel to the longitudinal direction of the first clamp means, the second clamp means including second contact means opposed to the first contact means for contacting the workpiece, the second contact means being supported by a remaining portion of 10 the second clamp means and movable in the longitudinal direction relative to the remaining portion of the second clamp means while being fixed relative to the first contact means for clamping a workpiece between the second contact means and the first contact means as the 15 remaining portion of the second clamp means is longitudinally extended in a direction parallel to the longitudinal direction of the first clamp means.

 According to the present invention there is also provided apparatus for clamping a web and wrapping a 25 load with the web comprising:

 means for dispensing the web; means for rotating the load relative to the dispenser means to wrap the web on the load; and means for clamping the web including a first 30 longitudinally extending clamp means having first contact means for contacting the web, a second longitudinally extending clamp means extendable in a direction generally parallel to the longitudinal direction of the first clamp means, the second clamp means including second contact 35 means opposed to the first contact means for contacting



the workpiece, the second contact means being supported by a remaining portion of the second clamp means and movable in the longitudinal direction relative to the remaining portion of the second clamp means while being
5 fixed relative to the first contact means for clamping the web between the second contact means and the first contact means as the remaining portion of the second clamp means is longitudinally extended in a direction parallel to the longitudinal direction of the first clamp
10 means.

According to the present invention there is provided a method for clamping a web and wrapping a load with a web comprising:

positioning a load in a position to be wrapped;
15 rotating the load relative to a web dispenser to wrap the web on the load;

extending a first longitudinally extending clamp element along its longitudinal direction into the wrapping path of the web;

20 passing the web over the first clamp element and contacting the web with a contact portion of the first clamp element; and

extending a second longitudinally extending clamp element along its longitudinal direction in a
25 direction parallel to the first clamp element and contacting the web with a contact portion of the second clamp element while moving the contact portion of the second clamp element in the longitudinal direction relative to a remaining portion of the second clamp
30 element but maintaining the contact portion of the second clamp element fixed relative to contact portion of the first clamp element to clamp the web between the contact portions of the first and second clamp elements as the remaining portion of the second clamp element is
35 longitudinally extended in a direction parallel to the longitudinal direction of the first clamp element.



Brief Description of the Drawings

The accompanying drawings, which are incorporated in and constitute part of the specification, illustrate a presently preferred embodiment of the invention and, together with the general description given above and the detailed description of the preferred embodiment given below, serve to explain the principles of the invention.

Fig. 1 is a perspective view of a clamp
10 incorporating the teachings of the present invention;

Fig. 2 is a front end perspective view of the clamp illustrated in Fig. 1 without a wipedown brush;

Fig. 3 is a front end perspective view of a second embodiment of a clamp according to the teachings
15 of the present invention;

Figs. 4A-4E are schematic left side views of the embodiment shown in Figs. 1 and 2 executing an embodiment of a method incorporating the teachings of the present invention;

20 Figs. 5A-5C are schematic left side views of the embodiment shown in Fig. 3 executing another embodiment of a method incorporating the teachings of the present invention;

Fig. 6 is a right side elevation view of a
25 portion of the embodiment illustrated in Fig. 1 in a slightly different position;

Fig. 7 is a front end section view of an apparatus for clamping a web and wrapping a load with the web, incorporating the teachings of the present
30 invention; and

Fig. 8 is a perspective view of an alternative embodiment to the arrangement shown in Fig. 7.



Description of the Preferred Embodiments

Reference will now be made in detail to the present preferred embodiments of the invention as illustrated in the accompanying drawings.

5 In accordance with the present invention there is provided a clamp comprising: a first longitudinally extending clamp means for engaging a workpiece; a second longitudinally extending clamp means extendable parallel to the longitudinal direction of the first clamp means
10 for clamping a workpiece between the second clamp means and the first clamp means as the second clamp means is longitudinally extended in a direction parallel to the longitudinal direction of the first clamp means. It is preferable that the second clamp means is extendable
15 relative to the first clamp means and that a base means is included for supporting and cantilevering the first and second clamp means.

As shown and embodied in Fig. 1, there is provided a clamp 30. The first longitudinally extending
20 clamp means is a first rigid longitudinally extending clamp bar 32 which is a slender member. The second longitudinally extending clamp means includes a second longitudinally extending clamp bar 34 which is a slender member that extends generally parallel to the
25 longitudinal extent of the first clamp bar 32. The base means includes a first rodless cylinder 36 and a second rodless cylinder 38. Both rodless cylinders 36 and 38 are connected to a rigid frame 40 which supports and fixes both rodless cylinders 36 and 38 relative to the ground
30 during operation.

Rodless cylinders, in and of themselves, are known, commercially available devices which may be obtained from manufacturers such as Tol-O-Matic or Origa. Although rodless cylinders are currently preferable, the
35 use of traditional piston and cylinder arrangements, as well as other motive systems, are within the scope of the

invention. Rodless cylinders 36 and 38 include respective outer housings 42 and 44 which are secured to frame 40, pistons 46 and 48 which are selectively powered and movably positioned along the longitudinal length of 5 outer housings 42 and 44.

Piston 46 of first rodless cylinder 36 is attached to first clamp bar 32 through an intermediate support 58. Likewise, piston 48 of second rodless cylinder 38 is connected to second clamp bar 34 through 10 an intermediate support 60. In such a manner, the first rodless cylinder 36 is used to support, as well as longitudinally extend and retract first clamp bar 32. Likewise, second rodless cylinder 38 is used to support, as well as longitudinally extend and retract second clamp 15 bar 34 in a direction parallel to the longitudinal extent of the first clamp bar 32. Clamp bars 32 and 34 are cantilevered by rodless cylinders 36 and 38 because they are only attached to rodless cylinders 36 and 38 at one of the respective ends. Clamp bars 32 and 34 are 20 independently extendable relative to each other and are also simultaneously extendable relative to rodless cylinders 36 and 38.

According to the present invention, the first clamp means includes first contact means for contacting 25 the workpiece, and the second clamp means includes second contact means opposed to the first contact means for contacting the workpiece, the second contact means being supported by the remaining portion of the second clamp means and movable relative to the remaining portion to 30 the second clamp means while being fixed relative to the first contact means for clamping the workpiece between the first contact means and the second contact means.

As shown and embodied in Figs. 1 and 2, and 4A-E the first contact means is a contact strip 62 of 35 resilient material. The remaining portion of the first clamp means is the remaining portion 64 of the first

clamp bar 32, namely, a metal bar with a longitudinally running groove. Contact strip 62 is affixed in the longitudinally running groove of remaining portion 64 of first clamp bar 32. Therefore, it is seen that the remaining portion of the first clamp means is the portion of the first clamp means other than the first contact means.

As shown and alternatively embodied in Figs. 3 and 5A-C the first contact means is a belt 66a which passes around pulleys 68a at the ends of first clamp bar 32a. The remaining portion of the first clamp means is the remaining portion 64a of the first clamp bar 32a, namely, a metal bar with a longitudinally running slot. Pulleys 68a and belt 66a are positioned in the longitudinally running slot of remaining portion 64a of first clamp bar 32a so that belt 66a is longitudinally movable relative to the remaining portion 64a of first clamp bar 32a. Therefore, it is seen that the remaining portion of the first clamp means is the portion of the first clamp means other than the first contact means.

In the embodiment of Figs. 1, 2 and 4A-E, the second contact means includes an endless belt 70 which passes around pulleys 72. The remaining portion of the second clamp means is the remaining portion 74 of second clamp bar 34, namely, a metal bar with a longitudinally running slot. Pulleys 72 and belt 70 are positioned in and supported by the remaining portion 74a of a second clamp bar 34a. Therefore, it is seen that the remaining portion of second clamp means is the portion of the second clamp means other than the second contact means. Belt 70 is movable along the longitudinal length of second clamp bar 34 relative to the remaining portion 74 of the second clamp bar 34 while being fixed relative to contact strip 62.

In the embodiment of Figs. 3 and 5A-C, the second contact means includes an endless belt 70a which passes around pulleys 72a. The remaining portion of the second clamp means is the remaining portion 74a of the second clamp bar 34a, namely, a metal bar with a longitudinally running slot. Pulleys 72a and belt 70a are positioned in and supported by the remaining portion 74a of second clamp bar 34a. Therefore, it is seen that the remaining portion of second clamp means is the portion of the second clamp means other than the second contact means. Belt 70a is movable along the longitudinal length of second clamp bar 34a relative to the remaining portion 74a of the second clamp bar 34a while being fixed relative to belt 66a.

In the embodiment of Figs. 1, 2 and 4A-E, and shown in Fig. 4A-E, a portion 75 of belt 70 is attached to the first clamp bar 32 to allow the opposing portion of belt 70 to be fixed relative to contact strip 62 at all times. In this arrangement, the opposing portion of belt 70 will move relative to remaining portion 74 of second clamp bar 34 when there is relative movement between the remaining portions 64 and 74 of clamp bars 32 and 34.

In the embodiment shown in Figs. 3 and 5, the opposing portions of belts 66a and 70a have no translational movement relative to each other. Belts 66a and 70a are preferably anchored relative to the ground by an anchor 99 which securely engages both belts at that point so that they undergo no translational movement relative to the ground when the remaining portions 64a and 74a of clamp bars 32 and 34a are moved longitudinally. Alternatively, belts 66a and 70a may be free from the ground and movable only when engaging a workpiece. However, if the clamp is actuated in its intended manner to engage a workpiece which is fixed

relative to the ground, it is preferable to anchor belts 66a and 70a to the ground to avoid damaging a fragile workpiece.

As shown in the sequential operations depicted 5 in Figs. 4A-E and 5A-C, the first and second clamp bars 32 and 34 are advanced to engage a workpiece and clamp the workpiece between the opposing contact surfaces of the first and second clamp bars 32 and 34. As such, the first and second contact means sequentially and 10 continuously clamp the workpiece across a section of the workpiece.

According to the present invention, there is provided means for orienting and forcing the first and second clamp means together. It is preferable that the 15 orienting and forcing means is a C-shaped bracket with a portion of the bracket located proximate to the cantilevered end of the second clamp means. It is also preferable that the bracket is secured to the second clamp means and slidable relative to the first clamp 20 means.

As shown and embodied in Figs. 1 and 3, the means for orienting and forcing the first and second clamp means together includes a C-shaped bracket 76 which extends along most of the length of second clamp bar 34. 25 A portion of bracket 76 is located near the cantilevered end of second clamp bar 34. Bracket 76 is secured to remaining portion 74 of second clamp bar 34, and is slidable relative to first clamp bar 32. A low friction strip 78 is positioned between bracket 76 and first clamp 30 bar 32 to facilitate the sliding action between bracket 76 and first clamp bar 32.

In accordance with the present invention, there is provided cutting means mounted near the cantilevered end of the second clamp means for cutting the workpiece 35 while clamping the workpiece.

As shown and embodied in Figs. 1 and 6, the cutting means includes a razor knife blade 80 which is mounted on and moves with bracket 76 and second clamp bar 34. Blade 80 has a sharp edge 82 for cutting the workpiece as second clamp bar 34 is extended while clamping the workpiece in between first clamp bar 32 and second clamp bar 34. As shown and embodied in Fig. 7, the workpiece is a web 82 which is dispensed from a roll 84 to wrap a load 86 which is conveyed into position on a conveyor 88. As shown in Fig. 7 after the cutting step, web 82 remains clamped in first and second clamp bars 32 and 34 after being cut.

In accordance with the present invention, there is provided wipe down means mounted near the cantilevered end of the second clamp means for wiping down the workpiece while clamping the workpiece. As shown and embodied in Figs. 1, 6 and 7, there is provided a wipedown brush 90 for wiping down the trailing edge portion 92 of the web which has been wrapped around load 86. As a result, trailing edge 92 of the web is smoothed down into an adhered state to a layer of web 94 which has already been wrapped on load 86. The wipedown with brush 90 occurs during the extension of second clamp bar 34 so the clamping, cutting, and wipedown all occurs in one smooth operation.

In accordance with the present invention, there is provided apparatus for clamping a web and wrapping a load with the web comprising: means for dispensing the web; means for rotating the load relative to the dispenser means to wrap the web on the load; and means for clamping the web including a first longitudinally extending clamp means for engaging the web, a second longitudinally extending clamp means extendable in a direction generally parallel to the longitudinal direction of the first clamp means for clamping the web

between the second clamp means as the second clamp means is longitudinally extended in a direction parallel to the longitudinal direction of the first clamp means.

As shown and embodied in Fig. 7, there is provided a stretch wrapping apparatus 96 for clamping a web and wrapping a load with the web. The means for dispensing the web includes a web dispenser housing 98 for a rotatably supporting web roll 84 and prestretch rollers 100 and 102. The means for rotating the load relative to the dispenser means to wrap the web on the load includes ring 104 which is rotatably mounted on a frame (not shown) and rotatably driven by a motor 106 in a clockwise direction. Although the web dispenser 98 may be fixed relative to the ground and the load 86 rotated relative to the ground, it is preferable that the load 86 be fixed relative to the ground and that web dispenser 98 move relative to the ground by revolving around the load.

The first and second clamp means may be positioned so that their longitudinal direction is oblique to the plane defined by the path of the revolving dispenser during wrapping. This may be preferable where economy of space is required. As shown in Fig. 8, the longitudinal direction of first and second clamp bars 32 and 34 is oblique to the plane defined by the path of the revolving dispenser which is shown by ring 104 and which as shown generally extends along a horizontal line projected out of the paper.

According to the present invention there is provided means for conveying the load along a direction perpendicular to the plane defined by the path of the revolving dispenser during wrapping. As shown and embodied in Figs. 7 and 8, the means for conveying the load is a conveyor belt 88 which moves in the direction of the arrow shown in Fig. 8 which is perpendicular to the plane defined by the path of the dispenser along ring 104.

The first and second clamp means may be positioned so that their longitudinal direction is oblique to the conveying direction. As shown and embodied in Fig. 8, first and second clamp bars 32 and 34 are positioned oblique to the conveying direction of conveyor belt 88. This allows for a greater economy of space in the conveying direction.

In accordance with the present invention there is provided a method for clamping a web and wrapping a load with a web comprising: positioning a load in a position to be wrapped; rotating the load relative to a web dispenser to wrap the web on the load; extending a first longitudinally extending clamp element along its longitudinal direction into the wrapping path of the web; passing the web over the first clamp element; and subsequent to extending the first clamp element, extending a second longitudinally extending clamp element along its longitudinal direction in a direction parallel to the first clamp element to clamp the web between the first and second clamp elements as the second clamp element is longitudinally extended in a direction parallel to the longitudinal direction of the first clamp element. In accordance with an embodiment of the present invention, it is preferable that the step of extending the first clamp element occurs prior to the step of extending the second clamp element, and the step of passing the web over the first clamp element occurs subsequent to extending the first clamp element and prior to extending the second clamp element.

As shown and embodied in Figs. 7, 8 and 4A-E, the load is placed in a position to be wrapped by conveying load 86 on conveyor belt 88 to a position inside and aligned with ring 104. The step of rotating the load relative to a web dispenser to wrap the web on the load is performed by using ring 104 to revolve web dispenser 98 in a circle around load 86. At the

beginning of each wrapping operation, the leading edge of web 82 is positioned between clamp bars 32 and 34. It is also possible to start the wrapping cycle by otherwise securing the leading edge of web 82 to the load or the conveyor 88, such as when initiating a continuous operation of wrapping a series of loads.

The step of extending a first longitudinally extending clamp element along its longitudinal direction into the wrapping path of the web is shown as the operation of moving first clamp bar 32 longitudinally between the positions shown in Figs. 4A and 4B. This occurs after the load 86 and conveyor 88 have been wrapped with at least one layer of web 94 shown in Fig. 7.

The step of passing the web over the first clamp element is shown in Fig. 8 by passing the web over first clamp bar 32.

The step of subsequently extending a second longitudinally extending clamp element is shown as the operation of extending second clamp bar 34 from the position shown in Fig. 4B to the position shown in 4C. Bracket 76, being attached to second clamp bar 34, moves with and slides relative to first clamp bar 32. This sequentially and continuously clamps the web across the section of the web between first and second clamp bars 32 and 34.

In accordance with the present invention the step of extending the second clamping element includes cutting the web while clamping the web. It is also preferable that the cutting step includes sequentially and continuously clamping the web ahead of the point at which the web is being cut and that the clamping of the web occurs both in front of and behind the point at which the web is being cut. As shown in Fig. 6, the positioning of razor knife blade 80 on second clamp bar 34 and bracket 76 allows the web to be cut while second

clamp bar 34 and bracket 76 are being extended. Since razor knife blade 80 is positioned near but behind the forward edge of second clamp bar 34, the clamping of the web occurs both in front of and behind the point at which the web is being cut. As a result, the web is not pulled out of position during the cutting step and is held in the position shown in Fig. 7 after the cutting step so that a new wrapping operation can proceed.

In accordance with the present invention, it is preferable that the step of extending the second clamp element includes wiping down the trailing end of the web while clamping the web. As shown and embodied in Fig. 7, the trailing end 92 of the web is wiped down with brush 90 while extending second clamp bar 34 to clamp the web.

The step of extending the first and second clamp elements may include extending those elements along the direction which is oblique to the plane defined by the path of the revolving dispenser during wrapping and oblique to the direction in which the load is conveyed. As shown and embodied in Fig. 8, first and second clamping bars 32 and 34 are extended in a direction which is oblique to the path of the dispenser 98 around ring 104 and the direction in which the load is conveyed along conveyor 88.

In accordance with the present invention, it is preferable that in a continuous operation, the wrapped load is removed from the position to be wrapped while continuing to keep the web clamped between the extended first and second clamp elements. As shown and embodied in Figs. 7, wrapped load 86 is conveyed from the wrapping position inside ring 104. A new load to be wrapped is conveyed on conveyor 88 into a position identical to load 86. Meanwhile, web 82 continues to be clamped between first and second clamp bars 32 and 34 which are extended in the position shown in Fig. 4C.

The step of rotating the new load relative to a web dispenser to wrap the web on the new load is accomplished by revolving film web dispenser 98 around the new load through the use of ring 104.

5 The second longitudinally extending clamp element is retracted along its longitudinal extent after at least one wrap of web 82 around the load so that web 82 holds against itself and no longer needs to be clamped during wrapping of the new load. This retraction step is
10 shown and embodied as the operation of retracting second clamp bar 34 from the positions shown in Fig. 4C to that shown in Fig. 4D.

 The step of retracting the first longitudinally extending clamp element along its longitudinal extent is
15 shown as the operation of retracting first clamp bar 32 from the position shown in Fig. 4D to that shown in Fig. 4E. The load can continue to be wrapped while the first and second clamp elements are retracted as shown and embodied in the position of first and second clamp bars
20 32 and 34 in the retracted position of Fig. 4E. The whole cycle embodied in the step shown in Figs. 4A-4E may continue to be executed for subsequent new loads, making the operation a continuous one.

 In the preferred embodiment of the method
25 described above, the step of retracting the second clamp element occurs prior to the step of retracting the first clamp element and is shown and embodied in Figs. 4A-4E as independently moving first and second clamp bars 32 and 34 as described.

30 In accordance with the second preferred method, the steps of extending and retracting the first clamp element and the second clamp element preferably occur simultaneously. As shown and embodied in Figs. 5A-5C, first and second clamp bars 32a and 34a include belts 66a
35 and 70a and first and second clamp bars 32a and 34a

extends simultaneously in the operation occurring from Figs. 5A to 5B, and retract simultaneously in the operation from Figs. 5B to 5C.

Additional advantages and modifications will readily occur to those skilled in the art. The invention in its broader aspects is, therefore, not limited to the specific details, representative apparatus and illustrative examples shown and described. Accordingly, departures may be made from such details without departing from the spirit or scope of the general inventive concept as defined by the appended claims and their equivalents.

11
12
13
14
15
16
17
18
19
20
21
22
23
24
25
26
27
28
29
30
31
32
33
34
35
36
37
38
39
40
41
42
43
44
45
46
47
48
49
50
51
52
53
54
55
56
57
58
59
60
61
62
63
64
65
66
67
68
69
70
71
72
73
74
75
76
77
78
79
80
81
82
83
84
85
86
87
88
89
90
91
92
93
94
95
96
97
98
99
100

101
102
103
104
105
106
107
108
109
110
111
112
113
114
115
116
117
118
119
120
121
122
123
124
125
126
127
128
129
130
131
132
133
134
135
136
137
138
139
140
141
142
143
144
145
146
147
148
149
150
151
152
153
154
155
156
157
158
159
160
161
162
163
164
165
166
167
168
169
170
171
172
173
174
175
176
177
178
179
180
181
182
183
184
185
186
187
188
189
190
191
192
193
194
195
196
197
198
199
200

201
202
203
204
205
206
207
208
209
210
211
212
213
214
215
216
217
218
219
220
221
222
223
224
225
226
227
228
229
230
231
232
233
234
235
236
237
238
239
240
241
242
243
244
245
246
247
248
249
250
251
252
253
254
255
256
257
258
259
260
261
262
263
264
265
266
267
268
269
270
271
272
273
274
275
276
277
278
279
280
281
282
283
284
285
286
287
288
289
290
291
292
293
294
295
296
297
298
299
300

301
302
303
304
305
306
307
308
309
310
311
312
313
314
315
316
317
318
319
320
321
322
323
324
325
326
327
328
329
330
331
332
333
334
335
336
337
338
339
340
341
342
343
344
345
346
347
348
349
350
351
352
353
354
355
356
357
358
359
360
361
362
363
364
365
366
367
368
369
370
371
372
373
374
375
376
377
378
379
380
381
382
383
384
385
386
387
388
389
390
391
392
393
394
395
396
397
398
399
400

THE CLAIMS DEFINING THE INVENTION ARE AS FOLLOWS:

1. A clamp comprising:
a first longitudinally extending clamp means including first contact means for contacting a workpiece;
a second longitudinally extending clamp means extendable in a direction parallel to the longitudinal direction of the first clamp means, the second clamp means including second contact means opposed to the first contact means for contacting the workpiece, the second contact means being supported by a remaining portion of the second clamp means and movable in the longitudinal direction relative to the remaining portion of the second clamp means while being fixed relative to the first contact means for clamping a workpiece between the second contact means and the first contact means as the remaining portion of the second clamp means is longitudinally extended in a direction parallel to the longitudinal direction of the first clamp means.
2. The clamp of Claim 1 wherein the remaining portion of the second clamp means is extendable relative to the first clamp means for clamping the workpiece between the second clamp means and first clamp means when the remaining portion of the second clamp means is extended relative to the first clamp means.
3. The clamp of Claim 1 including a base means for supporting and cantilevering the first and second clamp means.
4. The clamp of Claim 3 wherein the first clamp means has a remaining portion for supporting the first contact means and the remaining portions of the first and second clamp means are simultaneously extendable relative to the base means for clamping the workpiece between the second contact means and the first contact means when the remaining portions of the first and second clamp means are simultaneously extended in the same direction.



5. The clamp of Claim 1 wherein the first and second contact means sequentially clamp the workpiece across a section of the workpiece.
6. The clamp of Claim 1 wherein the first and second contact means continuously clamp the workpiece across a section of the workpiece.
7. The clamp of Claim 1 wherein the first and second contact means sequentially and continuously clamp the workpiece across a section of the workpiece.
8. The clamp of Claim 1 wherein the first and second clamp means are slender members.
9. The clamp of Claim 3 including means for orienting and forcing the first and second clamp means together.
10. The clamp of Claim 8 wherein a portion of the orienting and forcing means is located proximate to the cantilevered end of the second clamp means.
11. The clamp of Claim 9 wherein the orienting and forcing means is a bracket.
12. The clamp of Claim 11 wherein the bracket is secured to the remaining portion of the second clamp means and slidable relative to the first clamp means.
13. The clamp of Claim 12 wherein the bracket is C-shaped.
14. The clamp of Claim 1 wherein the first contact means includes a resilient material.
15. The clamp of Claim 14 wherein the first contact means is fixed relative to the remaining portion of the first clamp means.
16. The clamp of Claim 1 wherein the second contact means is a belt.
17. The clamp of Claim 15 wherein both the first contact means and the second contact means are belts.
18. The clamp of Claim 17 wherein each of the belts is movable relative to the remaining portion of its respective clamp means.



19. The clamp of Claim 16 wherein the second contact means belt is secured to the first clamp means.

20. The clamp of Claim 16 wherein the second contact means belt doubles back on journals at each end of the second clamp means.

21. The clamp of Claim 3 including cutting means mounted proximate to the cantilevered end of the second clamp means for cutting the workpiece while clamping the workpiece.

22. The clamp of Claim 1 including cutting means mounted proximate to the cantilevered end of the second clamp means for cutting the workpiece while clamping the workpiece.

23. The clamp of Claim 3 including wipe down means mounted near the cantilevered end of the second clamp means for wiping down the workpiece while clamping the workpiece.

24. The clamp of Claim 21 including wipe down means mounted near the cantilevered end of the second clamp means for wiping down the workpiece while clamping the workpiece.

25. Apparatus for clamping a web and wrapping a load with the web comprising:

means for dispensing the web;

means for rotating the load relative to the dispenser means to wrap the web on the load; and

means for clamping the web including a first longitudinally extending clamp means having first contact means for contacting the web, a second longitudinally extending clamp means extendable in a direction generally parallel to the longitudinal direction of the first clamp means, the second clamp means including second contact means opposed to the first contact means for contacting the workpiece, the second contact means being supported by a remaining portion of the second clamp means and movable in the longitudinal direction relative to the



remaining portion of the second clamp means while being fixed relative to the first contact means for clamping the web between the second contact means and the first contact means as the remaining portion of the second clamp means is longitudinally extended in a direction parallel to the longitudinal direction of the first clamp means.

26. The apparatus of Claim 25 wherein the means for rotating the load relative to the dispenser means includes means for revolving the dispenser means around the load.

27. The apparatus of Claim 26 wherein the first and second clamp means are positioned so that their longitudinal direction is oblique to the plane defined by the path of the revolving dispenser during wrapping.

28. The apparatus of Claim 26 including means for conveying the load along a direction perpendicular to the plane defined by the path of the revolving dispenser during wrapping.

29. The apparatus of Claim 28 wherein the longitudinal extent of the first and second clamp means is positioned oblique to the conveying direction.

30. The apparatus of Claim 25 including cutting means mounted near the cantilevered end of the second clamp means for cutting the workpiece while clamping the workpiece.

31. The apparatus of Claim 25 including wipe down means mounted near the cantilevered end of the second clamp means for wiping down the workpiece while clamping the workpiece.

32. A method for clamping a web and wrapping a load with a web comprising:

- positioning a load in a position to be wrapped;
- rotating the load relative to a web dispenser to wrap the web on the load;



extending a first longitudinally extending clamp element along its longitudinal direction into the wrapping path of the web;

passing the web over the first clamp element and contacting the web with a contact portion of the first clamp element; and

extending a second longitudinally extending clamp element along its longitudinal direction in a direction parallel to the first clamp element and contacting the web with a contact portion of the second clamp element while moving the contact portion of the second clamp element in the longitudinal direction relative to a remaining portion of the second clamp element but maintaining the contact portion of the second clamp element fixed relative to contact portion of the first clamp element to clamp the web between the contact portions of the first and second clamp elements as the remaining portion of the second clamp element is longitudinally extended in a direction parallel to the longitudinal direction of the first clamp element.

33. The method of Claim 32 wherein the step of extending the first clamp element occurs prior to the step of extending the second clamp element, and the step of passing the web over the first clamp element occurs subsequent to extending the first clamp element and prior to extending the second claim element.

34. The method of Claim 32 wherein the step of extending the first clamp element and the step of extending the second clamp element occur simultaneously.

35. The method of Claim 32 including removing the wrapped load from the position to be wrapped while continuing to keep the web clamped between the extended first and second clamp elements; positioning a new load in the position to be wrapped;



rotating the new load relative to a web dispenser to wrap the web on the new load;

after at least one wrap, retracting the second longitudinally extending clamp element along its longitudinal direction,

retracting the first longitudinally extending clamp element along its longitudinal direction; and

continuing to wrap the web on load while the first and second clamp elements are retracted.

36. The method of Claim 35 wherein the step of retracting the second clamp element occurs prior to the step of retracting the first clamp element.

37. The method of Claim 35 wherein the step of retracting the second clamp element and the step of retracting the first clamp element occur simultaneously.

38. The method of Claim 32 wherein the step of extending the second clamp element includes sequentially clamping the web across a section of the web.

39. The method of Claim 32 wherein the step of extending the second clamp element includes continuously clamping the web across a section of the web.

40. The method of Claim 32 wherein the step of extending the second clamp element includes sequentially and continuously clamping the web across a section of the web.

41. The method of Claim 32 wherein the step of extending the second clamping element includes cutting the web while clamping the web.

42. The method of Claim 41 wherein the cutting step includes sequentially and continuously clamping the web ahead of the point at which the web is being cut.

43. The method of Claim 41 wherein the clamping of the web occurs both in front of and behind the point of which the web is being cut.



44. The method of Claim 32 wherein the step of extending the second clamp element includes wiping down the trailing end of the web while clamping the web.

45. The method of Claim 41 wherein the step of extending the second clamp element includes wiping down the trailing end of the web while clamping the web.

46. The method of Claim 32 including removing the wrapped load from the wrapping position, placing a new load in the wrapping position, wrapping the web around the new load, and retracting the second clamp element from the path of the web.

47. The method of Claim 32 wherein the rotating step includes revolving the web dispenser around the load.

48. The method of Claim 47 wherein the step of extending the first and second clamp elements includes extending those elements along a direction which is oblique to the plane defined by the path of the revolving dispenser during wrapping.

49. The method of Claim 47 wherein the step of positioning and removing the load includes conveying the load in a direction perpendicular to the plane defined by the path of the revolving dispenser during wrapping.

50. The method of Claim 49 wherein the step of extending the first and second clamp elements includes extending those elements along a direction which is oblique to the direction in which the load is conveyed.

DATED THIS 2ND DAY OF NOVEMBER, 1989

LANTECH, INC.

By Its Patent Attorneys:

GRIFFITH HACK & CO.

Fellows Institute of Patent
Attorneys of Australia.



10322/88

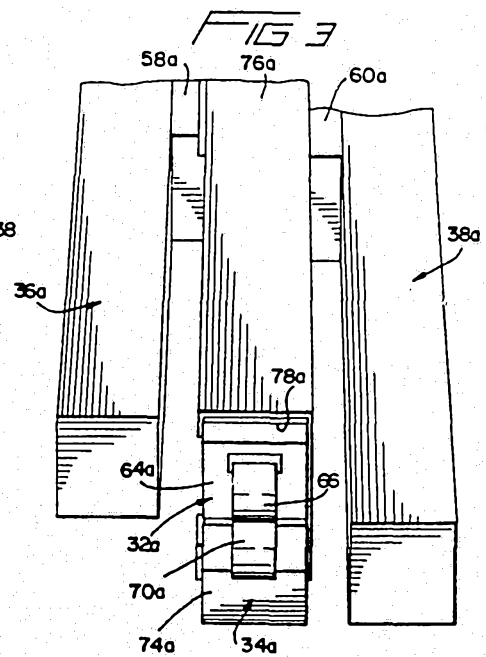
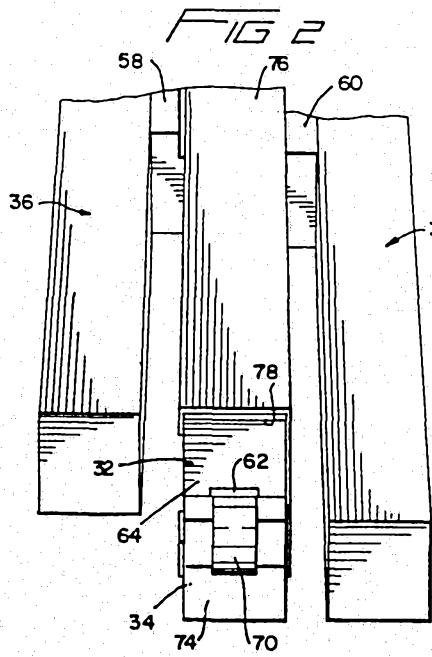
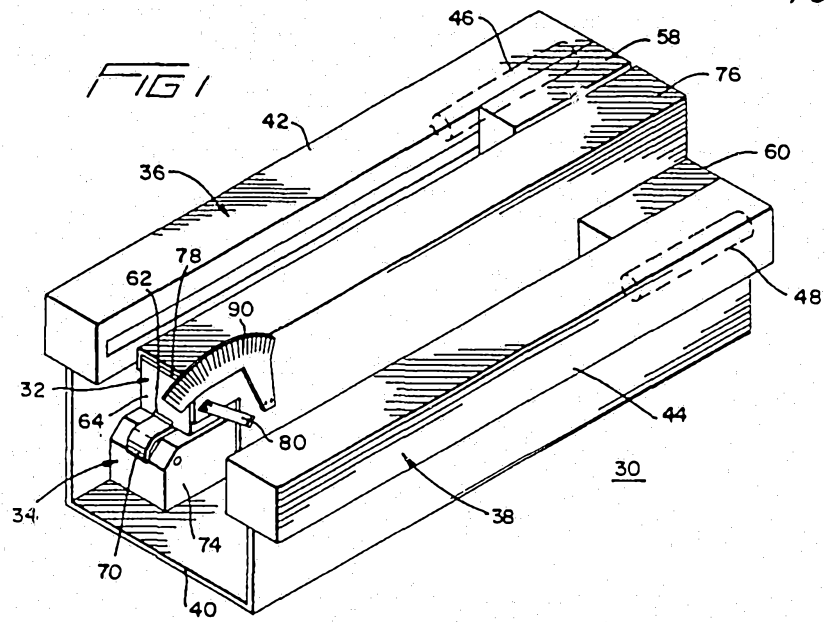

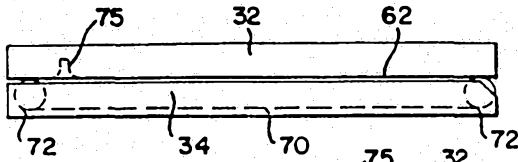

FIG 4A

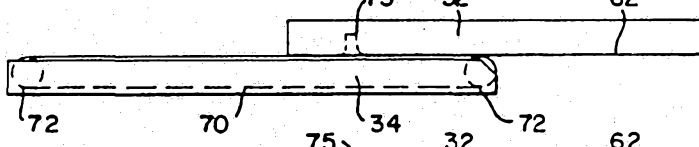

FIG 4B

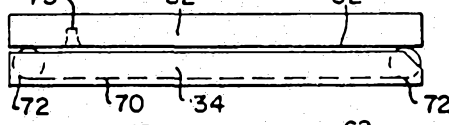

FIG 4C

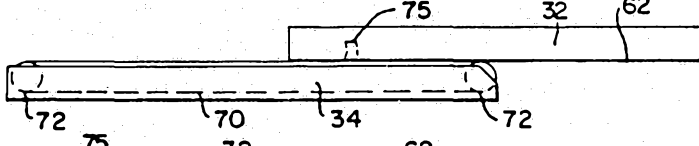

FIG 4D

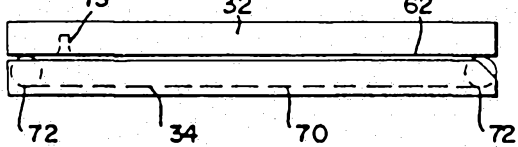

FIG 4E

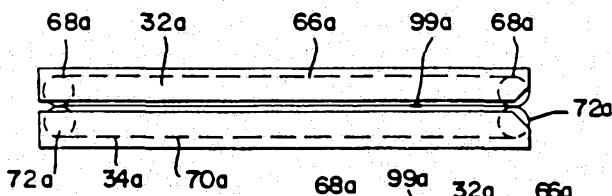

FIG 5A

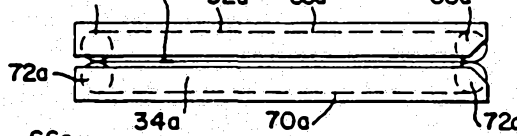

FIG 5B

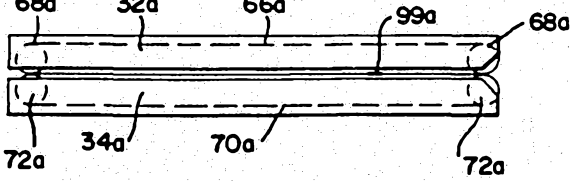

FIG 5C

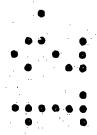
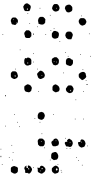
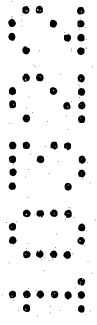

FIG 6

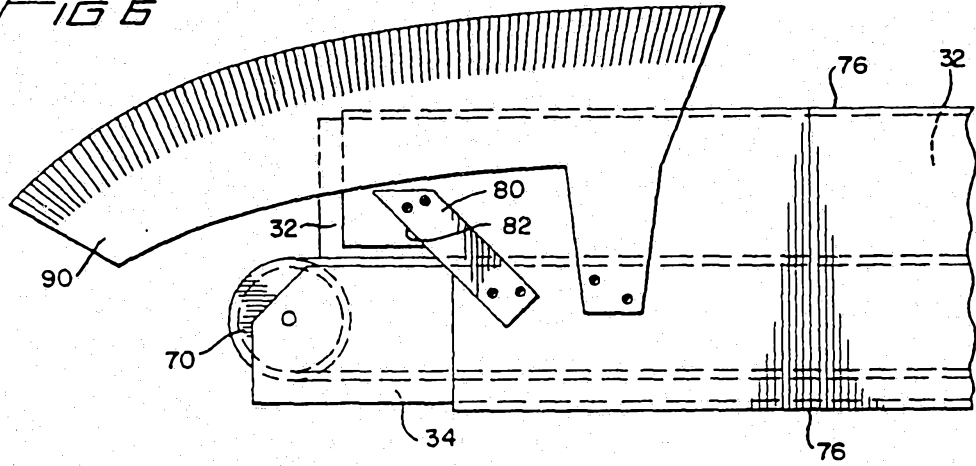
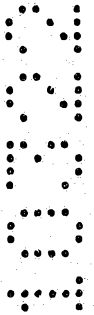
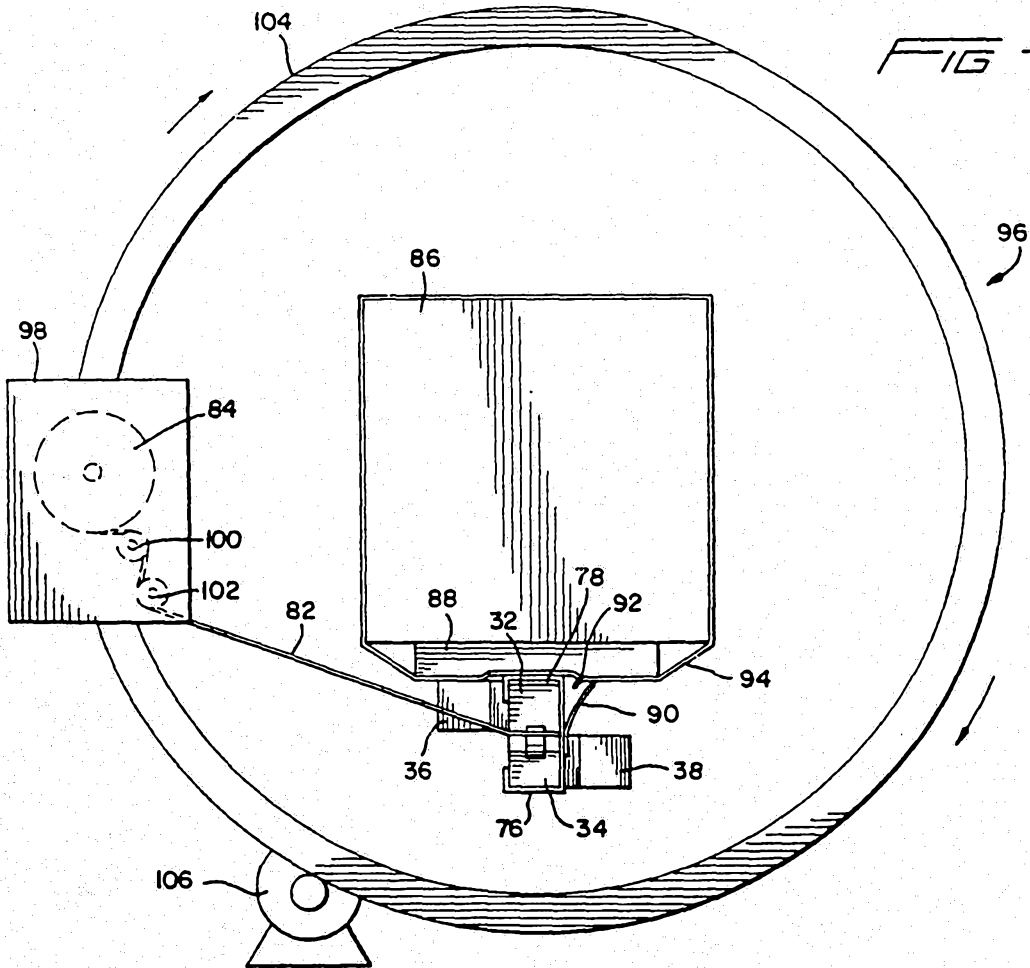

FIG 7



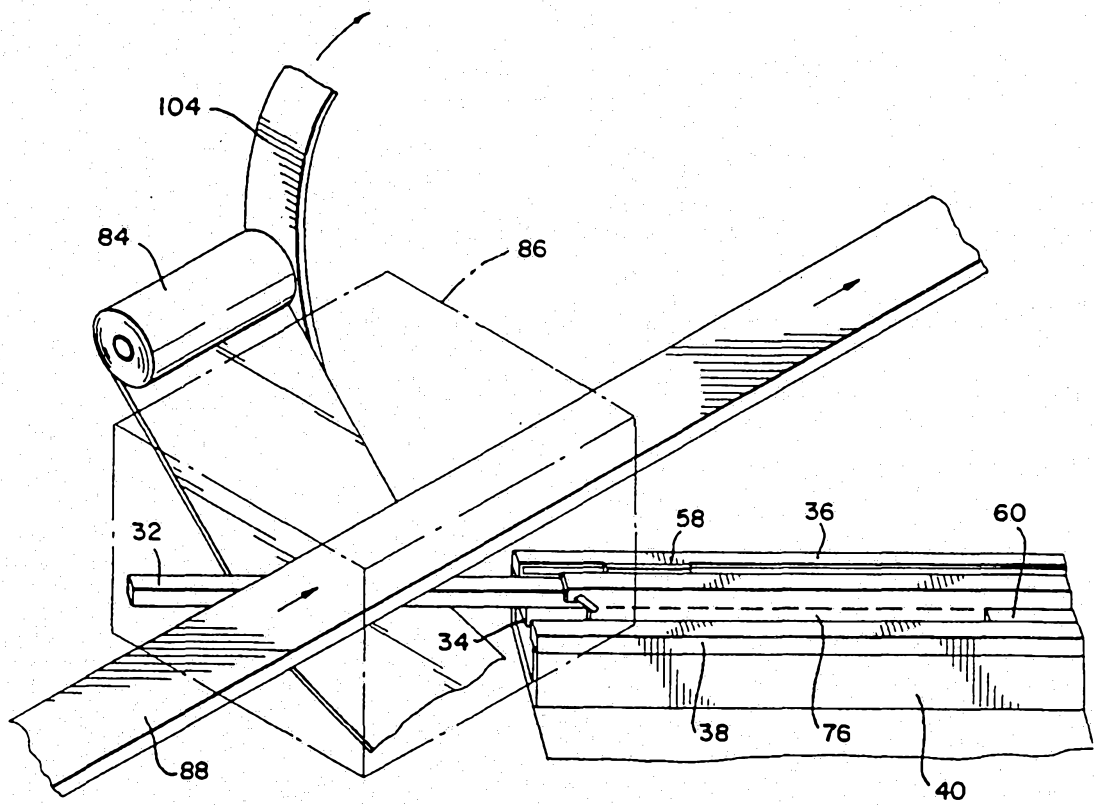

FIG 8