

(19) World Intellectual Property Organization  
International Bureau



(43) International Publication Date  
25 January 2007 (25.01.2007)

PCT

(10) International Publication Number  
**WO 2007/012025 A3**

- (51) International Patent Classification:  
A61F 2/30 (2006.01)
- (21) International Application Number:  
PCT/US2006/028100
- (22) International Filing Date: 19 July 2006 (19.07.2006)
- (25) Filing Language: English
- (26) Publication Language: English
- (30) Priority Data:  
60/700,887 19 July 2005 (19.07.2005) US
- (71) Applicant and
- (72) Inventor: RITLAND, Stephen [US/US]; 1150 N. San Francisco Street, Flagstaff, AZ 86001 (US).
- (74) Agents: IGNAT, Brian, J. et al.; SHERIDAN ROSS P.C., 1560 Broadway, Suite 1200, Denver, CO 80202-5141 (US).
- (81) Designated States (unless otherwise indicated, for every kind of national protection available): AE, AG, AL, AM, AT, AU, AZ, BA, BB, BG, BR, BW, BY, BZ, CA, CH, CN, CO, CR, CU, CZ, DE, DK, DM, DZ, EC, EE, EG, ES, FI,

GB, GD, GE, GH, GM, HN, HR, HU, ID, IL, IN, IS, JP, KE, KG, KM, KN, KP, KR, KZ, LA, LC, LK, LR, LS, LT, LU, LV, LY, MA, MD, MG, MK, MN, MW, MX, MZ, NA, NG, NI, NO, NZ, OM, PG, PH, PL, PT, RO, RS, RU, SC, SD, SE, SG, SK, SL, SM, SY, TJ, TM, TN, TR, TT, TZ, UA, UG, US, UZ, VC, VN, ZA, ZM, ZW.

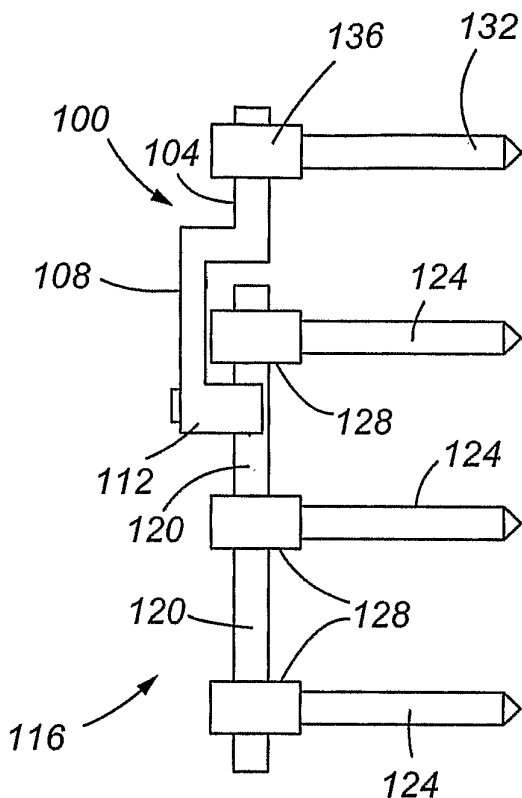
(84) Designated States (unless otherwise indicated, for every kind of regional protection available): ARIPO (BW, GH, GM, KE, LS, MW, MZ, NA, SD, SL, SZ, TZ, UG, ZM, ZW), Eurasian (AM, AZ, BY, KG, KZ, MD, RU, TJ, TM), European (AT, BE, BG, CH, CY, CZ, DE, DK, EE, ES, FI, FR, GB, GR, HU, IE, IS, IT, LT, LU, LV, MC, NL, PL, PT, RO, SE, SI, SK, TR), OAPI (BF, BJ, CF, CG, CI, CM, GA, GN, GQ, GW, ML, MR, NE, SN, TD, TG).

**Published:**  
— with international search report  
— before the expiration of the time limit for amending the claims and to be republished in the event of receipt of amendments

(88) Date of publication of the international search report:  
1 November 2007

[Continued on next page]

(54) Title: ROD EXTENSION FOR EXTENDING FUSION CONSTRUCT



(57) Abstract: In accordance with embodiments of the present invention, a rod extension for extending a fusion construct is provided. The rod extension allows a surgeon to connect a stabilization rod implant to at least a portion of a patient's spine, and also to connect the stabilization rod implant to an existing implant that has been previously installed in the patient. The existing fusion implant typically includes at least one existing pedicle screw, at least one existing rod, and at least one existing connector interconnecting the existing pedicle screw to the existing rod. The extension implant comprises a rod, an offset beam connected to the rod, and a clamp interconnected to the offset beam, wherein the clamp can be secured to the existing rod, thereby extending the fusion construct. A method of use is also provided.

WO 2007/012025 A3



---

*For two-letter codes and other abbreviations, refer to the "Guidance Notes on Codes and Abbreviations" appearing at the beginning of each regular issue of the PCT Gazette.*

## ROD EXTENSION FOR EXTENDING FUSION CONSTRUCT

## FIELD OF THE INVENTION

The present invention pertains to spinal implants, and more specifically, to a device for extending a pre-existing implant having a rod component.

## BACKGROUND OF THE INVENTION

At times, spinal surgeons are faced with the problem of having to add additional length to a fusion rod that spans one or more intervertebral disks. For example, a patient may have had a previous surgery whereby they received an implant spanning a single lumbar disk, wherein the implant serves to structurally fuse the vertebra on either side of the disk using pedicle screws that are connected to a rigid rod that bridges the disk.

If the patient then develops a problem with an adjacent disk, the surgeon is faced with having to somehow bridge the adjacent disk; however, a location to anchor the first end of the new fusion implant is already taken up by the existing implant. Accordingly, surgeons typically open the region of the existing implant and install a new implant that spans the length of the first implant, as well as the additional disk that has become problematic. This existing solution causes the disruption of the area of the first implant, and therefore, results in additional tissue damage and required healing time, added surgical time, and added corresponding treatment costs.

Accordingly, it would be advantageous to be able to attach the new implant to the existing implant without removing the first implant or unnecessarily disrupting or causing tissue damage to the area of the existing implant.

## SUMMARY OF THE INVENTION

In accordance with embodiments of the present invention, a spinal fusion extension implant is provided for interconnecting to an existing fusion implant in a spine of a patient, the existing fusion implant having at least one existing pedicle screw, at least one existing rod, and at least one existing connector interconnecting the existing pedicle screw to the existing rod, the extension implant comprising a rod, an offset beam connected to the rod; and a clamp connected to the offset beam, wherein the clamp is adapted to be secured to the existing rod.

In accordance with embodiments of the present invention, an extension implant is provided, wherein the clamp comprises a receptacle for receiving at least a portion of the existing rod and the receptacle comprises opposing arms that extend around at least an equator of the existing rod.

In accordance with embodiments of the present invention, an extension implant is

# ROD EXTENSION FOR EXTENDING FUSION CONSTRUCT

## FIELD OF THE INVENTION

The present invention pertains to spinal implants, and more specifically, to a device for extending a pre-existing implant having a rod component.

## BACKGROUND OF THE INVENTION

At times, spinal surgeons are faced with the problem of having to add additional length to a fusion rod that spans one or more intervertebral disks. For example, a patient may have had a previous surgery whereby they received an implant spanning a single lumbar disk, wherein the implant serves to structurally fuse the vertebra on either side of the disk using pedicle screws that are connected to a rigid rod that bridges the disk.

If the patient then develops a problem with an adjacent disk, the surgeon is faced with having to somehow bridge the adjacent disk; however, a location to anchor the first end of the new fusion implant is already taken up by the existing implant. Accordingly, surgeons typically open the region of the existing implant and install a new implant that spans the length of the first implant, as well as the additional disk that has become problematic. This existing solution causes the disruption of the area of the first implant, and therefore, results in additional tissue damage and required healing time, added surgical time, and added corresponding treatment costs.

Accordingly, it would be advantageous to be able to attach the new implant to the existing implant without removing the first implant or unnecessarily disrupting or causing tissue damage to the area of the existing implant.

## SUMMARY OF THE INVENTION

In accordance with embodiments of the present invention, a spinal fusion extension implant is provided for interconnecting to an existing fusion implant in a spine of a patient, the existing fusion implant having at least one existing pedicle screw, at least one existing rod, and at least one existing connector interconnecting the existing pedicle screw to the existing rod, the extension implant comprising a rod, an offset beam connected to the rod; and a clamp connected to the offset beam, wherein the clamp is adapted to be secured to the existing rod.

In accordance with embodiments of the present invention, an extension implant is provided, wherein the clamp comprises a receptacle for receiving at least a portion of the existing rod and the receptacle comprises opposing arms that extend around at least an equator of the existing rod.

In accordance with embodiments of the present invention, an extension implant is

provided, wherein the clamp comprises a deformable body having a slot with first and second sides, the deformable body having a first wing on the first slot side and a second wing on the second slot side.

In accordance with embodiments of the present invention an extension implant is provided, further comprising a screw for deforming at least one of the first or second wings away from the other of the first or second wings.

In accordance with embodiments of the present invention, an extension implant is provided, wherein the rod portion and the offset beam are connected by means of a transitional section.

In accordance with embodiments of the present invention a spinal fusion extension implant is provided for interconnecting to an existing fusion implant in a spine of a patient, the existing fusion implant having at least one existing pedicle screw, at least one existing rod, and at least one existing connector interconnecting the existing pedicle screw to the existing rod, the extension implant comprising a means for longitudinally stabilizing at least a portion of the spine, a means for offsetting around at least one of the existing pedicle screw and the existing connector, the means for offsetting connected to the means for longitudinally stabilizing, and a means for clamping connected to the means for offsetting, wherein the means for clamping secures the means for longitudinally stabilizing and the means for offsetting to the existing rod.

In accordance with embodiments of the present invention, a clamp is provided for attaching a first spinal implant member to a second spinal implant member, comprising a deformable body, a receptacle, within the deformable body, for receiving at least a portion of the second spinal implant member, the receptacle comprising opposing arms, wherein the opposing arms extend around at least an equator of the second spinal implant member, a slot, within the deformable body, wherein the slot separates a first and second wing of the deformable body; and a screw for tightening the clamp, wherein the screw operates to separate the first and second wings and wherein the separation results in a deformation of the deformable body, whereby the deformation results in a closing of the receptacle around the at least a portion of the second spinal implant member.

In accordance with embodiments of the present invention, a clamp is provided further comprising a screw hole, within the deformable body, extending through the first wing of the deformable body, the screw hole adapted to receive the screw to facilitate contact with the second wing of the deformable body.

In accordance with embodiments of the present invention, a method for extending a

spinal rod is provided, comprising the steps of installing a pedicle screw into a vertebra adjacent an existing spinal implant, connecting the pedicle screw to a portion of a spinal rod extension, having a clamp operatively associated therewith, the clamp having at least one receptacle adapted to receive a rod and being deformable to secure the rod, inserting into the receptacle a rod portion of the existing implant, and deforming the clamp to secure the rod portion of the existing spinal implant.

#### BRIEF DESCRIPTION OF THE DRAWINGS

Fig. 1a is a side elevation view of an existing implant and of an embodiment of the present invention connected to the implant;

Fig. 1b is a side elevation view of the existing implant and embodiment of the present invention shown in Fig. 1b, shown here attached to a spine;

Fig. 2 is a top plan view of the embodiment of the present invention shown in Fig. 1a;

Fig. 3 is a cross-sectional view of a rod portion of the embodiment of the present invention shown in Fig. 2;

Fig. 4 is a cross-sectional view of an offset beam portion of the embodiment of the present invention shown in Fig. 2;

Fig. 5 is a cross-sectional view of a transitional rod-to-offset beam portion of the embodiment of the present invention shown in Fig. 2; and

Fig. 6 is a cross-sectional view of a clamp portion of the embodiment of the present invention shown in Fig. 2.

Drawings are not necessarily to scale.

#### DETAILED DESCRIPTION

In accordance with embodiments of the present invention, a rod extension for extending a fusion construct is provided. The rod extension allows a surgeon to connect a stabilization rod implant to at least a portion of a patient's spine, and also connect the stabilization rod implant to an existing implant that has been previously installed in the patient. In various embodiments of the present invention a device is provided that may be used to extend an existing fusion rod implant cephalad and caudal.

Referring now to Fig. 1a, rod extension 100 is shown in accordance with embodiments of the present invention. The rod extension 100 provides for a simple, rigid connection to an existing fusion rod. The rod extension 100 generally includes a rod portion 104, an offset beam 108, and a clamp 112. As shown in Fig. 1a, the rod extension 100 is connected to an existing fusion implant 116, wherein the existing fusion implant 116 comprises an existing rod 120,

existing pedicle screws 124, and existing connectors 128 that interconnect the existing rod 120 to the existing pedicle screws 124.

Referring still to Fig. 1a, in accordance with embodiments of the present invention, the rod extension 100 is of sufficient length to allow the device to be anchored to the spine at the end comprising the rod portion 104, while at the other end extending sufficient distance to be connected to an existing implant 116. The end comprising the rod portion 104 may be anchored to the spine using hooks or other means to be attached to the spine. As shown in Fig. 1a, a pedicle screw 132 is shown interconnected to the rod 104 using a connector 136, wherein the pedicle screw 132 may be inserted into the pedicle of a vertebra for anchoring the end comprising the rod portion 104 to the spine. In accordance with embodiments of the present invention, the offset beam 108 comprises a means for stepping over or around the screw head of an existing pedicle screw 124 and existing connector 128, thereby allowing the rod portion 104 of the rod extension 100 to be substantially aligned with the existing rod 120. The offset beam 108, therefore, is of sufficient dimensions to allow the rod extension 100 to have access to the existing rod 120 via clamp 112, while also providing clearance from the screw head of an existing screw 124 and its associated existing connector 128. In accordance with embodiments of the present invention, the offset beam 108 may further comprise a telescoping means or other means for adjusting its longitudinal length and/or its offset or step dimension to accommodate different implant systems and/or to further accommodate actual conditions found within each patient.

Fig. 1a illustrates one possible orientation of existing rod 120, rod portion 104, offset beam 108, and clamp 112. In particular, existing rod 120 and offset beam 108 are shown to be parallel. Additionally, existing rod 120 and rod portion 104 are shown to be collinear. It should be understood, however, that other orientations are within the scope of the invention. For example, existing rod 120 and offset beam 108 may be oriented at an angle or existing rod 120 and rod portion 104 may not be collinear. Differing orientations may be needed to accommodate the unique dimensions of the various spinal structures of individual patients. In addition, the various elements of the rod extension may be oriented to accommodate the natural curvature of the spine. Furthermore, all of the drawings contained herein are for illustration purposes and should not be considered to scale.

Referring now to Fig. 1b, a rod extension 100, in accordance with embodiments of the present invention, is shown attached to a human spine. Fig. 1b shows vertebrae V1, V2, V3, and V4 separated by disks D. The existing spinal fusion implant 116 is shown anchored to

vertebrae V2, V3, and V4. The spinal extension 100 is shown anchored to vertebra V1 and attached to the existing spinal fusion implant 116 by means of connector 112.

Referring to Fig. 2, a top plan view of the rod extension 100 is shown. The rod extension 100 is shown with a rod portion 104 at a first end of the extension 100, and the offset beam 108 with the clamp portion 112 at the other end of the rod extension 100. Fig. 3 shows a cross-sectional view of the rod portion 104. The rod portion 104 is shown to have a circular cross-section, although other shapes are within the scope of the present invention. Fig. 4 illustrates that the offset beam 108 may comprise a rectangular cross section, wherein such cross section provides for a low profile configuration. However, the cross section of the offset beam 108 may take on a circular shape or other desired shape to step over or around the existing screw head and associated connector. Fig. 5 shows a cross section of the transition section 140 between the rod portion 104 and the offset beam 108.

Referring now to Fig. 6, a cross-sectional view through the clamp portion 112 of the rod extension 100 is shown. In accordance with embodiments of the present invention, the clamp portion 112 comprises a deformable body 144 having a receptacle 148 for receiving a portion of the existing rod 120, such as a portion of the existing rod 120 located between two existing pedicle screws 124. The receptacle 148 of the deformable body 144 preferably comprises opposing arms 150a and 150b, where each of the opposing arms 150a and 150b preferably extend beyond an equator E of the existing rod 120.

Referring still to Fig. 6, the deformable body 144 further includes a means for deforming the deformable body 144. As shown in Fig. 6, and in accordance with embodiments of the present invention, the means for deforming comprises a slot 152 within the body 144. The slot 152 separates a first wing 156 of the deformable body 144 from a second wing 160 of the deformable body 144, and allows the two wings 156 and 160 to be displaced relative to each other. As shown in Fig. 6, the means for deforming also comprises a screw 164 for advancement through screw hole 168. As the screw 164 is advanced in the direction of arrow A1 into screw hole 168, the distal end 172 of the screw 164 contacts shoulder 176 of second wing 160. This causes the first wing 156 to separate from the second wing 160. That is, at slot 152, first wing 156 generally moves in the direction of arrow A2, and second wing 160 generally moves in the direction of arrow A3. In turn, the opposing arms 150a and 150b of the deformable body 144 close to pinch or clamp around the existing rod 120. In order to provide sufficient leverage for the screw 164 to separate the two wings 156 and 160, the screw hole 168 is offset from the centerline C of the deformable body 144.



In accordance with embodiments of the present invention, the pedicle screws 124 and 132, and connectors 128 and 136 may allow for angular adjustment of the components. Furthermore, a variety of anchor devices, pedicle screws, connectors, and rods may be used with the present invention. U.S. Patent No. 6,736,816 and U.S. Patent Publication Nos. US 2003-0093078; US 2003-0171751; US 2003-0191470; US 2004-0002708; and US 2004-0181223 are incorporated herein by reference in their entirety.

In a separate aspect of the invention, a method of using the rod extension 100 is provided. In accordance with embodiments of the present invention, the method comprises forming an incision in the patient, the incision not extending the entire length of an existing fusion implant 116 in the patient. Alternatively, the incision could be at least the entire length of the existing implant 116. The surgeon then installs a new pedicle screw 132 into a vertebra beyond the existing fusion implant 116. The rod extension 100 is then loosely interconnected to the newly installed pedicle screw 132, such as by inserting the rod portion 104 of the rod extension 100 into a new connector 136 that is connected to the new pedicle screw 132. The surgeon then adjusts the position of the rod extension 100, including inserting the existing rod 120 into the receptacle 148 of the clamp portion 112 of the rod extension 100. In accordance with the embodiment shown in Figs. 1-6, the surgeon may adjust the orientation of the rod extension 100 by rotating the device, if so desired. That is, an appropriately shaped rod portion 104 and receptacle 148 for the existing rod 120 can allow at least some rotation of the rod extension 100 before tightening the rod extension 100 to the new pedicle screw 132 and existing rod 120. After properly adjusting the position of the rod extension 100, the surgeon can then advance screw 164 of clamp portion 112 to deform the deformable body 144 and secure the existing rod 120 between the opposing arms 150a and 150b of the deformable body 144.

While particular embodiments of the present invention have been described in some detail, it should be understood that other related embodiments are intended to be within the scope of the present invention. For example, other ways to functionally and structurally connect or operatively associate a supplemental rod structure with an existing implant are encompassed by the present invention, whether such structures employ clamping members that are deformable, inter-locking or mating members, or other suitable connection means that are well within the knowledge of those of ordinary skill in this art, be they conventional structures or those that may be developed in the future. In particular, however, other clamping devices that provide an attachment between an existing spinal implant and an extension to the existing

implant are considered within the scope of the invention. More particularly, such devices may include the use of hooks, bolts, adhesives, clamps or alternative orientations of the elements of the present invention to achieve the desired structural relationship between the existing spinal implant and a supplemental rod structure.

The present invention, in various embodiments, includes components, methods, processes, systems and/or apparatus substantially as depicted and described herein, including various embodiments, subcombinations, and subsets thereof. Those of skill in the art will understand how to make and use the present invention after understanding the present disclosure. The present invention, in various embodiments, includes providing devices and processes in the absence of items not depicted and/or described herein or in various embodiments hereof, including in the absence of such items as may have been used in previous devices or processes, *e.g.*, for improving performance, achieving ease and/or reducing cost of implementation.

The foregoing discussion of the invention has been presented for purposes of illustration and description. Any reference to “the invention” is not intended to limit the scope of the claims in any manner, but rather is intended to denote one or more possible embodiments of the claimed invention. The foregoing is not intended to limit the invention to the form or forms disclosed herein. In the foregoing Detailed Description, for example, various features of the invention are grouped together in one or more embodiments for the purpose of streamlining the disclosure. This method of disclosure is not to be interpreted as reflecting an intention that the claimed invention requires more features than are expressly recited in each claim. Rather, as the following claims reflect, inventive aspects lie in less than all features of a single foregoing disclosed embodiment. Thus, the following claims are hereby incorporated into this Detailed Description, with each claim standing on its own as a separate preferred embodiment of the invention.

Moreover, though the description of the invention has included description of one or more embodiments and certain variations and modifications, other variations and modifications are within the scope of the invention, *e.g.*, as may be within the skill and knowledge of those in the art, after understanding the present disclosure. It is intended to obtain rights which include alternative embodiments to the extent permitted, including alternate, interchangeable and/or equivalent structures, functions, ranges or steps to those claimed, whether or not such alternate, interchangeable and/or equivalent structures, functions, ranges or steps are disclosed herein, and without intending to publicly dedicate any patentable subject matter.

What is claimed is:

1. A spinal fusion extension implant for interconnecting to an existing fusion implant in a spine of a patient, the existing fusion implant having at least one existing pedicle screw, at least one existing rod, and at least one existing connector interconnecting the existing pedicle screw to the existing rod, the extension implant comprising:

a rod;

an offset beam connected to said rod; and

a clamp connected to said offset beam;

wherein the clamp is adapted to be secured to the existing rod.

2. The extension implant as claimed in Claim 1, wherein the clamp comprises a receptacle for receiving at least a portion of the existing rod and the receptacle comprises opposing arms that extend around at least an equator of the existing rod.

3. The extension implant as claimed in Claim 1, wherein the clamp comprises a deformable body having a slot with first and second sides, said deformable body having a first wing on said first slot side and a second wing on said second slot side.

4. The extension implant as claimed in Claim 3, further comprising a screw for deforming at least one of said first or second wings away from the other of said first or second wings.

5. The extension implant as claimed in Claim 1, wherein said rod portion and said offset beam are connected by means of a transitional section.

6. A spinal fusion extension implant for interconnecting to an existing fusion implant in a spine of a patient, the existing fusion implant having at least one existing pedicle screw, at least one existing rod, and at least one existing connector interconnecting the existing pedicle screw to the existing rod, the extension implant comprising:

a means for longitudinally stabilizing at least a portion of the spine;

a means for offsetting around at least one of said existing pedicle screw and said existing connector, said means for offsetting connected to said means for longitudinally stabilizing; and

a means for clamping connected to said means for offsetting, wherein said means for clamping secures said means for longitudinally stabilizing and said means for offsetting to the existing rod.

7. A clamp for attaching a first spinal implant member to a second spinal implant member, comprising:

a deformable body;

a receptacle, within said deformable body, for receiving at least a portion of said second spinal implant member, the receptacle comprising opposing arms, wherein the opposing arms extend around at least an equator of the second spinal implant member;

a slot, within said deformable body, wherein said slot separates a first and second wing of said deformable body; and

a screw for tightening said clamp;

wherein said screw operates to separate said first and second wings and wherein said separation results in a deformation of said deformable body, whereby said deformation results in a closing of said receptacle around said at least a portion of said second spinal implant member.

8. The clamp of Claim 7, further comprising:

a screw hole, within said deformable body, extending through said first wing of said deformable body, said screw hole adapted to receive said screw to facilitate contact with said second wing of said deformable body.

9. The clamp of Claim 7, wherein said first spinal implant member comprises:

an offset beam interconnected to said clamp;

a transitional section interconnected to said offset beam; and

a rod interconnected to said transitional section.

10. The clamp of Claim 7, wherein said second spinal implant member comprises a rod portion of an existing spinal implant.

11. A spinal fusion extension implant for interconnecting to an existing fusion implant in a spine of a patient, the existing fusion implant having at least one existing pedicle screw, at least one existing rod, and at least one existing connector interconnecting the existing pedicle screw to the existing rod, the extension implant comprising:

a rod;

a transitional section connected to said rod;

an offset beam connected to said transitional section; and

a clamp connected to said offset beam, said clamp comprising:

a deformable body;

a receptacle, within said deformable body, for receiving at least a portion of said spinal implant member, the receptacle comprising opposing arms that extend around at least an equator of the second spinal implant member;

a slot, within said deformable body, that separates a first and second wing of said deformable body;

a screw hole, within said deformable body, extending through said first wing of said deformable body;

a screw disposed within said screw hole;

whereby said clamp operates by said screw being advanced through said screw hole and through a portion of said slot into contact with said second wing of said deformable body to achieve a separation of said first and second wing, wherein said separation results in a deformation of said deformable body, thereby resulting in a closing of said receptacle around said at least a portion of said existing spinal implant rod.

12. A method for extending a spinal rod, comprising the steps of:

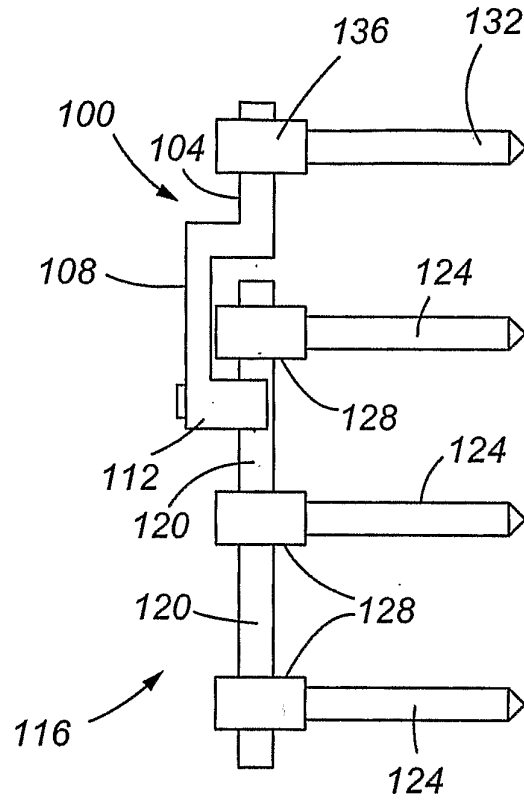
installing a pedicle screw into a vertebra adjacent an existing spinal implant;

connecting said pedicle screw to a portion of a spinal rod extension, having a clamp operatively associated therewith, said clamp having at least one receptacle adapted to receive a rod and being deformable to secure said rod;

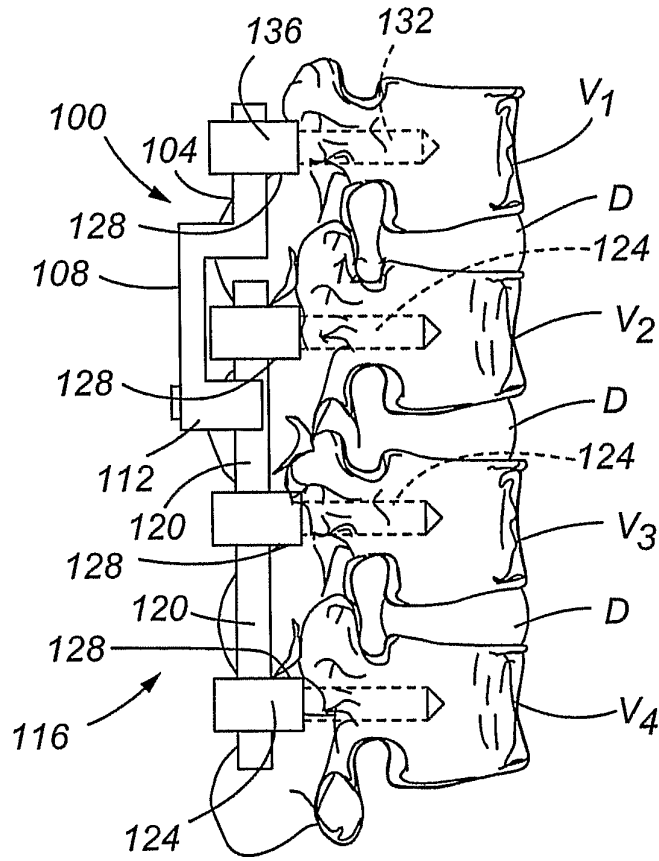
inserting into said receptacle a rod portion of said existing implant; and

deforming said clamp to secure said rod portion of said existing spinal implant.

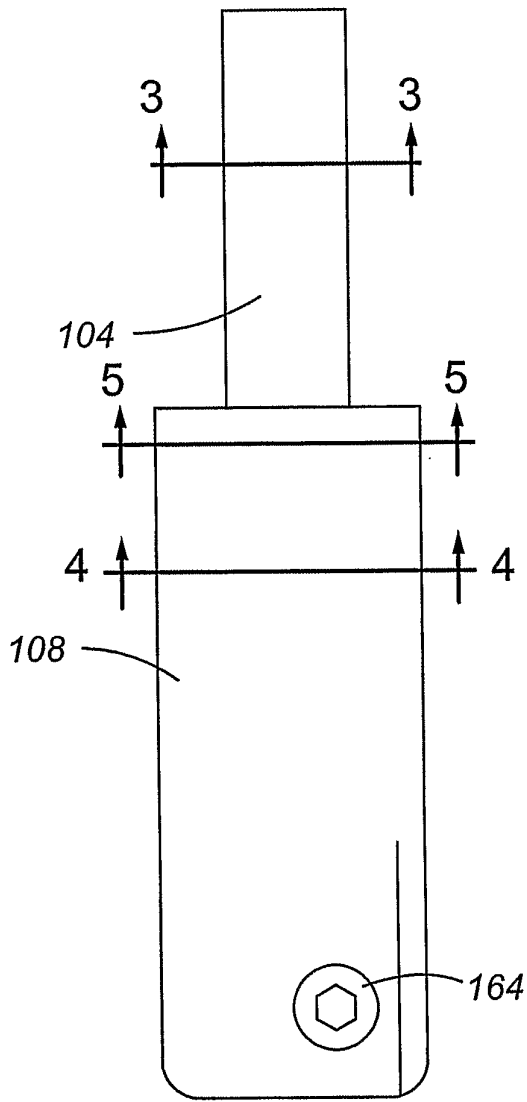
1/4



**Fig. 1a**



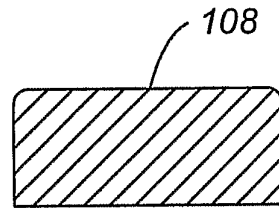
**Fig. 1b**



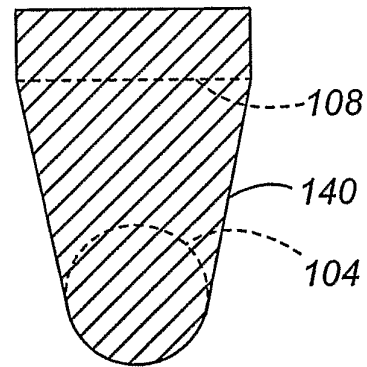
**Fig. 2**



**Fig. 3**

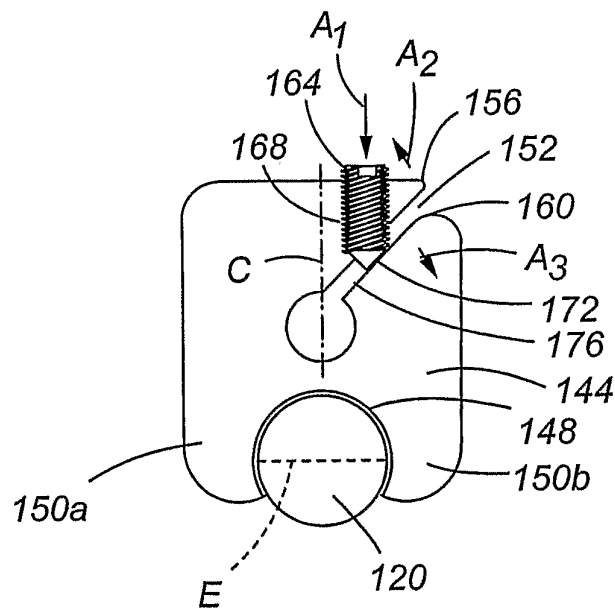


**Fig. 4**



**Fig. 5**





**Fig. 6**