



(19) **United States**

(12) **Patent Application Publication**
Lum et al.

(10) **Pub. No.: US 2013/0016633 A1**

(43) **Pub. Date: Jan. 17, 2013**

(54) **WIRELESS CIRCUITRY FOR
SIMULTANEOUSLY RECEIVING
RADIO-FREQUENCY TRANSMISSIONS IN
DIFFERENT FREQUENCY BANDS**

(52) **U.S. Cl. 370/277; 370/297**

(76) Inventors: **Nicholas W. Lum**, Santa Clara, CA
(US); **Ronald W. Dimpflmaier**, Los
Gatos, CA (US); **Louie J. Sanguinetti**,
Los Gatos, CA (US)

(57) **ABSTRACT**

An electronic device has wireless communications circuitry that includes transmitters and receivers. Antenna structures may be coupled to the transmitters and receivers to support radio-frequency signal transmission and radio-frequency signal reception operations. Switching circuitry such may be used to support multiple communications bands of interest. One or more low band receivers may be associated with the first switch and one or more high band receivers may be associated with the second switch. The switches can be configured in real time to switch a desired communications band into use. A diplexer may be used to simultaneously pass low bands to the first receiver and high bands to the second receiver. In this way, a data stream in the low band may be simultaneously received with a data stream in the high band.

(21) Appl. No.: **13/183,413**

(22) Filed: **Jul. 14, 2011**

Publication Classification

(51) **Int. Cl.**
H04L 5/14 (2006.01)
H04B 7/00 (2006.01)

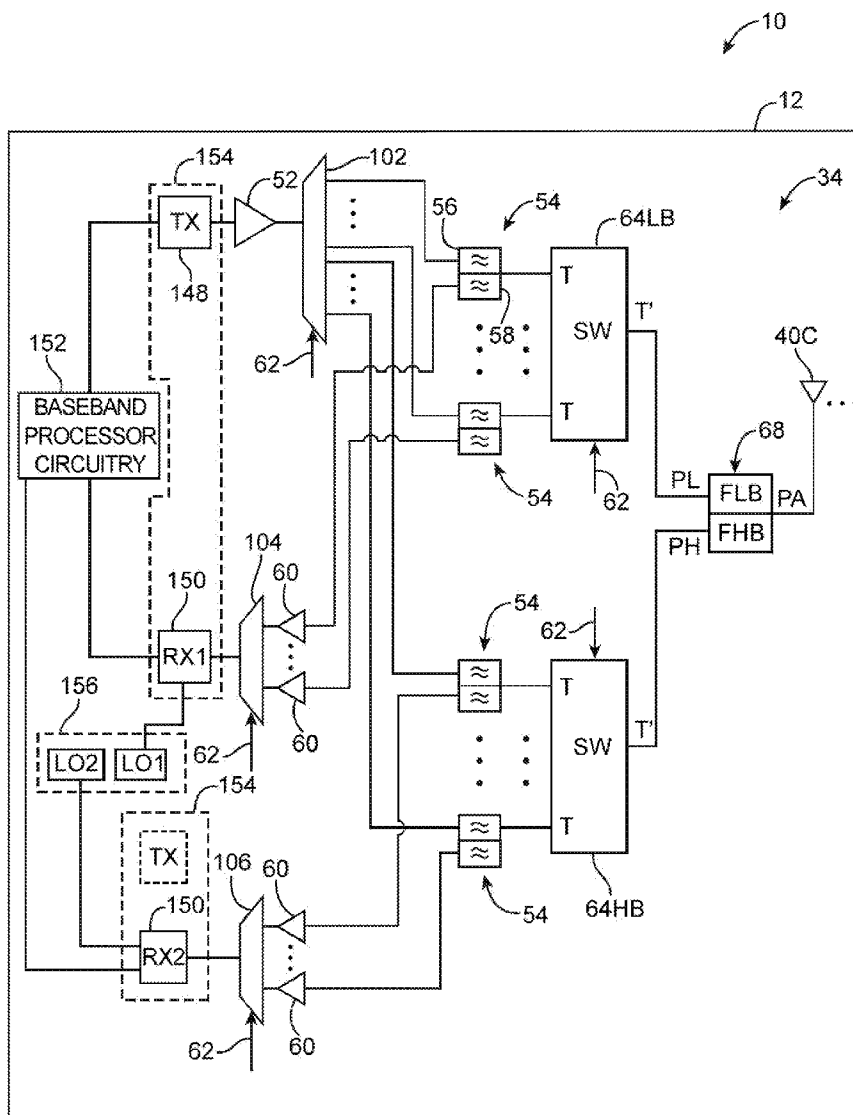

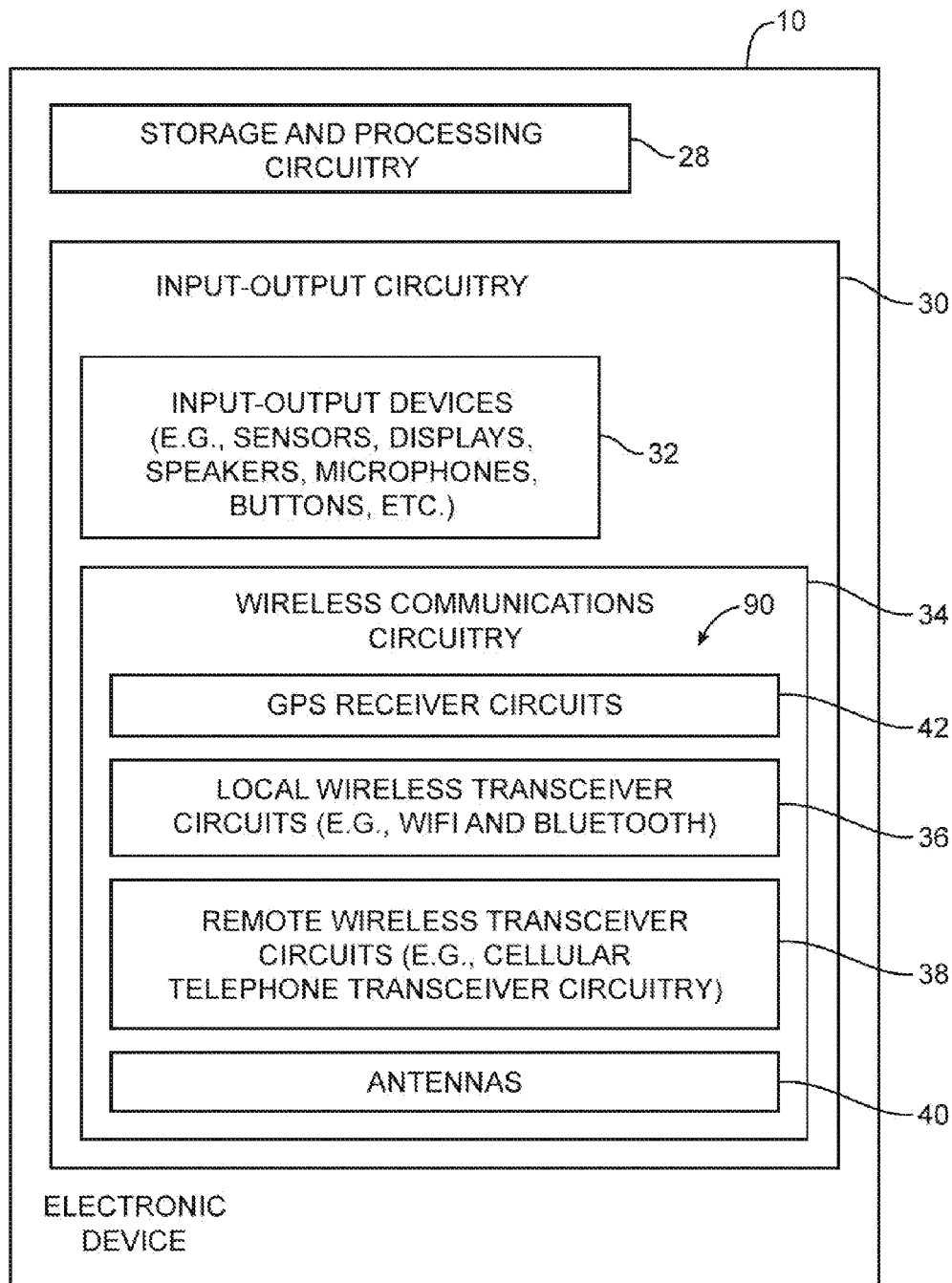

FIG. 1

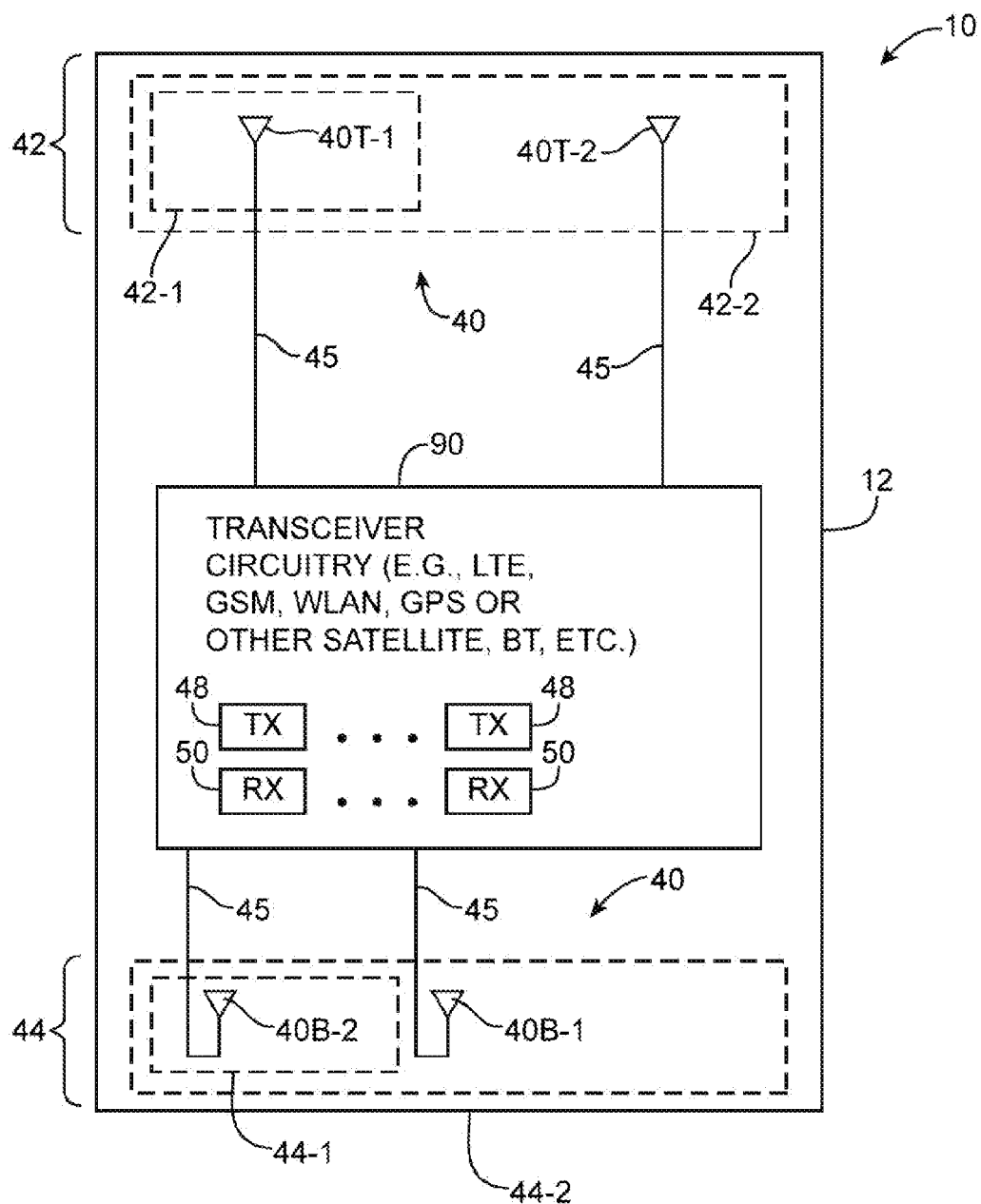

FIG. 2

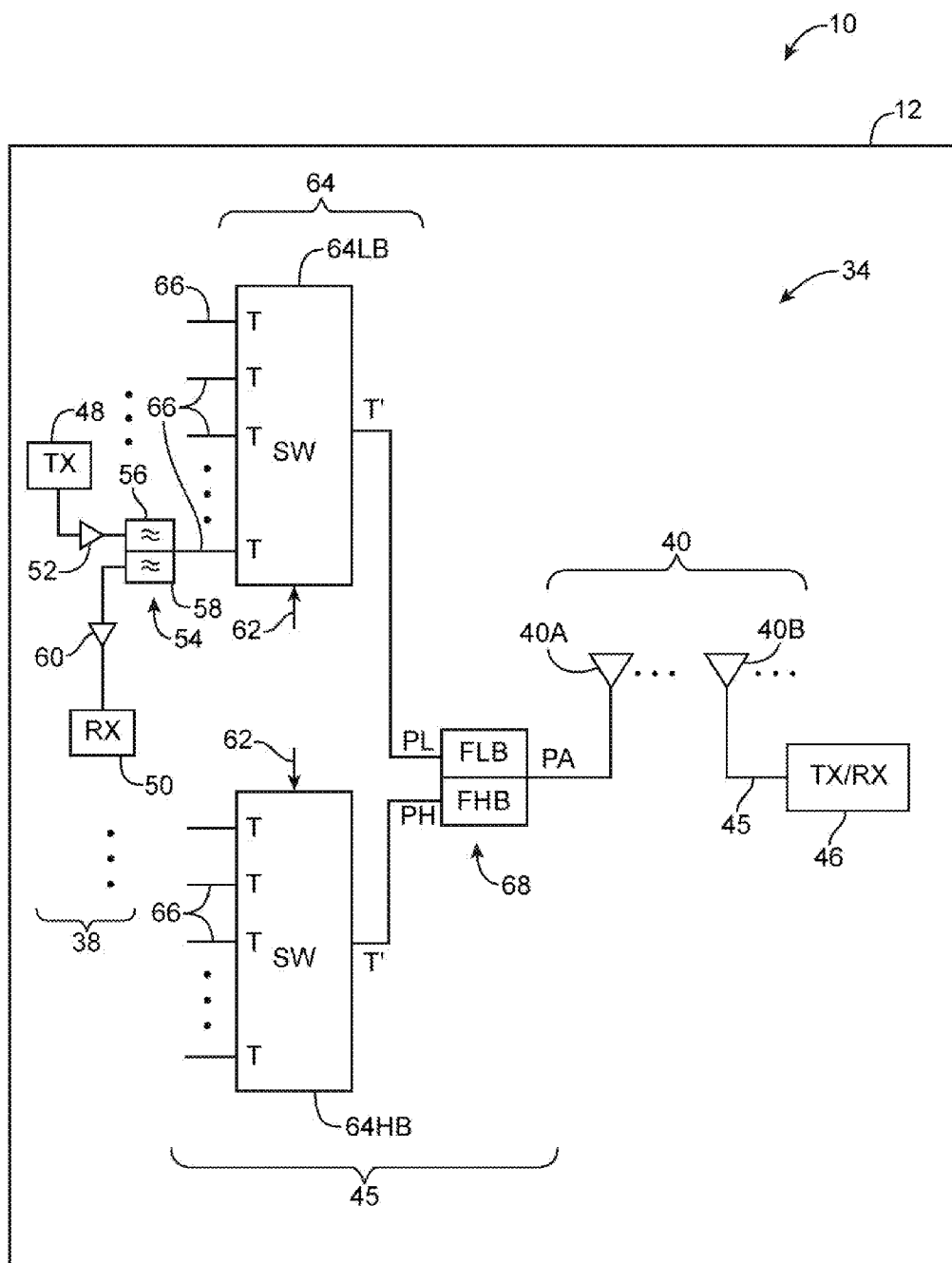

FIG. 3

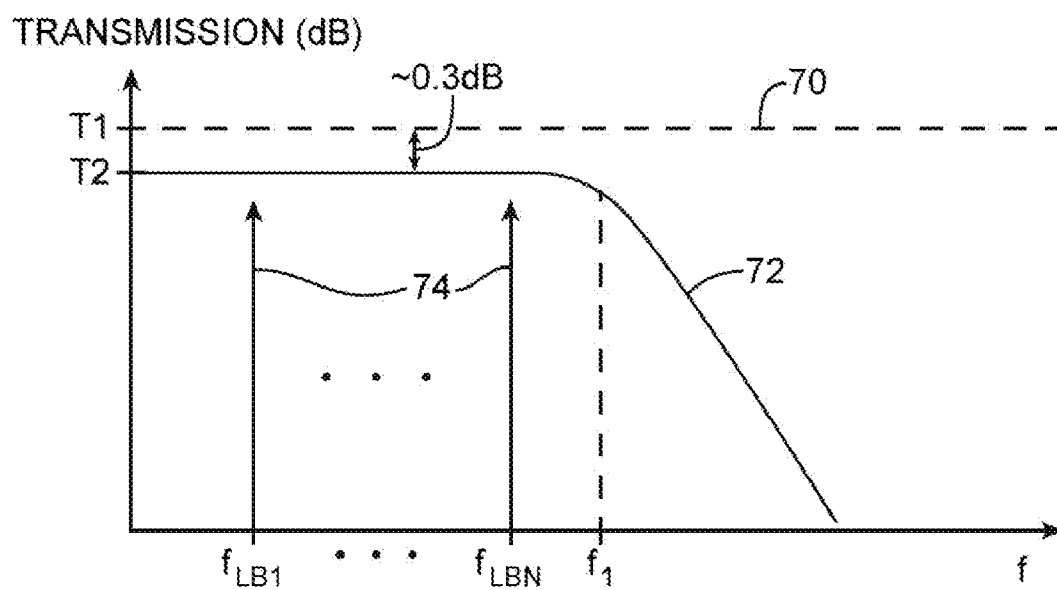

FIG. 4

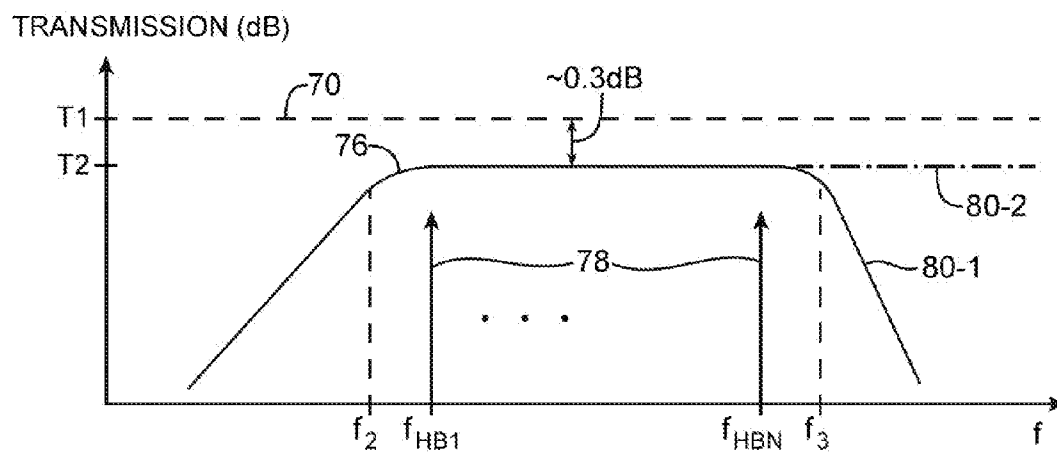

FIG. 5

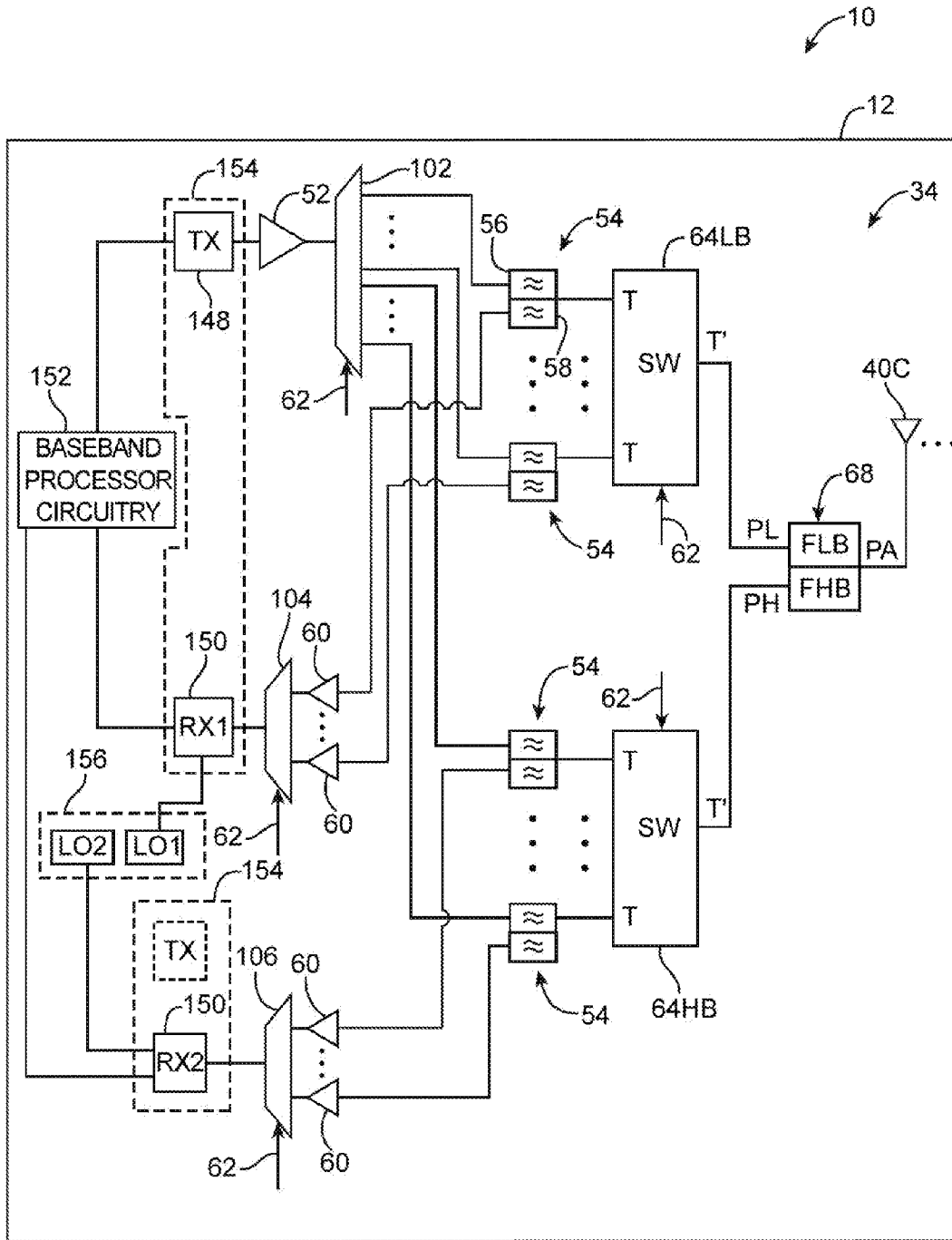

FIG. 6

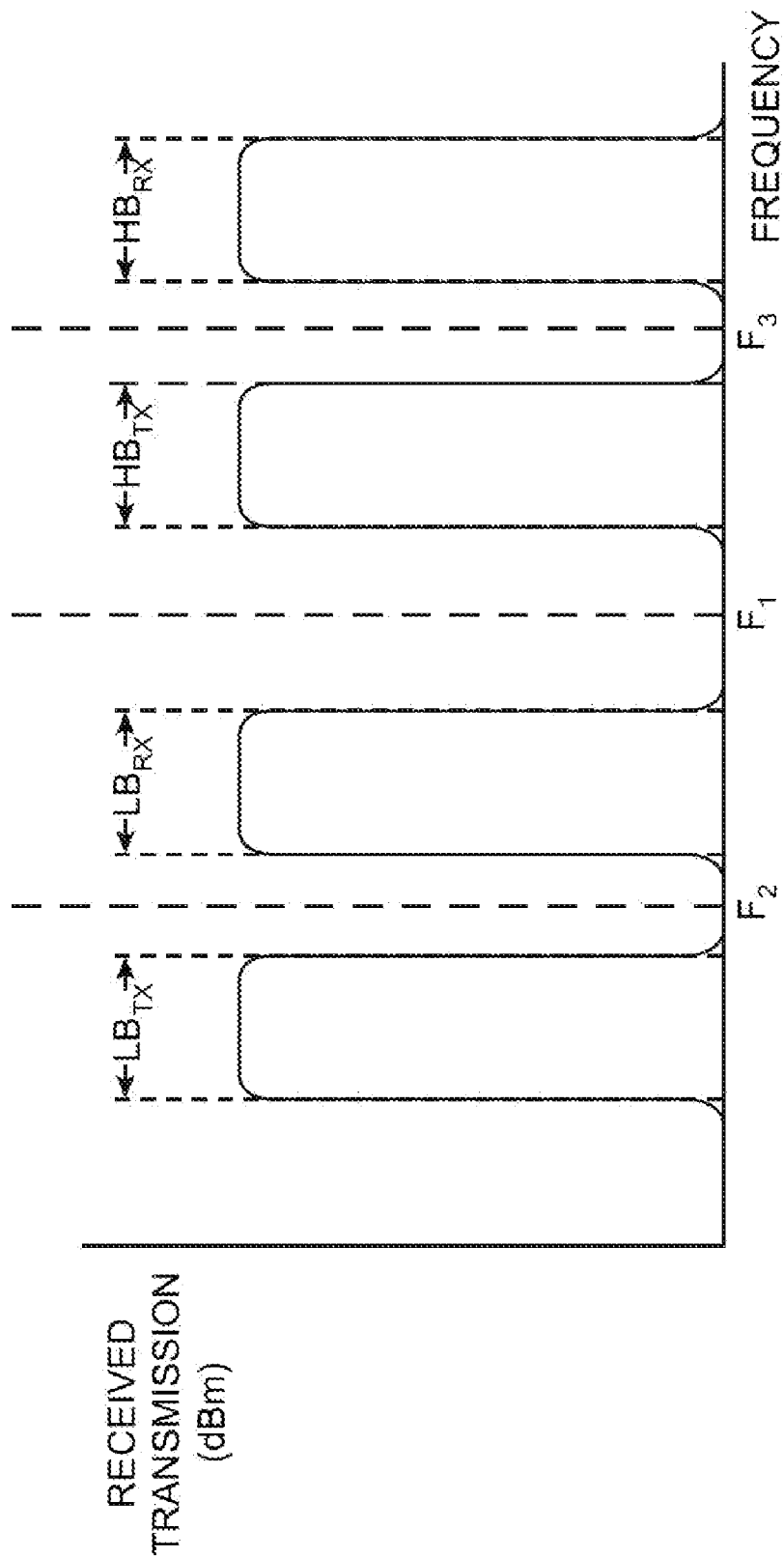

FIG. 7

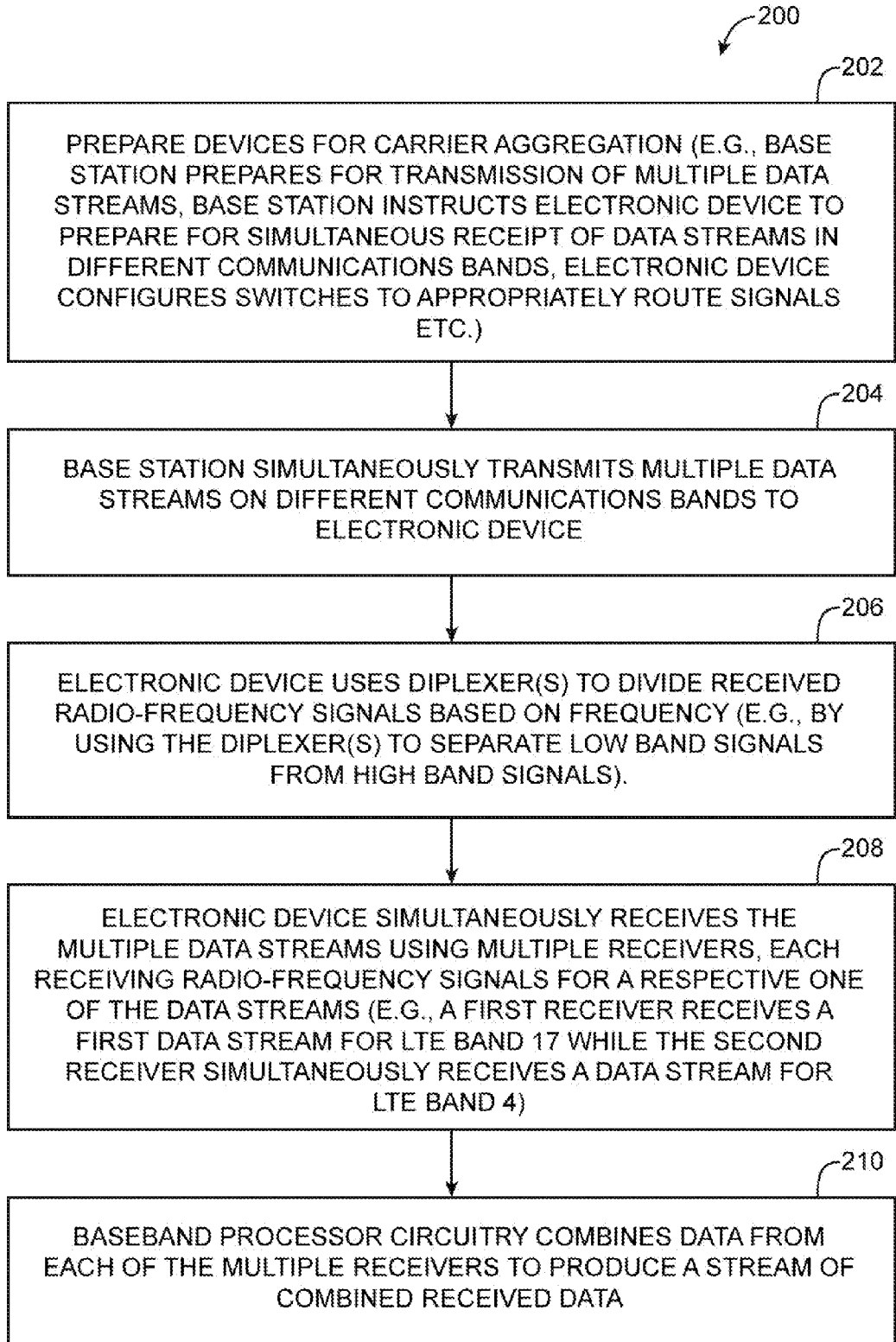

FIG. 8

**WIRELESS CIRCUITRY FOR
SIMULTANEOUSLY RECEIVING
RADIO-FREQUENCY TRANSMISSIONS IN
DIFFERENT FREQUENCY BANDS**

BACKGROUND

[0001] This relates generally to wireless communications circuitry, and more particularly, to circuitry in wireless electronic devices that reduces interference from frequency harmonics and simultaneously receives radio-frequency transmissions in different frequency bands.

[0002] Electronic devices such as computers and cellular telephones are often provided with wireless communications capabilities. For example, electronic devices may use long-range wireless communications circuitry such as cellular telephone circuitry. Global Positioning System (GPS) receiver circuitry and other satellite receiver circuitry may be used to receive satellite navigation signals. Local wireless links may be used to support local area network communications such as IEEE 802.11 communications at 2.4 GHz and 5 GHz. Local links may also be used to handle Bluetooth® communications at 2.4 GHz.

[0003] It is often desirable for a device to support multiple bands. For example, users of a cellular telephone may desire to communicate with cellular telephone towers using one or more different cellular telephone bands and may desire to communicate with local area network equipment using wireless local area network (WLAN) communications bands.

[0004] When supporting multiple bands, it is sometimes desirable to use configurable switching circuitry to route signals. In a device having a transceiver with numerous transceiver ports, for example, a switch may be used to selectively couple a selected one of the transceiver ports to an antenna. This type of configuration allows the device to be configured in different ways, depending on the desired band of operation. If, for example, it is desired to use a first communications band, the switch may be placed in a first state that couples a first transceiver port to the antenna. When it is desired to use a second communications band, the switch may be placed in a second state that couples a second transceiver port to the antenna.

[0005] Radio-frequency switches may be based on components such as transistors that exhibit non-linear behavior. As a result, undesired frequency harmonics may be generated when radio-frequency signals are transmitted through a switch. For example, second harmonics, third harmonics, and higher-order harmonics of transmitted radio-frequency signals may be generated. If care is not taken, these harmonic signals may interfere with the operation of receiver circuitry in the device. For example, harmonics that are generated during transmission of cellular telephone signals may interfere with proper operation of a satellite navigation receiver or wireless local area network receiver.

[0006] Wireless devices may be required to simultaneously receive radio-frequency transmissions in two or more frequency bands. For example, a wireless cellular device that communicates with a base station using a Long Term Evolution (LTE) protocol may be required to receive radio-frequency transmissions from the base station in two separate LTE bands.

[0007] To handle wireless communications in environments such as these, it would be desirable to be able provide

improved circuitry for routing signals between radio-frequency transceiver ports and antenna structures in a wireless electronic device.

SUMMARY

[0008] An electronic device may be provided with wireless communications circuitry. The wireless communications circuitry may include radio-frequency transceiver circuitry for handling wireless communications. The radio-frequency transceiver may have multiple transmitters and multiple receivers. Antenna structures may be used to transmit and receive signals.

[0009] The antenna structures may be coupled to transmitters and receivers in the radio-frequency transceiver circuitry. Switching circuitry such as first and second radio-frequency switches may be used to support multiple communications bands of interest. The first and second radio-frequency switches may be configured in real time to switch desired frequencies into use.

[0010] A set of low band transmitters and receivers may be associated with the first switch and a set of high band transmitters and receivers may be associated with the second switch. As transmitted signals at frequency f pass through the switches, harmonics at $2f$, $3f$, and other integral multiples of the transmitted signals may be produced.

[0011] A diplexer may be interposed between the first and second switches and the antenna structures. The diplexer may have a first port that is coupled to the first radio-frequency switch, a second port that is coupled to the second radio-frequency switch, and a third port that is coupled to one or more antennas in the antenna structures.

[0012] The diplexer may include a low band filter associated with the low band transmitters and receivers and a high band filter associated with the high band transmitters and receivers. The low band filter may be a low pass filter that is coupled between the first switch and the antenna structures. The low pass filter may prevent transmitted signal harmonics that exit the first switch from reaching the antenna structures. The diplexer may include high band and low band filters that exhibit high degrees of linearity such as filters implemented on ceramic substrates. Highly linear filters such as filters with ceramic substrates may have a reduced tendency to produce undesired harmonics relative to other filter designs.

[0013] The high band filter may be a high pass filter or a band pass filter. When implemented using a bandpass filter, the high band filter may prevent transmitted signal harmonics that exit the second switch from reaching the antenna structures.

[0014] The diplexer may be configured to pass low bands to a first receiver and high bands to a second receiver. In this way, a first frequency band may be received and processed by the first receiver and a second frequency band may be received and processed by the second frequency band.

[0015] Further features of the invention, its nature and various advantages will be more apparent from the accompanying drawings and the following detailed description of the preferred embodiments.

BRIEF DESCRIPTION OF THE DRAWINGS

[0016] FIG. 1 is a schematic diagram of an illustrative electronic device with wireless communications circuitry in accordance with an embodiment of the present invention.

[0017] FIG. 2 is a diagram showing how radio-frequency transceiver circuitry may be coupled to one or more antennas within an electronic device of the type shown in FIG. 1 in accordance with an embodiment of the present invention.

[0018] FIG. 3 is a circuit diagram of illustrative wireless communications circuitry of the type that may be used in handling wireless communications in the electronic device of FIG. 1 in accordance with an embodiment of the present invention.

[0019] FIG. 4 is a graph of radio-frequency signal transmission as a function of operating frequency for an illustrative low band filter that may be used in a diplexer within the wireless circuitry of FIG. 3 in accordance with an embodiment of the present invention.

[0020] FIG. 5 is a graph of radio-frequency signal transmission as a function of operating frequency for an illustrative high band filter that may be used in a diplexer within the wireless circuitry of FIG. 3 in accordance with an embodiment of the present invention.

[0021] FIG. 6 is a circuit diagram of illustrative wireless communications circuitry that may be configured to simultaneously receive radio-frequency transmissions in different frequency bands in accordance with an embodiment of the present invention.

[0022] FIG. 7 is a graph of illustrative frequency bands that may be simultaneously received with wireless communications circuitry such as the wireless communications circuitry of FIG. 6 in accordance with an embodiment of the present invention.

[0023] FIG. 8 is a flow chart of illustrative steps that may be performed with a wireless electronic device to simultaneously receive radio-frequency transmissions in different frequency bands in accordance with an embodiment of the present invention.

DETAILED DESCRIPTION

[0024] Electronic devices such as device 10 of FIG. 1 may be provided with wireless communications circuitry. The wireless communications circuitry may be used to support long-range wireless communications such as communications in cellular telephone bands. Examples of long-range (cellular telephone) bands that may be handled by device 10 include the 800 MHz band, the 850 MHz band, the 900 MHz band, the 1800 MHz band, the 1900 MHz band, the 2100 MHz band, the 700 MHz band, and other bands. The long-range bands used by device 10 may include the so-called LTE (Long Term Evolution) bands. The LTE bands are numbered (e.g., 1, 2, 3, etc.) and are sometimes referred to as E-UTRA operating bands. Long-range signals such as signals associated with satellite navigation bands may be received by the wireless communications circuitry of device 10. For example, device 10 may use wireless circuitry to receive signals in the 1575 MHz band associated with Global Positioning System (GPS) communications. Short-range wireless communications may also be supported by the wireless circuitry of device 10. For example, device 10 may include wireless circuitry for handling local area network links such as WiFi® links at 2.4 GHz and 5 GHz, Bluetooth® links at 2.4 GHz, etc.

[0025] As shown in FIG. 1, device 10 may include storage and processing circuitry 28. Storage and processing circuitry 28 may include storage such as hard disk drive storage, non-volatile memory (e.g., flash memory or other electrically-programmable-read-only memory configured to form a solid state drive), volatile memory (e.g., static or dynamic random-

access-memory), etc. Processing circuitry in storage and processing circuitry 28 may be used to control the operation of device 10. This processing circuitry may be based on one or more microprocessors, microcontrollers, digital signal processors, application specific integrated circuits, etc.

[0026] Storage and processing circuitry 28 may be used to run software on device 10, such as internet browsing applications, voice-over-internet-protocol (VOIP) telephone call applications, email applications, media playback applications, operating system functions, functions related to communications band selection during radio-frequency transmission and reception operations, etc. To support interactions with external equipment, storage and processing circuitry 28 may be used in implementing communications protocols. Communications protocols that may be implemented using storage and processing circuitry 28 include internet protocols, wireless local area network protocols (e.g., IEEE 802.11 protocols—sometimes referred to as WiFi®), protocols for other short-range wireless communications links such as the Bluetooth® protocol, cellular telephone protocols, MIMO (multiple input multiple output) protocols, antenna diversity protocols, etc. Wireless communications operations such as communications band selection operations may be controlled using software stored and running on device 10 (i.e., stored and running on storage and processing circuitry 28 and/or input-output circuitry 30).

[0027] Input-output circuitry 30 may include input-output devices 32. Input-output devices 32 may be used to allow data to be supplied to device 10 and to allow data to be provided from device 10 to external devices. Input-output devices 32 may include user interface devices, data port devices, and other input-output components. For example, input-output devices may include touch screens, displays without touch sensor capabilities, buttons, joysticks, click wheels, scrolling wheels, touch pads, key pads, keyboards, microphones, cameras, buttons, speakers, status indicators, light sources, audio jacks and other audio port components, digital data port devices, light sensors, motion sensors (accelerometers), capacitance sensors, proximity sensors, etc.

[0028] Input-output circuitry 30 may include wireless communications circuitry 34 for communicating wirelessly with external equipment. Wireless communications circuitry 34 may include radio-frequency (RF) transceiver circuitry formed from one or more integrated circuits, power amplifier circuitry, low-noise input amplifiers, passive RF components, one or more antennas, transmission lines, and other circuitry for handling RF wireless signals. Wireless signals can also be sent using light (e.g., using infrared communications).

[0029] Wireless communications circuitry 34 may include radio-frequency transceiver circuitry 90 for handling various radio-frequency communications bands. For example, circuitry 34 may include transceiver circuitry 36, 38, and 42. Transceiver circuitry 36 may handle 2.4 GHz and 5 GHz bands for WiFi® (IEEE 802.11) communications and may handle the 2.4 GHz Bluetooth® communications band. Circuitry 34 may use cellular telephone transceiver circuitry 38 for handling wireless communications in cellular telephone bands such as at 850 MHz, 900 MHz, 1800 MHz, 1900 MHz, and 2100 MHz and/or the LTE bands and other bands (as examples). Circuitry 38 may handle voice data and non-voice data.

[0030] Wireless communications circuitry 34 may include global positioning system (GPS) receiver equipment such as GPS receiver circuitry 42 for receiving GPS signals at 1575

MHz or for handling other satellite positioning data. In WiFi® and Bluetooth® links and other short-range wireless links, wireless signals are typically used to convey data over tens or hundreds of feet. In cellular telephone links and other long-range links, wireless signals are typically used to convey data over thousands of feet or miles.

[0031] Wireless communications circuitry 34 may include one or more antennas 40. Antennas 40 may be formed using any suitable antenna types. For example, antennas 40 may include antennas with resonating elements that are formed from loop antenna structure, patch antenna structures, inverted-F antenna structures, slot antenna structures, planar inverted-F antenna structures, helical antenna structures, hybrids of these designs, etc. Different types of antennas may be used for different bands and combinations of bands. For example, one type of antenna may be used in forming a local wireless link antenna and another type of antenna may be used in forming a remote wireless link antenna.

[0032] Antenna diversity schemes may be implemented in which multiple redundant antennas are used in handling communications for a particular band or bands. In an antenna diversity scheme, storage and processing circuitry 28 may select which antenna to use in real time based on signal strength measurements or other data. In multiple-input-multiple-output (MIMO) schemes, multiple antennas may be used to transmit and receive multiple data streams, thereby enhancing data throughput.

[0033] Illustrative locations in which antennas 40 may be formed in device 10 are shown in FIG. 2. As shown in FIG. 2, electronic device 10 may have a housing such as housing 12. Housing 12 may include plastic walls, metal housing structures, structures formed from carbon-fiber materials or other composites, glass, ceramics, or other suitable materials. Housing 12 may be formed using a single piece of material (e.g., using a unibody configuration) or may be formed from a frame, housing walls, and other individual parts that are assembled to form a completed housing structure. The components of device 10 that are shown in FIG. 1 may be mounted within housing 12. Antenna structures 40 may be mounted within housing 12 and may, if desired, be formed using parts of housing 12. For example, housing 12 may include metal housing sidewalls, peripheral conductive members such as band-shaped members (with or without dielectric gaps), conductive bezels, and other conductive structures that may be used in forming antenna structures 40.

[0034] As shown in FIG. 2, antenna structures 40 may be coupled to transceiver circuitry 90 by paths such as paths 45. Paths 45 may include transmission line structures such as coaxial cables, microstrip transmission lines, stripline transmission lines, etc. Paths 45 may also include impedance matching circuitry, filter circuitry, and switching circuitry. Impedance matching circuitry may be used to ensure that antennas 40 are efficiently coupled to transceiver circuitry 90 in communications bands of interest. Filter circuitry may be used to implement frequency-based multiplexing circuits such as diplexers, duplexers, and triplexers. Switching circuitry may be used to selectively couple antennas 40 to desired ports of transceiver circuitry 90. For example, in one operating mode a switch may be configured to route one of paths 45 to a given antenna and in another operating mode the switch may be configured to route a different one of paths 45 to the given antenna. The use of switching circuitry between

transceiver circuitry 90 and antennas 40 allows device 10 to support multiple communications bands of interest with a limited number of antennas.

[0035] In a device such as a cellular telephone that has an elongated rectangular outline, it may be desirable to place antennas 40 at one or both ends of the device. As shown in FIG. 2, for example, some of antennas 40 may be placed in upper end region 42 of housing 12 and some of antennas 40 may be placed in lower end region 44 of housing 12. The antenna structures in device 10 may include a single antenna in region 42, a single antenna in region 44, multiple antennas in region 42, multiple antennas in region 44, or may include one or more antennas located elsewhere in housing 12.

[0036] Antenna structures 40 may be formed within some or all of regions such as regions 42 and 44. For example, an antenna such as antenna 40T-1 may be located within region 42-1 or an antenna such as antenna 40T-2 may be formed that fills some or all of region 42-1. An antenna such as antenna 40B-1 may fill some or all of region 44-2 or an antenna such as antenna 40B-2 may be formed in region 44-1. These types of arrangements need not be mutually exclusive. For example, region 44 may contain a first antenna such as antenna 40B-1 and a second antenna such as antenna 40B-2.

[0037] Transceiver circuitry 90 may contain transmitters such as transmitters 48 and receivers such as receivers 50. Transmitters 48 and receivers 50 may be implemented using one or more integrated circuits (e.g., cellular telephone communications circuits, wireless local area network communications circuits, circuits for Bluetooth® communications, circuits for receiving satellite navigation system signals, power amplifier circuits for increasing transmitted signal power, low noise amplifier circuits for increasing signal power in received signals, other suitable wireless communications circuits, and combinations of these circuits).

[0038] Device 10 may be a relatively large device (e.g. the lateral dimensions of housing 12 may be tens of centimeters or larger) or may be a relatively compact device such as a handheld device that has a longitudinal dimension along the main axis of housing 12 that is 15 cm or less, 10 cm or less, or 5 cm or less, and that has smaller transverse dimensions. In miniature devices such as wrist-mounted, pendant, and clip-mounted devices, the dimensions of housing 12 may be 10 cm or less or 5 cm or less (as examples).

[0039] Particularly in housings for device 10 that are compact, it may be difficult or impossible to widely separate various antennas from each other. For example, some antennas (e.g., antennas 40T-1 and 40T-2 in the example of FIG. 2) may be located adjacent to each other within housing 12. Other antennas (e.g., the antenna structures of region 42 and the antenna structures of region 44) may be separated only by the relatively modest length of device 10.

[0040] Due to the close proximity of the antennas within device 10 in at least some device configurations, there may be a potential for interference between bands. This potential for interference may be exacerbated by the presence of the circuitry in paths 45, which may generate undesirable frequency harmonics. For example, switches in paths 45 may have non-linear properties that lead to the generation of second harmonics, third harmonics, and higher-order harmonics when passing radio-frequency signals.

[0041] During data transmission operations, radio-frequency signals that are generated by transceiver 90 may be transmitted through paths 45 to antennas 40. Transmitted signals may, for example, be generated at a frequency f at one

of the ports associated with transceiver 90. Frequency f may be associated with a cellular telephone band or other frequency of interest. Paths 45 may contain a switch such as a transistor-based switch. As the signals at frequency f pass through the switch (and other non-linear circuit elements in paths 45), frequency harmonics may be generated at frequencies such as $2f$, $3f$, $4f$, and higher. In this situation, a signal harmonic at $2f$, $3f$, $4f$, or higher might be transmitted from one antenna (e.g., a cellular telephone antenna) at the same time that signals at frequency f are being transmitted. The frequency harmonics at $2f$, $3f$, and $4f$ might then be received by another antenna in the device (e.g., a wireless local area network antenna or satellite navigation antenna). If care is not taken, the received signals at harmonic frequencies of frequency f may cause undesirable interference. For example, a received signal at $2f$, $3f$, or $4f$ might fall within or near a communications band of one of receivers 50 (e.g., a wireless local area network receiver or satellite navigation system receiver). Left uncorrected, the presence of this type of interference may prevent satisfactory simultaneous operation of the transmitter at frequency f and the receiver operating at $2f$, $3f$, $4f$, or other harmonic.

[0042] Device 10 can reduce or eliminate this type of undesirable interference by including filtering circuitry in paths 45 that blocks harmonics associated with transmitted signals before they reach antennas 40. Because the magnitude of transmitted harmonics is substantially reduced, the magnitude of any harmonics that are received by other antenna and receiver circuitry in device 10 is substantially reduced. By effectively preventing harmonics from being transmitted, the potential for signal interference is eliminated and satisfactory device operation is ensured.

[0043] The filtering circuitry may include a diplexer filter that is used to multiplex low band and high band transmitted signals onto a common transmit path. During signal reception operations, the diplexer demultiplexes received signals based on their frequency. The diplexer may include a low pass filter that is coupled to low band transceiver ports through a low band switch. The diplexer may also include a high pass filter or a bandpass filter that is coupled to high band transceiver ports through a high band switch.

[0044] Even if harmonics are generated in the switches, the harmonics will be blocked by the filtering circuitry of the diplexer. For example, consider a low band frequency such as frequency f . As a signal at this frequency passes through the low band switch, harmonic signals at $2f$, $3f$, and $4f$ may be generated. By proper configuration of the cutoff frequency of the low pass filter, signal frequency f will fall within the pass band of the low pass filter, but signal frequencies $2f$, $3f$, and $4f$ will fall outside of the pass band and will be attenuated. Because the low pass filter blocks undesired harmonic frequencies, receivers 50 in device 10 that operate at or near harmonic frequencies (e.g., $2f$, $3f$, $4f$, and higher) will not be subject to harmonic interference and can operate at the same time as the transmitter operating at frequency f . Frequency harmonics generated when transmitting signals from the high band transceiver through the high band switch can likewise be attenuated by the high-frequency attenuation properties of the high-band filter (i.e., when the high-band filter is implemented using a bandpass filter that passes desired high-band frequencies while attenuating harmonics of these desired high-band frequencies).

[0045] A filtering arrangement based on a diplexer scheme of this type may exhibit lower insertion loss than filtering

arrangements based on components with higher insertion losses such as notch filters. If desired, additional filtering circuitry may be used in device 10. In general, the filtering circuitry in paths 45 may include diplexers, duplexers, triplexers, notch filters, bandpass filters, low pass filters, high pass filters, other filter components, and combinations of filter circuits such as these. Filtering components may, for example, be implemented using surface acoustic wave (SAW) or bulk acoustic wave (BAW) devices.

[0046] An illustrative configuration that may be used for wireless communications circuitry 34 is shown in FIG. 3. As shown in FIG. 3, device 10 may include antennas 40 in housing 12. Antennas 40 may be coupled to transceiver circuitry 38 and 46 using paths 45. Paths 45 may include switching circuitry 64.

[0047] Antennas 40 may include one or more antennas. One or more antennas 40 may, for example, be used for cellular telephone communications bands, one or more antennas 40 may be used for satellite navigation system bands such as the GPS band at 1575 MHz, and one or more antennas 40 may be used for other communications bands of interest (e.g. the IEEE 802.11 bands at 2.4 GHz and 5 GHz or other wireless local area network bands, the Bluetooth® band at 2.4 GHz, etc.). In a configuration of the type shown in the example of FIG. 3, one or more antennas such as antenna 40A may be associated with wireless transceiver circuitry such as remote wireless transceiver circuitry 38 (e.g., one or more cellular telephone transceiver circuits) and one or more antennas such as antenna 40B may be associated with wireless transceiver circuitry 46 (e.g., satellite navigation system receiver 42 of FIG. 1, local wireless transceiver circuits 36 of FIG. 1 such as IEEE 802.11 wireless local area network circuits, Bluetooth® circuits, etc.). Additional antennas may be associated with transceiver circuitry 38 (i.e., antennas in addition to antenna 40A) and additional antennas may be associated with transceiver circuitry 46 (i.e., antennas in addition to antenna 40B), if desired.

[0048] Transceiver circuitry 38 may include transmitters 48 and receivers 50. There may be, for example, a respective transmitter 48 and a respective receiver 50 associated with each of a plurality of cellular telephone communications bands. Consider, as an example, LTE Band 13. To support communications in E-UTRA (LTE) Band 13, one of transmitters 48 (e.g., transmitter TX of FIG. 3) may transmit radio-frequency signals in the uplink frequency range of 777 MHz to 787 MHz and one of receivers 50 (e.g., receiver RX of FIG. 3) may receive radio-frequency signals in the downlink frequency range of 746 MHz to 756 MHz. To increase transmit power before transmitted radio-frequency signals reach antennas 40, paths 45 may include power amplifiers such as power amplifier 52. To increase the strength of signals that have been received from antennas 40, paths 45 may include low noise amplifiers (LNAs) such as low noise amplifier 60. Amplifiers such as amplifiers 52 and 60 may be implemented using discrete components, using circuitry that is part of a transceiver integrated circuit, etc.

[0049] Switching circuitry 64 may include multiple switches each of which is associated with a respective frequency range. In the example of FIG. 3, switching circuitry 64 includes first switch 64LB and second switch 64HB. The states of switches 64LB and 64HB (i.e., which terminals are connected to each other in the switches) may be controlled by using storage and processing circuitry 28 to apply control signals to control terminals 62. Switch 64LB may be used to

handle radio-frequency signals with lower frequencies than switch 64HB. With this type of arrangement, switch 64LB may sometimes be referred to as a low band switch and switch 64HB may sometimes be referred to as a high band switch.

[0050] Switches 64LB and 64HB preferably have a sufficient number of terminals (switch ports) to allow all desired transmitters 48 and receivers 50 to be coupled to antennas 40. In a typical configuration, switches 64LB and 64HB may be SP4T (single pole four throw) or SP5T (single pole five throw) switches (as an example). Switches with more terminals or fewer terminals may be used if desired.

[0051] Each switch has one terminal T' that is coupled to diplexer 68 and a plurality of other terminals T that are each coupled to a respective portion of transceiver circuitry 38. In a typical configuration, each transmitter and receiver pair in transceiver circuitry 38 is coupled to a respective terminal T in switch 64LB or 64HB using a component such as diplexer 54. With this type of arrangement, transmit and receive signals for each band of interest are associated with a respective switch terminal T.

[0052] Each diplexer 54 may be a three port device that has a first port coupled to a transceiver, a second port coupled to a receiver, and a third port coupled to one of terminals T. Diplexer 54 may be formed from filter circuitry that provides high isolation between the first port and the second port. For example, a diplexer 54 may be configured to accommodate radio-frequency transmissions associated with LTE band 5. In this scenario, the first port of diplexer 54 may be coupled to a transceiver that transmits radio-frequency signals on the LTE band 5 transmit frequencies (e.g., 824 MHz to 849 MHz) and the second port of diplexer 54 may be coupled to a receiver that receives radio-frequency signals on the LTE band 5 receive frequencies (e.g., 869 MHz to 894 MHz). The radio-frequency signals transmitted by the transceiver may be much larger than the radio-frequency signals received by the receiver (e.g., tens of dBm larger). Diplexer 54 may help prevent the relatively large signals transmitted by the transceiver from being received by the receiver, thereby providing high isolation between the transceiver and the receiver. In other words, diplexer 54 may provide high out-of-band attenuation for the first and second ports of diplexer 54.

[0053] In the example of FIG. 3, low band switch 64LB has a plurality of terminals T each of which is coupled to a respective transmitter 48 and receiver 50 by a respective path 66 and associated filter circuitry such as diplexer 54. For example, transmitter TX may be connected to filter 56 in diplexer 54 and receiver RX may be connected to filter 58 in diplexer 54. Filter 56 may be a band pass filter that passes signals in the uplink range of Band 13 and filter 58 may be a band pass filter that passes signals in the downlink range of Band 13.

[0054] Diplexer 54 may be coupled to a given one of terminals T in low band switch 64LB by one of paths 66. Transmitted signals from transmitter TX in the uplink frequency range for Band 13 may be routed to the given terminal T by power amplifier 52 and filter 56 of diplexer 54. Received signals in the downlink frequency range for Band 13 may be routed from the given terminal T to receiver RX by filter 58 and low noise amplifier 60. Other bands (e.g., other LTE bands, GSM bands, etc.) may be handled using their own respective transmitters 48, power amplifiers 52, receivers 50, low noise amplifiers 60, and diplexer 54.

[0055] The transceiver circuitry for a first set of the frequency bands handled by transceiver circuitry 38 (e.g., the

lower frequency bands) may be coupled to the terminals T of low band switch 64LB. The transceiver circuitry for a second set of the frequency bands handled by transceiver circuitry 38 (e.g., the higher frequency bands) may be coupled to the terminals T of high band switch 64HB. With one suitable arrangement, frequencies below about 960 MHz may be handled by low band switch 64LB and frequencies above about 1710 MHz may be handled by high band switch 64HB. Other configurations may be used in wireless circuitry 34 if desired. These frequency assignments are merely illustrative.

[0056] Diplexer 68 may have filters FLB and FHB and ports (terminals) PL, PH, and PA. Terminal T' of switch 64LB may be coupled to port PL. Terminal T' of switch 64HB may be coupled to port PH. Port PA of diplexer 68 may be coupled to antenna 40A. Filter FLB may be a low pass filter. Filter FHB may be a high pass filter or a bandpass filter. Diplexer 68 may use filters FLB and FHB to route radio-frequency signals between switching circuitry 64 and antenna 40A according to frequency, while blocking undesired signal harmonics.

[0057] FIG. 4 is a graph showing an illustrative radio-frequency signal transmission characteristic that may be associated with filter FLB. As shown in FIG. 4, filter FLB may be a low pass filter that passes signals with frequencies f below frequency f_1 . The value of f_1 may be, for example, 960 MHz or other frequency that is above the frequencies $f_{LB1} \dots f_{LBN}$ of the communications bands that are being transmitted and received via switch 64LB. Using low pass filter FLB, diplexer 68 may exhibit an insertion loss of about 0.3 dB between ports PL and PA (i.e., maximum transmission value T2 of filter FLB may be about 0.3 dB below 100% transmission level T1, as indicated by the gap between 100% transmission curve 70 and transmission curve 72 of filter FLB).

[0058] FIG. 5 is a graph showing an illustrative radio-frequency signal transmission characteristic that may be associated with filter FHB. As shown in FIG. 5, filter FLB may be a high pass filter (see, e.g., curve 76 and curve portion 80-2) or a bandpass filter (see, e.g., curve 76 and curve portion 80-1) that passes signals with frequencies f above frequency f_2 . The value of f_2 may be, for example, 1710 MHz or other frequency that is below the frequencies $f_{H1} \dots f_{HN}$ of the communications bands that are being transmitted and received via switch 64HB. Using high pass filter (or bandpass filter) FLB, diplexer 68 may exhibit an insertion loss of about 0.3 dB between ports PH and PA. As shown in FIG. 5, for example, the maximum transmission value T2 of filter FHB may be about 0.3 dB below 100% transmission level T1, as indicated by the gap between 100% transmission curve 70 and transmission curve 76 of filter FHB (diplexer 68). The insertion losses associated with diplexer 68 may be somewhat higher or lower than the illustrative 0.3 dB insertion loss shown in FIGS. 4 and 5. Nevertheless, the insertion losses associated with use of a diplexer such as diplexer 68 will generally be significantly less than the insertion losses that would result if other types of filtering circuitry such as notch filters were to be interposed between switching circuitry 64 and antenna 40A.

[0059] Switching circuitry 64 may be implemented using switches 64A and 64B that include gallium arsenide field-effect transistors (FETs), microelectromechanical systems (MEMS) switches, metal-oxide-semiconductor field-effect transistors (MOSFETs), p-i-n diodes, high-electron mobility transistors (HEMTs), pseudomorphic HEMI (PHEMTs), transistors formed on a silicon-on-insulator (SOI) substrate, etc. When radio-frequency signals are transmitted from trans-

mitters 48 to antenna 40A, the transmitted signals pass through switching circuitry 64. Nonlinearities in the behavior of switching circuitry 64 may generate harmonics at terminals T' (i.e., at the outputs of the switches). The filters of diplexer 68 can significantly attenuate these harmonics, so that the harmonics are not transmitted through antenna 40A and are therefore not received by antenna 40B. Because antenna 40B does not receive harmonics of any significant magnitude, the receivers associated with transceiver 46 (i.e., wireless local area network receiver circuitry, satellite navigation receiver circuitry, etc.) will operate properly without interference from the operation of transceiver circuitry 38.

[0060] Consider, as an example, a situation in which the communications bands that pass through low band switch 64LB and low pass filter FLB (i.e., bands 74 at frequencies $f_{LB1} \dots f_{LBN}$ of FIG. 4) are associated with LTE bands such as some or all of Bands 5, 8, 17, 13, and 20 (and, if desired, other LTE bands and/or other cellular telephone bands), whereas the communications bands that pass through high band switch 64HB and high pass filter (or bandpass filter) HLB (i.e., bands 78 at frequencies $f_{HB1} \dots f_{HBN}$ of FIG. 5) are associated with LTE bands such as some or all of Bands 4, 2, 7, 1, 3, and 40 (and, if desired, other LTE bands and/or other cellular telephone bands). In a configuration of this type, harmonics of some of the transmitted LTE bands may fall within IEEE 802.11 (WiFi®) bands at 2.4 GHz and 5 GHz and/or satellite navigation system bands such as the GPS band at 1575 MHz. For example, the uplink (transmit) band associated with Band 13 extends from 777 MHz to 787 MHz. When Band 13 traffic is transmitted by transceiver circuitry (e.g., transmitter TX of FIG. 3), switch 64LB may generate harmonics such as second harmonics in the frequency range of 1554 MHz to 1574 MHz. If not attenuated by diplexer 68, these second harmonics (particularly the harmonic signals near 1574 MHz) might interfere with the GPS band centered at 1575 MHz (i.e., the GPS receiver coupled to antenna 40A). By using diplexer 68, however, the second harmonics in the frequency range of 1554 MHz to 1574 MHz are attenuated significantly (e.g., by 15 dB or more, by 30 dB or more, etc.). As shown in FIG. 4, for example, low pass filter FLB significantly attenuates signals at frequencies above f1 (e.g., above 960 MHz or other suitable cutoff frequency).

[0061] The third harmonics of LTE bands 1, 3, 4, and 2 may represent a possible source of interference with the IEEE 802.11 wireless local area network band at 5 GHz. When signals in these LTE bands are transmitted through switch 64HB, third harmonics in the vicinity of 5 GHz may be produced. As indicated by curve 76 and, in particular, curve segment 80-1 of FIG. 5, when filter FHB is implemented as a bandpass filter (i.e., when filter FHB passes signals in a frequency range f2 to f3 of about 1710 MHz to 2.25 GHz), signals above 2.25 GHz (i.e., the harmonics in the vicinity of 5 GHz) will be attenuated by filter FHB. As with the second harmonics of Band 13 that are attenuated by filter FLB, these harmonics will not reach antenna 40B. Because diplexer 68 prevents transmitted signal harmonics from being transmitted through antenna 40B, these harmonics will not be received by antenna 40A, even when antennas 40A and 40B are located within the same device (e.g., at ends 44 and 42, respectively) and are potentially in close proximity to each other (e.g., 15 cm or less apart, etc.).

[0062] If desired, the lower cutoff frequency f2 and upper cutoff frequency f3 of high band filter FHB may be lower or higher to accommodate different transmitted bands. If no

receiver is used in device 10 at 5 GHz, filter FHB may be implemented using a high pass filter (i.e., filter with a low frequency cutoff such as frequency f2 of FIG. 5, but no sharp upper frequency cutoff such as frequency f3 so that curve 76 follows segment 80-2 above f3). Low band filter FLB can be implemented using different cutoff frequencies. The use of a 960 MHz cutoff frequency for frequency f1 of FIG. 1 is presented as an example.

[0063] It may be desirable to simultaneously receive radio-frequency transmissions in two different frequency bands. For example, device 10 may communicate with a cellular base station using a Long Term Evolution (LTE) protocol. In this type of communications environment, a cellular base station may expect device 10 to receive data using two different LTE communications bands (sometimes referred to as carrier aggregation). As an example, the base station may require device 10 to simultaneously receive data on LTE band 4 and LTE band 17. To receive data on LTE band 4, device 10 may be configured to accommodate frequencies from 2110 MHz to 2155 MHz. To receive data on LTE band 17, device 10 may be configured to accommodate frequencies from 734 MHz to 746 MHz.

[0064] By receiving data using two different communications bands, device 10 may be provided with increased bandwidth. For example, a device 10 that simultaneously receives data streams in LTE band 4 and LTE band 17 may be provided with a communications bandwidth equal to the combination of the respective bandwidths of LTE band 4 and LTE band 17 (e.g., 45 MHz from LTE band 4 added to 12 MHz from LTE band 17). In this way, device 10 may be provided with improved data transmissions rates.

[0065] In the illustrative embodiment of FIG. 6, device 10 has been provided with wireless communications circuitry 34 that is configured to simultaneously receive radio-frequency transmissions in different frequency bands. The embodiment of FIG. 6 may correspond to the wireless communications circuitry 34 of FIG. 3 in which a single transmitter and two receivers are multiplexed with switching circuitry (e.g., switching circuitry 102, 104, and 106) to accommodate all communications bands.

[0066] As shown in FIG. 6, wireless communications circuitry 34 may include an antenna such as antenna 40C that receives wireless transmissions (e.g., from a cellular base station). The received wireless transmission may be provided to diplexer 68 via diplexer port PA. Diplexer 68 may include circuitry that routes signals according to frequency. For example, diplexer 68 may have filters FLB (e.g., a low pass filter) and FHB (e.g., a high pass filter) that divide received wireless transmissions into low frequencies and high frequencies, respectively, while minimizing signal loss (e.g., while minimizing insertion loss). Received signals with low frequencies may be routed to terminal T' of switch 64LB from diplexer port PL. Received signals with high frequencies may be routed to terminal T' of switch 64HB from diplexer port PH. During signal transmission, low band signals at port PL and high band signals at port PH may be combined by diplexer 68 and the resulting combined signals may be output at port PA.

[0067] Switches 64LB and 64HB may each have one or more terminals T. Switches 64LB and 64HB may be electrically controllable switches (e.g., transistor-based switches) that may each be configured via control terminals 62 to couple a selected one of terminals T to terminal T'. Each terminal T of switches 64LB and 64HB may be coupled to a respective

one of duplexers 54. Duplexers 54 may each have respective high and low band filters. For example, each duplexer may have a first filter such as filter 56 and a second filter such as filter 58. Filter 56 and filter 58 may separate radio-frequency signals into separate frequency bands corresponding to a transmit frequency bands and a receive frequency bands. Filters 56 may isolate frequencies that correspond to transmit (uplink) frequencies and provide the isolated frequencies to switching circuit 102. Switching circuit 102 may be configurable via control terminal 62 to couple transmitter TX to a desired duplexer 54. Filters 58 may isolate frequencies that correspond to receive (downlink) frequencies. By configuring the frequency responses of filters 56 and 58, each duplexer 54 (and an associated terminal T) may be configured to handle signals associated with a particular communications band. For example, a first terminal T may be associated with LTE band 4 and a second terminal T may be associated with LTE band 17.

[0068] To simultaneously receive radio-frequency transmissions in different frequency bands, filters 58 that are coupled to switch 64LB may be coupled to switching circuit 104 and filters 58 that are coupled to switch 64HB may be coupled to switching circuit 106. Switching circuitry 104 and 106 may be implemented using electrically controllable switches (e.g., transistor-based switches) that are configurable via control terminals 62. Switch 104 may be coupled to receiver RX1 and switch 106 may be coupled to receiver RX2. Receiver RX1 may receive radio-frequency signals that correspond to relatively low frequencies. Receiver RX2 may receive radio-frequency signals that correspond to relatively high frequencies.

[0069] As an example, a device 10 that communicates with a base station using the LTE standard may simultaneously receive radio-frequency transmissions in band 4 (e.g., a frequency band that corresponds to relatively high frequencies) and band 17 (e.g., a frequency band that corresponds to relatively low frequencies). In this scenario, the radio-frequency transmissions received by device 10 via antenna 40C may be partitioned by diplexer 68 into signals that correspond to band 4 and signals that correspond to band 17.

[0070] The signals that correspond to band 4 may be received by switch 64HB and forwarded to a first duplexer 54 that is configured to accommodate the frequencies associated with band 4. The first duplexer 54 may partition the frequencies associated with band 4 into a transmit band and a receive band (e.g., a transmit band corresponding to 1710 MHz through 1755 MHz and a receive band corresponding to 2110 MHz through 2155 MHz) and provide the signals associated with the receive band to multiplexer 106 and receiver RX2. Receiver RX2 may process the signals associated with the receive band (e.g., receiver RX2 may demodulate the signals and provide the signals to a baseband processor).

[0071] The signals that correspond to band 17 may be received by switch 64LB and forwarded to a second duplexer 54 associated with band 17. The second duplexer 54 may partition the frequencies associated with band 17 into a transmit band and a receive band (e.g., a transmit band corresponding to 704 MHz through 716 MHz and a receive band corresponding to 734 MHz through 746 MHz) and provide the signals associated with the receive band to multiplexer 104 and receiver RX1 for processing.

[0072] To allow receiver RX1 and RX2 to simultaneously receive radio-frequency signals in different communications bands, each receiver may be coupled to a respective local

oscillator. Receiver RX1 may be coupled to local oscillator LO1 and receiver RX2 may be coupled to local oscillator LO2. Local oscillators LO1 and LO2 may generate signals with appropriate frequencies (e.g., sinusoidal signals or other desired signals with appropriate frequencies) for receivers RX1 and RX2 to use for processing radio-frequency signals. For example, receiver RX1 may receive radio-frequency signals corresponding to LTE band 17. In this scenario, local oscillator LO1 may be tuned to provide a signal with an appropriate frequency for demodulating radio-frequency signals associated with LTE band 17.

[0073] The use of two separate local oscillators LO1 and LO2 to provide receivers RX1 and RX2 with respective signals is merely illustrative. If desired, local oscillating circuitry 156 may provide receivers RX1 and RX2 with two signals with different frequencies. For example, local oscillating circuitry 156 may include a single local oscillator configured to generate a first signal at a first frequency and the first signal may be provided to receiver RX1. Local oscillating circuitry 156 may also include frequency dividing circuitry configured to use the first signal to generate a second signal at a second frequency and the second signal may be provided to receiver RX2.

[0074] In this way, radio-frequency transmissions that are received by device 10 may be simultaneously processed. By simultaneously processing two different frequency bands, device 10 may be provided with increased communications bandwidth, thereby increasing data rates.

[0075] The use of the circuitry of FIG. 6 to handle signals associated with LTE bands 4 and 17 is merely illustrative. Any two different communications bands may be simultaneously received by configuring wireless communications circuitry 34 to accommodate the desired frequency bands. For example, LTE band 2 may be simultaneously received with LTE band 17, LTE band 5, the MediaFLO band, or other desired frequency bands. As another example, LTE band 4 may be simultaneously received with LTE band 5 or the MediaFLO band, LTE band 1 may be simultaneously received with LTE band 8 or with LTE band 20, LTE band 3 may be simultaneously received with LTE band 8 or band 20, etc. If desired, more than two frequency bands may be simultaneously handled in this way. For example, multiple duplexers may be arranged in stages to divide received radio-frequency signals into a desired number of frequency bands that are processed by respective receivers.

[0076] Receivers RX1 and RX2 may be formed as part of transceiver circuitry or as separate circuits. For example, receiver RX1 and/or receiver RX2 may be combined with transmitter TX to form a transceiver or may be implemented separately as distinct receiver and transmitter circuits. If desired, a first optional transceiver 154 may be formed from the combination of receiver RX1 and transmitter TX and a second optional transceiver 154 may be formed from the combination of receiver RX2 and an additional transmitter TX.

[0077] Receivers RX1 and RX2 and transmitter TX may be coupled to baseband processor circuitry 152. Receivers RX1 and RX2 may process radio-frequency signals received from switches 104 and 106 and provide the processed radio-frequency signals to baseband processor circuitry 152. For example, receiver RX1 may receive radio-frequency signals corresponding to LTE band 17 and demodulate the radio-

frequency signals to form baseband signals. In this scenario, the baseband signals may be processed by baseband processor circuitry 152.

[0078] FIG. 7 is a graph showing illustrative bands of radio-frequency signals that may be handled using the circuitry of FIG. 6. In the example of FIG. 7, frequency band LB_{TX} may correspond to a low transmit frequency band such as 704-716 MHz for LTE band 17 and LB_{RX} may correspond to a low receive frequency band such as 734-746 MHz for LTE band 17 (e.g., LB_{TX} may correspond to the transmit band of LTE band 17 and LB_{RX} may correspond to the receive band of LTE band 17). Frequency band HB_{TX} may correspond to a high transmit frequency band such as 1710-1755 MHz for LTE band 4 and HB_{RX} may correspond to a high receive frequency band such as 2110-2155 MHz for LTE band 4 (e.g., HB_{TX} may correspond to the transmit band of LTE band 4 and HB_{RX} may correspond to the receive band of LTE band 4).

[0079] Diplexer 68 may be configured to partition the radio-frequency transmissions into a first signal partition of frequencies below F1 and a second signal partition of frequencies above F1 (e.g., filter FLB may be configured to provide the first signal partition to switch 64LB and filter HLB may be configured to provide the second signal partition to switch 64HB). Switch 64LB may be configured to couple a first duplexer 54 associated with frequency bands LB_{TX} and LB_{RX} to filter FLB. Switch 64HB may be configured to couple a second duplexer 54 associated with frequency bands HB_{TX} and HB_{RX} to filter HLB.

[0080] First duplexer 54 may be configured to isolate low transmit band LB_{TX} from low receive band LB_{RX} (e.g., using filters to isolate frequencies lower than F2 from frequencies higher than F2). Second duplexer 54 may be configured to isolate high transmit band HB_{TX} from high receive band HB_{RX} (e.g., using filters to isolate frequencies lower than F3 from frequencies higher than F3). Low receive band LB_{RX} may be provided to a first receiver RX1 and high receive band HB_{RX} may be provided to a second receiver RX2. In this way, two different frequency bands may be simultaneously received and processed by wireless communications circuitry 34.

[0081] To communicate in a carrier aggregation mode (e.g., to communicate between a cellular base station and a wireless device using simultaneous radio-frequency transmissions in different communications bands), the steps of the illustrative flowchart of FIG. 8 may be performed.

[0082] In step 202, a cellular base station and a wireless electronic device 10 may prepare for carrier aggregation. For example, a base station may prepare for transmission of multiple data streams and instruct the wireless electronic device to prepare for simultaneous receipt of multiple data streams in different communications bands (e.g., the base station may instruct the wireless electronic device to operate in a carrier aggregation mode). The multiple data streams may be generated from dividing a single source data stream into multiple portions. In response to receiving instructions to prepare for simultaneous receipt of multiple data streams, the wireless electronic device may configure switches to make appropriate routing connections (e.g., the switches may be configured to route each communications band to a respective receiver).

[0083] In step 204, the base station may simultaneously transmit multiple data streams on different communications bands to wireless electronic device 10. For example, the base station may transmit a first data stream on LTE band 17 and a second data stream on LTE band 4.

[0084] In step 206, electronic device 10 may use multiplexing circuitry such as diplexer 68 and duplexers 54 to divide radio-frequency signals that are received from the base station based on frequency. For example, electronic device 10 may use a diplexer 68 to divide radio-frequency signals received by an antenna 40C from a base station into relatively low frequencies and relatively high frequencies. The relatively low frequencies may be provided to a first switch 64LB that has been configured (e.g., configured during step 202) to route the relatively low frequencies to a first duplexer 54. The relatively high frequencies may be provided to a second switch 64HB and routed to a second duplexer 54. The first duplexer 54 may isolate a first data stream from the relatively low frequencies and provide the first data stream to receiver RX1. The second duplexer 54 may isolate a second data stream from the relatively high frequencies and provide the second data stream to receiver RX2.

[0085] In step 208, electronic device 10 may simultaneously receive the multiple data streams using multiple receivers. For example, receiver RX1 may demodulate a first data stream and provide the demodulated first data stream to the base station. Receiver RX2 may demodulate a second data stream and provide the demodulated second data stream to the base station.

[0086] In step 210, the base station may simultaneously receive the demodulated first and second data streams and combine the demodulated first and second data streams to reconstruct the single source data stream.

[0087] As an example, a base station may prepare for transmission of a first data stream on LTE band 4 and transmission of a second data stream on LTE band 17. In this scenario, the base station may instruct a wireless electronic device 10 to prepare for simultaneous receipt of the first data stream in LTE band 4 and the second data stream in LTE band 17. In response to the instruction from the base station, wireless electronic device 10 may configure switch 64LB to route low band signals received from diplexer 68 to a first duplexer 54 associated with LTE band 17. Device 10 may configure switch 64HB to route high band signals received from diplexer 68 to a second duplexer 54 that is associated with LTE band 4. First duplexer 54 may provide LTE band 17 signals to receiver RX1 via switch 104. Second duplexer 54 may provide LTE band 4 signals to receiver RX2 via switch 106. Receivers RX1 and RX2 may simultaneously provide the LTE band 17 and LTE band 4 data streams to baseband processor circuitry for processing.

[0088] The foregoing is merely illustrative of the principles of this invention and various modifications can be made by those skilled in the art without departing from the scope and spirit of the invention. The foregoing embodiments may be implemented individually or in any combination.

What is claimed is:

1. A method of receiving radio-frequency transmissions with an electronic device, comprising:
 - with an antenna in the electronic device, receiving at least first and second data streams in at least first and second respective communications bands;
 - with a diplexer, routing the first data stream to a first receiver and routing the second data stream to a second receiver;
 - simultaneously receiving the first data stream using the first receiver and the second data stream using the second receiver; and

- with baseband processor circuitry in the electronic device, combining the first data stream received by the first receiver with the second data stream received by the second receiver.
- 2.** The method defined in claim **1** wherein the diplexer comprises a low pass filter, wherein routing the first data stream to the first receiver comprises:
- with the low pass filter, routing the first data stream to the first receiver and blocking the second data stream from reaching the first receiver.
- 3.** The method defined in claim **1** wherein the diplexer comprises a high pass filter, wherein routing the second data stream to the second receiver comprises:
- with the high pass filter, routing the second data stream to the second receiver and blocking the first data stream from reaching the second receiver.
- 4.** The method defined in claim **1** further comprising:
- with a switching circuit that is interposed between the first receiver and the diplexer, receiving the first data stream; and
- with the switching circuit, routing the first data stream to a duplexers that is associated with the first communications band.
- 5.** The method defined in claim **4** further comprising:
- with the duplexers, routing the first data stream to an additional switching circuit that is interposed between the duplexers and the first receiver.
- 6.** The method defined in claim **5** further comprising:
- configuring the additional switching circuit to route the first data stream to the first receiver.
- 7.** The method defined in claim **1** further comprising:
- with the first receiver, demodulating the first data stream; and
- with the second receiver, demodulating the second data stream.
- 8.** Wireless communications circuitry, comprising:
- a first radio-frequency receiver configured to operate in a first communications band;
- a second radio-frequency receiver configured to operate in a second communications band;
- an antenna configured to receive at least a first data stream in a first communications band and a second data stream in a second communications band;
- a diplexer having a first port that is coupled to the first radio-frequency receiver, a second port that is coupled to the second radio-frequency receiver, and a third port that is coupled to the antenna; and
- baseband circuitry configured to simultaneously receive the first data stream from the first radio-frequency receiver and the second data stream from the second radio-frequency receiver.
- 9.** The wireless circuitry defined in claim **8** wherein the first radio-frequency receiver comprises a Long Term Evolution (LTE) cellular telephone receiver configured to operate in LTE Band **17** and wherein the second radio-frequency receiver includes an LTE cellular telephone receiver configured to operate in LTE band **4**.
- 10.** The wireless circuitry defined in claim **8** wherein the diplexer comprises a low pass filter and a high pass filter.
- 11.** The wireless circuitry defined in claim **10** wherein the low pass filter is configured to pass frequencies associated with the first data stream without passing frequencies associated with the second data stream.
- 12.** The wireless circuitry defined in claim **11** wherein the high pass filter is configured to pass frequencies associated with the second data stream without passing frequencies associated with the first data stream.
- 13.** The wireless circuitry defined in claim **10** further comprising:
- a first duplexers that is interposed between the diplexer and the first radio-frequency receiver and is configured to route the first data stream to the first radio-frequency receiver; and
- a second duplexers that is interposed between the diplexer and the second radio-frequency receiver and is configured to route the second data stream to the second radio-frequency receiver.
- 14.** The wireless circuitry defined in claim **13** further comprising:
- oscillator circuitry coupled to the first receiver and the second receiver that is configured to provide the first receiver with a first signal at a first frequency associated with the first data stream and configured to provide the second receiver with a second signal at a second frequency associated with the second data stream.
- 15.** A method of operating wireless communications circuitry, comprising:
- receiving instructions from a base station that direct the wireless communications circuitry to prepare for simultaneous receipt of a first data stream in a first communications band and a second data stream in a second communications band;
- in response to receiving the instructions from the base station, configuring switching circuitry in the wireless circuitry to form a first signal path and a second signal path;
- with an antenna in the wireless circuitry, receiving the first and second data streams;
- with a diplexer in the wireless circuitry, routing the first data stream through the first signal path and routing the second data stream through the second signal path; and
- simultaneously receiving the first data stream at a first receiver coupled to the first signal path and the second data stream at a second receiver coupled to the second signal path.
- 16.** The method defined in claim **15** wherein receiving instructions from the base station comprises receiving instructions from the base station to operate in a carrier aggregation mode.
- 17.** The method defined in claim **15** wherein the diplexer comprises a low pass filter and wherein routing the first data stream through the first signal path comprises isolating the first data stream from the second data stream with the low pass filter.
- 18.** The method defined in claim **17** wherein the diplexer further comprises a high pass filter and wherein routing the second data stream through the second signal path comprises isolating the second data stream from the first data stream with the high pass filter.

19. The method defined in claim **15** further comprising:
with a first oscillating circuit, providing a first local oscillator signal at a first frequency associated with the first communications band to the first radio-frequency receiver; and
with a second oscillating circuit, providing a second local oscillator signal at a second frequency associated with the second communications band to the second radio-frequency receiver.

20. The method defined in claim **15** further comprising:
with baseband circuitry, receiving the first and second data streams from the first and second radio-frequency receivers; and
combining the first and second data streams to form a single data stream.

* * * * *