

(19) World Intellectual Property Organization
International Bureau



(43) International Publication Date
22 May 2009 (22.05.2009)

PCT

(10) International Publication Number
WO 2009/064361 A1

- (51) International Patent Classification:
F21K 7/00 (2006.01) H01L 33/00 (2006.01)
G09G 3/00 (2006.01) H05B 33/08 (2006.01)
- (21) International Application Number:
PCT/US2008/012538
- (22) International Filing Date:
7 November 2008 (07.11.2008)
- (25) Filing Language: English
- (26) Publication Language: English
- (30) Priority Data:
11/940,437 15 November 2007 (15.11.2007) US
- (71) Applicant (for all designated States except US): CREE, INC. [US/US]; 4600 Silicon Drive, Durham, North Carolina 27703 (US).
- (72) Inventors; and
- (75) Inventors/Applicants (for US only): ROBERTS, John [US/US]; 1061 Plymouth Ave SE, Grand Rapids, Michigan

- 49506-6525 (US). YOU, Chenhua [US/US]; 209 Glebe Way, Cary, North Carolina 27519 (US).
- (74) Agent: MYERS BIGEL SIBLEY & SAJOVEC, P.A.; P.O. Box 37428, Raleigh, North Carolina 27627 (US).
- (81) Designated States (unless otherwise indicated, for every kind of national protection available): AE, AG, AL, AM, AO, AT, AU, AZ, BA, BB, BG, BH, BR, BW, BY, BZ, CA, CH, CN, CO, CR, CU, CZ, DE, DK, DM, DO, DZ, EC, EE, EG, ES, FI, GB, GD, GE, GH, GM, GT, HN, HR, HU, ID, IL, IN, IS, JP, KE, KG, KM, KN, KP, KR, KZ, LA, LC, LK, LR, LS, LT, LU, LY, MA, MD, ME, MG, MK, MN, MW, MX, MY, MZ, NA, NG, NI, NO, NZ, OM, PG, PH, PL, PT, RO, RS, RU, SC, SD, SE, SG, SK, SL, SM, ST, SV, SY, TJ, TM, TN, TR, TT, TZ, UA, UG, US, UZ, VC, VN, ZA, ZM, ZW.
- (84) Designated States (unless otherwise indicated, for every kind of regional protection available): ARIPO (BW, GH, GM, KE, LS, MW, MZ, NA, SD, SL, SZ, TZ, UG, ZM, ZW), Eurasian (AM, AZ, BY, KG, KZ, MD, RU, TJ, TM), European (AT, BE, BG, CH, CY, CZ, DE, DK, EE, ES, FI, FR, GB, GR, HR, HU, IE, IS, IT, LT, LU, LV, MC, MT, NL,

[Continued on next page]

(54) Title: APPARATUS AND METHODS FOR SELECTING LIGHT EMITTERS FOR A TRANSMISSIVE DISPLAY

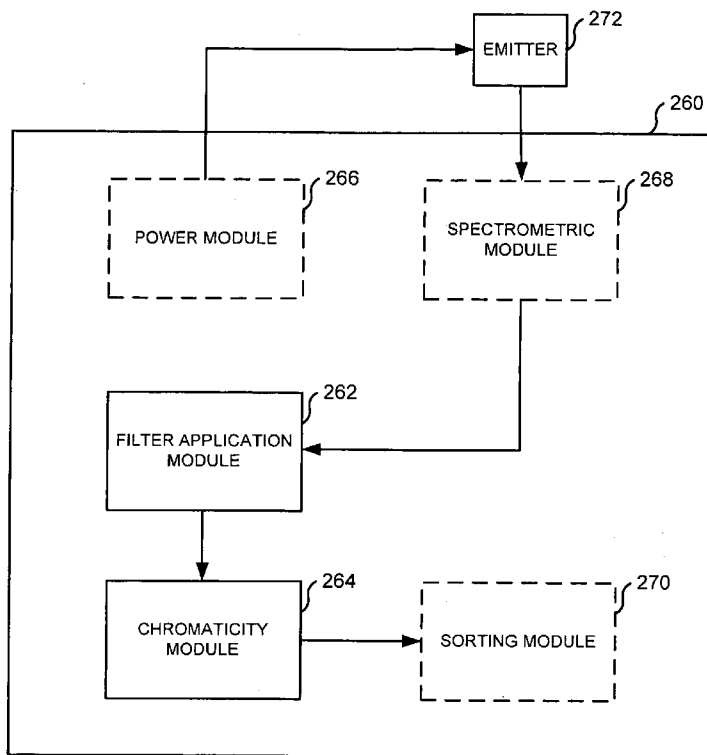

FIGURE 13

(57) Abstract: Provided are devices and methods for providing front-of screen uniformity. Methods include estimating a filter function corresponding to the display and selecting multiple light emitters as a function of characteristics corresponding to light transmitted from the display as determined via the filter function. Devices are provided that include multiple light emitters including a first chromaticity difference corresponding to the multiple light emitters and a second chromaticity difference corresponding to the multiple light emitters and a filter function, wherein the second chromaticity difference is less than the first chromaticity difference.

WO 2009/064361 A1



NO, PL, PT, RO, SE, SI, SK, TR), OAPI (BF, BJ, CF, CG,
CI, CM, GA, GN, GQ, GW, ML, MR, NE, SN, TD, TG).

— *before the expiration of the time limit for amending the
claims and to be republished in the event of receipt of
amendments*

Published:

— *with international search report*

APPARATUS AND METHODS FOR SELECTING LIGHT EMITTERS FOR A TRANSMISSIVE DISPLAY

FIELD OF THE INVENTION

[0001] The present invention relates to lighting, and more particularly to selecting lighting components used in devices.

BACKGROUND

[0002] Panel lighting devices are used for a number of lighting applications. A lighting panel may be used, for example, as a backlighting unit (BLU) for an LCD display. Backlighting units commonly rely on an arrangement of multiple light emitters such as fluorescent tubes and/or light emitting diodes (LED). An important attribute of the multiple light emitters may include uniformity of color and/or luminance in displayed output. Presently, light emitters may be tested and grouped and/or binned according to their respective output and/or performance to improve relative uniformity among multiple light emitters. The grouping may be performed using, for example, chromaticity values, such as the x,y values used in the CIE 1931 color space that was created by the International Commission on Illumination in 1931. In this manner, each light emitter may be characterized by x,y coordinates. Emitters having similar x,y values may be grouped or binned to be used together. However, emitters having similar x,y coordinates and/or luminosity may include significantly different spectral power distributions that may adversely impact uniformity when used in conjunction with other components in a device.

SUMMARY

[0003] Some embodiments of the present invention include methods for A method for controlling light emission characteristics in a display panel including a display and multiple light emitters that are configured to transmit light through the display. In some embodiments, controlling light emission characteristics may include improving uniformity of light transmitted from the display. In some embodiments, other characteristics of the displayed light may be affected via the method, devices, systems and/or computer program products described herein. For example, some embodiments may provide for selecting light emitters to provide for specific chromaticity performance. Some embodiments of these methods may include

selecting the light emitters as a function of characteristics corresponding to light transmitted from the display panel. Some embodiments include estimating a filter function corresponding to the display panel, wherein the function of characteristics corresponding to light transmitted from the display panel partially corresponds to the filter function.

[0004] In some embodiments, selecting the light emitters includes generating emitter spectral power distribution data for each of the light emitters and generating filtered chromaticity data corresponding to each of the light emitters as a function of the emitter spectral power distribution data and the filter function. In some embodiments, generating filtered chromaticity data includes generating filtered spectral power distribution data for each of the light emitters as a function of the emitter spectral power distribution data and the filter function, estimating tristimulus values corresponding to the filtered spectral power distribution data, and calculating the filtered chromaticity data from the tristimulus values.

[0005] In some embodiments, selecting the light emitters further includes establishing a range of filtered chromaticity data and selecting the light emitters within the range of filtered chromaticity data.

[0006] In some embodiments, selecting the plurality of light emitters includes generating filtered chromaticity data corresponding to each of the light emitters, establishing a range of filtered chromaticity data, and selecting the light emitters within the range of filtered chromaticity data. In some embodiments, selecting the light emitters includes applying a standardized filter to a spectroscopic system that is used to generate the filtered chromaticity data.

[0007] In some embodiments, the light emitters include solid state light emitters. In some embodiments, at least two of the solid state light emitters are configured to emit light having substantially different dominant wavelengths. In some embodiments, at least one of the solid state light emitters includes a blue light emitting LED and a fluorescing compound that is configured to modify the wavelength of light emitted from the blue light emitting LED. In some embodiments, the fluorescing compound includes a phosphor.

[0008] Some embodiments of the present invention include an apparatus that is configured to select the light emitters as a function of characteristics corresponding to light transmitted from the display panel. Some embodiments include a computer program product, including a computer readable storage medium

having computer readable program code embodied therein, the computer readable program code being configured to select the light emitters as a function of characteristics corresponding to light transmitted from the display panel.

[0009] Some embodiments of the present invention include devices including multiple light emitters including a first chromaticity difference between the light emitters and a second chromaticity difference corresponding to the light emitters and a filter function, wherein the second chromaticity difference is less than the first chromaticity difference. In some embodiments, the light emitters include white light emitting LED's and/or cold-cathode fluorescent lamps.

[0010] Some embodiments include an optical element that corresponds to the filter function, wherein the optical element is configured to receive light from the light emitters and transmit filtered light corresponding to chromaticity properties of the light emitters and the optical element. Some embodiments include a fixture housing that is configured to support the light emitters in a light fixture, wherein the optical element includes a light fixture diffuser.

[0011] In some embodiments, the first chromaticity difference corresponds to raw photometric characteristics of the light emitters and wherein the second chromaticity difference corresponds to photometric characteristics of the light emitters as emitted from the optical element.

[0012] Some embodiments include a backlight unit housing that is configured to support the light emitters in a configuration to provide backlighting. Some embodiments include a display that is configured to receive light from the light emitters and selectively transmit received light corresponding to a display image, wherein the filter function corresponds to the display.

[0013] Some embodiments of the present invention include methods of increasing display uniformity in a backlit display panel. Such methods may include estimating a filter function of transmissive display components through which backlight emissions are transmitted and estimating filtered chromaticity data, corresponding to the filter function, for multiple light emitters. Methods may include grouping the light emitters according to multiple ranges of the filtered chromaticity data and selecting a portion of the light emitters according to ones of the ranges of the filtered chromaticity data for use in a backlight unit in the backlit display panel.

[0014] In some embodiments, estimating filtered chromaticity data includes applying the filter function to raw spectral data corresponding to the light emitters. In

some embodiments, estimating filtered chromaticity data includes generating spectral data via a filter that corresponds to the filter function. In some embodiments, the portion of light emitters includes a first chromaticity range corresponding to unfiltered chromaticity data and second chromaticity range corresponding to filtered chromaticity data and wherein the first chromaticity range is greater than the second chromaticity range.

[0015] Some embodiments of the present invention include a computer program product, including a computer readable storage medium having computer readable program code embodied therein, the computer readable program code being configured to carry out the method described herein.

[0016] Some embodiments of the present invention include an apparatus for selecting multiple light emitters based on an intended use. Some embodiments of such an apparatus include a filter application module that is configured to apply a filter function to raw spectral data corresponding to each the light emitters and to generate filtered spectral data corresponding to each of the light emitters. Some embodiments may include a chromaticity module that is configured to estimate, using the filtered spectral data, at least one chromaticity value corresponding to each of the light emitters.

[0017] Some embodiments may include a power module that is configured to provide power to each of the light emitters, a spectrometric module that is configured to estimate the raw spectral data corresponding to each of the light emitters and a sorting module that is configured to sort the light emitters into multiple bins corresponding to the at least one chromaticity value.

[0017] Some embodiments of the present invention include methods for controlling characteristics of light emitted through a transmissive panel. Some embodiments of such methods may include selecting multiple light emitters as a function of the transmissive properties of the transmissive panel and a function of the raw spectral properties of the light emitters. In some embodiments, characteristics of light emitted through a transmitted panel may include specific chromaticity characteristics. Some embodiments may provide that specific chromaticity characteristics include a predefined variance in uniformity corresponding to a specific wavelength. Some embodiments may provide that specific chromaticity characteristics include improved uniformity. In some embodiments, characteristics of

light emitted through a transmitted panel may include specific luminosity characteristics.

BRIEF DESCRIPTION OF THE DRAWINGS

[0018] The accompanying drawings, which are included to provide a further understanding of the invention and are incorporated in and constitute a part of this application, illustrate certain embodiment(s) of the invention.

[0019] Figure 1 is a schematic diagram of a side view illustrating a plurality of light emitters configured to transmit light to one or more transmissive components according to some embodiments of the present invention.

[0020] Figures 2A and 2B are color space chromaticity diagrams illustrating a shift in chromaticity resulting from a transmissive component as illustrated in Figure 1 according to some embodiments of the present invention.

[0021] Figure 3 is a color space chromaticity diagram illustrating emitters having same chromaticity coordinates and different spectral content according to some embodiments of the present invention.

[0022] Figures 4A and 4C are spectral power distribution graphs of points illustrated in Figure 3 before and after application a filter function, as illustrated in Figure 4B, according to some embodiments of the present invention.

[0023] Figures 5A and 5B are block diagrams illustrating systems and/or operations for applying a filter function to light emitter chromaticity data according to some embodiments of the present invention.

[0024] Figure 6 is a block diagram illustrating operations for controlling light emission characteristics in a display panel according to some embodiments of the present invention.

[0025] Figure 7 is a block diagram illustrating operations for selecting multiple light emitters according to some embodiments of the present invention.

[0026] Figure 8 is a block diagram illustrating operations for generating filtered chromaticity data according to some embodiments of the present invention.

[0027] Figure 9 is a block diagram illustrating operations for increasing display uniformity according to some embodiments of the present invention.

[0028] Figure 10 is a schematic diagram of a side view of a device according to some embodiments of the present invention.

[0029] Figure 11 is a schematic diagram of a side view of a device according to other embodiments of the present invention.

[0030] Figure 12 is a schematic diagram of a side view of a device according to yet other embodiments of the present invention.

[0031] Figure 13 is a block diagram illustrating an apparatus for selecting light emitters based on intended use according to some embodiments of the present invention.

DETAILED DESCRIPTION OF EMBODIMENTS OF THE INVENTION

[0032] Embodiments of the present invention now will be described more fully hereinafter with reference to the accompanying drawings, in which embodiments of the invention are shown. This invention may, however, be embodied in many different forms and should not be construed as limited to the embodiments set forth herein. Rather, these embodiments are provided so that this disclosure will be thorough and complete, and will fully convey the scope of the invention to those skilled in the art. Like numbers refer to like elements throughout.

[0033] It will be understood that, although the terms first, second, etc. may be used herein to describe various elements, these elements should not be limited by these terms. These terms are only used to distinguish one element from another. For example, a first element could be termed a second element, and, similarly, a second element could be termed a first element, without departing from the scope of the present invention. As used herein, the term "and/or" includes any and all combinations of one or more of the associated listed items.

[0034] It will be understood that when an element such as a layer, region or substrate is referred to as being "on" or extending "onto" another element, it can be directly on or extend directly onto the other element or intervening elements may also be present. In contrast, when an element is referred to as being "directly on" or extending "directly onto" another element, there are no intervening elements present. It will also be understood that when an element is referred to as being "connected" or "coupled" to another element, it can be directly connected or coupled to the other element or intervening elements may be present. In contrast, when an element is referred to as being "directly connected" or "directly coupled" to another element, there are no intervening elements present.

[0035] Relative terms such as "below" or "above" or "upper" or "lower" or "horizontal" or "vertical" may be used herein to describe a relationship of one element, layer or region to another element, layer or region as illustrated in the figures. It will be understood that these terms are intended to encompass different orientations of the device in addition to the orientation depicted in the figures.

[0036] The terminology used herein is for the purpose of describing particular embodiments only and is not intended to be limiting of the invention. As used herein, the singular forms "a", "an" and "the" are intended to include the plural forms as well, unless the context clearly indicates otherwise. It will be further understood that the terms "comprises" "comprising," "includes" and/or "including" when used herein, specify the presence of stated features, integers, steps, operations, elements, and/or components, but do not preclude the presence or addition of one or more other features, integers, steps, operations, elements, components, and/or groups thereof.

[0037] Unless otherwise defined, all terms (including technical and scientific terms) used herein have the same meaning as commonly understood by one of ordinary skill in the art to which this invention belongs. It will be further understood that terms used herein should be interpreted as having a meaning that is consistent with their meaning in the context of this specification and the relevant art and will not be interpreted in an idealized or overly formal sense unless expressly so defined herein.

[0038] The present invention is described below with reference to flowchart illustrations and/or block diagrams of methods, systems and computer program products according to embodiments of the invention. It will be understood that some blocks of the flowchart illustrations and/or block diagrams, and combinations of some blocks in the flowchart illustrations and/or block diagrams, can be implemented by computer program instructions. These computer program instructions may be stored or implemented in a microcontroller, microprocessor, digital signal processor (DSP), field programmable gate array (FPGA), a state machine, programmable logic controller (PLC) or other processing circuit, general purpose computer, special purpose computer, or other programmable data processing apparatus such as to produce a machine, such that the instructions, which execute via the processor of the computer or other programmable data processing apparatus,

create means for implementing the functions/acts specified in the flowchart and/or block diagram block or blocks.

[0039] These computer program instructions may also be stored in a computer readable memory that can direct a computer or other programmable data processing apparatus to function in a particular manner, such that the instructions stored in the computer readable memory produce an article of manufacture including instruction means which implement the function/act specified in the flowchart and/or block diagram block or blocks.

[0040] The computer program instructions may also be loaded onto a computer or other programmable data processing apparatus to cause a series of operational steps to be performed on the computer or other programmable apparatus to produce a computer implemented process such that the instructions which execute on the computer or other programmable apparatus provide steps for implementing the functions/acts specified in the flowchart and/or block diagram block or blocks. It is to be understood that the functions/acts noted in the blocks may occur out of the order noted in the operational illustrations. For example, two blocks shown in succession may in fact be executed substantially concurrently or the blocks may sometimes be executed in the reverse order, depending upon the functionality/acts involved. Although some of the diagrams include arrows on communication paths to show a primary direction of communication, it is to be understood that communication may occur in the opposite direction to the depicted arrows.

[0041] Reference is now made to Figure 1, which is a block diagram of a side view illustrating a plurality of light emitters configured to transmit light to and/or through one or more transmissive components according to some embodiments of the present invention. Multiple light emitters 100 are configured to emit unfiltered light 102 towards one or more transmissive components 120. It will be understood that transmissive components, as described herein, include components that may be partially and/or fully transmissive. Filtered light 122 is emitted from the transmissive components and includes the spectral characteristics of the unfiltered light 102 as modified by a filtering effect of one or more transmissive components 120. In some embodiments, some of the unfiltered light 102 that reaches one or more transmissive components 120 may partially reflect and/or scatter back into the cavity 125. The reflected light may be further reflected back into the transmissive components 120 as

recycled unfiltered light (not shown) and may give rise to additional filtered light 122 from the transmissive components 120.

[0042] Light emitters 100 according to some embodiments may include, for example, cold cathode fluorescent lamps and/or solid state light emitters, such as, for example, white light emitting LED's, among others. In some embodiments, the light emitters 100 may include white LED lamps that include a blue-emitting LED coated with a fluorescing compound that may modify the wavelength of light that is emitted from the blue light emitting LED. In some embodiments, the fluorescing compound may include a wavelength conversion phosphor that converts some of the blue light emitted by the LED into yellow light. The resulting light, which is a combination of blue light and yellow light, may appear white to an observer.

[0043] In some embodiments, light emitters 100 may include an array of solid state lamps such that at least two of the solid state lamps are configured to emit light having substantially different dominant wavelengths. In some embodiments, an array of solid state emitters may include quaternary additive complementary emitter combinations. For example, in some embodiments, an array of solid state lamps may include red, green and blue light emitting devices. When red, green and blue light emitting devices are energized simultaneously, the resulting combined light may appear white, or nearly white, depending on the relative intensities of the red, green and blue sources. In some embodiments, an array of solid state emitters may include binary complementary emitters such as, for example, cyan and orange light emitters.

[0044] The transmissive component 120 may include one or more layers of active and/or passive optically transmissive materials and/or components. For example, an active transmissive component 120 may include an LCD display. LCD displays may include those typically found in LCD televisions, monitors, laptop computers, and/or other electronic devices including cell phones, PDA's, personal media players and/or gaming consoles, among others. In some embodiments, the transmissive component 120 may include passive optical elements including, but not limited to diffusing and/or refracting devices, among others.

[0045] Although discussed in the context of LCD devices, a transmissive component 120 as discussed herein is not so limited. For example, a transmissive component 120 may generally include an array of optical shutters that may be used with a backlight system that impinges light on the display screen. As is well known to those having skill in the art, an LCD display generally includes an array of LCD

devices that act as an array of optical shutters. Transmissive LCD displays employ backlighting using, for example, fluorescent cold cathode tubes, among others, above, beside and sometimes behind the array of LCD devices. A diffusion panel behind the LCD devices can be used to redirect and scatter the light evenly to provide a more uniform display. In some embodiments, a transmissive component 120 may include a color image such as a photograph, artwork, and/or other transmissive static graphic image such as those that may be used in the context of signs, advertisements, and/or vehicular instrument clusters, among others.

[0046] In some embodiments, an LCD display may include groups of pixels used to electronically generate patterns that may be organized into images. A pixel may include a group of multiple subpixels that may each bear a filter and an addressable LCD element that acts as a field-dependent variable density filter. The filters corresponding to each subpixel modify the white light prior to its passage into the LCD element by narrowing the spectral bandwidth of the light. In this manner, white light from a bulk area source may be rendered as discrete addressable, variable grayscale, colored subpixels.

[0047] In applications where more than one light emitter 100 is needed to achieve sufficient luminous flux in a uniformly distributed fashion, light emitters 100 may be characterized according to performance properties and physically sorted into predetermined groups and/or bins. For example, the light emitters 100 may be sorted according to chromaticity and/or luminosity values in order to achieve an acceptable difference among light emitters 100. Although several of the embodiments described herein are presented in the context of chromaticity values, luminosity values are also relevant for the same reasons as the chromaticity values, albeit to a lesser degree. If the light emitters 100 are sorted based on unfiltered light 102 alone, however, a difference of chromaticity and/or luminosity values of the filtered light 122 may be greater than that of a difference of chromaticity and/or luminosity values of the unfiltered light 102 as a result of a convolution filtering effect of the transmissive component 120 on the spectra of the unfiltered light 102. Thus, according to embodiments herein, the light emitters 100 may be sorted, grouped and/or binned according to chromaticity and/or luminosity of filtered light 122. In this regard, the uniformity of the display may be improved by factoring in the effect of the transmissive component 120 in the selection and/or grouping of the light emitters 100.

[0048] As applied herein and, specifically, to chromaticity and/or luminosity, the term "difference" may include a variety of techniques that may be used to describe variation among data values including an arithmetic difference, statistical variance, standard deviation, maximum and/or minimum ranges among others. In some embodiments, a difference may be estimated as the greatest of the differences between each of the chromaticity and/or luminosity coordinates of the multiple emitters and the average of the chromaticity and/or luminosity coordinates of all of the multiple emitters.

[0049] Reference is now made to Figures 2A and 2B, which are color space chromaticity diagrams illustrating a shift in chromaticity resulting from a transmissive component, as illustrated in Figure 1, according to some embodiments of the present invention. The human eye includes receptors corresponding to the three colors red, green and blue. A method for associating three numbers (tristimulus values) with each color is called a color space. A mathematically defined color space known as CIE 1931 color space defines color in terms of chromaticity. Luminance may be represented by Y, which is approximately correlative of the brightness. Chromaticity may be expressed in terms of x,y parameters, which may be computed using the three tristimulus values. The tristimulus values X, Y and Z may roughly correspond to red, green and blue.

[0050] Referring to Figure 2A, a chromaticity diagram 130 includes an outer boundary that is the spectral locus. Chromaticity of emitted light, such as the unfiltered light 102 of Figure 1, may be characterized in terms of an x,y coordinate pair. For example, point P may represent the chromaticity of the unfiltered light 102.

[0051] Referring to Figure 2B, the chromaticity of filtered light 122 of Figure 1 may be different than that of unfiltered light 102 due to a filtering effect of a transmissive component 120. The chromaticity value of filtered light 122 may be characterized in terms of a different coordinate pair, x',y', illustrated as point P'. In this regard, the chromaticity of the filtered light 122 is dependent on both the spectral content of the unfiltered light 102 and the filtering properties of the transmissive component 122. In the context of multiple light emitters, the chromaticity shift corresponding to the filtering effect is unlikely to be uniform, or even similar, among different ones of the light emitters.

[0052] The lack of uniformity in the chromaticity shift may be attributed to the limited information content of the chromaticity x,y values. For example, the

chromaticity x,y values do not provide for distinctions between spectral power distributions among different emitters.

[0053] Reference is now made to Figure 3, which is a color space chromaticity diagram illustrating emitters having same chromaticity coordinates and different spectral content according to some embodiments of the present invention. The chromaticity diagram 130 illustrates a simplistic representation of two light emitters A and B having chromaticity x,y values corresponding to point P. As illustrated, light emitter A may include spectral power distribution bands correlating to chromaticity (color) values A1 and A2, which, when combined, yield chromaticity x,y values corresponding to P. Light emitter B includes spectral distribution bands corresponding to chromaticity values B1 and B2, which, when combined, yield chromaticity x,y values that also correspond to P. Note that emitters A and B have dramatically distinctive spectral content and yet are characterized by the same chromaticity x,y values at point P. Thus, although light emitters A and B are perceived as the same when viewed directly, they include significantly different spectral content.

[0054] The phenomenon illustrated in Figure 3 may be termed as source metamerism. Metamerism describes the circumstance where two color sources having different spectral power distributions appear to be the same color when viewed side by side. The metamerism occurs because each of the three types of human eye receptors responds to the cumulative energy from a broad range of wavelengths. In this regard, many different combinations of light across all wavelengths can produce an equivalent receptor response and the same tristimulus values. Thus, two spectrally different color samples may visually match and be characterized by the same chromaticity values.

[0055] Reference is now made Figures 4A and 4C, which are spectral power distribution graphs of points illustrated in Figure 3 before and after application of a filter function, as illustrated in Figure 4B, according to some embodiments of the present invention. Referring to Figure 4A, as discussed above regarding Figure 3, a light emitter A may include spectral emissions A1 and A2 that occur at substantially different wavelengths. Similarly, light emitter B may include spectral emissions B1 and B2 that occur at substantially different wavelengths from each other and from spectral emissions A1 and A2. In this regard, although light emitters A and B may be

characterized by the same chromaticity x,y values at P, they have distinctly different spectral power distributions.

[0056] Referring to Figure 4B, a transmissive component, such as, for example, an LCD display, may effectively apply a filtering operation that is simply illustrated as a transmittance plot 150 including high transmission portions 152 corresponding to some wavelengths of light and a low transmission portion 154 corresponding to other wavelengths of light. In some embodiments, the LCD display may include an LCD cell, a color filter array, one or more polarizers, and/or other transmissive components, among others. In this regard, as illustrated in Figure 4C, when light emitted from light emitter A is transmitted through the transmissive component, the resulting light is effectively the same in spectral content as the emitted light because the peak of spectral emissions A1 and A2 are coincident with the high transmission portions 152 of the transmittance plot 150.

[0057] In contrast, when light emitted from light emitter B is transmitted through the transmissive component, the peak of spectral emission B1 is coincident with the low transmission portion 154 and the peak of spectral emission B2 is coincident with a high transmission portion 152. The B1 portion is not significantly transmitted so the resulting light includes a different spectral content and thus the chromaticity value shifts. Stated differently, because the peak of spectral emissions of B1 and B2 correspond to low and high transmission portions 154 and 150, the resulting light is different in spectral content than the light emitted from light emitter B. Thus, in this simple example, the difference in the chromaticity values of the unfiltered light from A and B is essentially zero and the difference in the chromaticity values in the filtered light from A and B is not zero and may significantly impact uniformity in applications such as, for example, a display. In this regard, the advantages of grouping light emitters according to chromaticity values that are defined after modification from a transmissive component are realized.

[0058] Reference is now made to Figures 5A and 5B, which are block diagrams illustrating operations for applying a filter function to light emitter chromaticity data according to some embodiments of the present invention. A light emitter 100 may be tested by a spectroscopic system 170 to determine a spectral power distribution. The spectral power distribution may be used to estimate tristimulus values, which may then be used to estimate chromaticity data.

[0059] A spectroscopic system 170 may include a driver 172 that is configured to drive the light emitter 100. Responsive to the driver 172, the light emitter 100 emits unfiltered light 102, which may be received by a receiver 174. The receiver 174 may generate data 174a corresponding to a spectral power distribution of the light emitter 100. In some embodiments, the receiver 174 may be configured to measure the spectral energy at multiple intervals of wavelengths between 380nm and 780nm, which generally define the visible spectrum. In some embodiments, the receiver 174 may provide source values 174a corresponding to the spectral power distribution of the light from the light emitter 100. Although the receiver 174 is generally presented as a unitary component, in some embodiments, the receiver 174 may include components for receiving, processing, storing and/or transmitting spectral power distribution data 174a in raw, intermediate and/or final states.

[0060] A filter function 176 is applied to the spectral power distribution data 174a that is generated by the receiver 174. In some embodiments, the filter function 176 may be a numerical and/or mathematical expression that may be used to define and/or characterize the filtering effects of transmissive devices. For example, the filter function 176 may include filtering effects corresponding to an LCD cell, films such as BEF and/or DBEF, light guide plates (LGP), the color filter array (CFA), polarizers, diffusers and/or other transmissive components that may transmit and/or modify the emitted light. In some embodiments, the filter function 176 may be expressed as spectral transmittance as a discrete function of wavelength and may include multiple values corresponding to a wavelength range from 380nm to 780nm, for example.

[0061] A filter function 176 corresponding to an LCD cell that includes red, green and blue subpixels may be configured to compensate for relative differences in subpixel areas and/or fill factors. For example, a pixel may devote 50% of the pixel area to a green subpixel and 25% of the pixel area to each of the red and blue subpixels. In some embodiments, the subpixel weighting may be accounted for by measuring bulk light transmittance over a broad surface of the LCD cell that includes many pixels. In this manner, the average spectral transmittance of areas of the LCD cell equal or larger than an area of a single pixel may be determined over the range of wavelengths comprising the visible spectrum.

[0062] Application of the filter function 176 may be accomplished by multiplying and/or convolving the source values determined by the receiver 174 with

the filter function 176 to determine a filtered spectral power distribution 176a. In some embodiments, the filtered spectral power distribution may correspond to a front of screen spectral power distribution of the emitter as used in the device corresponding to the filter function 176. The filtered spectral power distribution 176a, as computed from unfiltered spectral power distribution data 174a and from the filter function 176, may be expressed as:

$$Fos \begin{bmatrix} \lambda \\ 380 \end{bmatrix} = S \begin{bmatrix} \lambda \\ 380 \end{bmatrix} \times F \begin{bmatrix} \lambda \\ 380 \end{bmatrix};$$

where Fos is the filtered spectral power distribution 176a that corresponds to, for example, the filtered light at the front of the screen and includes data at intervals of wavelengths from 380nm to 780nm. S is the source spectral power distribution 174a that is received by the receiver and F is the filter function 176 that is applied to the source spectral power distribution.

[0063] The filtered spectral power distribution 176a may be used by a chromaticity value generator 178 to determine filtered chromaticity data corresponding to the light emitter 100 in the context of the transmissive components. The chromaticity data may be estimated by calculating filtered tristimulus values X' , Y' and Z' by substituting the filtered spectral power distribution data (Fos) 176a for the source spectral power distribution (S) 174a into the tristimulus equations. The filtered chromaticity values x',y' may then be calculated from the filtered tristimulus values. In this manner, the chromaticity coordinates x',y' may be determined as a function of the front of screen and/or displayed light characteristics. The chromaticity coordinates x',y' may then be used to select, group and/or bin the light emitters 100 according to the filtered spectral power data.

[0064] Referring to Figure 5B, a spectroscopic system 171 may include a driver 172 that is configured to drive the light emitter 100. Responsive to the driver 172, the light emitter 100 emits unfiltered light 102, which may be received by a filter element 180. In contrast with using a mathematical and/or numerical filter function applied to raw data, some embodiments use a physical filter element 180 that filters the unfiltered light 102. The filter element 180 may include a standardized physical sample and/or standard corresponding to, for example, an LCD display. In this regard, the filter element 180 may be a nominal reference cell that is substantially the same in spectral properties as the LCD cell for which the light emitter 100 is intended to be used. Differences between the filter element 180 and the LCD that the filter

element 180 approximates include packaging and size, among others. For example, in some embodiments, the filter element 180 may be in the range between 25mm and 75mm square or a similarly sized diameter in the case of a circular filter element 180.

[0065] In application, the filter element 180 may be energized to a maximum state of transparency to realize the physical filtering effects of the LCD display. In this manner, the filtered light 182 that represents the convolution of the filter function with the source spectral data may be transmitted as filtered light 182 to the receiver 174.

[0066] The receiver 174 may generate data corresponding to a spectral power distribution of the filtered light 182. In some embodiments, the receiver 174 may be configured to measure the spectral energy at multiple intervals of wavelengths between 380nm and 780nm, which generally define the visible spectrum. In some embodiments, the receiver 174 is configured to provide values corresponding to a spectral power distribution of the filtered light 182. Although the receiver 174 is generally described as a unitary component, in some embodiments, the receiver 174 may include distinct and/or integrated components for receiving, processing, storing and/or transmitting spectral power distribution data in a raw, intermediate and/or final state.

[0067] The filtered spectral power distribution may be used by a chromaticity value generator 178 to determine filtered chromaticity data corresponding to the filtered light emitter 182. The chromaticity data may be estimated by calculating filtered tristimulus values X' , Y' and Z' by substituting the filtered spectral power distribution data (F_{os}) for the source spectral power distribution (S) into known tristimulus equations and then calculating filtered chromaticity values x',y' from the filtered tristimulus values. In this manner, the chromaticity coordinates x',y' may be determined as a function of the front of screen and/or displayed light characteristics. Although discussed in the context of the CIE 1931 standard, the chromaticity data may also be expressed in terms of other color spaces such as, for example, the CIE 1976 L^* , a^* , b^* color space and/or CIE 1976 $u'v'$ color space, among others. The light emitters 100 can then be selected, grouped and/or binned according to the filtered chromaticity values x',y' .

[0068] Reference is now made to Figure 6, which is a block diagram illustrating operations for controlling light emission characteristics in a display panel according to some embodiments of the present invention. In some embodiments,

controlling light emission characteristics may include improving uniformity of light transmitted from the display. In some embodiments, controlling light emission characteristics may include providing specific chromaticity variance and/or non-uniformity other characteristics of the displayed light that may be affected via the methods, apparatus, systems, and/or computer program products described herein. Some embodiments include selecting multiple light emitters as a function of the transmissive properties of a transmissive panel and a function of the raw spectral properties of the light emitters. Some embodiments may optionally provide that a filter function corresponding to a display is estimated (block 210). In some embodiments, estimating a filter function may include measuring the display panel prior to an intended time of use. The filter function may include data corresponding to how a spectral power distribution of received light is modified as the light is transmitted through the display and/or any transmissive components therein. For example, the filter function may include data such as spectral transmittance, among others, corresponding to multiple intervals of wavelengths within the visible spectrum. The display panel may include any combination of a variety of transmissive and/or selectively transmissive components. For example, the display panel may include an LCD cell, a color filter array, a BEF and/or DBEF film, light guide panel (LGP), one or more polarizers and/or other transmissive components among others. In some embodiments, the display may include a liquid crystal module (LCM) and/or a backlight unit (BLU).

[0069] Light emitters are selected as a function of light emitted from the display panel (block 212). In some embodiments, light emitters may be selected based on a filter function corresponding to a display panel. In such embodiments, the spectral data corresponding to unfiltered emitters may also be used in the selection of the light emitters. In some embodiments, selecting the light emitters may include generating filtered chromaticity data corresponding to each of the light emitters. In some embodiments, the filtered chromaticity data may be generated by applying a standardized filter to a spectroscopic system that is used to generate the filtered chromaticity data. In some embodiments, the standardized filter corresponds to the filter function. Selecting the light emitters may also include establishing a range of filtered chromaticity data and selecting the emitters within the range of filtered chromaticity data.

[0070] In some embodiments, the light emitters may include solid state light emitters. Solid state light emitters may include white light emitters such as, for example, blue emitting LED's with a wavelength conversion phosphor coating and/or groups of LED's that are configured to emit light having dominant wavelengths corresponding to red, green, yellow, cyan, orange and/or blue colors. In some embodiments, the light emitters may be cold cathode fluorescent lamps. By selecting the light emitters as a function of light emitted from the display, front-of-screen uniformity may be increased.

[0071] Reference is now made to Figure 7, which is a block diagram illustrating operations for selecting multiple light emitters, as discussed above regarding Figure 6, according to some embodiments of the present invention. Selecting light emitters (block 212) may include generating raw spectral power distribution data corresponding to each light emitter (block 220). The raw chromaticity data may be generated using a spectroscopic device that is configured to drive the light emitter and receive emitted light. The emitted light may be characterized in terms of a spectral power distribution across the visible spectrum, for example.

[0072] After the raw spectral data is generated, filtered chromaticity data may be generated (block 222). Reference is now made to Figure 8, which is a block diagram illustrating operations for generating filtered chromaticity data (block 222), as discussed above regarding Figure 7, according to some embodiments of the present invention. Filtered spectral power distribution data for the light emitters is generated (block 230). In some embodiments, the filtered spectral power distribution data may be generated by convolving and/or multiplying the raw spectral power distribution data with the filter function to numerically estimate the spectral power distribution data corresponding to light transmitted through the filter, display, and/or transmissive components. The filtered spectral power distribution data may be used to estimate filtered light tristimulus values X' , Y' and Z' (block 232). The filtered tristimulus values X' , Y' and Z' may be used to calculate filtered chromaticity data corresponding to the chromaticity of the light transmitted through the filter, display and/or transmissive components (block 234). For example, chromaticity x',y' values may be calculated using the filtered tristimulus values X' , Y' , and Z' . In this manner, the light emitters may be grouped and/or binned according to the properties of the emitters and the filtering characteristics of a device in which they will be used.

[0073] Reference is now made to Figure 9, which is a block diagram illustrating operations for increasing display uniformity according to some embodiments of the present invention. A filter function of at least one transmissive display component is estimated (block 240). In some embodiments, the filter function may be estimated, for example, in terms of multiple intervals of wavelengths across the visible spectrum. For example, the filter function may be expressed as an array corresponding to intervals of wavelengths in the range between 380nm and 780nm. The number of array elements may be varied to provide more or less granularity in the spectral data as needed. For example, in some embodiments, the array may include an element for every 0.5nm step from 380nm to 780nm. In some embodiments, the array may include an element for every 1.0 nm step from 380nm to 780nm.

[0074] Filtered chromaticity data is estimated for each of a plurality of light emitters (block 242). In some embodiments, the filtered chromaticity data may include generating spectral data via a filter that corresponds to the filter function. In some embodiments, the filtered chromaticity data may include numerically and/or mathematically applying the filter function to raw spectral data corresponding to the light emitters.

[0075] The light emitters may be grouped according to the filtered chromaticity data (block 244). For example, light emitters including filtered chromaticity data within defined ranges and/or bins may be grouped together to improve the uniformity of the light transmitted through the display components. A portion of the light emitters corresponding to a group and/or bin are selected for use in a backlight unit in the backlit display panel (block 246). Although presented in the context of a backlight unit, the methods disclosed herein are applicable to edgelit displays and edgelight units used therein.

[0076] Referring back to Figure 1, devices as disclosed herein may include multiple light emitters 100 that include a first chromaticity difference corresponding to the difference in chromaticity of unfiltered light 102 emitted from the multiple light emitters. The multiple light emitters may also include a second chromaticity difference corresponding to the difference in chromaticity of filtered light 122, such that the second chromaticity difference is less than the first chromaticity difference. In some embodiments, devices may include an optical element 120 that corresponds to the filter function and receives the unfiltered light 102. The optical element 120 may also be configured to transmit filtered light 122 corresponding to the

chromaticity and/or spectral properties of the unfiltered light 102 and the optical element.

[0077] Reference is now made to Figure 10, which is a schematic diagram of a side view of a device according to some embodiments of the present invention. The multiple light emitters 100 may be supported by a backlight unit housing 124 and/or components thereof. In some embodiments, the backlight unit housing 124 may include additional optical and non-optical components. For example, the backlight unit housing 124 may include one or more diffusers and/or reflectors and/or structural features for mounting such components.

[0078] Reference is now made to Figure 11, which is a schematic diagram of a side view of a device according to other embodiments of the present invention. Some embodiments may include a fixture housing 128 and/or components thereof that is configured to support the multiple light emitters 100 in a light fixture. In some embodiments, the optical element includes a lighting diffuser 126.

[0079] Reference is now made to Figure 12, which is a schematic diagram of a device according to yet other embodiments of the present invention. Some embodiments include a support/retention structure 129 that is configured to support the multiple light emitters 100 during transportation, storage and/or dispensing. For example, a support/retention structure 129 may include a tape and/or reel configured to receive, support, store, and/or dispense the multiple light emitters 100. In this regard, the multiple light emitters that are selected, grouped and/or binned according to filtered chromaticity may be provided in commercially beneficial packaging. In some embodiments, a support/retention structure 129 may include a rigid and/or flexible printed circuit board (PCB) strip on which multiple light emitters 100 are mounted prior to use.

[0080] Reference is now made to Figure 13, which is a block diagram illustrating an apparatus for selecting light emitters based on intended use according to some embodiments of the present invention. A selecting apparatus 260 includes a filter application module 262 that is configured to apply a filter function to raw spectral data corresponding to each of multiple light emitters. The filter function may correspond to one or more transmissive components through which emitted light may be transmitted. The one or more transmissive components may correspond to an intended use for the light emitters. In this manner, the filter application module 262

may be configured to generate filtered spectral data corresponding to each of the light emitters.

[0081] A selecting apparatus 260 may include a chromaticity module 264 that is configured to estimate chromaticity values corresponding to each of the light emitters. The chromaticity values may be determined using the filtered spectral data that is generated by the filter application module.

[0082] Some embodiments of a selecting apparatus 260 may optionally include a power module 266 that is configured to provide power to each of the light emitters. In some embodiments, the power module may be configured to provide power across a range of power levels.

[0083] A selecting apparatus 260 may optionally include a spectrometric module 268 that is configured to estimate the raw spectral data corresponding to each of the light emitters. The raw spectral data may be used by the filter application module 262 to estimate the filtered spectral data. A selecting apparatus 260 may optionally include a sorting module 270 that is configured to sort the light emitters into multiple bins and/or groups corresponding to chromaticity values that may be generated in the chromaticity module 264.

[0084] In the drawings and specification, there have been disclosed typical embodiments of the invention and, although specific terms are employed, they are used in a generic and descriptive sense only and not for purposes of limitation, the scope of the invention being set forth in the following claims.

That Which is Claimed is:

1. A method for controlling light emission characteristics in a display including a display panel and a plurality of light emitters that are configured to transmit light through the display panel, the method comprising:

selecting the plurality of light emitters as a function of characteristics corresponding to light transmitted from the display panel.

2. The method of Claim 1, further comprising estimating a filter function corresponding to the display panel, wherein the function of characteristics corresponding to light transmitted from the display panel partially corresponds to the filter function.

3. The method of Claim 1, wherein selecting the plurality of light emitters comprises:

generating emitter spectral power distribution data for each of the plurality of light emitters; and

generating filtered chromaticity data corresponding to each of the plurality of light emitters as a function of the emitter spectral power distribution data and the filter function.

4. The method of Claim 3, wherein generating filtered chromaticity data comprises:

generating filtered spectral power distribution data for each of the plurality of light emitters as a function of the emitter spectral power distribution data and the filter function;

estimating a plurality of tristimulus values corresponding to the filtered spectral power distribution data; and

calculating the filtered chromaticity data from the plurality of tristimulus values.

5. The method of Claim 4, wherein selecting the plurality of light emitters further comprises:

establishing a range of filtered chromaticity data; and

selecting the plurality of light emitters within the range of filtered chromaticity data.

6. The method of Claim 1, wherein selecting the plurality of light emitters comprises:

generating filtered chromaticity data corresponding to each of the plurality of light emitters;

establishing a range of filtered chromaticity data; and

selecting the plurality of light emitters within the range of filtered chromaticity data.

7. The method of Claim 1, wherein selecting the plurality of light emitters comprises applying a standardized filter to a spectroscopic system that is used to generate the filtered chromaticity data.

8. The method of Claim 1, wherein the plurality of light emitters comprise a plurality of solid state light emitters.

9. The method of Claim 8, wherein at least two of the plurality of solid state light emitters are configured to emit light having substantially different dominant wavelengths.

10. The method of Claim 1, wherein at least one of the plurality of solid state light emitters comprises:

a blue light emitting LED; and

a fluorescing compound that is configured to modify the wavelength of light emitted from the blue light emitting LED.

11. The method of Claim 10, wherein the fluorescing compound comprises a phosphor.

12. An apparatus that is configured to perform the steps of Claim 1.

13. A computer program product, comprising a computer readable storage medium having computer readable program code embodied therein, the computer readable program code being configured to carry out the method of Claim 1.

14. A device comprising:

a plurality of light emitters comprising a first chromaticity difference between the plurality of light emitters and a second chromaticity difference corresponding to the plurality of light emitters and a filter function, wherein the second chromaticity difference is less than the first chromaticity difference.

15. The device of Claim 14, wherein the plurality of light emitters comprise white light emitting LED's and/or cold-cathode fluorescent lamps.

16. The device of Claim 14, further comprising an optical element that corresponds to the filter function, wherein the optical element is configured to receive light from the plurality of light emitters and transmit filtered light corresponding to chromaticity properties of the plurality of light emitters and the optical element.

17. The device of Claim 16, further comprising a fixture housing that is configured to support the plurality of light emitters in a light fixture, wherein the optical element comprises a light fixture diffuser.

18. The device of Claim 16, wherein the first chromaticity difference corresponds to raw photometric characteristics of the plurality of light emitters and wherein the second chromaticity difference corresponds to photometric characteristics of the plurality of light emitters as emitted through the optical element.

19. The device of Claim 14, further comprising a backlight unit housing that is configured to support the plurality of light emitters in a configuration to provide backlighting.

20. The device of Claim 19, further comprising a display that is configured to receive light from the plurality of light emitters and selectively transmit the

received light corresponding to a display image, wherein the filter function corresponds to the display.

21. A method of increasing display uniformity in a backlit display panel, the method comprising:

estimating a filter function of transmissive display components through which backlight emissions are transmitted;

estimating filtered chromaticity data, corresponding to the filter function, for a plurality of light emitters;

grouping the plurality of light emitters according to a plurality of ranges of the filtered chromaticity data; and

selecting a portion of the light emitters according to ones of the plurality of ranges of the filtered chromaticity data for use in a backlight unit in the backlit display panel.

22. The method of Claim 21, wherein estimating filtered chromaticity data comprises applying the filter function to raw spectral data corresponding to the plurality of light emitters.

23. The method of Claim 21, wherein estimating filtered chromaticity data comprises generating spectral data via a filter that corresponds to the filter function.

24. The method of Claim 21, wherein the portion of light emitters comprise a first chromaticity range corresponding to unfiltered chromaticity data and second chromaticity range corresponding to filtered chromaticity data and wherein the first chromaticity range is greater than the second chromaticity range.

25. A computer program product, comprising a computer readable storage medium having computer readable program code embodied therein, the computer readable program code being configured to carry out the method of Claim 21.

26. An apparatus for selecting a plurality of light emitters based on an intended use, the apparatus comprising:

a filter application module that is configured to apply a filter function to raw spectral data corresponding to each the plurality of light emitters and to generate filtered spectral data corresponding to each of the plurality of light emitters; and

a chromaticity module that is configured to estimate, using the filtered spectral data, at least one chromaticity value corresponding to each of the plurality of light emitters.

27. The apparatus of Claim 26, further comprising:

a power module that is configure to provide power to each of the plurality of light emitters;

a spectrometric module that is configured to estimate the raw spectral data corresponding to each of the plurality of light emitters; and

a sorting module that is configured to sort the plurality of light emitters into a plurality of bins corresponding to the at least one chromaticity value.

28. A method for controlling characteristics of light emitted through a transmissive panel, the method comprising:

selecting a plurality of light emitters as a function of the transmissive properties of the transmissive panel and a function of the raw spectral properties of the plurality of light emitters.

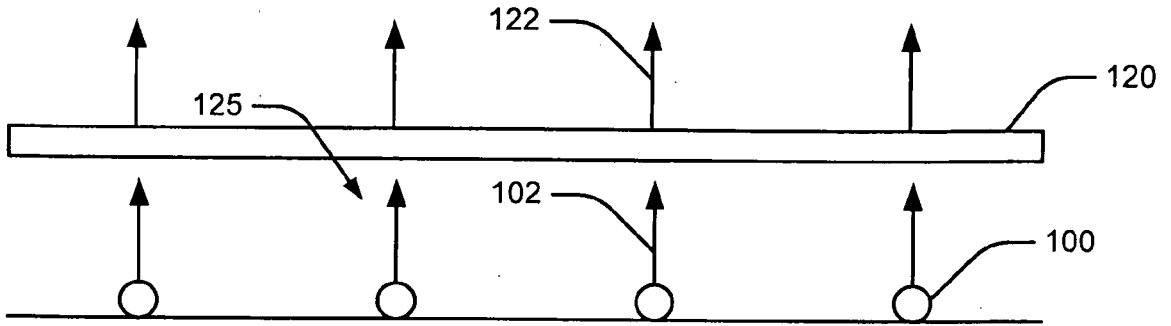

FIGURE 1

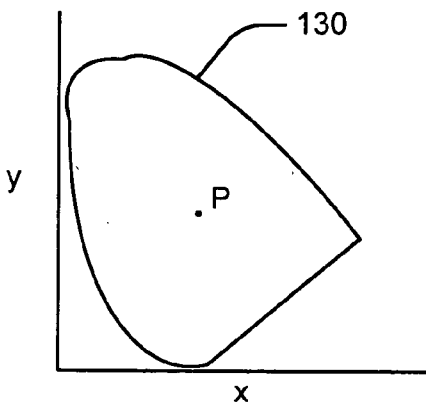

FIGURE 2A

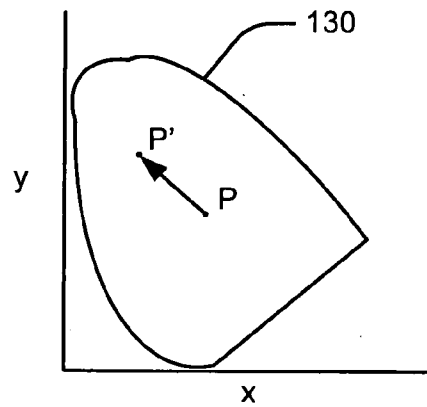

FIGURE 2B

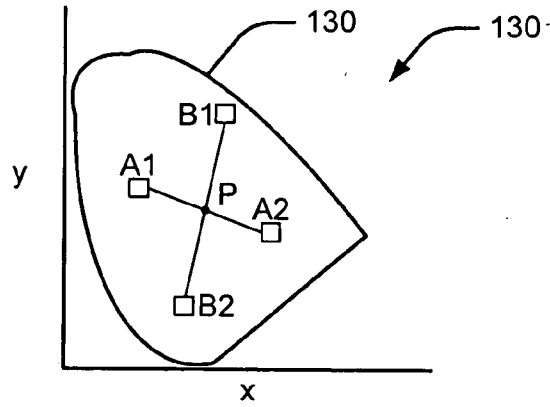

FIGURE 3

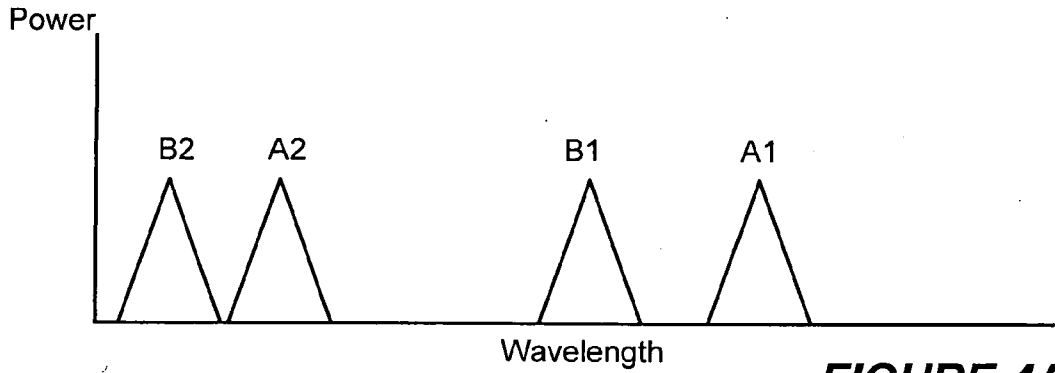

FIGURE 4A

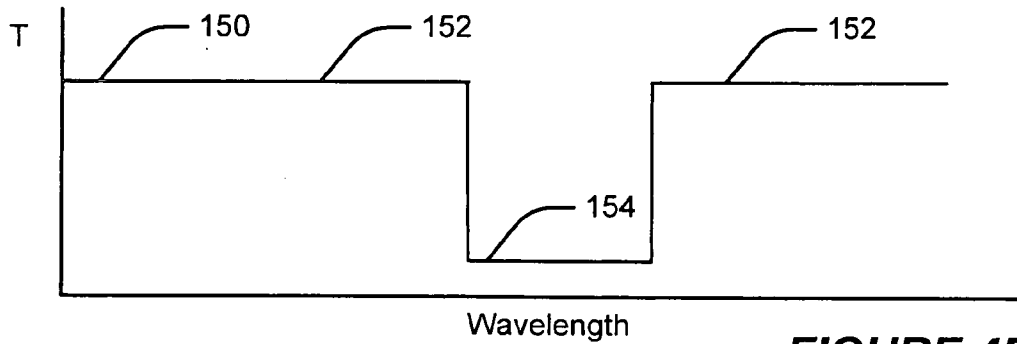

FIGURE 4B

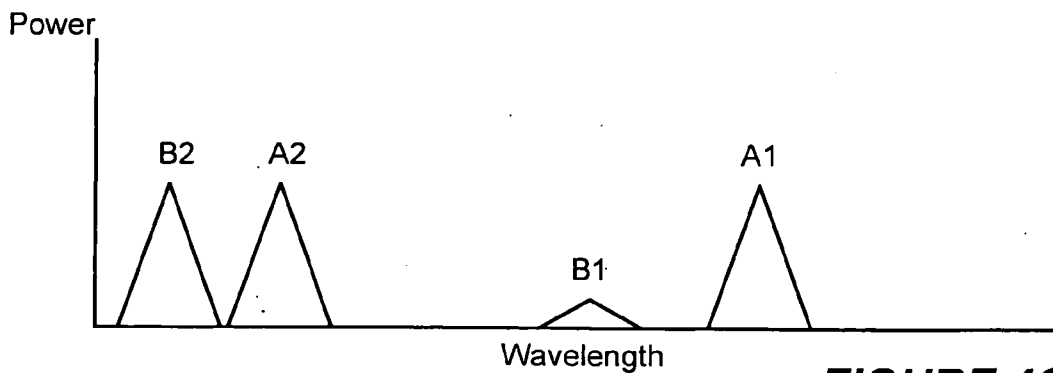

FIGURE 4C

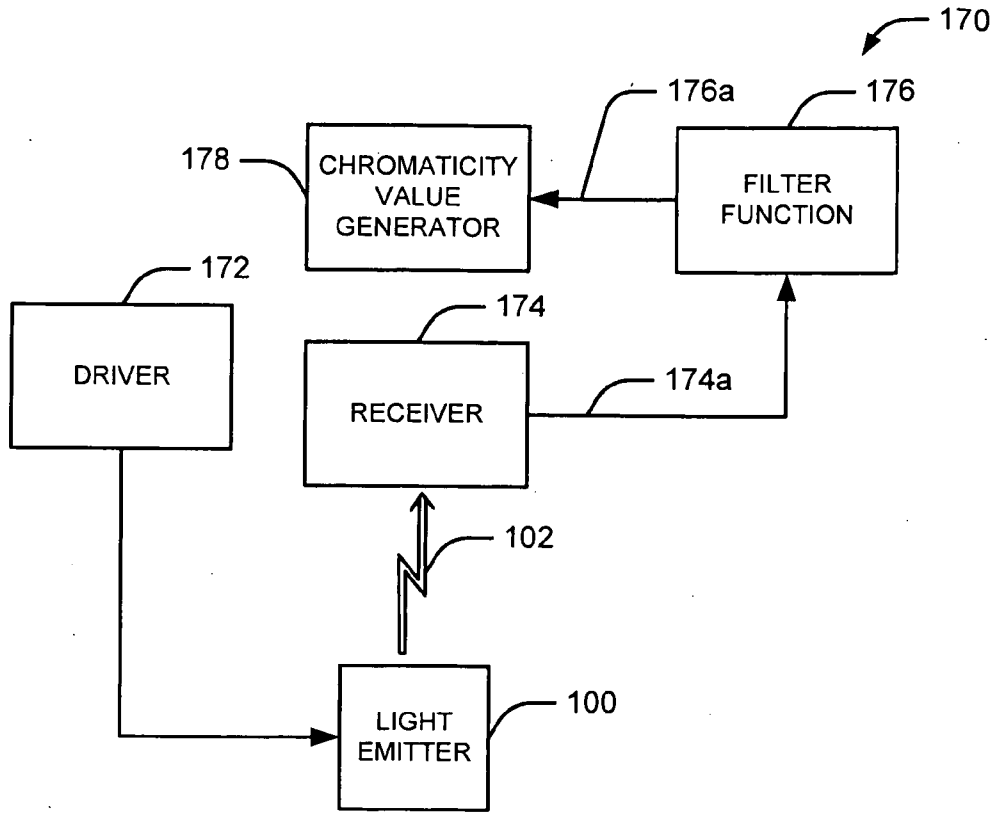

FIGURE 5A

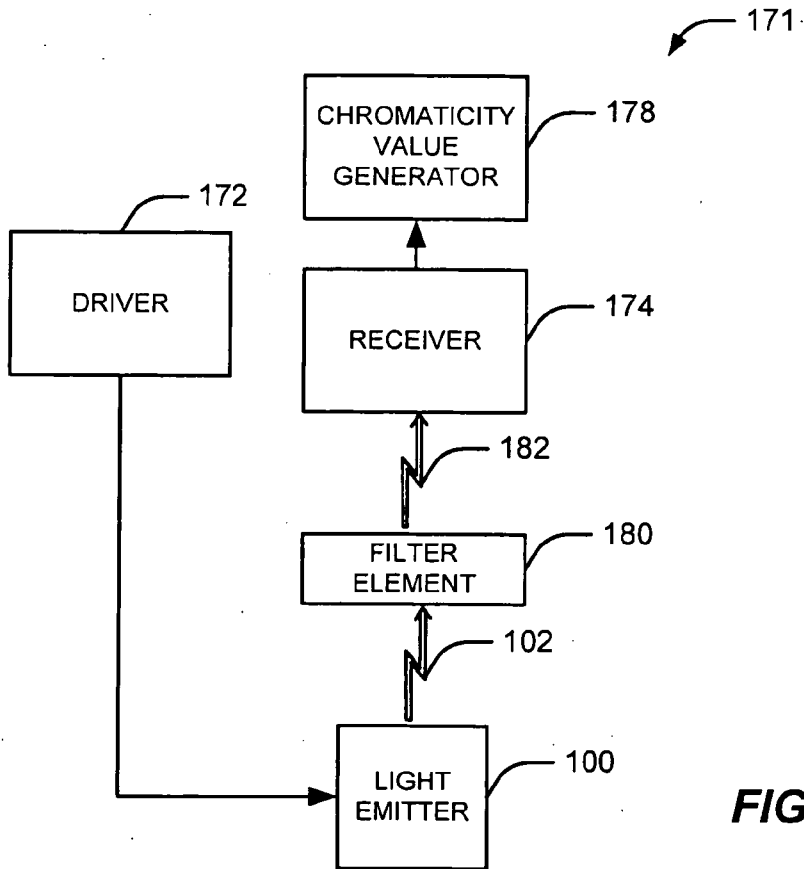

FIGURE 5B

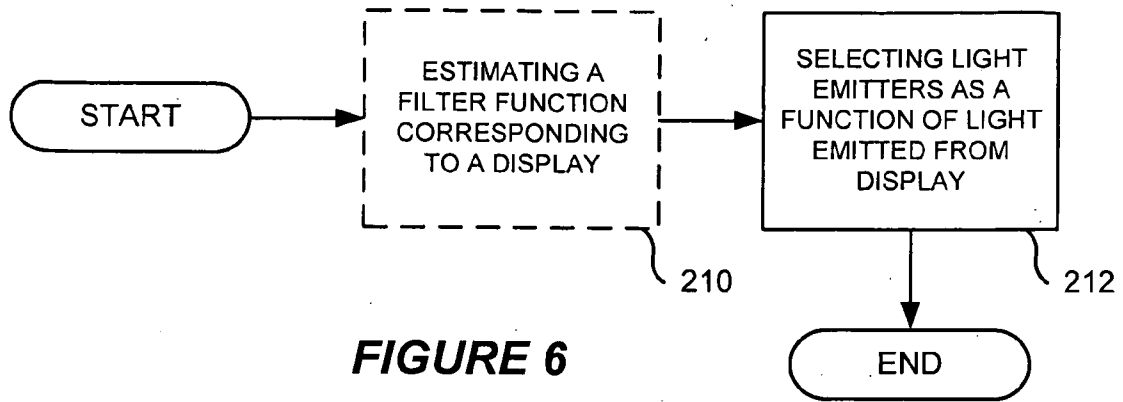

FIGURE 6

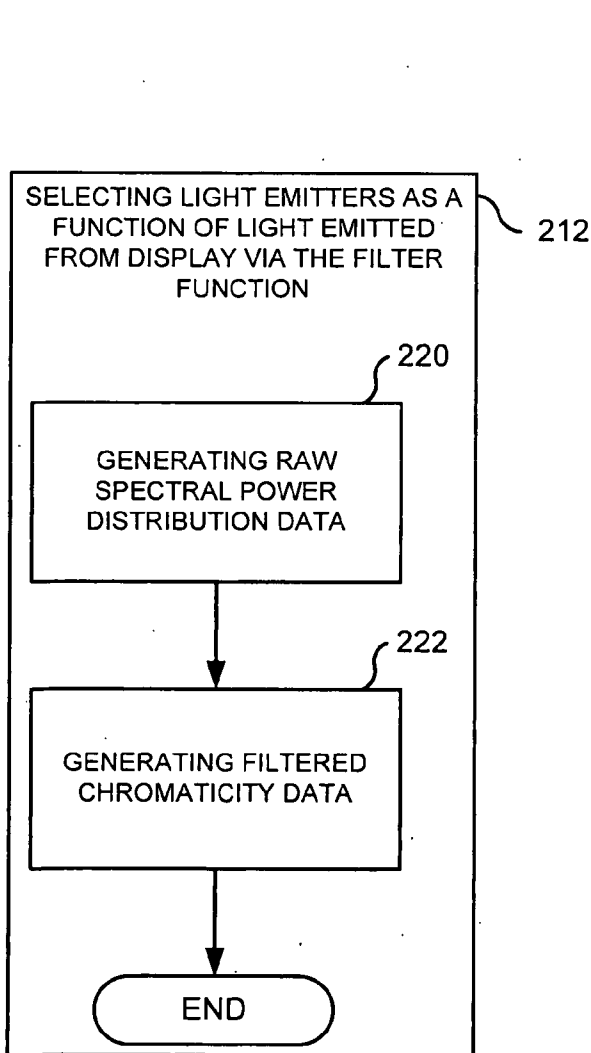

FIGURE 7

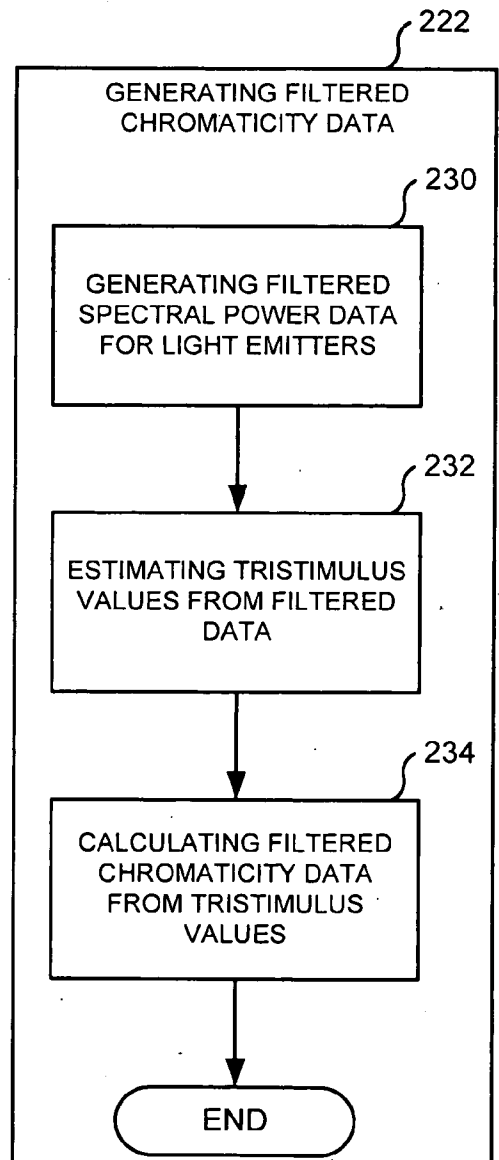

FIGURE 8

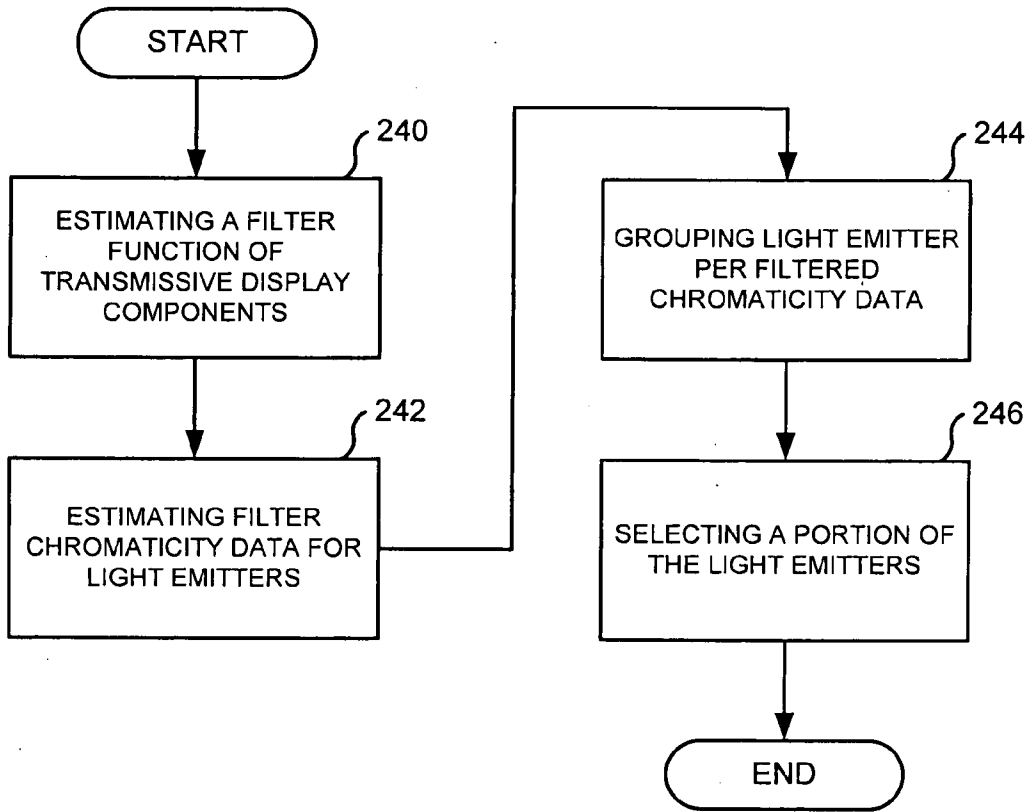
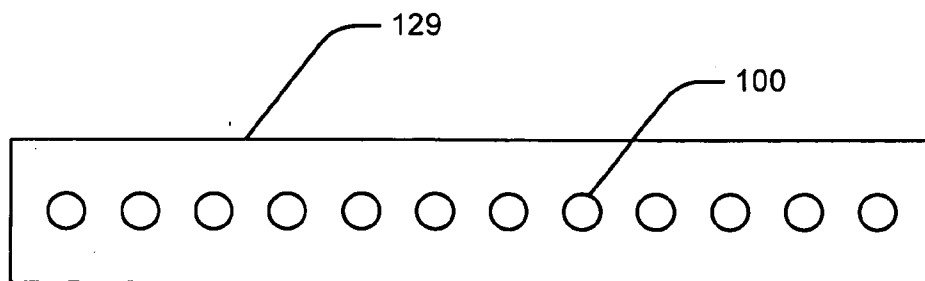
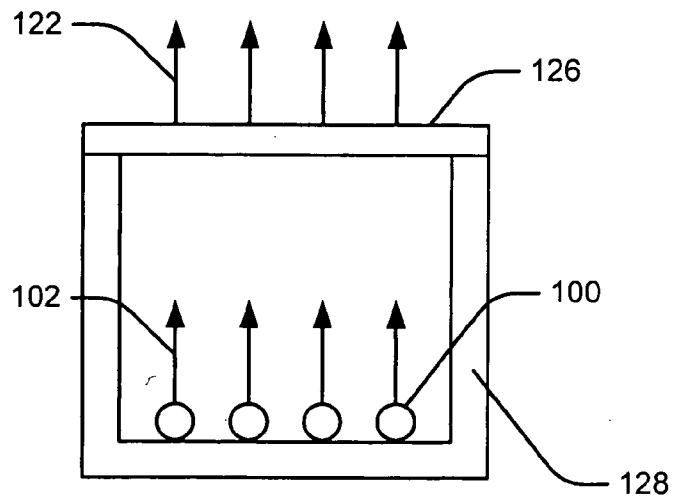
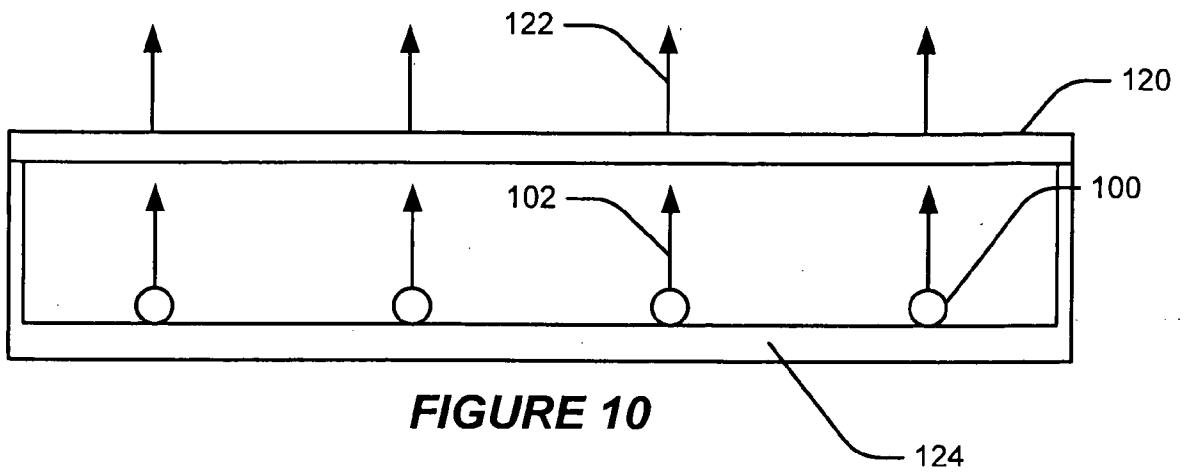

FIGURE 9



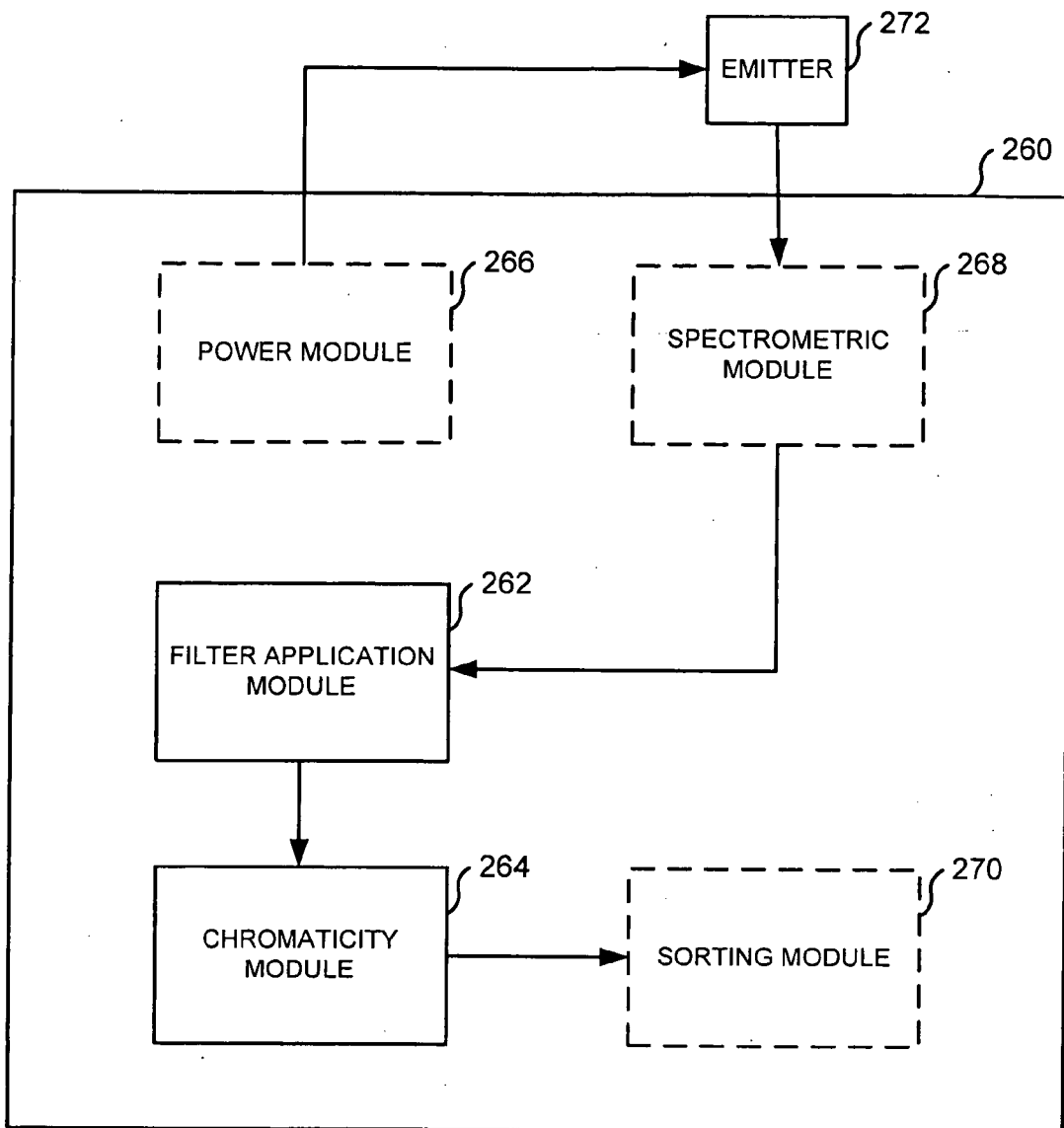

FIGURE 13

INTERNATIONAL SEARCH REPORT

International application No
PCT/US2008/012538

A. CLASSIFICATION OF SUBJECT MATTER

INV. F21K7/00 G09G3/00 H01L33/00 H05B33/08

According to International Patent Classification (IPC) or to both national classification and IPC

B. FIELDS SEARCHED

Minimum documentation searched (classification system followed by classification symbols)
F21K G09G H01L H05B

Documentation searched other than minimum documentation to the extent that such documents are included in the fields searched

Electronic data base consulted during the international search (name of data base and, where practical, search terms used)

EPO-Internal, WPI Data

C. DOCUMENTS CONSIDERED TO BE RELEVANT

Category*	Citation of document, with indication, where appropriate, of the relevant passages	Relevant to claim No.
X	US 2005/259439 A1 (CULL BRIAN D [US] ET AL) 24 November 2005 (2005-11-24) the whole document -----	1,2, 7-20, 26-28
X	US 2007/216704 A1 (ROBERTS JOHN K [US] ET AL) 20 September 2007 (2007-09-20) the whole document -----	1,2, 7-20, 26-28
A	US 6 552 495 B1 (CHANG CHIN [US]) 22 April 2003 (2003-04-22) the whole document -----	1-28
A	US 2005/259423 A1 (HEUSER KARSTEN [DE] ET AL) 24 November 2005 (2005-11-24) abstract; figures -----	1-28
	----- -/--	

Further documents are listed in the continuation of Box C.

See patent family annex.

* Special categories of cited documents :

- *A* document defining the general state of the art which is not considered to be of particular relevance
- *E* earlier document but published on or after the international filing date
- *L* document which may throw doubts on priority claim(s) or which is cited to establish the publication date of another citation or other special reason (as specified)
- *O* document referring to an oral disclosure, use, exhibition or other means
- *P* document published prior to the international filing date but later than the priority date claimed

- *T* later document published after the international filing date or priority date and not in conflict with the application but cited to understand the principle or theory underlying the invention
- *X* document of particular relevance; the claimed invention cannot be considered novel or cannot be considered to involve an inventive step when the document is taken alone
- *Y* document of particular relevance; the claimed invention cannot be considered to involve an inventive step when the document is combined with one or more other such documents, such combination being obvious to a person skilled in the art.
- *&* document member of the same patent family

Date of the actual completion of the international search

16 March 2009

Date of mailing of the international search report

23/03/2009

Name and mailing address of the ISA/

European Patent Office, P.B. 5818 Patentlaan 2
NL - 2280 HV Rijswijk
Tel. (+31-70) 340-2040,
Fax: (+31-70) 340-3016

Authorized officer

Berthommé, Emmanuel

INTERNATIONAL SEARCH REPORT

International application No
PCT/US2008/012538

C(Continuation). DOCUMENTS CONSIDERED TO BE RELEVANT

Category*	Citation of document, with indication, where appropriate, of the relevant passages	Relevant to claim No.
A	WO 2007/060573 A (KONINKL PHILIPS ELECTRONICS NV [NL]; PHILIPS INTELLECTUAL PROPERTY [DE] 31 May 2007 (2007-05-31) the whole document -----	1-28
A	WO 2005/096258 A (KONINKL PHILIPS ELECTRONICS NV [NL]; DEURENBERG PETER H F [NL]; HOELEN) 13 October 2005 (2005-10-13) abstract; figures -----	1-28

INTERNATIONAL SEARCH REPORT

Information on patent family members

International application No PCT/US2008/012538

Patent document cited in search report	Publication date	Publication date	Patent family member(s)	Publication date
US 2005259439	A1	24-11-2005	EP 1749292 A1	07-02-2007
			JP 2008500583 T	10-01-2008
			WO 2005116972 A1	08-12-2005
<hr style="border-top: 1px dashed black;"/>				
US 2007216704	A1	20-09-2007	WO 2008153642 A1	18-12-2008
<hr style="border-top: 1px dashed black;"/>				
US 6552495	B1	22-04-2003	AU 2002351060 A1	30-06-2003
			CN 1633828 A	29-06-2005
			EP 1461982 A1	29-09-2004
			WO 03053111 A1	26-06-2003
			JP 4198599 B2	17-12-2008
			JP 2005513724 T	12-05-2005
<hr style="border-top: 1px dashed black;"/>				
US 2005259423	A1	24-11-2005	NONE	
<hr style="border-top: 1px dashed black;"/>				
WO 2007060573	A	31-05-2007	CN 101313048 A	26-11-2008
			EP 1957607 A1	20-08-2008
			KR 20080072931 A	07-08-2008
			US 2008303407 A1	11-12-2008
<hr style="border-top: 1px dashed black;"/>				
WO 2005096258	A	13-10-2005	NONE	
<hr style="border-top: 1px dashed black;"/>				