

(21) Application No: 0402788.4
(22) Date of Filing: 09.02.2004
(30) Priority Data:
(31) 60450248 (32) 26.02.2003 (33) US
(31) 10605841 (32) 30.10.2003

(51) INT CL⁷:
B60T 8/00
(52) UK CL (Edition W):
F2F FC F647
(56) Documents Cited:
EP 0689116 A EP 0444772 A
EP 0439191 A JP 040325357 A
US 6120113 A US 6053583 A
US 5788345 A US 5719790 A
(58) Field of Search:
UK CL (Edition W) F2F
INT CL⁷ B60T
Other: EPODOC, JAPIO, WPI, TXTUS0, TXTUS1,
TXTUS2, TXTUS3, TXTEP1, TXTGB1, TXTWO1

(71) Applicant(s):
Ford Global Technologies, LLC
(Incorporated in USA - Delaware)
Suite 600, Parklane Towers East,
One Parklane Boulevard, Dearborn,
Michigan 48126, United States of America

(72) Inventor(s):
Jianbo Lu
Todd Allen Brown

(74) Agent and/or Address for Service:
A Messulam & Co. Ltd
43-45 High Road, Bushey Heath, BUSHEY,
Herts, WD23 1EE, United Kingdom

(54) Abstract Title: **A system and method of controlling a safety system of a vehicle**

(57) A control system 24 for controlling a safety system 40 of a vehicle comprises a plurality of wheel speed sensors 30 generating a plurality of wheel velocity signals, a lateral acceleration sensor 32 generating a lateral acceleration signal and a controller 26 coupled to the plurality of wheel speed sensors 30, the lateral acceleration sensor 32 and the safety system 40 wherein the controller 26 is operable to calculate a final reference vehicle velocity in response to a number of inputs including at least the plurality of wheel velocity signals and is further operable to control the safety system 40 in response to the final reference vehicle velocity. The system may further include a steering angle sensor 35, yaw rate sensor 28, while the controller may determine correction factors, and calculate the final reference velocity in response to a learning function.

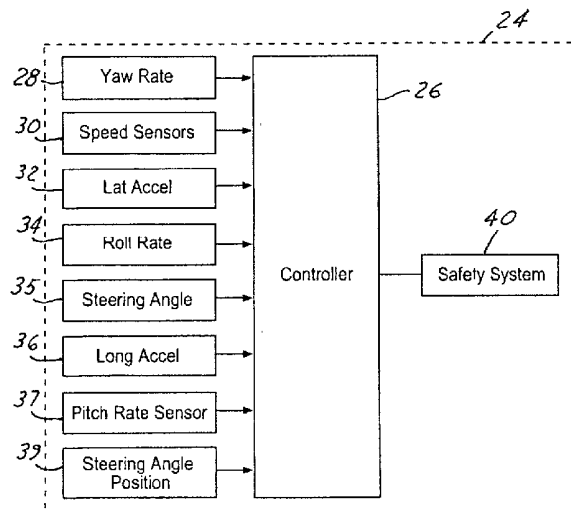

FIG.3

1/2

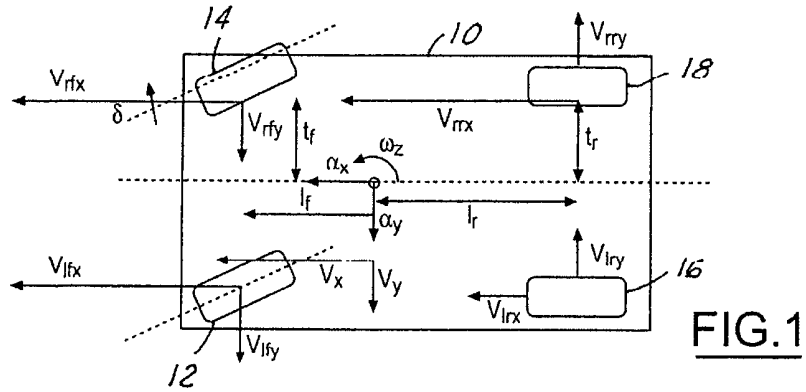

FIG. 1

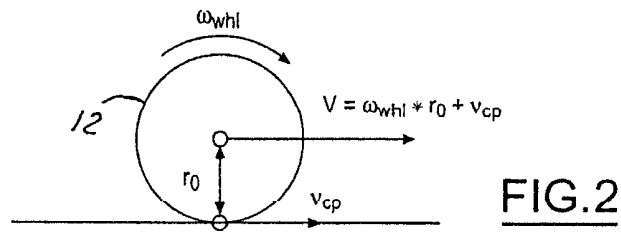

FIG. 2

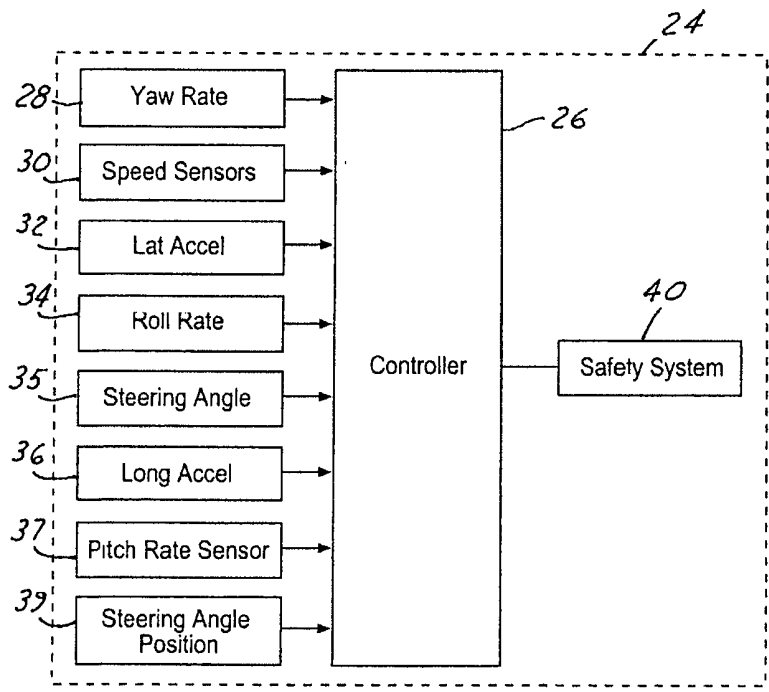

FIG. 3

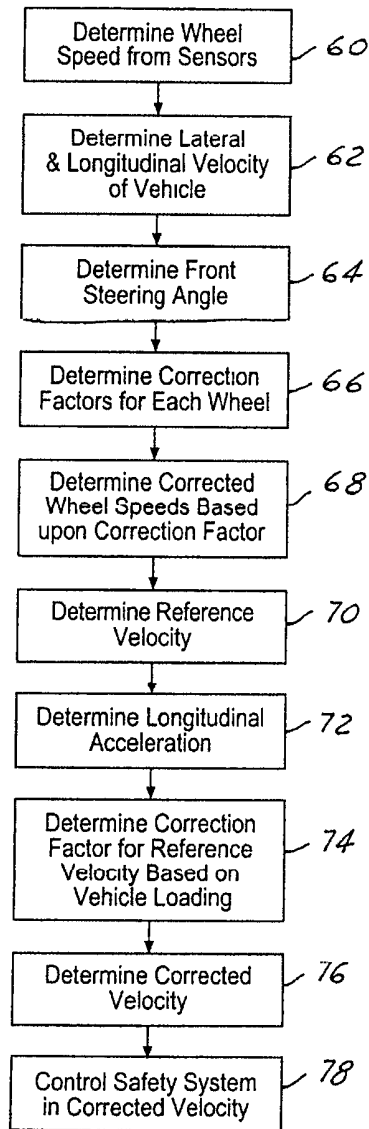

FIG.4

A SYSTEM AND METHOD FOR CONTROLLING A SAFETY SYSTEM

The present invention relates generally to dynamic control systems for automotive vehicles and, more specifically, to a system that compensates wheel speed sensor signals to determine a vehicle reference velocity.

It is a well-known practice to control various operating dynamics of a motor vehicle to achieve active safety. Examples of active safety systems include traction control, yaw stability control and roll stability control systems. A more recent development has been to combine all the available subsystems to achieve better vehicle safety and dynamics performance. The effective operation of the various control systems requires high-accuracy and fast-response-times in the determination of the operating states of the vehicle, regardless of road conditions and driving conditions. Such vehicle operating states include the vehicle longitudinal, lateral and vertical velocities measured along the body-fixed longitudinal, lateral and vertical axes, the attitude of the vehicle body, and the travel course of the vehicle.

One piece of basic information that forms the aforementioned vehicle state estimation is the linear velocity of the rotating centres of the four wheels. For example, this information can be used to assess the wheel slip used in anti-brake-lock controls and traction controls and to estimate the longitudinal velocity of the vehicle. In order to obtain the linear corner velocities, the wheel speed sensors are used. The wheel speed sensors output the products of the wheel rotational speeds and the rolling radii. The wheel rotational speeds are directly measured and the rolling radii are assumed their nominal values. During dynamic manoeuvres, the variations of the wheel normal loading will affect the rolling radii. Hence, the nominal rolling radii may not reflect the actual rolling

radii and thus cause errors in the calculation of the wheel speeds.

It is an object of this invention to provide a system
5 and method to provide a more accurate way in which to determine the vehicle speed taking into consideration changes in rolling radii.

According to a first aspect of the invention there is
10 provided a control system for controlling a safety system of an automotive vehicle comprising a plurality of wheel speed sensors generating a plurality of wheel velocity signals, a lateral acceleration sensor generating a lateral acceleration signal and a controller coupled to the
15 plurality of wheel speed sensors, the lateral acceleration sensor and the safety system wherein the controller is operable to calculate a final reference vehicle velocity in response to a number of inputs including at least the plurality of wheel velocity signals and is further operable
20 to control the safety system in response to the final reference vehicle velocity.

The controller may be further operable to determine a preliminary longitudinal velocity of the vehicle from the
25 plurality of wheel velocity signals, determine a plurality of correction factors for the plurality of wheel velocity signals, determine a vehicle reference velocity in response to the plurality of correction factors, the plurality of wheel velocities and the preliminary longitudinal velocity,
30 determining a vehicle reference velocity correction factor in response to the lateral acceleration, calculate a final reference velocity in response to the velocity correction factor and the vehicle reference velocity and control the safety system in response to the final reference vehicle
35 velocity.

The system may further comprise a steering angle sensor generating a steering actuator angle signal coupled to the controller and a yaw rate sensor generating a yaw rate signal coupled to the controller and the number of inputs further includes the steering angle signal and the yaw rate signal.

The safety system may comprises at least one of a rollover control system, a yaw control system and an antilock brake system.

The final reference vehicle velocity may be further calculated in response to a learning function.

Determining a plurality of correction factors may be performed using a learning function. The learning function may average N correction factors, where N is an integer.

The controller may be further operable to determine a nominal rolling radius. The wheel velocity may be a function of vehicle speed. The nominal rolling radius may be used to calculate a wheel velocity.

According to a second aspect of the invention there is provided a method of controlling a safety system for an automotive vehicle having a plurality of wheels comprising determining a plurality of wheel velocities for the plurality of wheels, determining a preliminary longitudinal velocity of the vehicle from the plurality of wheel velocities, determining a plurality of correction factors for the plurality of wheel velocities for the plurality of wheels, determining a vehicle reference velocity in response to the plurality of correction factors, the plurality of wheel velocities and the preliminary longitudinal velocity, determining a lateral acceleration, determining a vehicle reference velocity correction factor in response to the lateral acceleration, determining a final reference velocity

in response to the vehicle reference velocity correction factor and the vehicle reference velocity and controlling the safety system in response to the final reference velocity.

5

The method may further comprise determining a yaw rate determining a plurality of preliminary lateral velocity of the vehicle from the plurality of wheel speeds and the yaw rate.

10

The method may further comprise determining a front steering angle, wherein determining a plurality of correction factors are determined in response to the front steering angle.

15

According to a second embodiment of the second aspect of the invention there is provided a method of controlling a safety system for an automotive vehicle having a plurality of wheels comprising determining a plurality of wheel velocities for the plurality of wheels, determining a yaw rate, determining a preliminary longitudinal velocity of the vehicle from the plurality of wheel velocities and the yaw rate, determining a front steering angle, determining a plurality of correction factors for the plurality of preliminary wheel speeds in response to the front steering angle, determining a vehicle reference velocity in response to the plurality of correction factors and the plurality of correction factors and the preliminary longitudinal velocity.

25
30

The method may further comprise determining a lateral acceleration, determining a velocity correction factor in response to the lateral acceleration and determining a final reference velocity in response to the velocity correction factor and the vehicle reference velocity.

35

Said safety system may comprises at least one selected from a rollover stability control system, a yaw control system, a traction control system or an antilock brake control system.

5

The method may further comprise using a learning function in the step of determining a plurality of correction factors.

10

The invention will now be described by way of example with reference to the accompanying drawing of which:-

15

Figure 1 is a top view of a motor vehicle illustrating various operating parameters of a vehicle experiencing a turning manoeuvre on a road surface;

Figure 2 is a side view of a motor vehicle wheel illustrating various operating parameters of the wheel;

20

Figure 3 is a block diagram showing a portion of a microprocessor interconnected to sensors and controlled devices, which may be included in a system according to the present invention; and

25

Figure 4 is a control system block diagram in accordance with the present invention.

In the following figures the same reference numerals will be used to illustrate the same components.

30

Referring now to Figure 1, various operating parameters and variables used by the present invention are illustrated as they relate to the application of the present invention to a ground based motor vehicle 10 having wheels 12, 14, 16, 18. Those skilled in the art will immediately recognize the basic physics represented by these illustrations, thereby

making the adaptation to different types of vehicles easily within their reach.

Lateral and longitudinal velocities of the centre of gravity are denoted as V_x and V_y , a yaw angular rate is denoted as ω_z , a front wheel steering angle is denoted as δ , lateral acceleration is represented by a_y , longitudinal acceleration is represented by a_x .

Using those vehicle motion variables, the velocities of the vehicle at the four corner locations, where the wheels are attached to the vehicle, can be calculated in the following form which are projected along the body fixed longitudinal and lateral directions

$$\begin{aligned}
 V_{lfx} &= V_x - \omega_z t_f, & V_{lfy} &= V_y + \omega_z l_f \\
 V_{rfx} &= V_x + \omega_z t_f, & V_{rfy} &= V_y + \omega_z l_f \\
 V_{lrx} &= V_x - \omega_z t_r, & V_{lry} &= V_y - \omega_z l_r \\
 V_{rrx} &= V_x + \omega_z t_r, & V_{rry} &= V_y - \omega_z l_r
 \end{aligned} \tag{1}$$

where t_f and t_r are the half tracks for the front and rear axles, l_f and l_r are the distances between the centre of gravity of the vehicle and the front and rear axles. The variables V_{lf}, V_{rf}, V_{lr} and V_{rr} are the linear velocities of the four corners along the wheel heading directions (left front, right front, left rear and right rear, respectively), which can be calculated as in the following

$$\begin{aligned}
 V_{lf} &= V_{lfx} \cos(\delta) + V_{lfy} \sin(\delta) \\
 V_{rf} &= V_{rfx} \cos(\delta) + V_{rfy} \sin(\delta) \\
 V_{lr} &= V_{lrx} \\
 V_{rr} &= V_{rrx}
 \end{aligned} \tag{2}$$

Referring now to Figure 2, vehicle corner velocity along the wheel longitudinal direction is equal to the sum

of the contact patch slip velocity v_{cp} and the product of the wheel rotational rate ω_{whl} and its rolling radius r_0 .

Referring now to Figure 3, stability control system 24
5 has a controller 26 used for receiving information from a number of sensors which may include a yaw rate sensor 28, speed sensors 30 (at each wheel), a lateral acceleration sensor 32, a roll rate sensor 34, a steering angle (hand wheel position) sensor 35, a longitudinal acceleration
10 sensor 36, a pitch rate sensor 37, and steering angle position sensor 39. Steering angle position sensor 39 senses the position of the steered road wheels. Lateral acceleration, longitudinal acceleration, yaw rate, roll orientation and speed may also be obtained using a global
15 positioning system (GPS). Based upon inputs from the sensors, controller 26 controls the safety system 40. Depending on the desired sensitivity, the type of safety system and various other factors, not all the sensors 28-39 may be used in a commercial embodiment. Other factors may
20 be obtained from the sensors such as the surface mu and the vehicle side slip angle, β .

Roll rate sensor 34 and pitch rate sensor 37 may sense the roll condition to be used with a rollover control system
25 as an extension of the present application.

Safety system 40 may be a number of types of safety systems including a roll stability control system, a yaw control system, antilock brakes, traction control, airbags,
30 or active suspension system.

Safety system 40 if implemented may control a position of a front right wheel actuator, a front left wheel actuator, a rear left wheel actuator, or a right rear wheel
35 actuator. However it will be appreciated that two or more of the actuators may be simultaneously controlled as one actuator.

Based on the inputs from sensors 28 through 39, controller 26 determines the vehicle dynamic conditions and controls the safety system. Controller 26 may also use
5 brake control coupled to front right brakes, front left
brakes, rear left brakes, and right rear brakes to
dynamically control the vehicle. By using brakes in
addition to steering control some control benefits may be
achieved. For example, yaw control and rollover control may
10 be simultaneously accomplished.

Speed sensor 30 may be one of a variety of speed sensors known to those skilled in the art. For example, a suitable speed sensor may include a sensor at every wheel
15 that is averaged by controller 26. As will be described below, the controller 26 translates the wheel speeds into the speed of the vehicle.

Referring now to Figure 4, a method of operating a
20 safety system using a corrected vehicle velocity is determined. In step 60 the wheel speed sensors are read and preferably each wheel has a separate speed sensor.

The wheel speed sensor outputs usually are calibrated
25 for providing the linear directional velocities v_{lf} , v_{rf} , v_{lr} and v_{rr} by multiplying the wheel rotational angular speeds with a nominal rolling radius of the wheels. The variables $\omega_{lf-sensor}$, $\omega_{rf-sensor}$, $\omega_{lr-sensor}$ and $\omega_{rr-sensor}$ are the wheel angular velocity at the left-front corner, right-front corner, left-rear corner and rear-right corner respectively. The nominal
30 rolling radius (typically used in ABS) for calculating wheel speeds from the wheel rotational rates is r_0 .

Thus, the linear directional velocities may be represented by:

$$\begin{aligned}
 v_{lf} &= \omega_{lf-sensor} r_0 \\
 v_{rf} &= \omega_{rf-sensor} r_0 \\
 v_{lr} &= \omega_{lr-sensor} r_0 \\
 v_{rr} &= \omega_{rr-sensor} r_0
 \end{aligned} \tag{3}$$

5

Notice that the wheels have different rolling radii than r_0 . Hence, in order to accurately calculate the actual linear velocities at the four corners, correction factors need to be added. The individual correction factors are denoted as K_{lf} , K_{rf} , K_{lr} and K_{rr} for the left-front, right-front, left-rear and rear-right corners, respectively. Thus, the linear directional velocities may then be represented by:

10

$$\begin{aligned}
 v_{lf} &= K_{lf} \omega_{lf-sensor} r_0 \\
 v_{rf} &= K_{rf} \omega_{rf-sensor} r_0 \\
 v_{lr} &= K_{lr} \omega_{lr-sensor} r_0 \\
 v_{rr} &= K_{rr} \omega_{rr-sensor} r_0
 \end{aligned} \tag{4}$$

15

Notice also that the wheels experience not only the rotational motion but also the linear sliding motion, or longitudinal slip. The slip is caused by the relative motion between the wheel and the road at the contact patch (CP). The longitudinal velocities of the relative motions at the contact patches are denoted as v_{cp-lf} , v_{cp-rf} , v_{cp-lr} and v_{cp-rr} , then the vehicle corner velocities can be expressed as the sums of two speeds as in the following:

20

$$\begin{aligned}
 V_{lf} &= v_{cp-lf} + v_{lf} \\
 V_{rf} &= v_{cp-rf} + v_{rf} \\
 V_{lr} &= v_{cp-lr} + v_{lr} \\
 V_{rr} &= v_{cp-rr} + v_{rr}
 \end{aligned} \tag{5}$$

25

The longitudinal and lateral velocities of the vehicle may be determined in step 62 from the sensors or even a rough estimation by averaging certain variables calculated from wheel speeds.

5

This may be a rough estimate or average but, as mentioned above, does not take into consideration the rolling radius or other factors.

10

Consider

$$V_y = V_x \tan(\beta) \quad (6)$$

where β is the vehicle side slip angle V_y is the lateral velocity of the vehicle and V_x is the longitudinal velocity of the vehicle. In step 64, the front steering angle δ is determined. Then, the individual correction factors K_{lf} , K_{rf} , K_{lr} and K_{rr} for each wheel can be calculated in step 66 as

20

$$\begin{aligned} K_{lf} &= \frac{V_x [\cos(\delta) + \tan(\beta) \sin(\delta)] + \omega_z [l_f \sin(\delta) - t_f \cos(\delta)]}{\omega_{lf-sensor} r_0} - \frac{v_{cp-lf}}{\omega_{lf-sensor} r_0} \\ K_{rf} &= \frac{V_x [\cos(\delta) + \tan(\beta) \sin(\delta)] + \omega_z [l_f \sin(\delta) + t_f \cos(\delta)]}{\omega_{rf-sensor} r_0} - \frac{v_{cp-rf}}{\omega_{rf-sensor} r_0} \\ K_{lr} &= \frac{V_x - \omega_z t_r}{\omega_{lr-sensor} r_0} - \frac{v_{cp-lr}}{\omega_{lr-sensor} r_0} \\ K_{rr} &= \frac{V_x + \omega_z t_r}{\omega_{rr-sensor} r_0} - \frac{v_{cp-rr}}{\omega_{rr-sensor} r_0} \end{aligned} \quad (7)$$

The product term $\tan(\beta)\sin(\delta)$ is negligible in comparison to $\cos(\delta)$, hence equation (7) may be further simplified to the following, which is independent of the vehicle side slip angle β

5

$$\begin{aligned} \kappa_{lf} &\approx \frac{V_x \cos(\delta) + \omega_z [l_f \sin(\delta) - t_f \cos(\delta)]}{\omega_{lf-sensor} r_0} - \frac{v_{cp-lf}}{\omega_{lf-sensor} r_0} \\ \kappa_{rf} &\approx \frac{V_x \cos(\delta) + \omega_z [l_f \sin(\delta) + t_f \cos(\delta)]}{\omega_{rf-sensor} r_0} - \frac{v_{cp-rf}}{\omega_{rf-sensor} r_0} \\ \kappa_{lr} &= \frac{V_x - \omega_z t_r}{\omega_{lr-sensor} r_0} - \frac{v_{cp-lr}}{\omega_{lr-sensor} r_0} \\ \kappa_{rr} &= \frac{V_x + \omega_z t_r}{\omega_{rr-sensor} r_0} - \frac{v_{cp-rr}}{\omega_{rr-sensor} r_0} \end{aligned} \quad (8)$$

In the case of small wheel longitudinal slip ratios, the longitudinal velocities v_{cp-lf} , v_{cp-rf} , v_{cp-lr} and v_{cp-rr} of the relative motions at the contact patches are close to zero, and equation (8) can be further simplified as the following

10

$$\begin{aligned} \kappa_{lf} &\approx \frac{V_x \cos(\delta) + \omega_z [l_f \sin(\delta) - t_f \cos(\delta)]}{\omega_{lf-sensor} r_0} \\ \kappa_{rf} &\approx \frac{V_x \cos(\delta) + \omega_z [l_f \sin(\delta) + t_f \cos(\delta)]}{\omega_{rf-sensor} r_0} \\ \kappa_{lr} &= \frac{V_x - \omega_z t_r}{\omega_{lr-sensor} r_0} \\ \kappa_{rr} &= \frac{V_x + \omega_z t_r}{\omega_{rr-sensor} r_0} \end{aligned} \quad (9)$$

15

The digital value of the above wheel speed individual correction factors κ_{lf} , κ_{rf} , κ_{lr} and κ_{rr} at the time instant $t = k\Delta T$ are κ_{lf_k} , κ_{rf_k} , κ_{lr_k} and κ_{rr_k} , then learning algorithms can be used to calculate the average correction factors.

20

The correction factors are determined using an iterative process that is updated every N calculation samples in the following learning example. Notice that this is a conditional computation which is conducted only if the wheel's longitudinal slip ratios are small.

START

if $k < N$

$$\bar{K}_{lf_{k+1}} = \bar{K}_{lf_k} + \frac{K_{lf_{k+1}}}{N}$$

$$\bar{K}_{rf_{k+1}} = \bar{K}_{rf_k} + \frac{K_{rf_{k+1}}}{N}$$

$$\bar{K}_{lr_{k+1}} = \bar{K}_{lr_k} + \frac{K_{lr_{k+1}}}{N}$$

$$\bar{K}_{rr_{k+1}} = \bar{K}_{rr_k} + \frac{K_{rr_{k+1}}}{N}$$

$k = k + 1$

elseif $k = N$

$k = 0$

$$\bar{K}_{lf} = \bar{K}_{lf_{N+1}}$$

$$\bar{K}_{rf} = \bar{K}_{rf_{N+1}}$$

$$\bar{K}_{lr} = \bar{K}_{lr_{N+1}}$$

$$\bar{K}_{rr} = \bar{K}_{rr_{N+1}}$$

go to *START*

(10)

Using the above learning algorithm, corrected wheel speeds at each wheel can be determined in step 66 based upon the learned correction factor.

$$\hat{v}_{lf_k} = \bar{K}_{lf} r_0 \omega_{lf-sensor_k}$$

$$\hat{v}_{rf_k} = \bar{K}_{rf} r_0 \omega_{rf-sensor_k}$$

$$\hat{v}_{lr_k} = \bar{K}_{lr} r_0 \omega_{lr-sensor_k}$$

$$\hat{v}_{rr_k} = \bar{K}_{rr} r_0 \omega_{rr-sensor_k}$$

(11)

Notice that the above learning algorithm only corrects the individual wheel speeds. There are cases when the

average rolling radii of the four wheels are reduced together due to vehicle loading change. Feeding back the above corrected wheel speeds to the algorithms used in vehicle dynamics control will provide a vehicle reference
 5 velocity \hat{V}_{ref} in step 70 which needs to be further calibrated against the available vehicle longitudinal acceleration sensor signal.

10 Consider that the actual vehicle reference velocity is

$$V_{ref} = \kappa \hat{V}_{ref} \quad (12)$$

where κ is the global correction factor due to the total vehicle loading. κ is usually a slow time varying
 15 parameters

$$\kappa \dot{\hat{V}}_{ref} = a_x - g\theta_y \quad (13)$$

20 where θ_y is the vehicle pitch angle generated from a pitch angle sensor or calculated from the pitch rate sensor signal.

In step 72, the longitudinal acceleration a_x is determined. Then, the following variables are defined

$$\hat{V} = \begin{bmatrix} \hat{v}_{ref_1} \\ \hat{v}_{ref_2} \\ \vdots \\ \hat{v}_{ref_N} \end{bmatrix}, \quad A_x = \begin{bmatrix} a_{x_1} \\ a_{x_2} \\ \vdots \\ a_{x_N} \end{bmatrix}, \quad \Theta_y = \begin{bmatrix} \theta_{y_1} \\ \theta_{y_2} \\ \vdots \\ \theta_{y_N} \end{bmatrix} \quad (14)$$

25

Then a least square computation of the correction factor due to loading can be determined in step 74 as the following:

$$\hat{\kappa} = inv(\hat{V}^T \hat{V}) \hat{V}^T [A_x - g\Theta_y] \quad (15)$$

30

or in the following form

$$\hat{\kappa} = \frac{\sum_{k=M+1}^{M+N} \hat{v}_{ref_k} (a_{x_k} - g\theta_{y_k})}{\sum_{k=M+1}^{M+N} \hat{v}_{ref_k}^2} \quad (16)$$

5 Notice that the global correction factor $\hat{\kappa}$ is updated every N computational samples when the wheels have small longitudinal slip ratios. The digital implementation of equation (16) can be obtained as in the following where V_{k+1} is the updated reference velocity determined in step 76.

10

```

START
if  $k < N$ 
     $A_{k+1} = A_k + \hat{v}_{ref_{k+1}} (a_{x_{k+1}} - g\theta_{y_{k+1}})$ 
     $V_{k+1} = V_k + \hat{v}_{ref_{k+1}} \hat{v}_{ref_{k+1}}$ 
     $k = k + 1$ 
elseif  $k = N$ 
     $\hat{\kappa} = \frac{A_{N+1}}{V_{N+1}}$ 
     $k = 0$ 
go to START
    
```

15 The final corrected wheel speed sensor signals may be corrected by the aforementioned factors can also be obtained as the following:

$$\begin{aligned} \hat{v}_{lf_k} &= \hat{\kappa} \bar{\kappa}_{lf} r_0 \omega_{lf-sensor_k} \\ \hat{v}_{rf_k} &= \hat{\kappa} \bar{\kappa}_{rf} r_0 \omega_{rf-sensor_k} \\ \hat{v}_{lr_k} &= \hat{\kappa} \bar{\kappa}_{lr} r_0 \omega_{lr-sensor_k} \\ \hat{v}_{rr_k} &= \hat{\kappa} \bar{\kappa}_{rr} r_0 \omega_{rr-sensor_k} \end{aligned} \quad (17)$$

Once the corrected final vehicle reference velocity is determined, the safety system 40 may be controlled using the compensated velocity values.

5 Therefore in summary, the present invention provides an improved determination of the individual wheel speeds. In the present invention the individual wheel speed calculations may be compensated for by learning the rolling radii of the wheels. Thus, a more accurate determination of
10 the vehicle reference velocity or the longitudinal velocity may be determined.

In accordance with one aspect of the invention, a control system for controlling a safety system of an
15 automotive vehicle includes a plurality of wheel speed sensors generating a plurality of wheel velocity signals, a steering angle sensor generating a steering actuator angle signal, a yaw rate sensor generating a yaw rate signal, a lateral acceleration sensor generating a lateral
20 acceleration signal and a controller. The controller generates a final reference vehicle velocity in response to the plurality of wheel speed signals, the steering angle signal, the yaw rate signal and the lateral acceleration signal. The controller controls the safety system in
25 response to the final reference vehicle velocity.

In a further aspect of the invention, a method of controlling a safety system for an automotive vehicle having a plurality of wheels includes determining a plurality of
30 wheel velocities for the plurality of wheels, determining a preliminary longitudinal velocity of the vehicle from the plurality of wheel velocities, determining a plurality of correction factors for the plurality of wheel velocities for the plurality of wheels, determining a vehicle reference
35 velocity in response to the plurality of correction factors, the plurality of wheel velocities and the preliminary longitudinal velocity, determining a lateral acceleration,

determining a vehicle reference velocity correction factor
in response to the lateral acceleration, determining a final
reference velocity in response to the vehicle reference
velocity correction factor and the vehicle reference
5 velocity, and controlling the safety system in response to
the final reference velocity.

While particular embodiments of the invention have been
shown and described, it will be appreciated by those skilled
10 in the art that numerous variations and alternate
embodiments could be made without departing from the scope
of the invention.

Claims

1. A control system for controlling a safety system of an automotive vehicle comprising a plurality of wheel speed sensors generating a plurality of wheel velocity signals, a lateral acceleration sensor generating a lateral acceleration signal and a controller coupled to the plurality of wheel speed sensors, the lateral acceleration sensor and the safety system wherein the controller is operable to calculate a final reference vehicle velocity in response to a number of inputs including at least the plurality of wheel velocity signals and is further operable to control the safety system in response to the final reference vehicle velocity.

15

2. A control system as claimed in claim 1 wherein the controller is further operable to determine a preliminary longitudinal velocity of the vehicle from the plurality of wheel velocity signals, determine a plurality of correction factors for the plurality of wheel velocity signals, determine a vehicle reference velocity in response to the plurality of correction factors, the plurality of wheel velocities and the preliminary longitudinal velocity, determining a vehicle reference velocity correction factor in response to the lateral acceleration, calculate a final reference velocity in response to the velocity correction factor and the vehicle reference velocity and control the safety system in response to the final reference vehicle velocity.

20
25
30

3. A control system as claimed in claim 1 wherein the system further comprises a steering angle sensor generating a steering actuator angle signal coupled to the controller and a yaw rate sensor generating a yaw rate signal coupled to the controller and the number of inputs further includes the steering angle signal and the yaw rate signal.

35

4. A control system as claimed in any of claims 1 to 3 wherein the safety system comprises one of a rollover control system, a yaw control system and an antilock brake system.

5

5. A control system as claimed in any of claims 1 to 4 wherein the final reference vehicle velocity is further calculated in response to a learning function.

10

6. A control system as claimed in claim 5 when dependent upon claim 2 wherein determining a plurality of correction factors is performed using a learning function.

15

7. A control system as claimed in claim 6 wherein the learning function averages N correction factors, where N is an integer.

20

8. A control system as claimed in any of claims 1 to 7 wherein the controller is further operable to determine a nominal rolling radius and the wheel velocity is a function of vehicle speed.

25

9. A method of controlling a safety system for an automotive vehicle having a plurality of wheels comprising determining a plurality of wheel velocities for the plurality of wheels, determining a preliminary longitudinal velocity of the vehicle from the plurality of wheel velocities, determining a plurality of correction factors for the plurality of wheel velocities for the plurality of wheels, determining a vehicle reference velocity in response to the plurality of correction factors, the plurality of wheel velocities and the preliminary longitudinal velocity, determining a lateral acceleration, determining a vehicle reference velocity correction factor in response to the lateral acceleration, determining a final reference velocity in response to the vehicle reference velocity correction factor and the vehicle reference velocity and controlling

30

35

the safety system in response to the final reference velocity.

10. A method as claimed in claim 9 wherein the method
5 further comprises determining a yaw rate determining a plurality of preliminary lateral velocity of the vehicle from the plurality of wheel speeds and the yaw rate.

11. A method as claimed in claim 9 or in claim 10
10 where the method further comprises determining a front steering angle, wherein determining a plurality of correction factors are determined in response to the front steering angle.

12. A method of controlling a safety system for an
15 automotive vehicle having a plurality of wheels comprising determining a plurality of wheel velocities for the plurality of wheels, determining a yaw rate, determining a preliminary longitudinal velocity of the vehicle from the
20 plurality of wheel velocities and the yaw rate, determining a front steering angle, determining a plurality of correction factors for the plurality of preliminary wheel speeds in response to the front steering angle, determining a vehicle reference velocity in response to the plurality of
25 correction factors and the plurality of correction factors and the preliminary longitudinal velocity.

13. A method as claimed in claim 11 further comprising
determining a lateral acceleration, determining a velocity
30 correction factor in response to the lateral acceleration and determining a final reference velocity in response to the velocity correction factor and the vehicle reference velocity.

14. A method as claimed in any of claims 9 to 13
35 wherein said safety system comprises at least one selected from a rollover stability control system, a yaw control

system, a traction control system or an antilock brake control system.

15. A method as claimed in any of claims 9 to 14
5 further comprising using a learning function in the step of determining a plurality of correction factors.

16. A system substantially as described herein with reference to the accompanying drawing.

10

17. A system substantially as described herein with reference to the accompanying drawing.



Application No: GB0402788.4
Claims searched: 1-11

Examiner: Mr Nithi Nithiananthan
Date of search: 23 June 2004

Patents Act 1977: Search Report under Section 17

Documents considered to be relevant:

Category	Relevant to claims	Identity of document and passage or figure of particular reference
X	1 at least	EP0439191 A (Mitsubishi); see esp. abstract
X	1 at least	EP0444772 A (Mitsubishi); see esp. abstract
X	1 at least	US5788345 A (Aisin); see esp. abstract
X	1 at least	US5719790 A (Siemens); see esp. abstract
X	1 at least	US6053583 A (Mazda); Vref calculated based on wheel speeds
X	1 at least	JP04325357 A (Toyota); see abstract
X	1 at least	EP0689116 A (GM Corp.); see abstract
X	1 at least	US6120113 A (Aisin); mention of wheel speed sensors and lateral acceleration sensor

Categories:

X	Document indicating lack of novelty or inventive step	A	Document indicating technological background and/or state of the art.
Y	Document indicating lack of inventive step if combined with one or more other documents of same category	P	Document published on or after the declared priority date but before the filing date of this invention
&	Member of the same patent family	E	Patent document published on or after, but with priority date earlier than, the filing date of this application

Field of Search:

Search of GB, EP, WO & US patent documents classified in the following areas of the UKC^W :



INVESTOR IN PEOPLE

22

F2F

Worldwide search of patent documents classified in the following areas of the IPC⁰⁷

B60T

The following online and other databases have been used in the preparation of this search report

EPODOC, JAPIO, WPI, TXTUS0, TXTUS1, TXTUS2, TXTUS3, TXTEP1, TXTGB1, TXTWO1