

(21) Application No: **2116887.7**
 (22) Date of Filing: **24.11.2021**
 (30) Priority Data:
 (31) **202110256522** (32) **09.03.2021** (33) **CN**

(51) INT CL:
A47L 9/04 (2006.01) **A47L 11/40** (2006.01)

(56) Documents Cited:
GB 2163640 A **CN 113229742 A**
US 20210204684 A1

(71) Applicant(s):
Candy Hoover (Suzhou) Co. Ltd.
(Incorporated in China)
5th Floor, No. 288 Dongping Street,
Suzhou Industrial Park, Suzhou City 215123, Jiangsu,
China

(58) Field of Search:
 INT CL **A47L**
 Other: **WPI, EPODOC**

(72) Inventor(s):
Scott Crichton
Cang Hai Guo
Wei Zhuang
Shuai Yu

(74) Agent and/or Address for Service:
Murgitroyd & Company
Murgitroyd House, 165-169 Scotland Street,
GLASGOW, G5 8PL, United Kingdom

(54) Title of the Invention: **Floor cleaning head**
 Abstract Title: **A head for a vacuum cleaner with an agitator and a liquid releasing roller**

(57) A floor cleaning head 13 for a vacuum cleaner comprises a housing 22 having an elongate suction mouth on its underside 15, an elongate rotatable agitator roller 16 mounted in the suction mouth and a means for rotating the agitator roller to sweep, beat or abrade a floor surface. A detachable elongate floor cleaning roller (30, fig. 7) is mounted axially in a cavity 56 which extends parallel with the suction mouth. The floor cleaning roller comprises a tubular core (34, fig. 11) forming a dispensing container and a surrounding sleeve (33, fig. 11) of an absorbent material configured to wipe the floor surface during cleaning. A clip (32, fig. 11) may be provided for rotatably engaging one end of the floor cleaning roller and for detachably securing it to the housing. In use, the head enables floors to be swept by the agitator and simultaneously washed, wiped or dried by the floor cleaning roller.

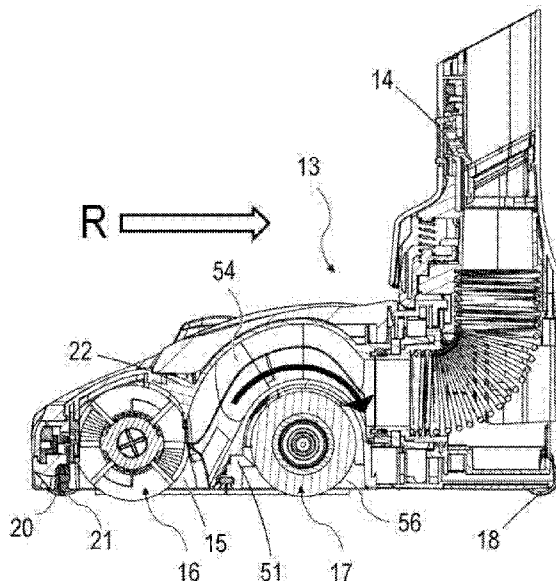

Figure 3

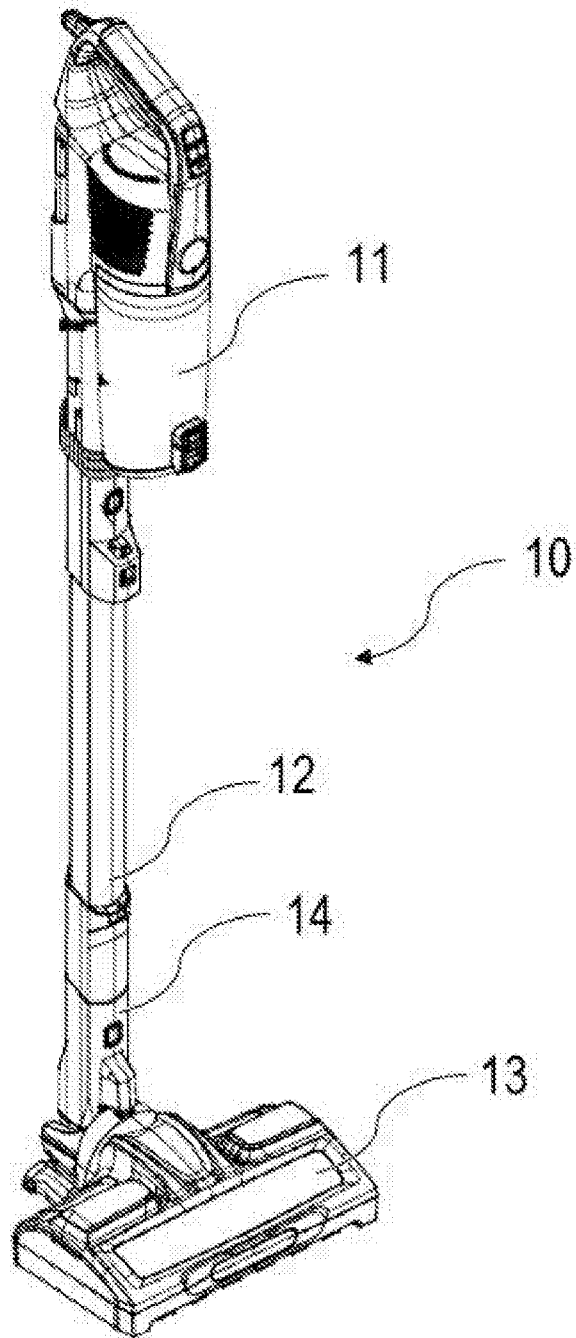

Figure 1

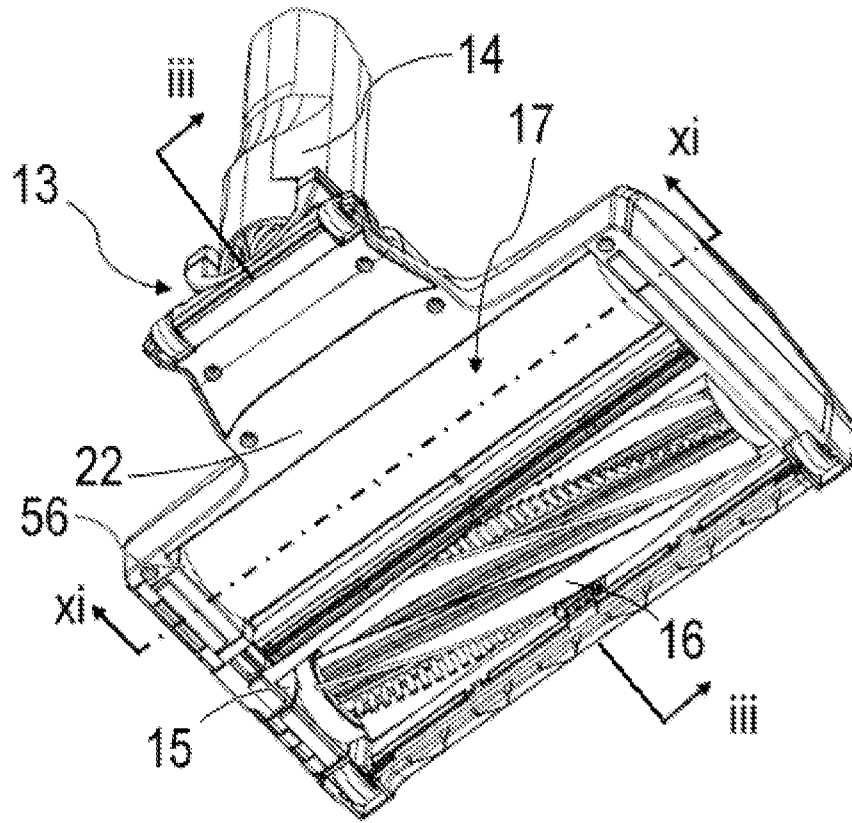

Figure 2

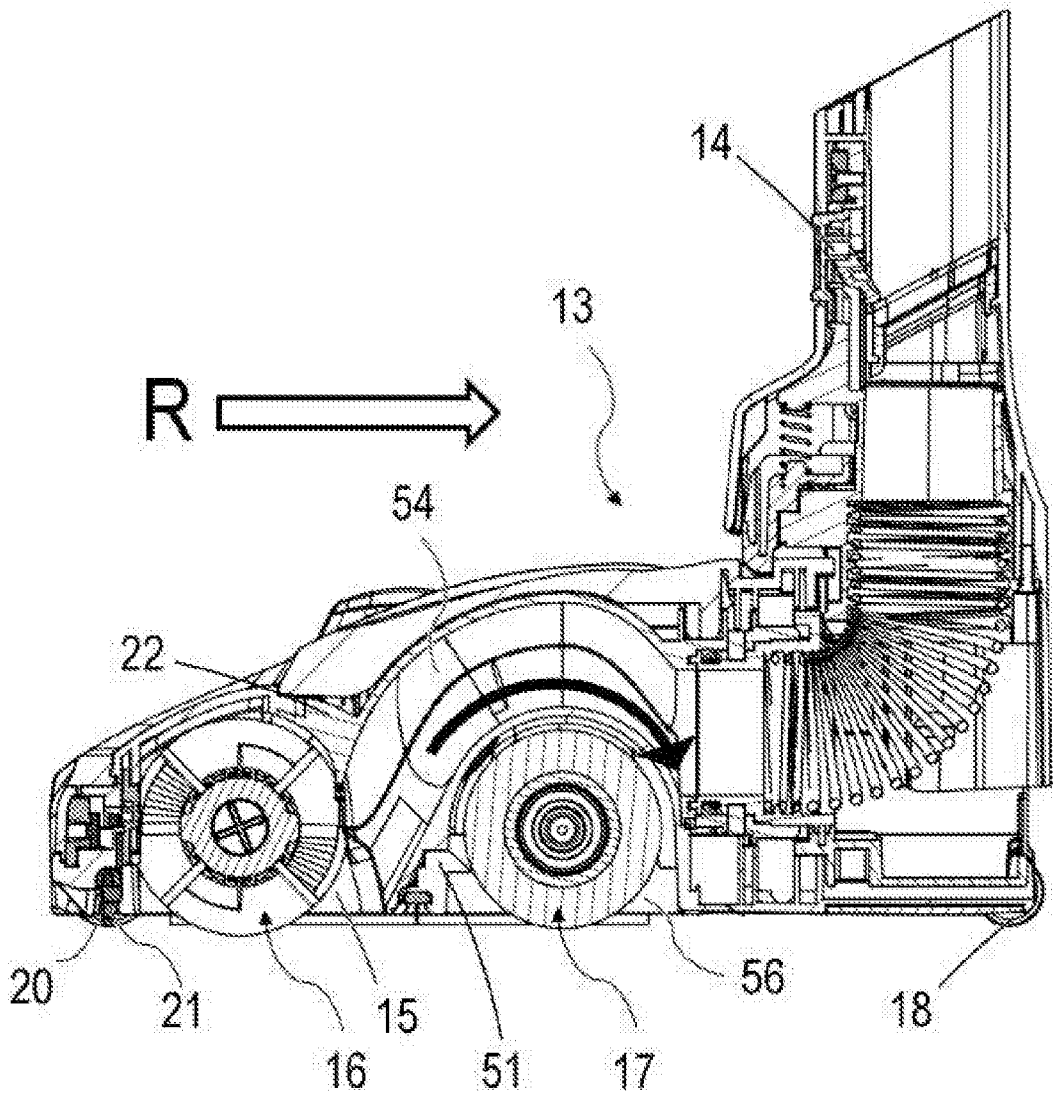

Figure 3

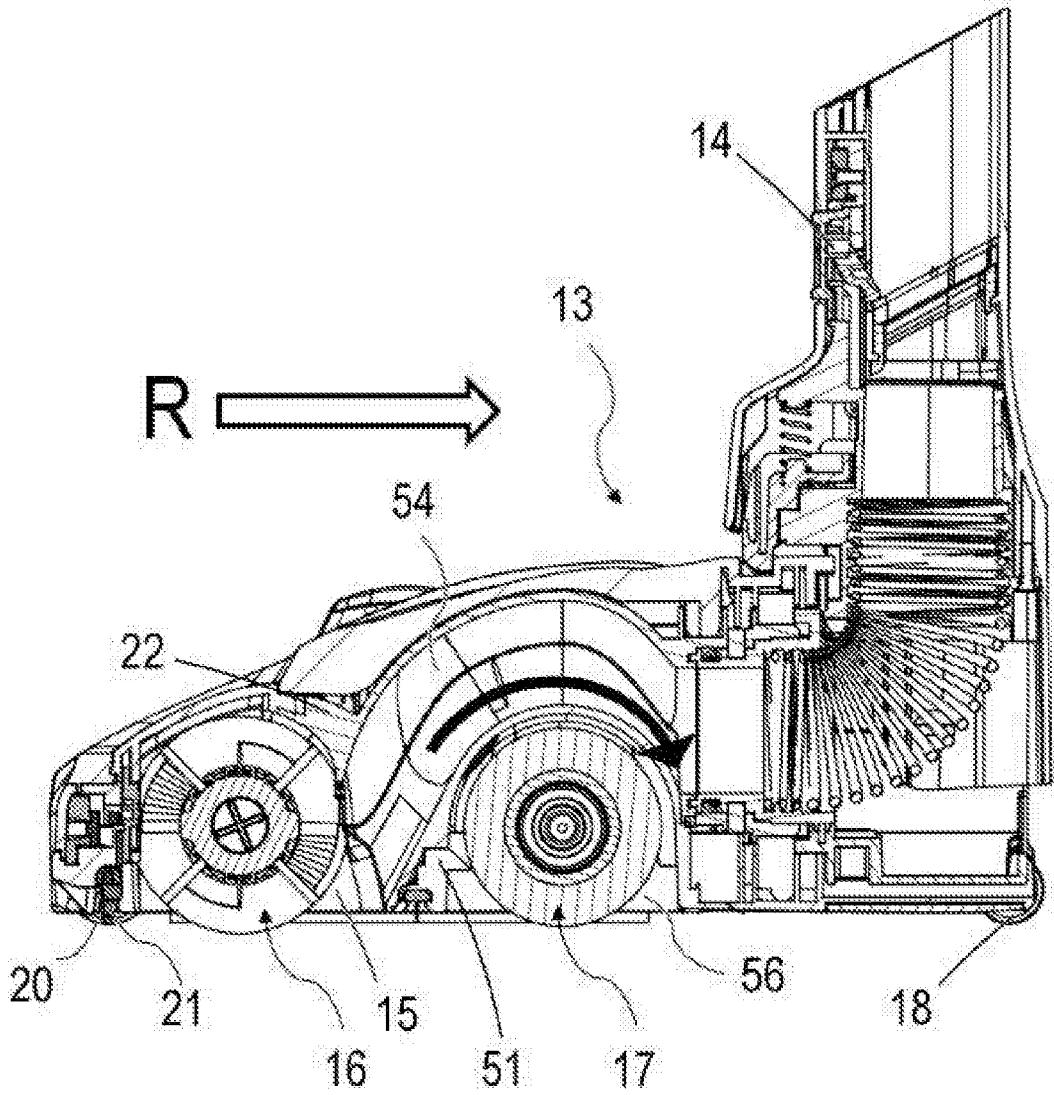

Figure 4

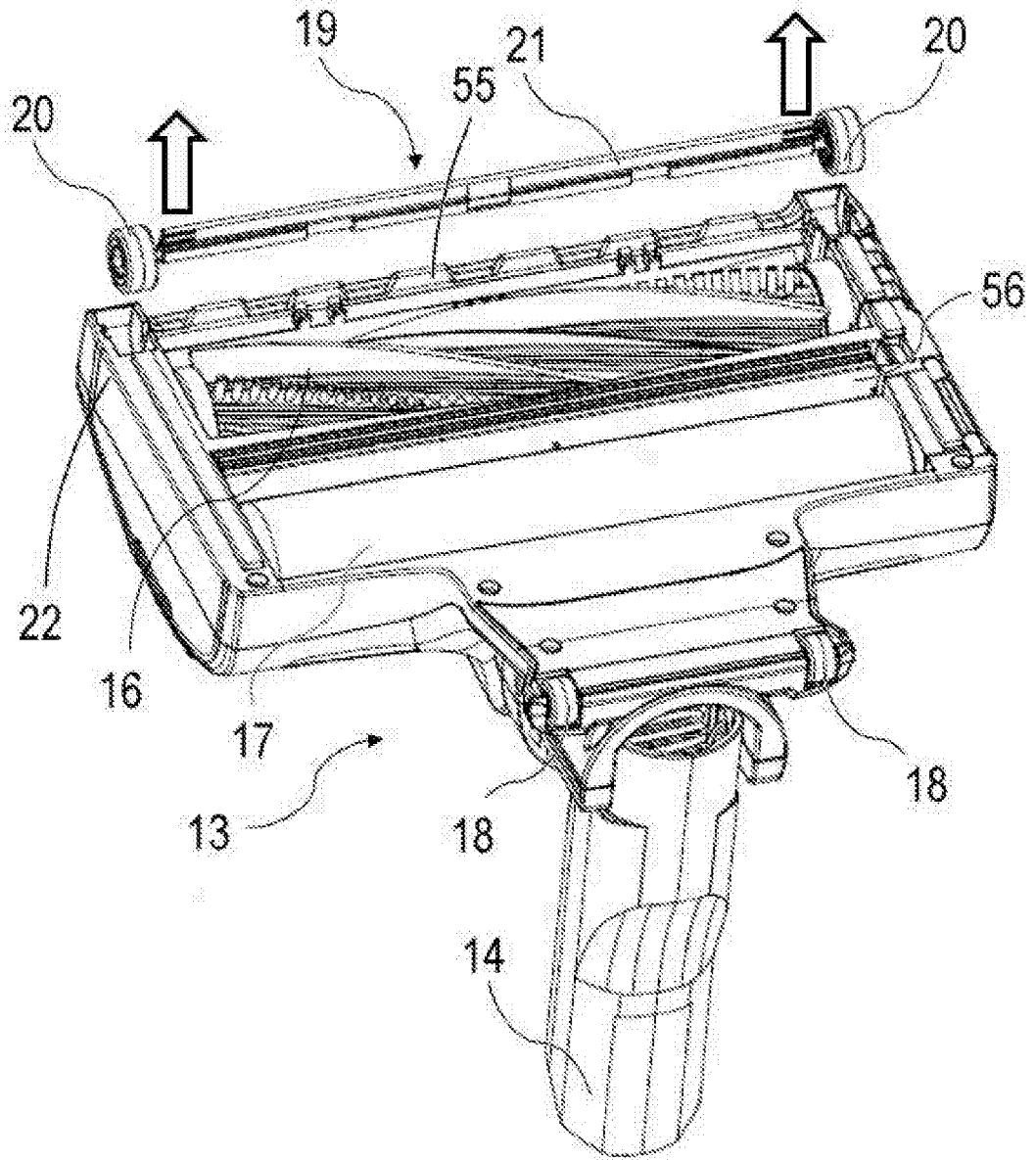

Figure 5

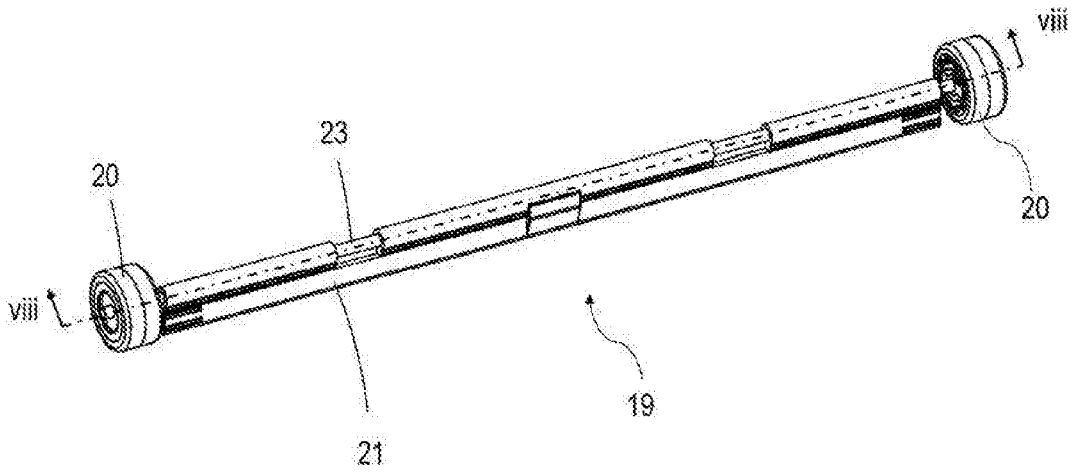

Figure 6

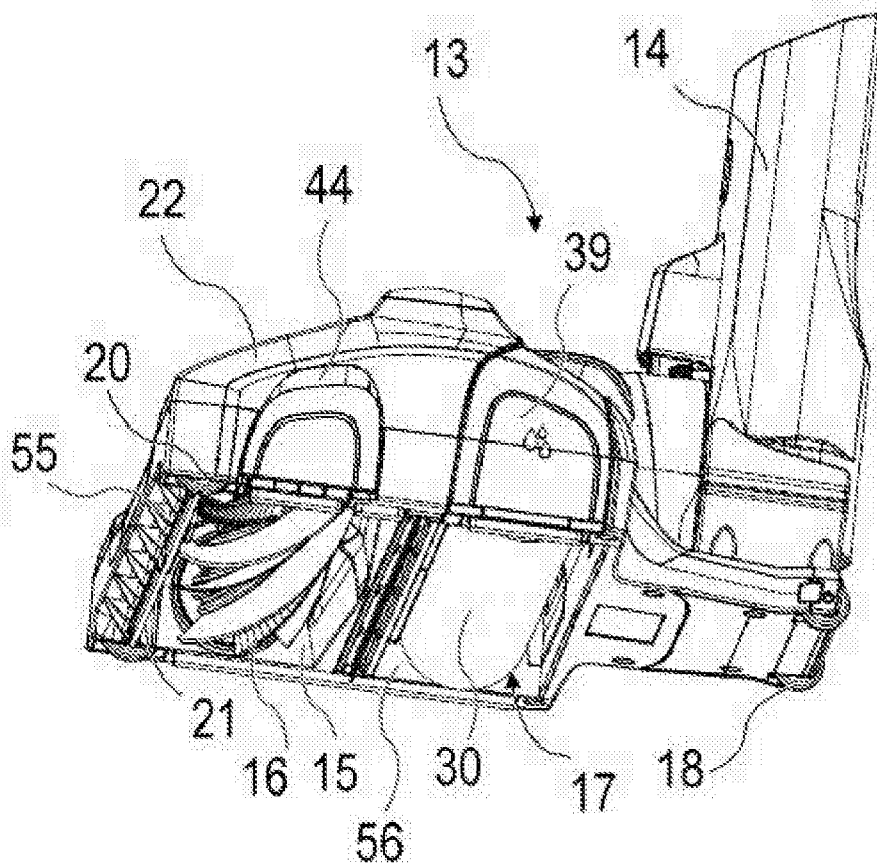

Figure 7

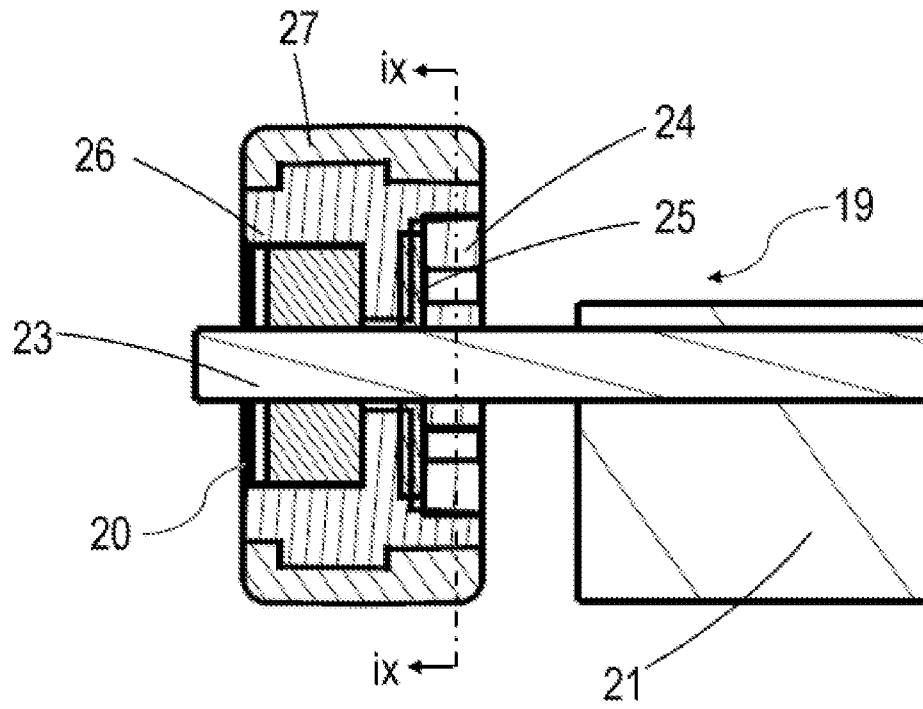

Figure 8

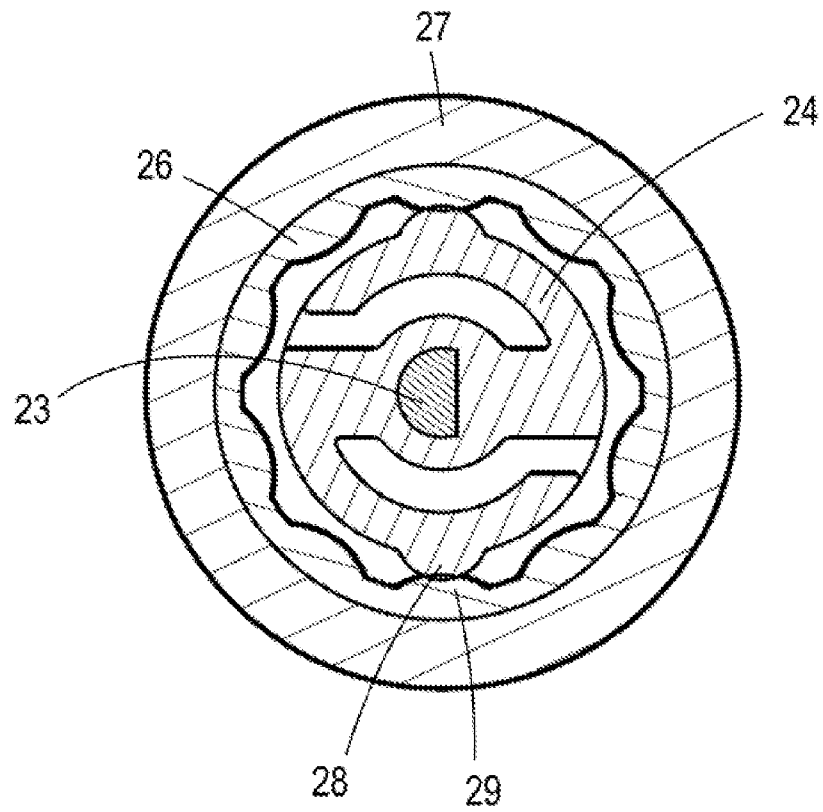

Figure 9

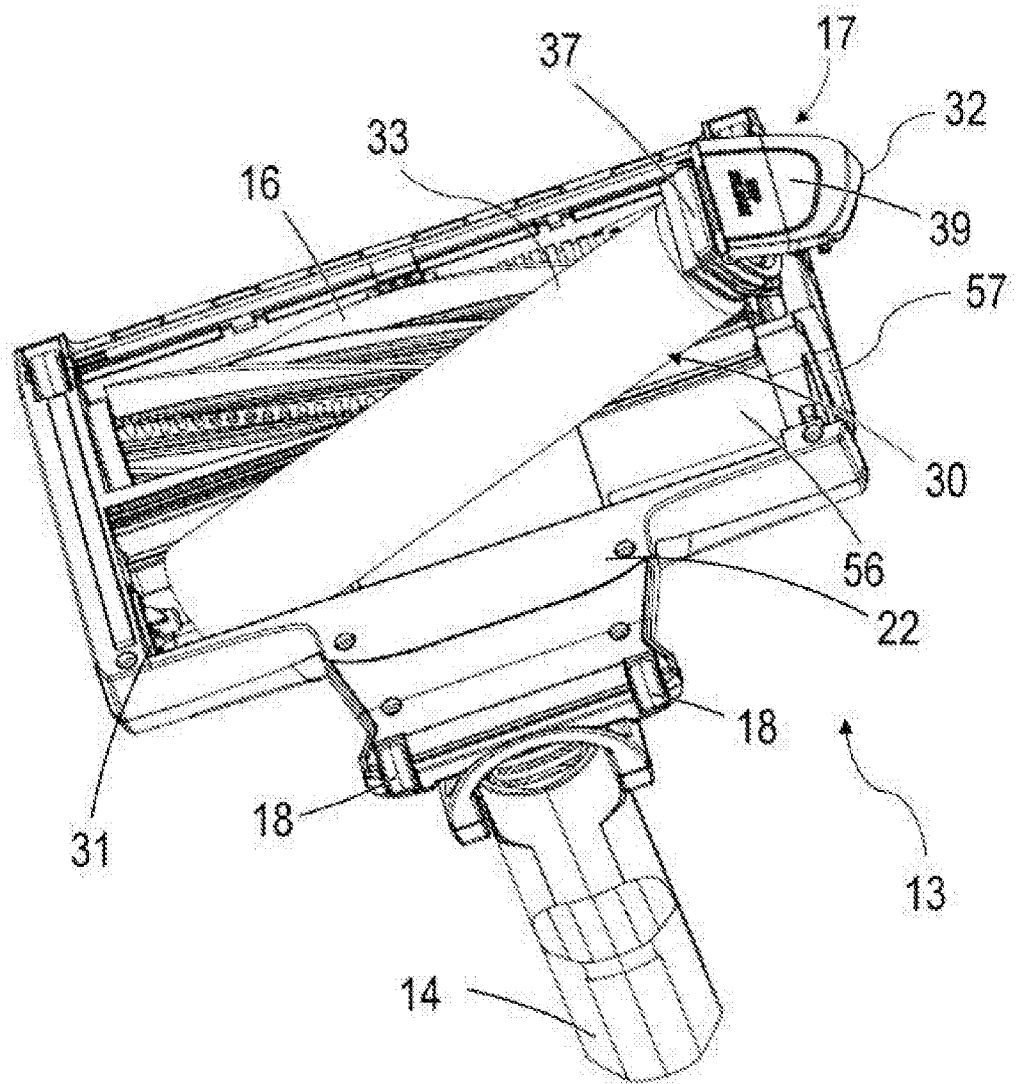

Figure 10

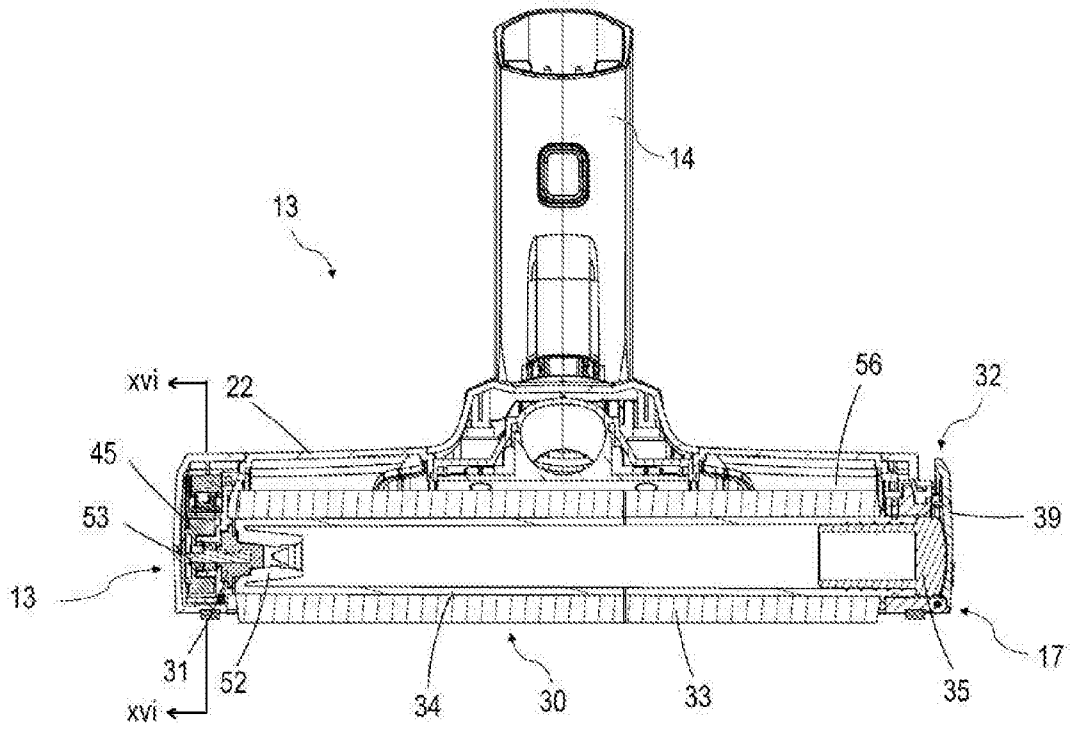

Figure 11

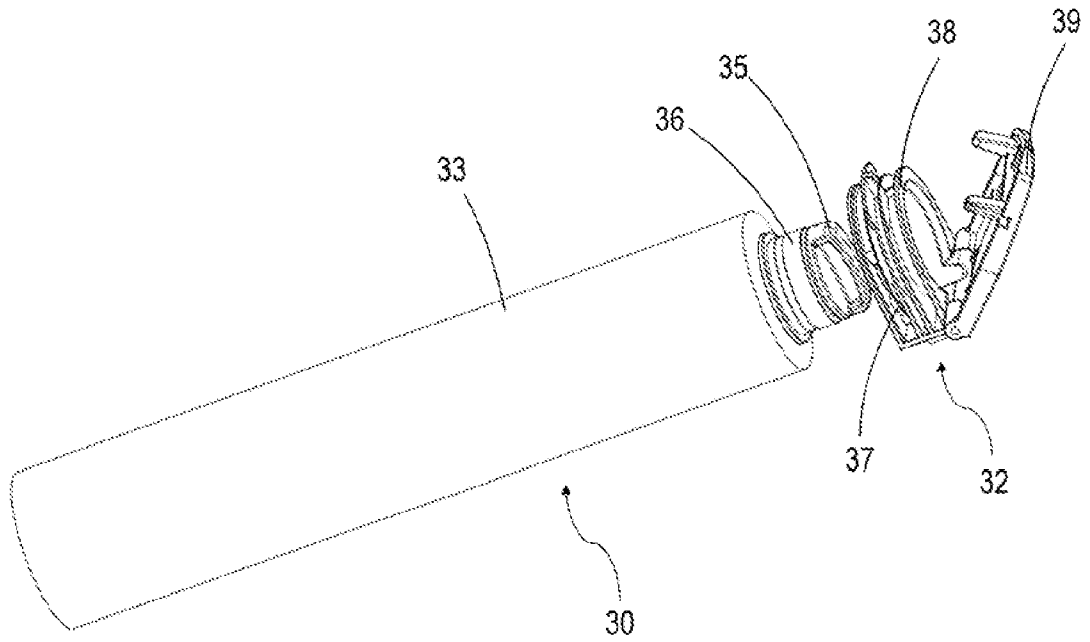

Figure 12

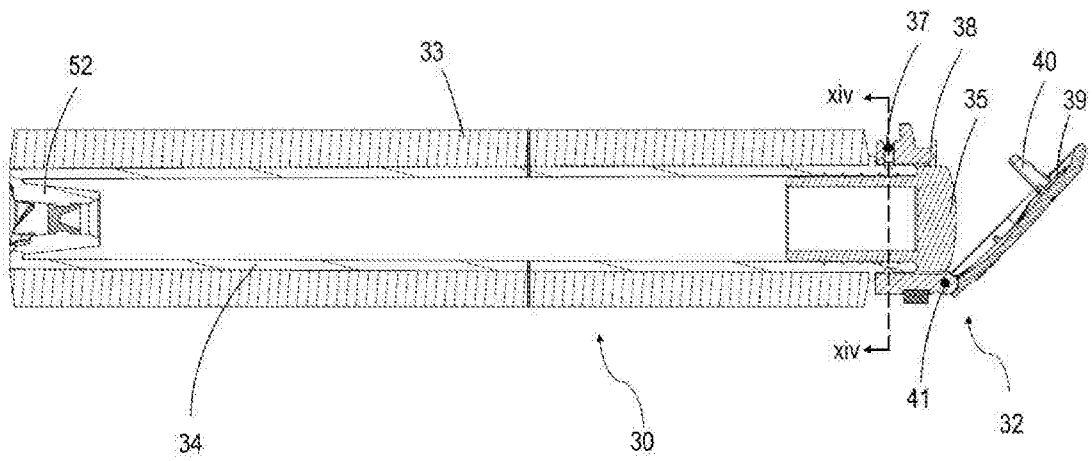

Figure 13

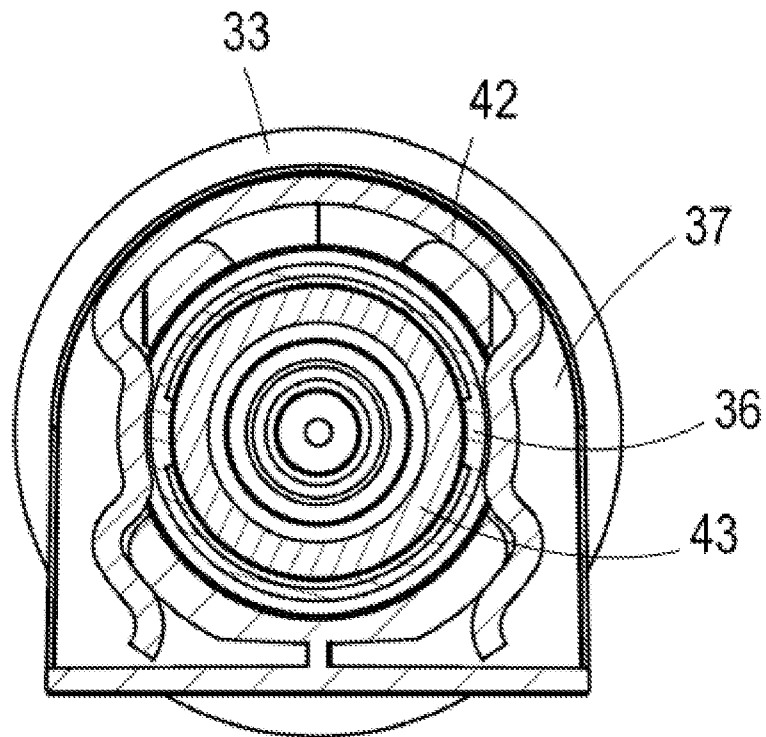

Figure 14

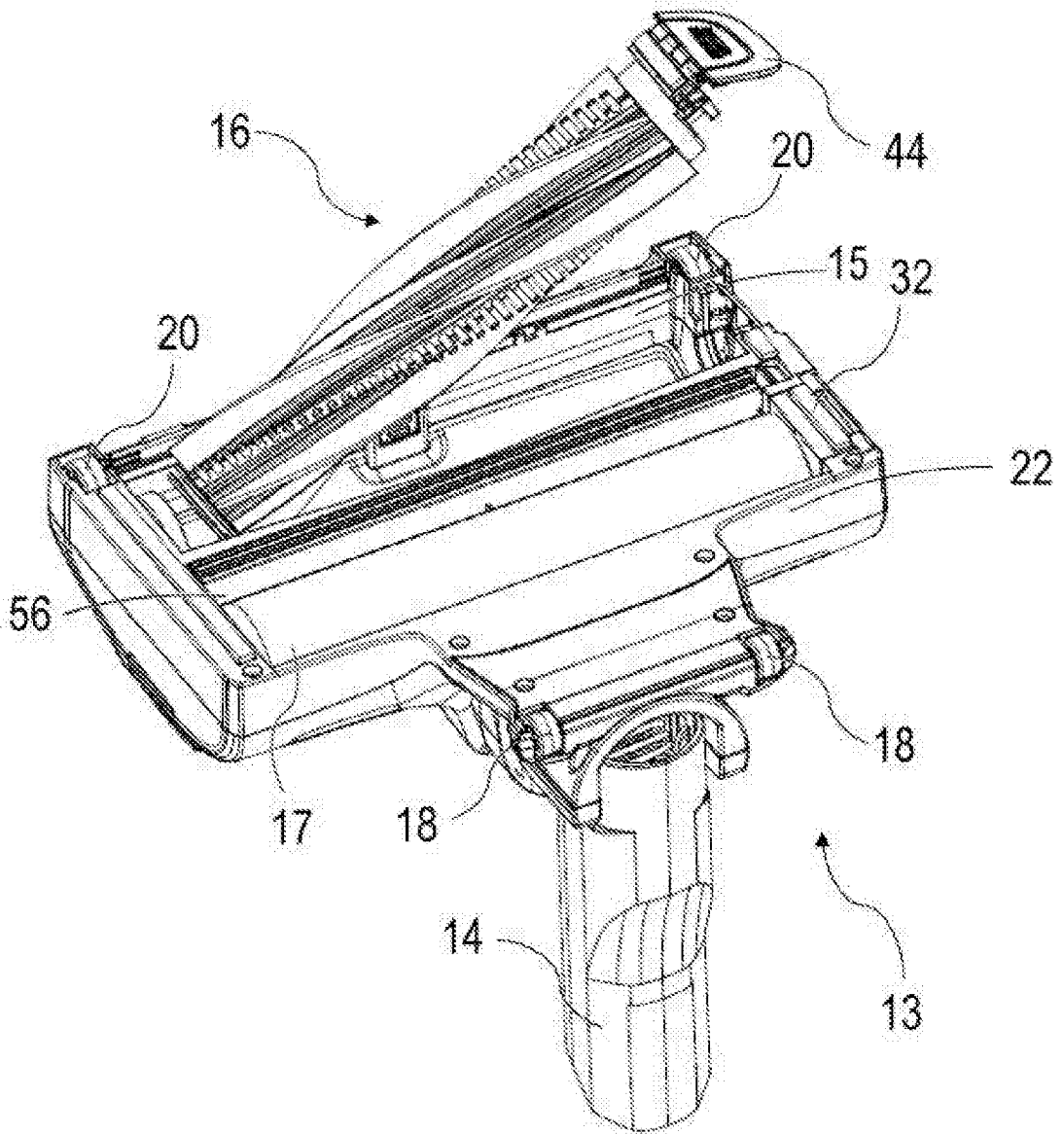

Figure 15

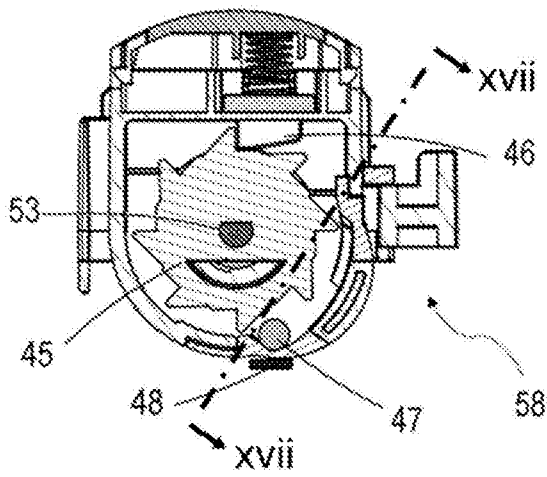

Figure 16A

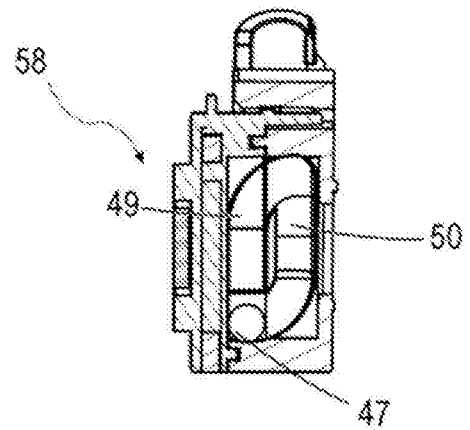

Figure 16B

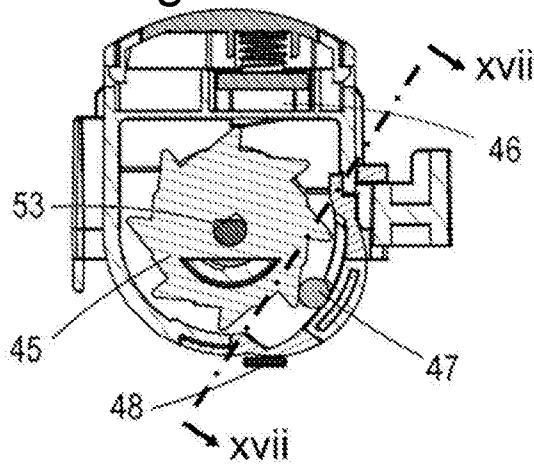

Figure 17A

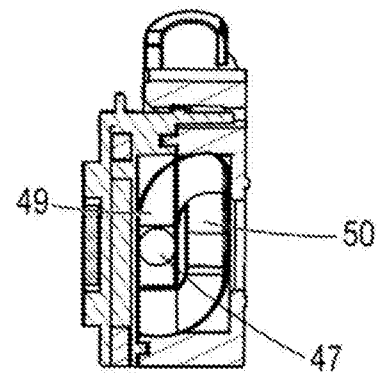

Figure 17B

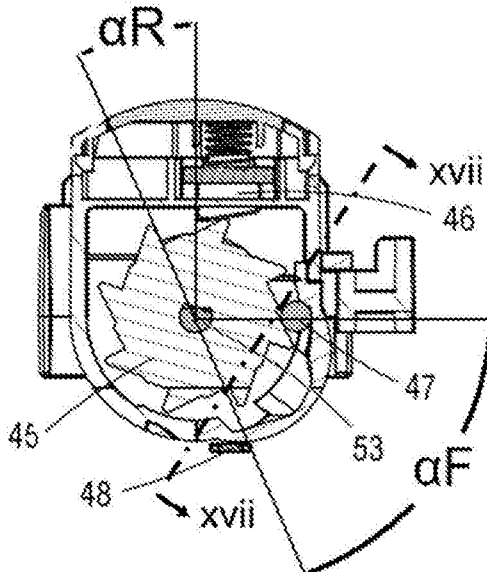

Figure 18A

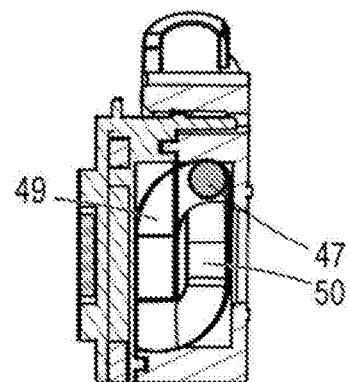

Figure 18B

Floor Cleaning Head

This invention relates to a floor cleaning head for a vacuum cleaner and to a vacuum cleaner including the same.

Hitherto, vacuum cleaners have generally been designed with cleaning carpets in mind. However, many people nowadays are favouring hard floors such as wooden floors, laminate floors and tiles over carpets. Also, the nature of hard floors is that vacuum cleaning alone is often insufficient to clean them properly and to provide a pleasing appearance. Thus, the object of the present invention is to provide a vacuum cleaner which is more adapted for cleaning hard floor surfaces than conventional vacuum cleaners, yet is not so mechanically complex that it is unaffordable for domestic users.

With the foregoing objects in mind, we have now devised an improved floor cleaning head for a vacuum cleaner.

In accordance with the present invention, there is provided a floor cleaning head for a vacuum cleaner, the head comprising:

- a housing having a front, a rear, a top, a bottom and opposite sides;

- an elongate suction mouth extending across the bottom of the housing between opposite sides thereof through which dirt and dust is drawn into the vacuum cleaner during use;

- an elongate cavity extending across the bottom of the housing between opposite sides thereof; and

- a detachable elongate floor cleaning roller mounted axially in the cavity and extending in parallel with the agitator, the floor cleaning roller comprising a tubular core forming a dispensing container and a surrounding sleeve of an absorbent material configured to wipe the floor surface during cleaning.

If desired, prior to use the detachable elongate floor cleaning roller can be detached from the floor cleaning head so that the dispensing container thereof can be filled with water or a liquid for cleaning, disinfecting, polishing or otherwise treating the floor surface.

A vacuum cleaner in accordance with the present invention is simple and inexpensive in construction yet is able to carry out substantially improved cleaning of hard floor surfaces, due to the conventional sweeping action of the agitator combined with the

washing, wiping or drying action provided by the floor cleaning roller depending on whether it is used wet or dry.

The floor cleaning roller may comprise a first end for engaging a support at a first end of the cavity and a second end defining a neck of the container, wherein a clip is rotatably mounted to the neck of the container for detachably engaging the housing of the cleaner at a second end of the cavity. The clip may be detachable from the neck of the container.

The clip may comprise an apertured body for receiving the neck of the container and a flap having a closed position in which the aperture is closed, the flap having a formation adapted to engage the housing of the cleaner when the flap is in its closed position. The body of the clip may have a peripheral channel for receiving a formation on housing.

A rotatable collar may be mounted on the neck of the container, the clip being adapted to engage the rotatable collar.

The agitator may be detachably mounted in the suction mouth, a clip being rotatably mounted to one end of the agitator for detachably engaging the housing of the cleaner and one end of the suction mouth.

The core of the floor cleaning roller comprises an apertured side wall through which any liquid contained within the container is able to wet the surrounding absorbent material.

An elongate wiper may extend axially of the cavity, the outer end of the wiper contacting the sleeve of absorbent material surrounding the roller. The wiper serves to clean the cleaning roller of any matter which it may have picked up from the floor.

The floor cleaning roller may be mounted rearwardly of the agitator on the bottom of the head. On the forward stroke the cleaning roller applies any water or other liquid contained within onto the floor surface immediately after it has been cleaned by the agitator. On the rearward stroke any stubborn dirt or other matter that has been cleaned by the action of the cleaning roller is then picked up by the agitator.

The floor cleaning roller may solely rotate by frictional contact with the floor surface during cleaning and thus the need to provide any complex motor or other drive mechanism is avoided.

Rotation of the floor cleaning roller may be intermittently inhibited during cleaning so that the roller acts to wipe or abrade the floor surface being cleaned as the cleaning head is moved across the floor by the user.

An elongate flap may be disposed adjacent the agitator on the bottom of the housing, the flap extending parallel with the agitator and being mounted for pivotal movement about its longitudinal axis between a raised position and a lowered position, wherein means are provided for raising the flap when the head is moved across the floor surface in a first direction and for lowering the flap when the head is moved across the floor surface in a second opposite direction.

In use, when the cleaning head is moved across the floor surface in the first direction the flap is raised and the cleaning head is able to pass unhindered over relatively large pieces of dirt and other detritus matter that has collected on the floor, so that the matter is picked up by the agitator and carried away in the airflow for separation and collection. When the cleaning head is moved across the floor surface in the opposite, the flap is lowered so that any matter that was not picked up whilst the head was moved in the first direction becomes trapped under the head adjacent the suction mouth where the likelihood of it being picked up is substantially increased. In this manner, the cleaning ability of the head is substantially improved.

The flap may be positioned forwardly of the agitator, said means being arranged to raise the agitator when the head is moved in a forward direction and lower the agitator when the head is moved in a rearward direction.

The flap may be positioned at a front edge of the housing.

The flap may pivoted about its longitudinal axis between the raised position and the lowered position by a wheel arranged to frictionally engage the floor surface being cleaned.

The wheel may be arranged to rotate about the axis about which the flap pivots.

The flap may comprise an axle which extends between a pair of wheels.

The flap may be connected to the wheel by a clutch arranged to slip once the wheel has pivoted the flap fully in its direction of rotation, the head of the cleaner comprising a pair of abutment surfaces for controlling the extent of rotation of the flap about its longitudinal axis between the raised and lowered positions.

A hub may be provided for rotating the flap, the hub having a hub surface lying normal to the axis of rotation of the flap, the clutch comprising a frictional pad constrained between the wheel and the hub surface. The pad may be formed of felt or another fibrous material.

The hub and the wheel may resiliently engaged with each other in order to limit the freedom of movement of the flap.

The bottom of the housing may be provided with a plurality of downwardly projecting formations disposed at intervals along the line which extends parallel with the longitudinal axis of the flap, the flap being disposed between the formations and the agitator so that the formations provide a said abutment surface for the flap in its lowered position. When the flap is in its lowered position it acts to close the space between the formations and thus restricts the amount of air that can flow under the cleaner.

Also, in accordance with the present invention, there is provided vacuum cleaner comprising a floor cleaning head as hereinbefore defined.

The floor cleaning roller may be adapted to rotate solely by frictional contact with the floor surface during movement of the head across the floor surface being cleaned, the head comprising a control mechanism for intermittently inhibiting rotation of the roller whilst the head is moved in first and second directions across the floor surface being cleaned.

In use the control mechanism inhibits rotation of the roller so that the static roller acts to frictionally wipe and abrade the floor. The rotational movement helps to stop the

same rotational part of the roller from always statically engaging the floor, thereby avoiding wear.

The control mechanism may be arranged such that rotation of the roller is inhibited over a shorter distance of movement of the head in the first direction than it is in the second direction. This arrangement further helps to avoid the likelihood of the same occasional part of the roller statically engaging the floor on successive movements of the cleaner.

The control mechanism may be arranged such that rotation of the roller is not inhibited during movement of the head in the first direction.

The control mechanism may be arranged such that rotation of the roller is inhibited after a distance of movement of the head in the first direction.

The control mechanism may be arranged such that rotation of the roller is entirely inhibited during movement of the head in the second direction.

The control mechanism may be arranged such that rotation of the roller is inhibited after a distance of movement of the head in the second direction.

The control mechanism may be arranged such that rotation of the roller is inhibited after a distance of movement of the head in the first direction.

The control mechanism may be arranged such that said distance of movement of the head in the first direction is greater than said distance of movement of the head in the second direction.

The control mechanism may be arranged such that the first direction is the forward direction and the second direction is the rearward direction.

The control mechanism may comprise a ratchet having a pawl which engages a toothed gear to partially inhibit rotation of the roller in the second direction.

The control mechanism may comprise a ball mounted in an endless orbital passageway formed in a body portion thereof, the passageway comprising a first

section which ends circumferentially of the toothed gear and a second portion disposed away from the toothed gear, the passageway portions being connected end to end, the mechanism being arranged such that the ball is urged along the first portion of the passageway by the toothed gear as the head is moved in the first direction until it abuts a formation, whereupon rotation of the toothed gear and roller is inhibited in a position where the pawl is seated on a radially outward portion of a tooth of the gear, the mechanism being arranged such that the ball is released to travel along the second portion of the passageway when the head is moved in the second direction, whereupon rotation of the toothed gear and roller is not inhibited until the pawl engages a radially inward portion of an adjacent tooth of the gear.

Also, in accordance with the present invention, there is provided a method of cleaning a floor surface using a floor cleaning head as hereinbefore defined.

An embodiment of the present invention will now be described by way of example only and with reference to the accompanying drawings, in which:

Figure 1 is a front perspective view of a vacuum cleaner having a cleaning head in accordance with the present invention;

Figure 2 is a bottom view of the cleaning head of Figure 1;

Figure 3 is a sectional view along the line iii - iii of Figure 2 when the cleaning head is being pushed forwardly in direction F for;

Figure 4 is a sectional view along the line iii - iii of Figure 2 when the cleaning head is being pushed rearwardly in direction R;

Figure 5 is a bottom view of the cleaning head of Figure 1 illustrating removal of a wiper assembly of the cleaning head;

Figure 6 is a perspective view of the wiper assembly of Figure 5;

Figure 7 is a view from the left side and below of the cleaning head of Figure 1;

Figure 8 is a part sectional view along the line viii - viii of Figure 6 of one end of the wiper assembly;

Figure 9 is a sectional view along the line ix - ix of Figure 8;

Figure 10 is a bottom view of the cleaning head of Figure 1 illustrating removal of cleaning roller assembly of the cleaning head;

Figure 11 is a sectional view along the line xi - xi of Figure 2;

Figure 12 is a perspective side view of the cleaning roller assembly of Figure 10;

Figure 13 is a longitudinal sectional view through the cleaning roller assembly of Figure 10;

Figure 14 is a sectional view along the line xiv - xiv of Figure 13;

Figure 15 is a bottom view of the cleaning head of Figure 1 illustrating removal of an agitator assembly of the cleaning head;

Figures 16a, 17a and 18a are sectional views along the line xvi - xvi of Figure 11 sequentially illustrating operation of a ratchet for controlling the cleaning roller assembly of Figure 10; and

Figures 16b, 17b and 18b are sectional views along the line xvii - xvii of Figure Figures 16a, 17a and 18a respectively.

Referring to Figure 1 of the drawings, there is shown a hand-held cordless vacuum cleaner 10 comprising an upper body portion 11 which is detachably connected via an elongate rigid tube 12 to a floor cleaning head 13 in accordance with the present invention. The body portion 11 of the vacuum cleaner 10 comprises a motor and a fan unit (not shown) which draws air into the vacuum cleaner 10 through the floor cleaning head 13. The rear of the head 13 comprises an outlet port 14 detachably coupled to the lower end of the rigid tube 12.

Referring to Figures 2 to 4 of the drawings, the cleaning head 13 comprises a generally rectangular external housing 22 having a downwardly facing suction mouth 15 extending transversely across its width on the underside thereof adjacent the front of the head 13. The suction mouth 15 at the front of the head 13 is fluidly connected to the outlet port 14 at the rear of the head 13 via a duct 54 which extends rearwardly inside the housing 22. A detachable rotary motor-driven agitator brush 16 extends across the suction mouth 15 for sweeping and beating or abrading the floor surface during cleaning.

A detachable cleaning roller assembly 17 is disposed in a downwardly facing cavity 56 that extends transversely across the width of the cleaning head 13 on the underside thereof adjacent the rear of the head 13. The cleaning head 13 is supported on the floor surface by a pair of rear wheel assemblies 18 and a pair of front wheel assemblies 20 having respective axes of rotation which extend transversely of the head 13.

Referring to Figures 5 to 9 of the drawings, the front edge of the underside of the head 13 comprises a series of castellations 55. The front wheel assemblies 20 form a part of an elongate flap assembly 19 that is detachably mounted in an elongate recess extending across the front of the cleaning head 13 on the underside thereof behind the castellations 55. The flap assembly 19 comprises an elongate flap 21 of elastomeric material which is mounted on an elongate axle 23 which extends between the wheel assemblies 20. Each end of the axle 23 is coupled to a hub 24 having a pair of circumferentially extending arms of resiliently flexible material. Each wheel assembly 20 comprises a tyre 27 mounted on a wheel 26, the hubs 24 being mounted inside the wheels 26 such that formations 28 on the arms of each hub 24 abut a ridged radially-inwardly facing surface 29 of the respective wheel 26. The axially outer face of each hub 24 bears against a frictional pad 25 mounted on the centre of the respective wheel 26.

Referring to Figures 10 to 14 of the drawings, the cleaning roller assembly 17 comprises a roller portion 30 having a tubular outer portion 33 formed of an absorbent material such as sponge or cotton. The tubular outer portion 33 of the roller 30 extends around a tubular core 34 which forms a dispensing container. The container is closed at one end and comprises a tubular neck 43 at its opposite end. A roller support spigot 31 extends axially into the roller cavity 56 from one side of the housing 22. The closed end of the tubular core 34 of the roller 30 comprises a socket 52 adapted to

receive the spigot 31. The opposite end of the roller 30 is detachably connected to the housing 22 at the opposite end of the roller cavity 56 by a mount portion 32 of the cleaning roller assembly 17.

A rotatable annual collar 36 is captively mounted around the neck 43 of the roller 30. A closure 35 in the form of a stopper is sealingly engaged with the neck 43 of the roller 30. The mount 32 of the cleaning roller assembly 17 comprises a body 37 which defines an aperture for receiving the neck 43 of the roller 30. A c-shaped clip 42 is provided on the body 37 for resiliently engaging the rotatable annual collar 36 when the neck 43 of the roller 30 is inserted into the body aperture. An outwardly facing u-shaped channel 38 extends around three sides of the body 37 of the mount 32. A flap 39 is pivotally mounted to the body 37 of the mount 32 by an axle 41 and is arranged to close the body aperture when in its closed position. A pair of fingers 40 project outwardly from the inner face of the flap 39.

The roller assembly 17 is fitted in the cavity 56 of the head 13 by inserting the end thereof having the socket 52 into the cavity 56 and then displacing the roller assembly 17 axially until the socket 52 engages the spigot 31. The end of the roller assembly 17 having the mount 32 is then pivoted towards the housing 22 so that the U-shaped channel 38 thereon engages with a complementary U-shaped recess 57 at one end of the cavity 56 in the housing 22. The cleaning roller assembly 17 is then secured in situ by closing the flap 39 so that the fingers 40 thereon engage into corresponding apertures (not shown) in the housing 22.

An elongate wiper 51 of elastomeric material is disposed in the roller cavity 56 and is positioned such that its outer end engages the surface of the roller 30.

Referring to Figure 15 of the drawings, the agitator 16 comprises a first end adapted for engaging a motorised drive spigot mounted at one end of the suction mouth 15. The other end of the agitator 16 is detachably connected to the housing 22 at the opposite end of the suction mouth 15 by a mount portion 44 which is similar in construction to the mount 32 of the cleaning roller assembly 17.

Referring to Figures 16b to 18b of the drawings, there is shown a control mechanism 58 for controlling the rotation of the roller 30 of the cleaning roller assembly 17. The mechanism 58 is mounted inside the housing 22 of the cleaning head 13 at one end

of the cavity 56. The mechanism 58 comprises an axle 53 on which the spigot 31 is mounted. The axle 53 is connected to a toothed ratchet gear 45 of the mechanism 58. A pawl 46 is spring biased against the toothed gear 45 so that the gear 45 can only freely rotate in the counter-clockwise direction as shown in the Figures.

A ball 47 is mounted in an endless orbital passageway formed in the body of the mechanism 58. The passageway comprises a first section 49 which extends upwardly from its lowermost point in a direction which extends circumferentially and radially of the gear 45 for approximately 90 degrees. The upper end of the first section 49 of the passageway is turned axially inwardly of the gear 45. A second section 50 of the passageway extends downwardly to its lower end where it turns axially outwardly of the gear 45 to connects with the lower end of the lower end of the first section 49. A magnet 48 is provided at the lower end of the first section 49 so ensure the ball 47 returns to the correct position.

The operation of the vacuum cleaner head 13 as hereinbefore described will now be explained with reference to all of the accompanying drawings. In use, the vacuum cleaner 10 is energised and the head 13 thereof is guided by the user over the floor surface to be cleaned using repeated forward and rearward strokes as illustrated by arrows F and R shown in Figures 3 and 4 respectively. Energisation of the vacuum cleaner operates the motor and a fan unit (not shown) in the body 11 of the cleaner 11 to draw air into the vacuum cleaner 10 through the inlet 15 of the floor cleaning head 13. Energisation of the vacuum cleaner also operates a motor (not shown) disposed in the cleaning head 13 which drives the agitator 16 about its rotational axis. Dirt, dust and other matter is picked up from the floor by the rotation of the agitator 16 and the induced vacuum under the head 13, whereupon it is conveyed upwardly by the airflow to the body portion 11, where it is separated by a cyclone separator or other separation device (not shown) and collected for emptying.

As shown in Figure 3 of the drawings, rotation of the front wheel assemblies 20 when the cleaning head 13 is pushed forwardly in direction F causes the wheels 26 to frictionally engage the hubs 24 by means of the frictional pads 25 disposed therebetween. This causes the axle 23 of the flap assembly 19 to rotate about its axis into a raised position where the flap 21 extends rearwardly generally parallel to the floor surface. This creates a large opening at the front of the cleaning head 13 so that

the cleaning head can freely pass over dirt, dust and other detritus to be cleaned from the floor.

As shown in Figure 4 of the drawings, rotation of the front wheel assemblies 20 when the cleaning head 13 is pulled rearwardly in direction R causes the wheels 26 to frictionally engage the hubs 24 by means of the frictional pads 25 disposed therebetween. This causes the axle 23 of the flap assembly 19 to rotate about its axis into a lowered position where the flap 21 extends downwardly towards the floor surface and into a position where it is biased against the rear face of the castellations 55 so as to close the gaps therebetween. This has the effect of substantially reducing the size of the opening at the front of the cleaning head 13, so that dirt, dust and other detritus becomes trapped under the cleaning head 13 by the flap 21 in a position directly under the suction mouth 15. In this manner, the ability of the cleaning head 13 to pick up matter from the floor is substantially improved because any matter that is not picked up during the forward stroke is trapped and picked up on the rearward stroke.

As will be explained hereinafter, the cleaning action of the cleaner 10 is greatly enhanced by the operation of the cleaning roller assembly 17 disposed behind the agitator 15 on the underside of the cleaning head 13. The roller 30 of the assembly 17 is mounted in a position such that it bears against the floor surface being cleaned. Prior to use, the cleaning roller assembly 17 can be detached from the underside of the cleaning head 13 by releasing the flap 39 to allow the container formed by the tubular roller core 34 to be filled with water or a liquid for cleaning, disinfecting, polishing or otherwise treating the floor surface. The roller core 34 is provided with apertures (not shown) which allow the liquid therein to wet the surrounding absorbent tubular outer portion 33. If desired, the roller 30 does not have to be filled with liquid and it can be used dry, for example by

In one embodiment, the ball 47 is omitted from the roller control mechanism 58. In this embodiment, the pawl 46 rides over the teeth of the ratchet gear 45 when the cleaning head is pushed forwardly in direction F and thus the roller 13 of the cleaning roller assembly 17 simply rolls across the floor on the forward stroke and applies any water or other liquid contained within onto the floor surface immediately after it has been cleaned by the agitator 16. On the rearward stroke, the pawl 46 prevents rotation of the roller 30, so that the roller 30 remains static and acts to abrade and scrub the floor.

On the forward stroke, the roller 30 is cleaned of any collected matter by the action of the wiper 51.

In a preferred embodiment, as will be explained hereinafter with particular reference to Figures 16A to 18B, the ball 47 of the mechanism 58 acts to control the rotation of the roller 30, so that the same region of the roller cannot abrade or scrub the floor on successive rearward strokes of the cleaner, thereby avoiding uneven wear of the roller 30.

In this embodiment, the pawl 46 rides over the teeth of the ratchet gear 45 when the cleaning head is pushed forwardly in direction F and thus the roller 13 of the cleaning roller assembly 17 rolls across the floor. At the start of the forward stroke, the ball 4 is held in the position shown in Figures 16A and 16B the by the magnet 48. However, as the cleaning head 13 is pushed forwardly in direction F, the ball 47 is lifted up the first section 49 of the passageway by one of the teeth of the ratchet gear 45 as shown in Figures 17A and 17B for an angle αF until it reaches the position shown in Figures 18A and 18B, whereupon the ball 47 becomes trapped at the top of the first portion 49 of the passageway and prevents further rotation of the roller 30 during the forward stroke, so that the roller 30 remains static and acts to abrade and scrub the floor. In this position, the pawl 46 is pressed inwardly by one of the teeth, so that on the rearward stroke the ratchet gear 45 is able to rotate by angle αR until the pawl 46 prevents further rotation of the roller 30, so that the roller 30 remains static and again acts to abrade and scrub the floor with a different part of the roller 30 than was used on the preceding forward stroke. In this manner, uneven wear of the roller is avoided.

The movement of the roller through angle αR at the start of the rearward stroke releases the ball 47 from its trapped position at the top of the first portion 49 of the passageway and allows it to drop down the second portion 50 of the passageway under gravity to its original position at the bottom of the first portion 49 of the passageway. The magnet 48 ensures that the ball 47 returns to the correct position. The process of the control mechanism 58 then repeats itself on successive strokes, with the roller 13 rotating forwardly by an angle αF on forward strokes and rearwardly by an angle αR on rearward strokes, where angle αF is greater than angle αR , so that net effect is that the roller rotates forwardly by an angle $\alpha F - \alpha R$ between successive forward strokes.

A vacuum cleaner having a cleaning head in accordance with the present invention is simple and inexpensive in construction yet is able to carry out substantially improved cleaning of hard floor surfaces, due to the sweeping action of the agitator 16 combined with the washing, wiping or drying action provided by the floor cleaning roller 30.

CLAIMS

1. A floor cleaning head for a vacuum cleaner, the head comprising:
 - a housing having a front, a rear, a top, a bottom and opposite sides;
 - an elongate suction mouth extending across the bottom of the housing between opposite sides thereof through which dirt and dust is drawn into the vacuum cleaner during use;
 - an elongate agitator roller mounted axially in the suction mouth;
 - means for rotating the agitator roller about its longitudinal axis to sweep and beat or abrade a floor surface during cleaning;
 - an elongate cavity extending across the bottom of the housing between opposite sides thereof; and
 - a detachable elongate floor cleaning roller mounted axially in the cavity and extending in parallel with the agitator, the floor cleaning roller comprising a tubular core forming a dispensing container and a surrounding sleeve of an absorbent material configured to wipe the floor surface during cleaning.
2. A floor cleaning head as claimed in claim 1, in which the floor cleaning roller comprises a first end for engaging a support at a first end of the cavity and a second end defining a neck of the container, wherein a clip is rotatably mounted to the neck of the container for detachably engaging the housing of the cleaner at a second end of the cavity.
3. A floor cleaning head as claimed in claim 2, in which the clip comprises an apertured body for receiving the neck of the container and a flap having a closed position in which the aperture is closed, the flap having a formation adapted to engage the housing of the cleaner when the flap is in its closed position.
4. A floor cleaning head as claimed in claim 2, in which a rotatable collar is mounted on the neck of the container, the clip being adapted to engage the collar.
5. A floor cleaning head as claimed in claim 1, in which the core of the floor cleaning roller comprises an apertured side wall.

6. A floor cleaning head as claimed in claim 1, in which an elongate wiper extends axially of the cavity, the outer end of the wiper contacting the sleeve of absorbent material surrounding the roller.
7. A floor cleaning head as claimed in claim 1, in which the floor cleaning roller is mounted rearwardly of the agitator on the bottom of the head.
8. A floor cleaning head as claimed in claim 1, in which the floor cleaning roller solely rotates by frictional contact with the floor surface during cleaning.
9. A floor cleaning head as claimed in claim 8, comprising means for intermittently inhibiting rotation of the floor cleaning roller during cleaning.
10. A vacuum cleaner comprising the floor cleaning head of claim 1.



Application No: GB2116887.7

Examiner: Evie Walton

Claims searched: 1-10

Date of search: 11 April 2022

Patents Act 1977: Search Report under Section 17

Documents considered to be relevant:

Category	Relevant to claims	Identity of document and passage or figure of particular relevance
X	1, 2, 4-10	CN 113229742 A (SUZHOU ZHANQIAO ELECTRIC APPLIANCES CO LTD) Figures 1 and 3
X	1, 5-10	US 2021/0204684 A1 (HEMAN-ACKAH et al.) Paragraph [0042] and figure 2C
X	1, 5-10	GB 2163640 A (HIGH SPEED COMBING LTD) Page 2, lines 3-23, and figure 2

Categories:

X	Document indicating lack of novelty or inventive step	A	Document indicating technological background and/or state of the art.
Y	Document indicating lack of inventive step if combined with one or more other documents of same category.	P	Document published on or after the declared priority date but before the filing date of this invention.
&	Member of the same patent family	E	Patent document published on or after, but with priority date earlier than, the filing date of this application.

Field of Search:

Search of GB, EP, WO & US patent documents classified in the following areas of the UKC^X :

Worldwide search of patent documents classified in the following areas of the IPC

A47L

The following online and other databases have been used in the preparation of this search report

WPI, EPODOC

International Classification:

Subclass	Subgroup	Valid From
A47L	0009/04	01/01/2006
A47L	0011/40	01/01/2006