

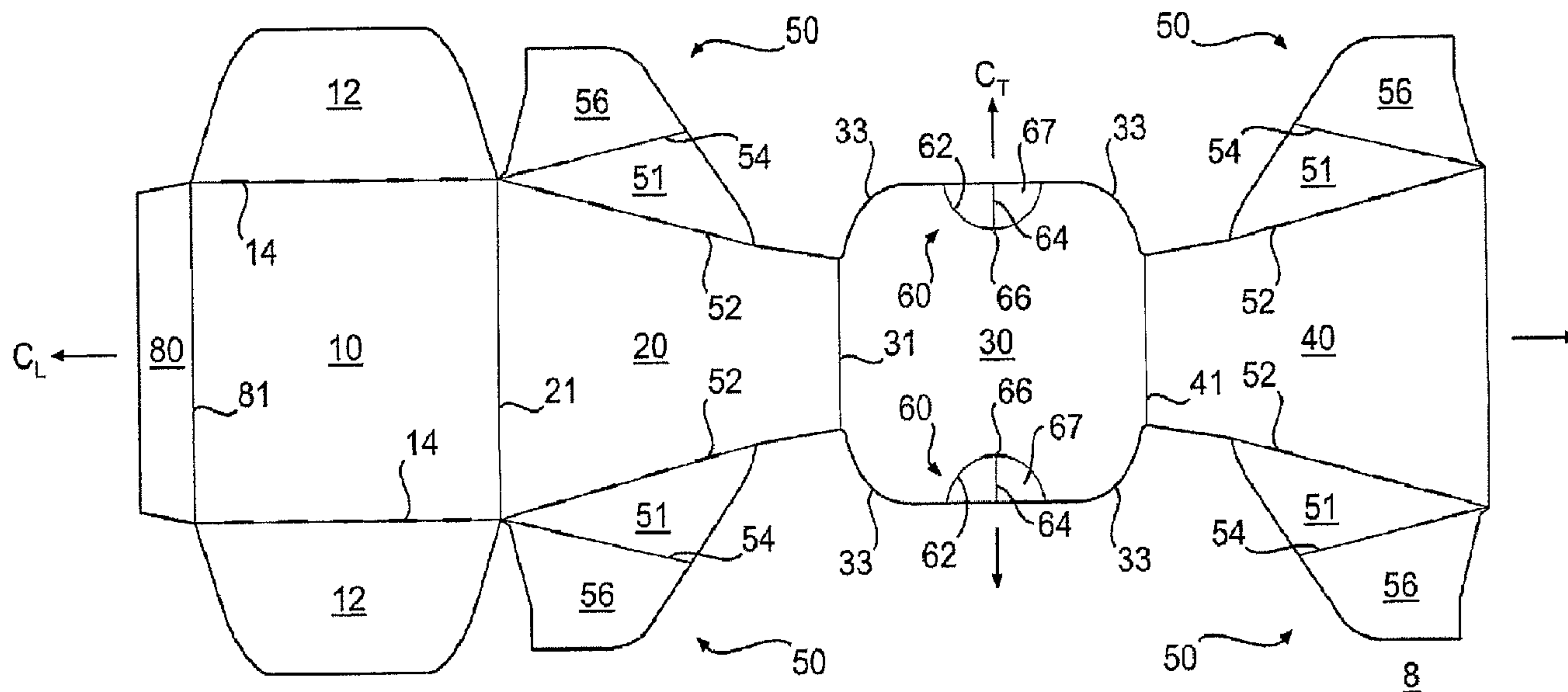

(86) Date de dépôt PCT/PCT Filing Date: 2007/01/11
 (87) Date publication PCT/PCT Publication Date: 2007/07/26
 (45) Date de délivrance/Issue Date: 2011/05/17
 (85) Entrée phase nationale/National Entry: 2008/07/11
 (86) N° demande PCT/PCT Application No.: US 2007/000737
 (87) N° publication PCT/PCT Publication No.: 2007/084333
 (30) Priorité/Priority: 2006/01/12 (US60/758,339)

(51) Cl.Int./Int.Cl. *B65D 71/00* (2006.01)
 (72) Inventeurs/Inventors:
 COLTRI-JOHNSON, ANDREA, US;
 GOMES, JEAN-MANUEL, US
 (73) Propriétaire/Owner:
 GRAPHIC PACKAGING INTERNATIONAL, INC., US
 (74) Agent: MACRAE & CO.

(54) Titre : EMBALLAGE DE TRANSPORT
 (54) Title: CARRIER PACKAGE



(57) **Abrégé/Abstract:**

A wrap-around carrier package (150) has handle features (60) formed in a top panel (30) of the package. The handle features allow a user to deform and grasp the top panel.

(12) INTERNATIONAL APPLICATION PUBLISHED UNDER THE PATENT COOPERATION TREATY (PCT)

(19) World Intellectual Property Organization
International Bureau



(43) International Publication Date
26 July 2007 (26.07.2007)

PCT

(10) International Publication Number
WO 2007/084333 A1

(51) International Patent Classification:
B65D 71/00 (2006.01)

(21) International Application Number:

PCT/US2007/000737

(22) International Filing Date: 11 January 2007 (11.01.2007)

(25) Filing Language:

English

(26) Publication Language:

English

(30) Priority Data:

60/758,339 12 January 2006 (12.01.2006) US

(71) Applicant: **GRAPHIC PACKAGING INTERNATIONAL, INC.** [US/US]; 814 Livingston Court, Marietta, GA 30067 (US).

(72) Inventors: **COLTRI-JOHNSON, Andrea**; 3138 Delacorte Drive, Acworth, GA 30101 (US). **GOMES, Jean-Manuel**; 2699 Shadow Bluff Drive, Marietta, GA 30062 (US).

(74) Agents: **ISAF, Louis, T.** et al.; Womble Carlyle Sandridge & Rice, PLLC, P.O. Box 7037, Atlanta, GA 30357-0037 (US).

(81) Designated States (unless otherwise indicated, for every kind of national protection available): AE, AG, AL, AM, AT, AU, AZ, BA, BB, BG, BR, BW, BY, BZ, CA, CH, CN, CO, CR, CU, CZ, DE, DK, DM, DZ, EC, EE, EG, ES, FI, GB, GD, GE, GH, GM, GT, HN, HR, HU, ID, IL, IN, IS, JP, KE, KG, KM, KN, KP, KR, KZ, LA, LC, LK, LR, LS, LT, LU, LV, LY, MA, MD, MG, MK, MN, MW, MX, MY, MZ, NA, NG, NI, NO, NZ, OM, PG, PH, PL, PT, RO, RS, RU, SC, SD, SE, SG, SK, SL, SM, SV, SY, TJ, TM, TN, TR, TT, TZ, UA, UG, US, UZ, VC, VN, ZA, ZM, ZW.

(84) Designated States (unless otherwise indicated, for every kind of regional protection available): ARIPO (BW, GH, GM, KE, LS, MW, MZ, NA, SD, SL, SZ, TZ, UG, ZM, ZW), Eurasian (AM, AZ, BY, KG, KZ, MD, RU, TJ, TM), European (AT, BE, BG, CH, CY, CZ, DE, DK, EE, ES, FI, FR, GB, GR, HU, IE, IS, IT, LT, LU, LV, MC, NL, PL, PT, RO, SE, SI, SK, TR), OAPI (BF, BJ, CF, CG, CI, CM, GA, GN, GQ, GW, ML, MR, NE, SN, TD, TG).

Published:

- with international search report
- before the expiration of the time limit for amending the claims and to be republished in the event of receipt of amendments

For two-letter codes and other abbreviations, refer to the "Guidance Notes on Codes and Abbreviations" appearing at the beginning of each regular issue of the PCT Gazette.

(54) Title: CARRIER PACKAGE

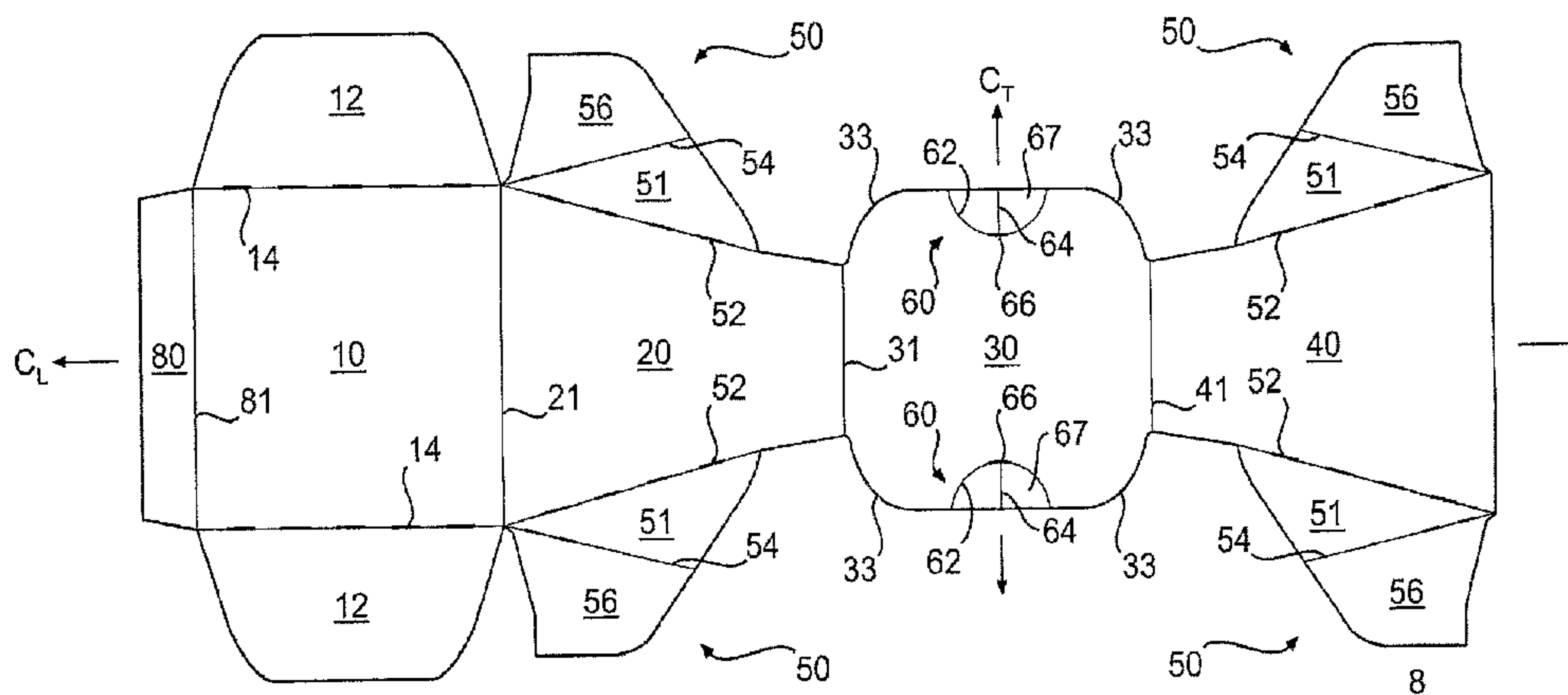

(57) Abstract: A wrap-around carrier package (150) has handle features (60) formed in a top panel (30) of the package. The handle features allow a user to deform and grasp the top panel.

WO 2007/084333 A1

CARRIER PACKAGE

[0001]

BACKGROUND

[0002] Wrap-around carrier packages are typically formed by wrapping a carrier blank around a group of containers and securing the ends of the blank together. The containers are held in place by the tightly wrapped carrier and also, typically, by heel cutouts through which the bottom portions of the containers extend. In conventional wrap-around carrier packages, however, handles are not provided, or when handles are provided, they typically reduce the integrity of the package.

SUMMARY

[0003] According to a first embodiment of the invention, a carrier package comprises a carrier having a top panel, a first side panel connected to the top panel, a second side panel connected to the top panel and disposed on a side of the carrier package opposite to the first side panel, a bottom panel, and at least partially open first and second ends. A plurality of containers are accommodated in the carrier package. One or more handles features are formed in the top panel. The handle features allow deformation of the edges of the top panel, which allows a user to easily lift and carry the carrier package. The handle features may be designed to allow deformation of the top panel without tearing, so that the integrity of the carrier package is not overly compromised.

[0004] Those skilled in the art will appreciate the above stated advantages and other advantages and benefits of various additional embodiments reading the following detailed description of the embodiments with reference to the below-listed drawing figures.

[0004.1] According to one aspect of the present invention there is provided a carrier package, comprising a bottom panel; a top panel; a first side panel; a second side panel; an at least partially open first end; an at least partially open second end; and at least one handle feature formed along an end edge of the top panel, the end edge comprising a free end edge of the top panel, the handle feature allowing deformation of the top panel without tearing so that the integrity of the carrier package is maintained.

[0004.2] According to a further aspect of the present invention there is provided a blank, comprising a bottom panel; a first bottom end flap foldably connected to a first end of the bottom panel; a second bottom end flap foldably connected to a second end of the bottom panel; a top panel; a first side panel; a second side panel; a first web portion foldably connected to a first end of the first side panel; a second web portion foldably connected to a second end of the first side panel; and a deformable first handle feature positioned along a first free end edge of the top panel, the first handle feature being adapted to allow deformation of the top panel without tearing so that the integrity of the carrier package is maintained.

BRIEF DESCRIPTION OF THE DRAWING FIGURES

- [0005] According to common practice, the various features of the drawings discussed below are not necessarily drawn to scale. Dimensions of various features and elements in the drawings may be expanded or reduced to more clearly illustrate the embodiments of the invention.
- [0006] **FIG. 1** is a plan view of a blank used to form a carrier package having handle features according to a first embodiment of the invention.
- [0007] **FIGS. 2 and 3** illustrate the carrier package loaded with containers.
- [0008] **FIG. 4** is a partial view of the carrier package illustrating the top panel of the carrier package.
- [0009] **FIG. 5** illustrates the carrier package being grasped at the handle features and lifted.

DETAILED DESCRIPTION

- [0010] **FIG. 1** is a plan view of a first side of a blank **8** used to form a carrier package **150** (illustrated in **FIGS. 3-6**) according to a first embodiment of the invention. As shown in **FIG. 1**, the carrier blank **8** may be wholly or partially symmetric about a longitudinal centerline C_L , and partially symmetric about a transverse centerline C_T . Therefore, certain elements in the drawing figures share common reference numerals in order to reflect the whole or partial longitudinal and/or transverse symmetries. The term “carrier package” generally refers to the erected carrier blank **8** and the containers **C** accommodated within the erected blank.
- [0011] The blank **8** comprises a bottom panel **10** foldably connected to a first side panel **20** at a first transverse fold line **21**, a top panel **30** foldably connected to the first side panel **20** at a second transverse fold line **31**, and a second side panel **40** foldably connected to the top panel **30** at a third transverse fold line **41**. An adhesive flap **80** may be foldably connected to the bottom panel **10** at a fourth transverse fold line **81**. Alternatively, an adhesive flap may be connected to the second side panel **40** at the opposite end of the blank **8**. The top panel **30** may have, for example, a generally square or rectangular shape with one or more

rounded, beveled or truncated corners 33. The bottom panel 10 may be, for example, generally square or rectangular.

[0012] A bottom end flap 12 may be foldably connected to each end of the bottom panel 10 at longitudinal fold lines 14. The bottom end flaps 12 serve to partially close the ends of the carrier package 150 (illustrated in FIGS. 3-6). A web portion 50 may be foldably connected to each end of the first side panel 20 at an oblique fold line 52. A web portion 50 may also be foldably connected to each end of the second side panel 40 at an oblique fold line 52. Each web portion 50 comprises a first web panel 51 and a second web panel 56 foldably connected to the first web panel 51 at an oblique fold line 54. The web portions 50, along with the bottom end flaps 12, serve to partially close the ends of the carrier package 150. The orientation of the oblique fold lines 52 causes the side panels 20, 40 to taper inwardly toward the top panel 30.

[0013] According to one aspect of the present invention, one or more handle features 60 may be formed in the top panel 30 for lifting, grasping and/or carrying of the carrier package 150. In the illustrated embodiment, two handle features 60 are formed in the top panel 30, one handle feature 60 being formed at each end edge of the top panel 30. In the exemplary embodiment, each handle feature 60 comprises a perimeter line of disruption in the form of a curved or arcuate line 62, with the perimeter line 62 delimiting a handle section 67. In FIG. 1, the perimeter lines 62 are generally semicircular, although other shapes, including discontinuous perimeter lines having linear sections, are within the scope of the present invention. A transverse, intermediate line of disruption 64 may extend from an edge of the top panel 30 to a location at or adjacent to the perimeter line 62. Longitudinal cuts or score lines 66 may be formed along or adjacent to the perimeter lines of disruption 62, such as at the intersections of the intermediate lines 64 with the perimeter lines 62.

[0014] The perimeter lines 62 and the intermediate lines 64 may be designed to allow deformation of the top panel 30 at the lines of disruption 62, 64, while not actually promoting tearing of the top panel 30 at the lines 62, 64. The lines 62, 64 may be, for example, fold lines, score lines, crease lines, cut-space lines,

combinations thereof, or other lines of disruption in the blank **8** allowing the top panel **30** to be deformed at the handle features **60**. The perimeter lines **62** may be, for example, continuous, substantially continuous or discontinuous in the blank **8**. The lines **66** can be cuts (e.g. slits) or scores at the apex of the perimeter lines **62** that facilitate pivoting of the handle section **67** when the top panel **30** is grasped at the handle features **60**.

[0015] According to one exemplary method, the carrier package **150** can be erected from the blank **8** by lying the blank flat, and placing a plurality of containers **C** (shown in **FIG. 2**) top side down on the interior surface of the top panel **30**. Glue or other adhesive may be applied to the exterior side of the adhesive flap **80** and/or to the interior side of the second side panel **40**. Glue or other adhesive is also applied to the exterior sides of each of the second web panels **56** and/or to the interior sides of the bottom end flaps **12**. The first and second side panels **20**, **40** are folded upwardly about the transverse fold lines **31**, **41**, respectively, toward the sides of the inverted containers **C**. The adhesive flap **80** is folded about the transverse fold line **81** so that it is adjacent to the container bottoms. The bottom panel **10** is then folded about the transverse fold line **21** so that it is adjacent to the container bottoms and so that its interior side contacts the exterior side of the adhesive panel **80** and is adhered thereto by the adhesive. The blank **8** is now wrapped around the containers **C** and has a generally tubular form, with open ends. Each of the web portions **50** is folded inwardly about the fold lines **52** so that they extend across the open ends of the tubular form and so that they abut the sides of adjacent containers **C**. The bottom end flaps **12** are folded upwardly about the fold lines **14** so that they adhere to the exteriors of the second web panels **56** at each end of the carrier, as shown in **FIGS. 2** and **3**.

[0016] According to an alternative method of erection, the adhesive flap **80** may be pre-glued to the second side panel **40** by folding at the transverse fold lines **21**, **41** so that the exterior side of the adhesive flap **80** contacts the interior side of the second side panel **40** and is adhered thereto. The pre-glued blank **8** may then be opened up into a generally tubular form, and the containers **C** transversely loaded into the tubular form through an open end of the blank. The open ends of the

tubular form may then be closed by the web panels **51, 56** and the bottom end flaps **12**.

[0017] Referring to **FIGS. 2 and 3**, the erected carrier package **150** includes the containers **C** securely retained therein, with the longitudinal axes of the generally cylindrical containers being perpendicular to the top and bottom panels **10, 30**. The exemplary carrier package **150** includes four beverage containers **C** arranged in a 2 x 2 arrangement, although other container arrangements are within the scope of the invention.

[0018] As shown in **FIGS. 2 and 3**, the ends of the carrier package **150** may be partially open, exposing upper portions of the sides of the containers **C** to view. The sides of the carrier package **150** are substantially closed by the tapered first and second side panels **20, 40**. During erection, the carrier package **150** can be wrapped relatively tightly around the containers **C** so that the web portions **50** slightly bend or otherwise deform at the lines of disruption **54**, which in turn causes the panels **51, 56** to partially conform to the exterior surfaces of adjacent containers **C**. In the illustrated embodiment, the web portions **50** and the bottom end flaps **12** close a substantial portion of the lower ends of the carrier package **150**. The degree to which the ends of the carrier package **150** are closed may be varied, for example, so that varying degrees of the containers **C** are visible.

[0019] **FIG. 4** is a partial view of the carrier package **150** illustrating the top panel **30**. The handle features **60** are arranged in the top panel **30** for lifting, grasping and/or carrying of the carrier package **150**. Each handle feature **60** provides a location at which the top panel **30** can be deformed according to a predetermined pattern in order to facilitate grasping of the carrier package **150**. Each handle feature **60** is located at an edge of the top panel **30**, adjacent to a partially open end of the carrier package **150**. Additional handle features may be, for example, located at other parts of the top panel **30**, such as at or adjacent to the fold lines **31, 41**.

[0020] **FIG. 5** illustrates a user accessing the handle features **60** in the top panel **30**. The carrier package **150** may be grasped by placing opposed fingers on the end edges of the top panel **30** at the handle sections **67**, and squeezing the top

panel **30** inwardly. Squeezing the top panel **30** at the handle features **60** causes the top panel **30** to deform inwardly at the opposed end edges of the top panel **30**. Referring also to **FIG. 4**, the handle sections **67** may deform such that they pivot about the lines **62**, **66**, and bend inwardly at the lines **64**. The handle features **60** may be located in the top panel **30** between adjacent containers **C** so that the handle sections **67** deform inwardly without interference from the containers **C**. Deformation of the top panel **30** provides a secure grip for lifting of the carrier package **150**.

[0021] The exemplary carrier package **150** is illustrated as accommodating generally cylindrical 8.3 fluid ounce beverage cans. Other types of containers, however, can be accommodated within carrier packages according to the present invention. Generally cylindrical 12 ounce beverage cans, for example, could be used. The dimensions of the blank **8** may generally be altered to accommodate various container forms.

[0022] Additional containers **C** can be accommodated in a carrier package according to principles of the present invention, for example, by adjusting the length of the blank **8**. For example, the top panel **30**, the bottom panel **10** and the bottom end flaps **12** can be lengthened along the longitudinal direction of the blank **8** (measured from left to right in **FIG. 1**) in order to accommodate additional containers **C**. In one such alternative embodiment, a carrier package may be constructed that accommodates six containers arranged in three rows and two columns (3 x 2).

[0023] The blank according to the present invention can be, for example, formed from coated paperboard and similar materials. For example, the interior and/or exterior sides of the blank can be coated with a clay coating. The clay coating may then be printed over with product, advertising, price coding, and other information or images. The blank may then be coated with a varnish to protect information printed on the blank. The blank may also be coated with, for example, a moisture barrier layer, on either or both sides of the blank.

[0024] In accordance with the exemplary embodiments, the blank may be constructed of paperboard of a caliper such that it is heavier and more rigid than ordinary paper. The blank can also be constructed of other materials, such as cardboard, hard paper, or any other material having properties suitable for enabling the carrier package to function at least generally as described above. The blank can also be laminated to or coated with one or more sheet-like materials at selected panels or panel sections.

[0025] For purposes of the description presented herein, the term “line of disruption” can be used to generally refer to, for example, cut lines, score lines, crease lines, tear lines, fold lines, and combinations thereof, formed in a blank.

[0026] A fold line can be any substantially linear, although not necessarily straight, form of disruption or weakening in the blank that facilitates folding therealong. More specifically, but not for the purpose of narrowing the scope of the present invention, examples of fold lines include: score lines; crease lines; a cut or a series of cuts that extend partially into and/or completely through the material along a desired line of weakness; and various combinations of these features.

[0027] The above embodiment may be described as having one or panels adhered together by glue. The term “glue” is intended to encompass all manner of adhesives commonly used to secure various portions of the blank.

[0028] The description is not intended to limit the invention to the form disclosed herein. Also, it is intended that the appended claims be construed to include alternative embodiments, not explicitly defined in the detailed description.

WHAT IS CLAIMED IS:

1. A carrier package, comprising:
 - a bottom panel;
 - a top panel;
 - a first side panel;
 - a second side panel;
 - an at least partially open first end;
 - an at least partially open second end; and
 - at least one handle feature formed along an end edge of the top panel, the end edge comprising a free end edge of the top panel, the handle feature allowing deformation of the top panel without tearing so that the integrity of the carrier package is maintained.
2. The carrier package of claim 1, wherein the first end of the carrier package is at least partially closed by a first bottom end flap.
3. The carrier package of claim 1 or 2, wherein the first end of the carrier package is at least partially closed by a first web portion foldably connected to the first side panel and a second web portion foldably connected to the second side.
4. The carrier package of claim 3, wherein the first web portion comprises:
 - a first web panel foldably connected to the first side panel; and
 - a second web panel foldably connected to the first web panel, the second web panel being adhered to the first bottom end flap.
5. The carrier package of any one of claims 1 to 4, wherein the at least one handle feature comprises a first handle feature at the first end of the carrier package.
6. The carrier package of claim 5, wherein the first handle feature comprises a first perimeter line of disruption, the first perimeter line of disruption in part defining a first handle section of the first handle feature.
7. The carrier package of claim 6, wherein
 - the free end edge is a first free end edge of the top panel, and

the first handle feature further comprises an intermediate line of disruption in the first handle section, the intermediate line of disruption extending from or adjacent to the first perimeter line of disruption to the first free end edge of the top panel.

8. The carrier package of claim 7, wherein the first handle feature further comprises a cut or score at or adjacent to the first perimeter line of disruption.

9. The carrier package of any one of claims 1 to 8, further comprising a plurality of containers, wherein the plurality of containers comprises at least four generally cylindrical containers.

10. The carrier package of claim 9, wherein the containers are arranged in a two by two arrangement.

11. The carrier package of claim 10, wherein each container has a longitudinal axis, the longitudinal axes of the containers being generally perpendicular to the bottom panel.

12. The carrier package of any one of claims 1 to 11, wherein the first and second side panels taper inwardly towards the top panel.

13. The carrier package of any one of claims 1 to 4, wherein the at least one handle feature comprises a first handle feature at a first free end edge of the top panel and a second handle feature at a second free end edge of the top panel.

14. A method of carrying a carrier package, comprising:
providing a carrier package according to claim 13;
placing at least one finger on the top panel at the first handle feature;
placing at least one finger on the top panel at the second handle feature;
deforming the top panel at the first and second handle features; and
lifting the carrier package.

15. The carrier package of claim 1, wherein the first end is at least partially closed by a first web portion foldably connected to the first side panel, a second web portion foldably connected to the second side panel, and a first bottom end flap foldably connected to the bottom panel, and

the at least one handle feature comprises a first handle feature at a first free end edge of the top panel at the first end of the carrier package and a second handle feature at a second free end edge of the top panel at the second end of the carrier package.

16. The carrier package of claim 15, wherein the first handle feature comprises a first plurality of lines of disruption in the top panel and wherein the first plurality of lines of disruption comprises a first perimeter line of disruption, the first perimeter line of disruption extending at least adjacent to the first free end edge of the top panel.

17. The carrier package of claim 16, wherein the first handle feature further comprises a first intermediate line of disruption extending to the first free end edge of the top panel and a cut or score at or adjacent to the first perimeter line of disruption.

18. The carrier package of claim 15, 16, or 17, wherein the first web portion comprises a first web panel foldably connected to the first side panel, and a second web panel foldably connected to the first web panel, the second web panel being adhered to the first bottom end flap and wherein the first and second side panels taper inwardly towards the top panel.

19. A method of carrying a carrier package, comprising:
 providing a carrier package according to claim 15;
 placing at least one finger on the top panel at the first handle feature;
 placing at least one finger on the top panel at the second handle feature;
 deforming the top panel at the first and second handle features; and
 lifting the carrier package.

20. A blank, comprising:
 a bottom panel;
 a first bottom end flap foldably connected to a first end of the bottom panel;
 a second bottom end flap foldably connected to a second end of the bottom panel;
 a top panel;
 a first side panel;
 a second side panel;
 a first web portion foldably connected to a first end of the first side panel;
 a second web portion foldably connected to a second end of the first side panel; and

a deformable first handle feature positioned along a first free end edge of the top panel, the first handle feature being adapted to allow deformation of the top panel without tearing so that the integrity of the carrier package is maintained.

21. The blank of claim 20, wherein the at least one first line of disruption comprises a first perimeter line of disruption, the first perimeter line of disruption in part defining a first handle section of the first handle feature and extending at least adjacent to the first free end edge of the top panel.

22. The blank of claim 20 or 21, wherein the first handle feature further comprises:
a first intermediate line of disruption in the first handle section and extending to the first free end edge of the top panel; and
a cut or score at or adjacent to the first perimeter line of disruption.

23. The blank of claim 20, 21, or 22, wherein the first web portion comprises:
a first web panel foldably connected to the first side panel; and
a second web panel foldably connected to the first web panel.

24. The blank of any one of claims 20 to 23, wherein the first and second side panels taper inwardly toward to the top panel.

25. The blank of any one of claims 20 to 24, wherein the blank is constructed from paperboard.

26. The carrier package of claim 1, wherein the at least one handle feature comprises a handle section defined by a perimeter fold line in the top panel and an intermediate fold line in the handle section, the perimeter fold line comprising at least one portion that extends substantially to the free end edge of the top panel, the intermediate fold line extending substantially between the perimeter fold line and the free end edge of the top panel, wherein the handle section is operative for being pivoted without tearing along the length of the perimeter fold line.

27. The carrier package of claim 26, wherein
the at least one handle feature further comprises a cut line, and

the at least one portion of the perimeter fold line comprises a first arcuate fold line extending substantially from the cut line to the at least one free end edge and a second arcuate fold line extending substantially from the cut line to the at least one free end edge.

28. The carrier package of claim 15, further comprising a plurality of containers.

29. The carrier package of claim 28, wherein the plurality of containers comprises four containers in a two by two arrangement, each container having a longitudinal axis, the axes of the containers being generally perpendicular to the bottom panel.

30. The blank of claim 20, wherein the first handle feature comprises a handle section defined by a perimeter fold line and an intermediate fold line in the handle section.

31. The blank of claim 30, wherein

the perimeter fold line comprises at least one portion that extends substantially to the first free end edge of the top panel,

the intermediate fold line extends from the perimeter fold line substantially to the first free end edge of the top panel, and

the first handle feature is operative for deforming the top panel without tearing along the length of the perimeter fold line.

1/4

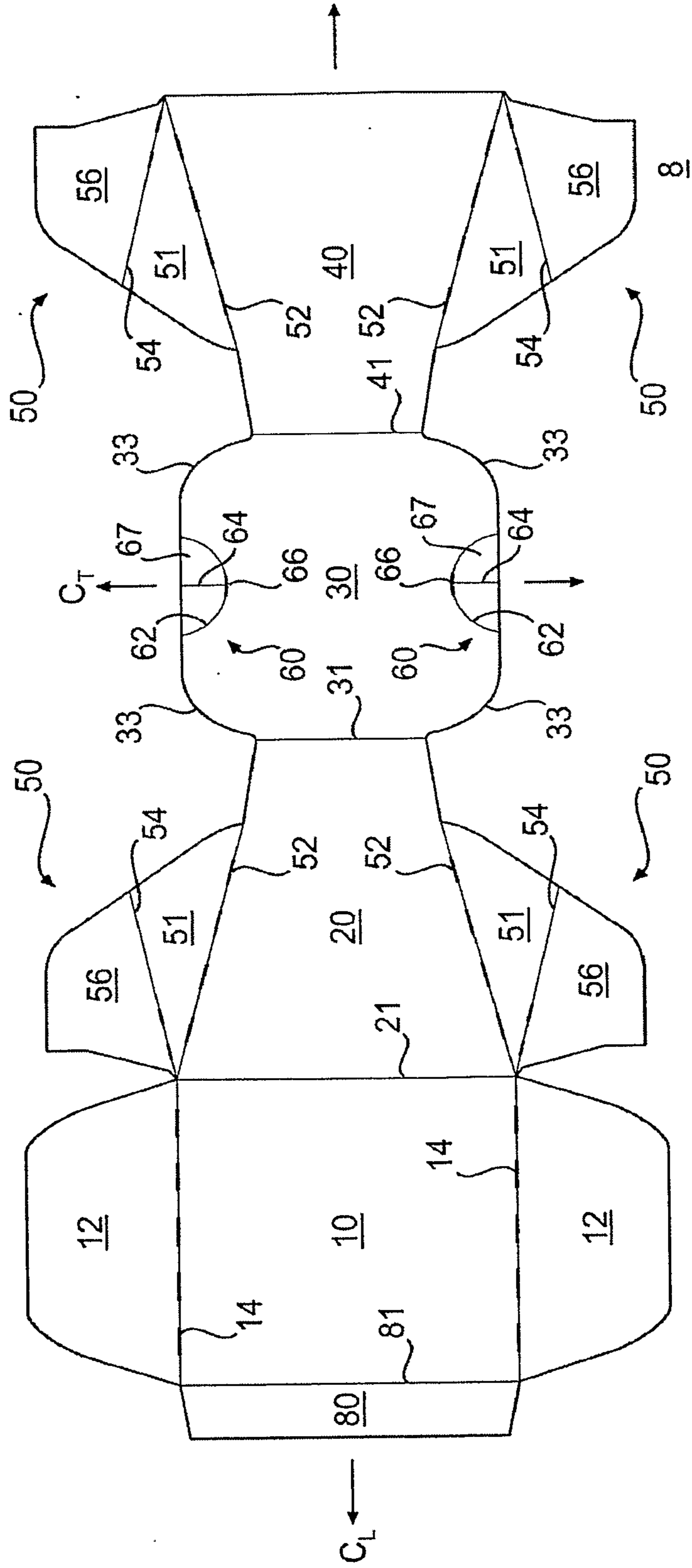

FIG. 1

2/4

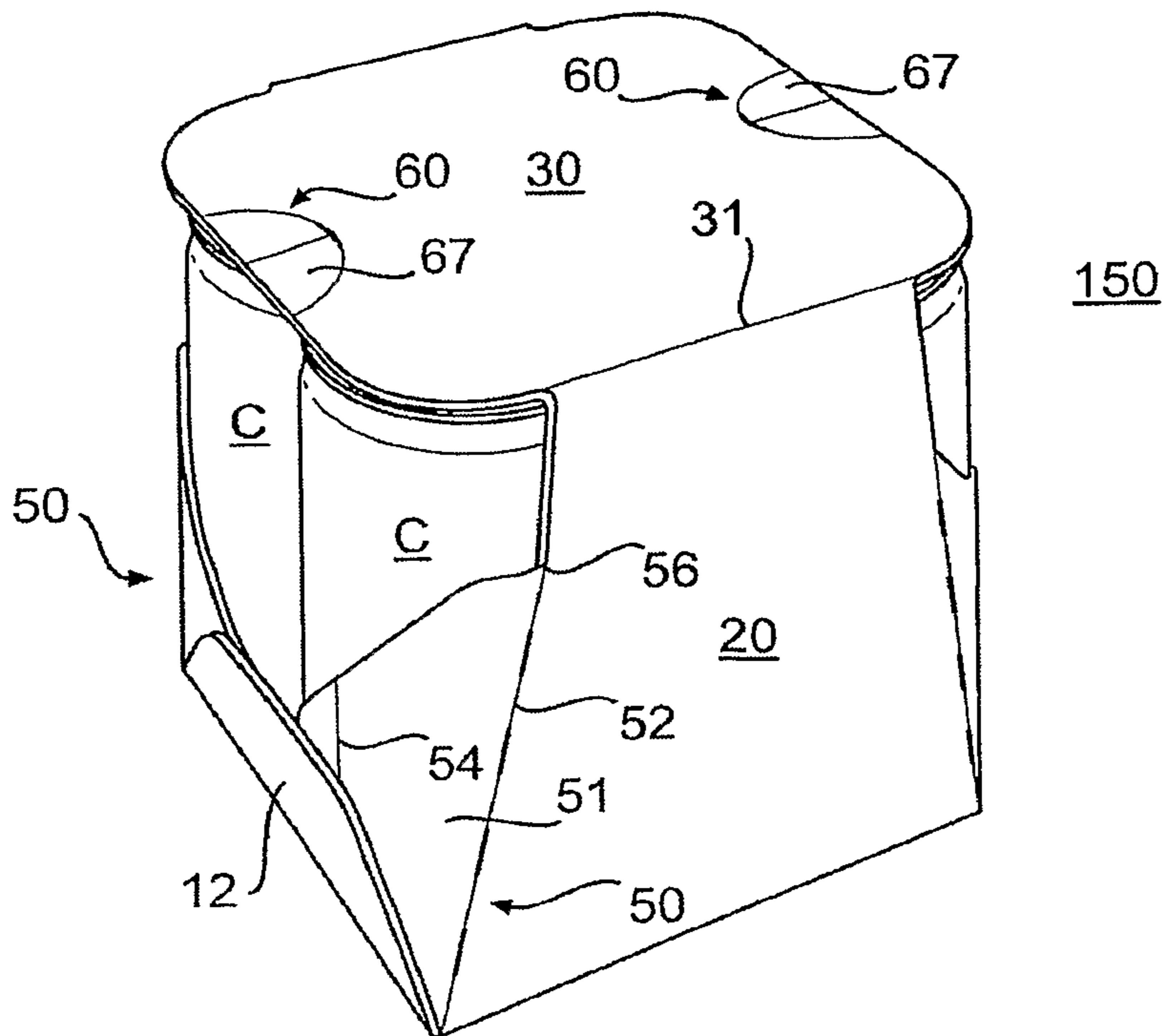

FIG. 2

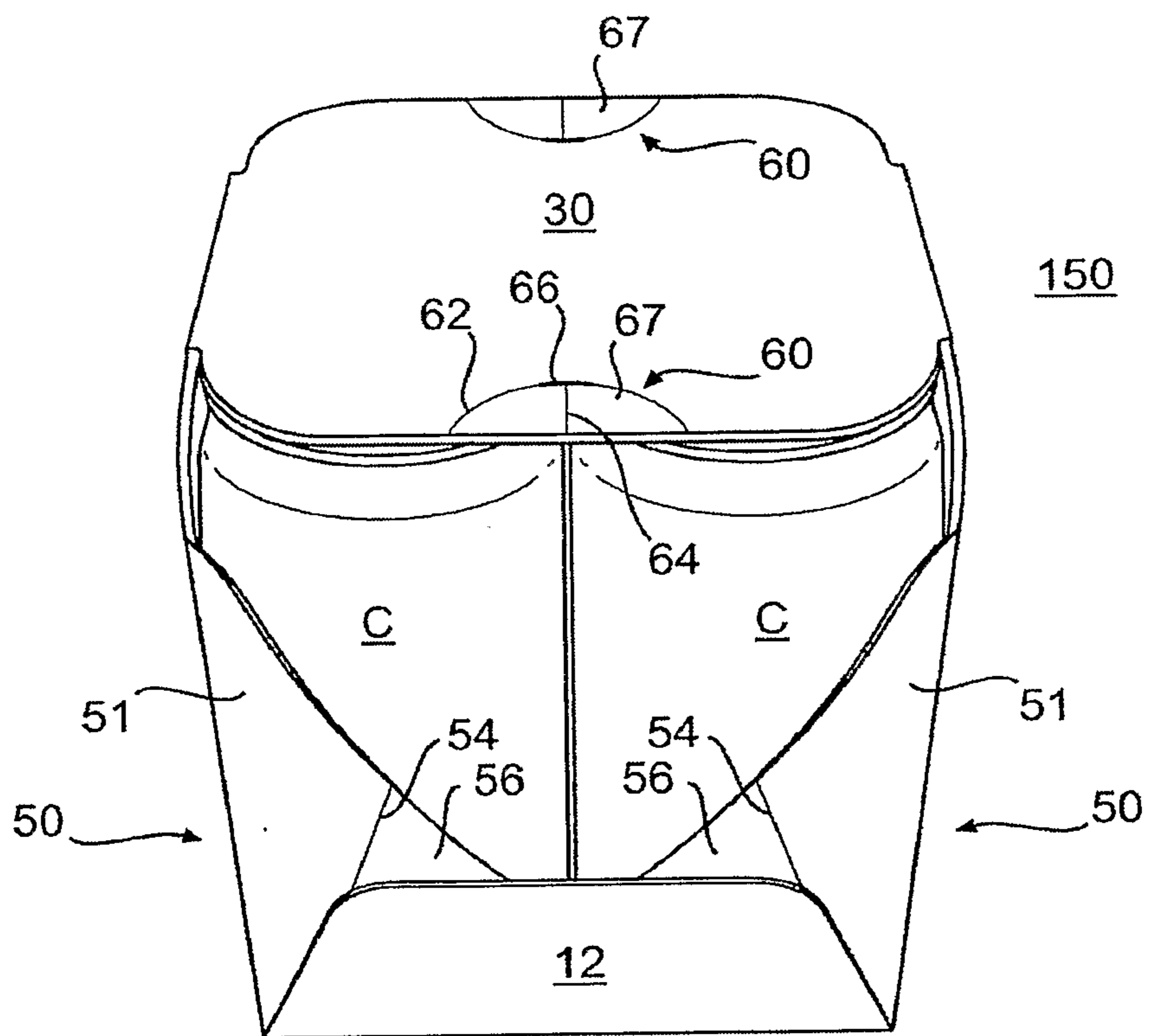

FIG. 3

4/4

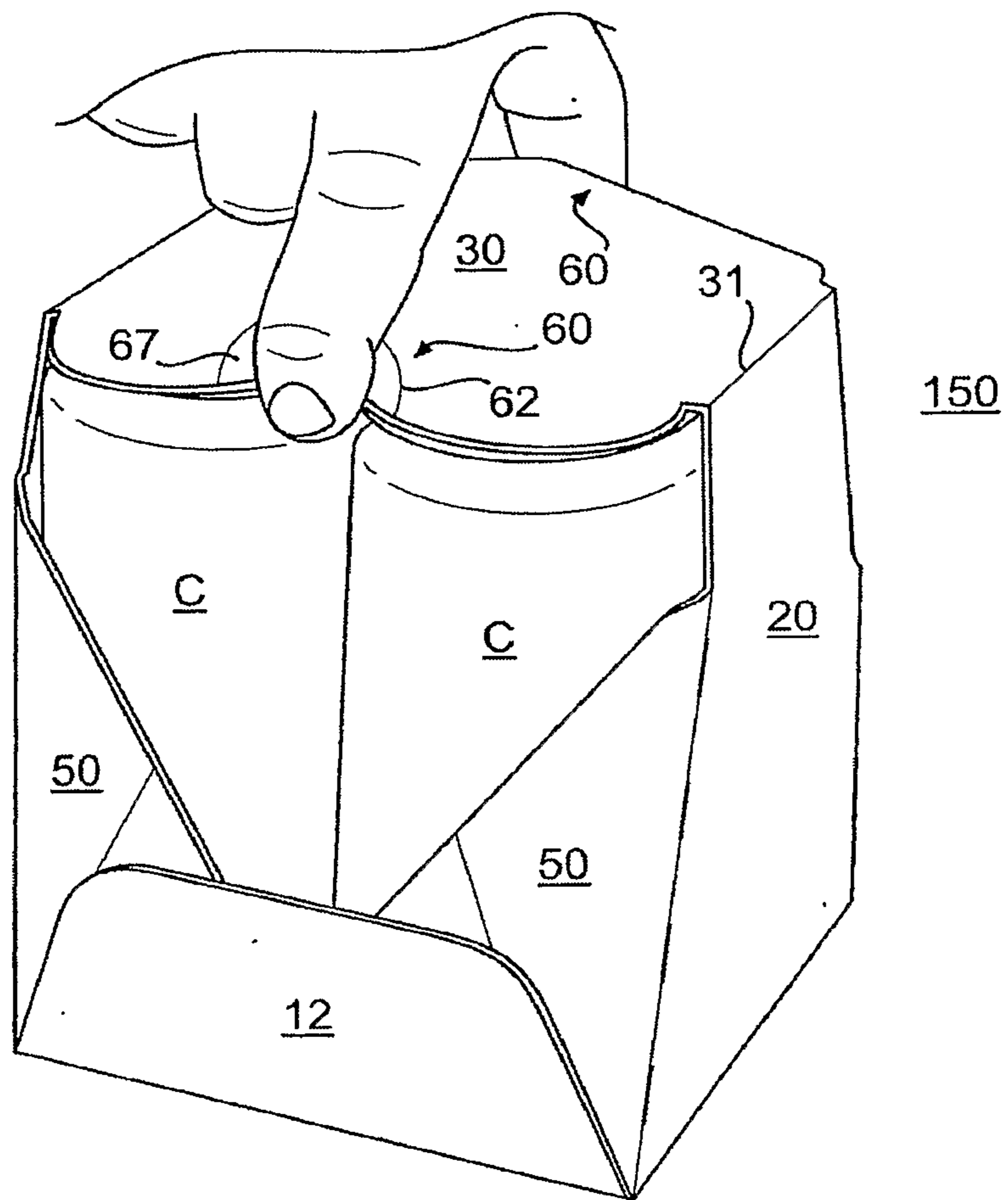

FIG. 5

