



US 20040093088A1

(19) **United States**

(12) **Patent Application Publication**

**Ralph et al.**

(10) **Pub. No.: US 2004/0093088 A1**

(43) **Pub. Date: May 13, 2004**

(54) **INTERVERTEBRAL SPACER DEVICE  
HAVING A SLOTTED PARTIAL CIRCULAR  
DOMED ARCH STRIP SPRING**

(76) Inventors: **James D. Ralph**, Seaside Park, NJ  
(US); **Stephen Tatar**, Montvale, NJ  
(US); **Joseph P. Errico**, Kirkland, WA  
(US)

Correspondence Address:  
**SPINECORE, INC.**  
447 SPRINGFIELD AVENUE  
SUITES W2-W3  
SUMMIT, NJ 07901 (US)

(21) Appl. No.: **10/648,464**

(22) Filed: **Aug. 25, 2003**

**Related U.S. Application Data**

(63) Continuation of application No. 10/035,669, filed on Nov. 9, 2001, now Pat. No. 6,610,092, which is a continuation-in-part of application No. 09/982,148, filed on Oct. 18, 2001, now Pat. No. 6,673,113.

**Publication Classification**

(51) **Int. Cl.<sup>7</sup>** ..... **A61F 2/44**  
(52) **U.S. Cl.** ..... **623/17.14; 623/17.15**

(57) **ABSTRACT**  
An intervertebral spacer device having a pair of opposing plates for seating against opposing vertebral bone surfaces. Each of the opposing plates has an external surface with a deflectable wire mesh thereon, into which the bone can readily grow.

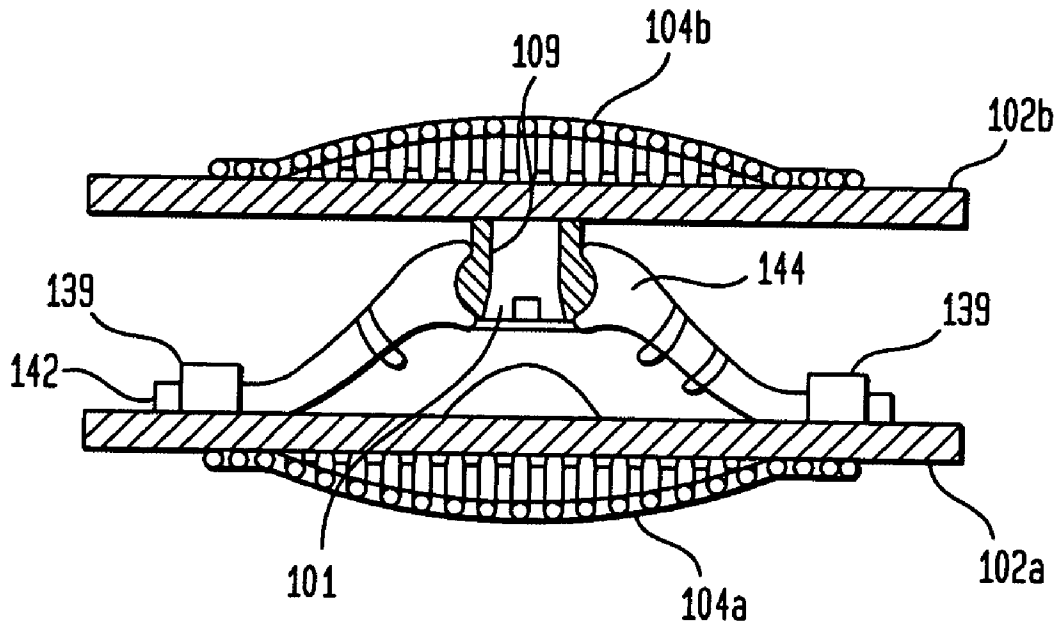

**FIG. 1**  
(PRIOR ART)

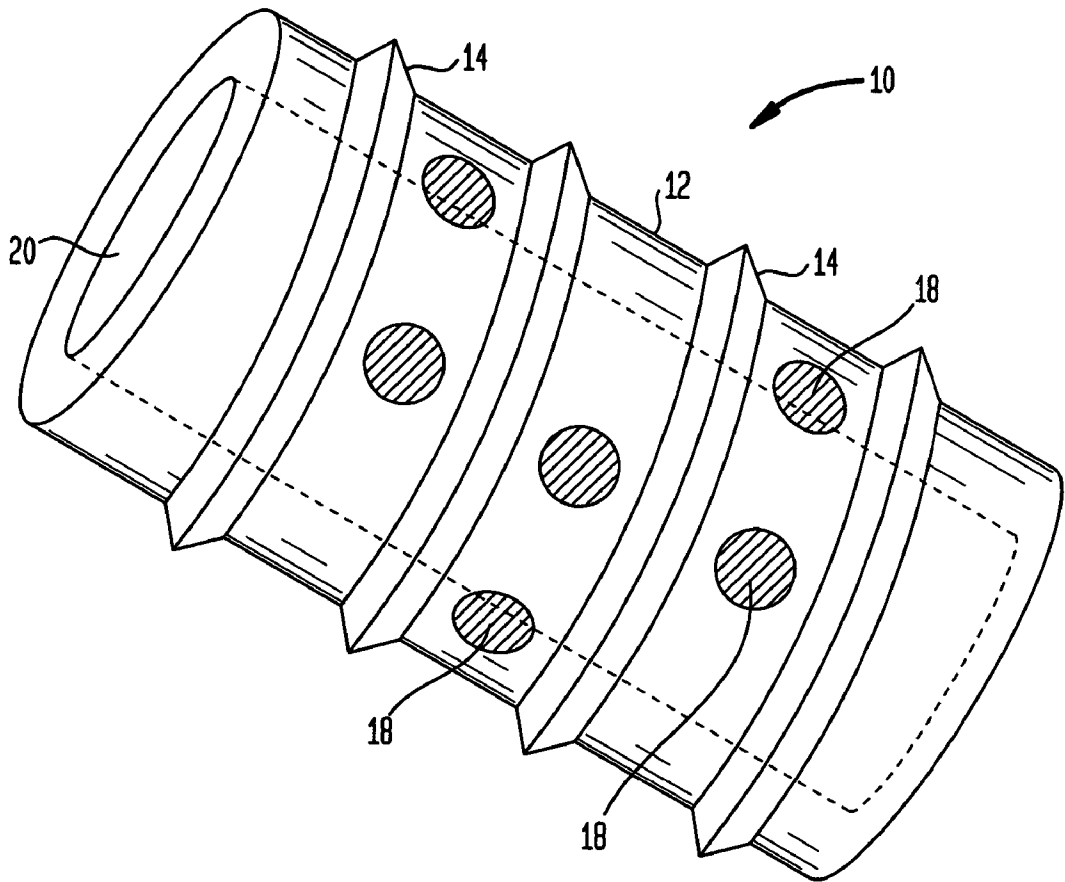

**FIG. 2**  
(PRIOR ART)

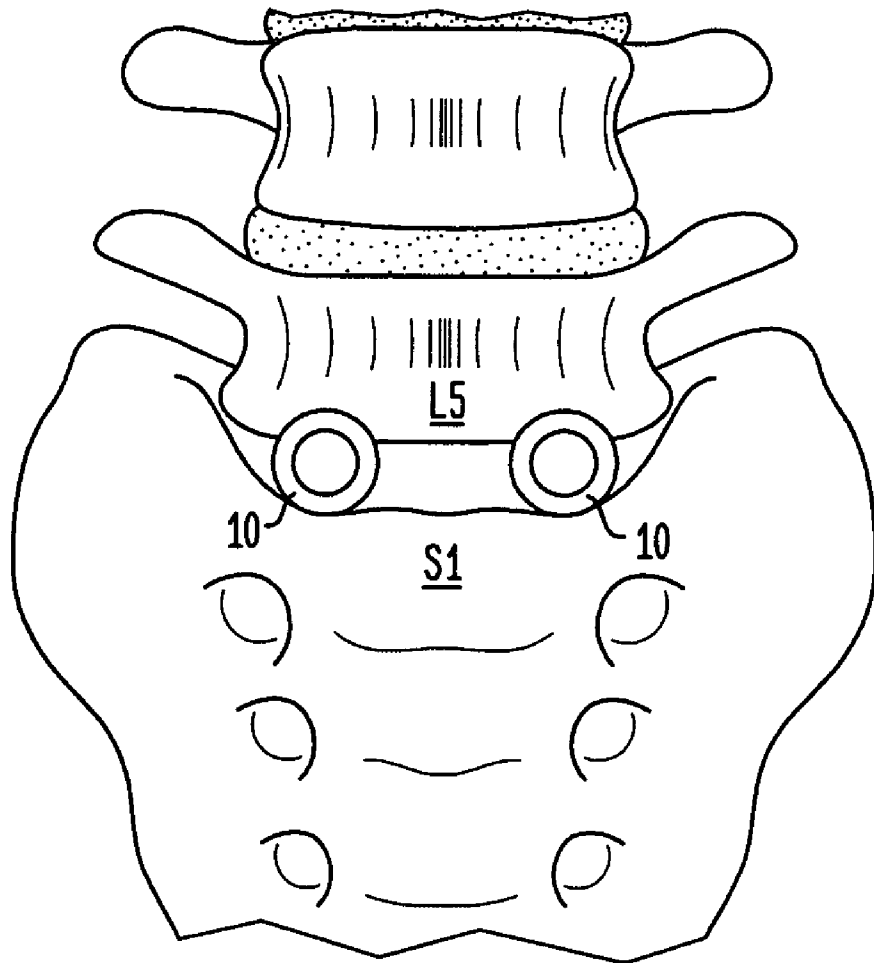

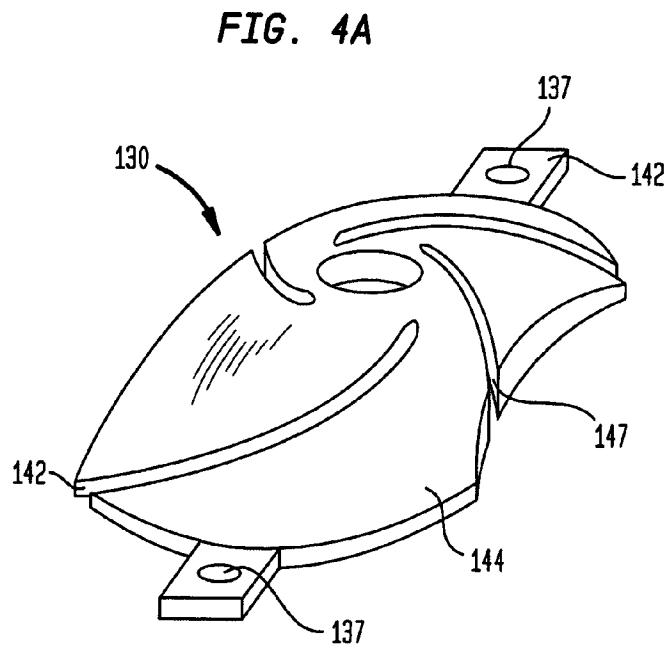
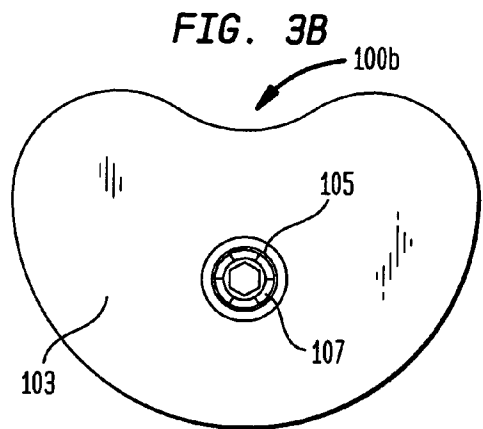
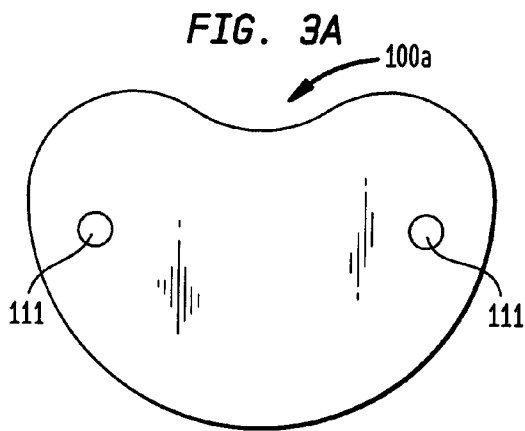

FIG. 4B

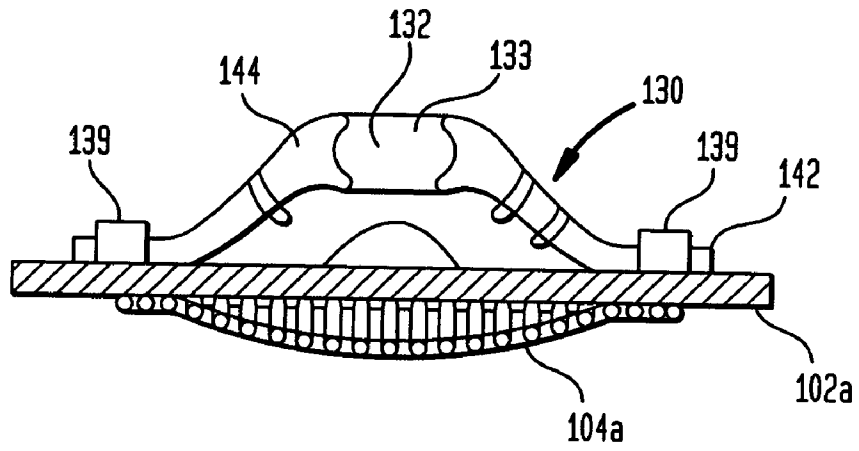
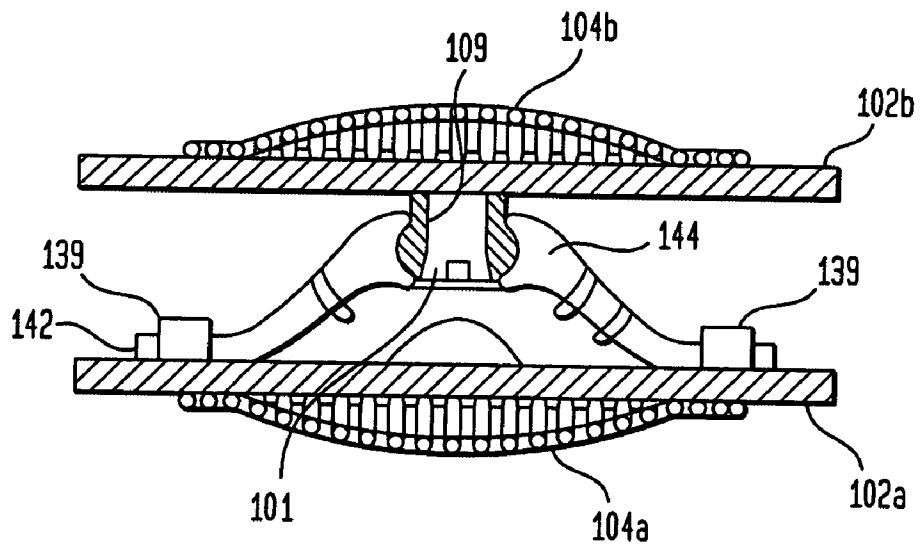

FIG. 5



## INTERVERTEBRAL SPACER DEVICE HAVING A SLOTTED PARTIAL CIRCULAR DOMED ARCH STRIP SPRING

### CROSS-REFERENCE TO RELATED APPLICATION

[0001] This application is a continuing application of U.S. patent application Ser. No. 10/035,669 filed Nov. 9, 2001 and entitled "An Intervertebral Spacer Device Having a Slotted Partial Circular Domed Arch Strip Spring", which is a continuation in part of U.S. patent application Ser. No. 09/982,148 filed Nov. 18, 2001 and entitled "An Intervertebral Spacer Device Having Arch Shaped Spring Elements", both of which are fully incorporated herein by reference.

### FIELD OF THE INVENTION

[0002] This invention relates generally to a spinal implant assembly for implantation into the intervertebral space between adjacent vertebral bones to simultaneously provide stabilization and continued flexibility and proper anatomical motion.

### BACKGROUND OF THE INVENTION

[0003] The bones and connective tissue of an adult human spinal column consists of more than 20 discrete bones coupled sequentially to one another by a tri-joint complex which consists of an anterior disc and the two posterior facet joints, the anterior discs of adjacent bones being cushioned by cartilage spacers referred to as intervertebral discs. These more than 20 bones are anatomically categorized as being members of one of four classifications: cervical, thoracic, lumbar, or sacral. The cervical portion of the spine, which comprises the top of the spine, up to the base of the skull, includes the first 7 vertebrae. The intermediate 12 bones are the thoracic vertebrae, and connect to the lower spine comprising the 5 lumbar vertebrae. The base of the spine is the sacral bones (including the coccyx). The component bones of the cervical spine are generally smaller than those of the thoracic spine, which are in turn smaller than those of the lumbar region. The sacral region connects laterally to the pelvis. While the sacral region is an integral part of the spine, for the purposes of fusion surgeries and for this disclosure, the word spine shall refer only to the cervical, thoracic, and lumbar regions.

[0004] The spinal column of bones is highly complex in that it includes over twenty bones coupled to one another, housing and protecting critical elements of the nervous system having innumerable peripheral nerves and circulatory bodies in close proximity. In spite of these complications, the spine is a highly flexible structure, capable of a high degree of curvature and twist in nearly every direction.

[0005] Genetic or developmental irregularities, trauma, chronic stress, tumors, and degenerative wear are a few of the causes which can result in spinal pathologies for which surgical intervention may be necessary. A variety of systems have been disclosed in the art which achieve immobilization and/or fusion of adjacent bones by implanting artificial assemblies in or on the spinal column. The region of the back which needs to be immobilized, as well as the individual variations in anatomy, determine the appropriate surgical protocol and implantation assembly. With respect to

the failure of the intervertebral disc, the interbody fusion cage has generated substantial interest because it can be implanted laparoscopically into the anterior of the spine, thus reducing operating room time, patient recovery time, and scarification.

[0006] Referring now to **FIGS. 1 and 2**, in which a side perspective view of an intervertebral body cage and an anterior perspective view of a post implantation spinal column are shown, respectively, a more complete description of these devices of the prior art is herein provided. These cages **10** generally comprise tubular metal body **12** having an external surface threading **14**. They are inserted transverse to the axis of the spine **16**, into preformed cylindrical holes at the junction of adjacent vertebral bodies (in **FIG. 2** the pair of cages **10** are inserted between the fifth lumbar vertebra (L5) and the top of the sacrum (S1). Two cages **10** are generally inserted side by side with the external threading **14** tapping into the lower surface of the vertebral bone above (L5), and the upper surface of the vertebral bone (S1) below. The cages **10** include holes **18** through which the adjacent bones are to grow. Additional material, for example autogenous bone graft materials, may be inserted into the hollow interior **20** of the cage **10** to incite or accelerate the growth of the bone into the cage. End caps (not shown) are often utilized to hold the bone graft material within the cage **10**.

[0007] These cages of the prior art have enjoyed medical success in promoting fusion and grossly approximating proper disc height. It is, however, important to note that the fusion of the adjacent bones is an incomplete solution to the underlying pathology as it does not cure the ailment, but rather simply masks the pathology under a stabilizing bridge of bone. This bone fusion limits the overall flexibility of the spinal column and artificially constrains the normal motion of the patient. This constraint can cause collateral injury to the patient's spine as additional stresses of motion, normally borne by the now-fused joint, are transferred onto the nearby facet joints and intervertebral discs. It would therefore, be a considerable advance in the art to provide an implant assembly which does not promote fusion, but, rather, which nearly completely mimics the biomechanical action of the natural disc cartilage, thereby permitting continued normal motion and stress distribution.

[0008] It is, therefore, an object of the present invention to provide a new and novel intervertebral spacer which stabilizes the spine without promoting a bone fusion across the intervertebral space.

[0009] It is further an object of the present invention to provide an implant device which stabilizes the spine while still permitting normal motion.

[0010] It is further an object of the present invention to provide a device for implantation into the intervertebral space which does not promote the abnormal distribution of biomechanical stresses on the patient's spine.

[0011] Other objects of the present invention not explicitly stated will be set forth and will be more clearly understood in conjunction with the descriptions of the preferred embodiments disclosed hereafter.

### SUMMARY OF THE INVENTION

[0012] The preceding objects of the invention are achieved by the present invention which is a flexible intervertebral

spacer device comprising a pair of spaced apart base plates, arranged in a substantially parallel planar alignment (or slightly offset relative to one another in accordance with proper lordotic angulation) and coupled to one another by means of at least one spring mechanism. This at least one spring mechanism provides a strong restoring force when a compressive load is applied to the plates, and may also permit limited rotation of the two plates relative to one another. While there are a wide variety of embodiments contemplated, one preferred embodiment is described herein as representative of preferred types.

[0013] More particularly, with respect to the base plates, which are largely similar in all embodiments, as the assembly is to be positioned between the facing surfaces of adjacent vertebral bodies, and as such need to have substantially flat external surfaces which seat against the opposing bone surfaces. Inasmuch as these bone surfaces are often concave, it is anticipated that the opposing plates may be convex in accordance with the average topology of the spinal anatomy. In addition, the plates are to mate with the bone surfaces in such a way as to not rotate relative thereto. (The plates rotate relative to one another, but not with respect to the bone surfaces to which they are each in contact with.) In order to prevent rotation of a plate relative to the bone, the upper and lower plates alternatively may each include outwardly directed spikes or ridges which penetrate the bone surface and mechanically hold the plates in place. However, it is more preferably anticipated that the plates should include a porous coating into which the bone of the vertebral body can grow. The most desirable upper and lower plate surface porous feature is a deflectable wire mesh into which the bone can readily grow, and which mesh will deform to seat into the concave upper and lower bone faces. (Note that this limited fusion of the bone to the base plate does not extend across the intervertebral space.) These features, while being preferred are not required.

[0014] Between the base plates, on the exterior of the device, there may also be included a circumferential wall which is resilient and which simply prevents vessels and tissues from entering within the interior of the device. This resilient wall may comprise a porous fabric or a semi-impermeable elastomeric material. Suitable tissue compatible materials meeting the simple mechanical requirements of flexibility and durability are prevalent in a number of medical fields including cardiovascular medicine, wherein such materials are utilized for venous and arterial wall repair, or for use with artificial valve replacements. Alternatively, suitable plastic materials are utilized in the surgical repair of gross damage to muscles and organs. Still further materials which could be utilized herein may be found in the field of orthopedic in conjunction with ligament and tendon repair. It is anticipated that future developments in this area will produce materials which are compatible for use with this invention, the breadth of which shall not be limited by the choice of such a material. For the purposes of this description, however, it shall be understood that such a circumferential wall is unnecessary, and in some instances may be a hindrance, and thusly is not included in the specific embodiment set forth hereinbelow.

[0015] As introduced above, the internal structure of the present invention comprises a spring member, or other equivalent subassembly which provides a restoring force when compressed. It is desirable that the restoring forces be

directed outward against the opposing plates, when a compressive load is applied to the plates. More particularly, the restoring force providing subassembly comprises a circular slotted arch-shaped metal spring which is secured to the lower plate and against movement therefrom at its lateral ends. The slotted arched pieces of metal comprise continuous flat ends disposed at the circumferential edge, and a slotted curvate central portion. The curvate central portion is curvate in two axes, and shall hereinafter be termed a partial circular domed arch. The central portion is curved along the long axis (the length) of the strip into an upside down U-shape. The central portion is further curved in the lateral direction (the width of the strip) such that the outer surface (the top of the upside down U-shape) is convex. Stated alternatively, the central curvate portion of the metal strip comprises a section of a hemispheric shell (or paraboloid, or other suitable geometric shape) which has been cut along two minor arcs which are parallel to, but on opposing sides of a diameter (great circles) of the surface. In the preferred embodiment described herein, the majority of the hemispheric shell remains intact, having only spiral slots formed therein.

[0016] The slots formed in the curvate portion extend along the length of the strip from the junction with the flat lateral ends up to points near to the peak of the partial circular domed arch. These slots permit the spring to deflect more easily than a continuous structure, thus permitting the design to more nearly approximate the loading profile of naturally occurring intervertebral disc cartilage.

[0017] More particularly, the slotted partial circular domed arch portions of the strips deflect under loading, but provide a restoring force in opposition to the loading until they are permitted to regain their original shape. The restoring force of an arched strip of metal is proportional to the elastic properties of the material as well as the length and arc of the curvate central portion of the strip. The elasticity of the metal, which endures and counteracts the strain of the material, causes a deflection in the height of the arch.

[0018] In the preferred embodiment, the peak of the slotted partial circular domed arch further comprises a socket for flexibly coupling to a post member on the interior surface of the opposing plate. This socket is formed at the center of the central portion, which is an unslotted region. This post couples to the spring to form a ball and socket joint at the peak of the partial circular domed arch, which joint permits the plates to rotate relative to one another. This rotation may be constrained by the specific confirmation of the joint such that the plates are free to rotate through only a range of angles.

[0019] More particularly, this embodiment comprises a pair of spaced apart base plates, one of which includes means for coupling the flat lateral ends of the domed arched spring thereto (such as simple set screws). The other of the plates is similarly shaped, having a flat exterior surface (which may include a mesh or porous coating to permit bony in growth), but further includes a short central post portion which rises out of the interior face at a nearly perpendicular angle. The top of this short post portion includes a ball-shaped knob. The knob includes a central threaded axial bore which receives a small set screw. Prior to the insertion of the set screw, the ball-shaped head of the post can deflect

radially inward (so that the ball-shaped knob contracts). The insertion of the set screw eliminates the capacity for this deflection.

[0020] As introduced above, the slotted domed arch spring is mounted to this ball-shaped knob in such a way that it may rotate freely through a range of angles equivalent to the fraction of normal human spine rotation (to mimic normal disc rotation). In order to couple with the post, the strip spring includes a socket which accommodates the ball-shaped portion of the post. More particularly, the socket includes a curvate volume having a substantially constant radius of curvature which is also substantially equivalent to the radius of the ballshaped head of the post. The deflectability of the ball-shaped head of the post, prior to the insertion of the set screw, permits the head to be inserted into the interior volume at the center of the spring, and the washer to be rotated into the proper lordotic angulation. Subsequent introduction of the set screw into the axial bore of the post flexibly retains the head in the socket of the strip spring. This assembly provides ample spring-like performance with respect to axial compressive loads, as well as long cycle life to mimic the axial biomechanical performance of the normal human intervertebral disc.

#### BRIEF DESCRIPTION OF THE DRAWINGS

[0021] FIG. 1 is a side perspective view of an interbody fusion device of the prior art;

[0022] FIG. 2 is a front view of the anterior portion of the lumbo-sacral region of a human spine, into which a pair of interbody fusion devices of the type shown in FIG. 1 have been implanted;

[0023] FIGS. 3a and 3b are top views of the upper and lower opposing plates of one embodiment of the present invention;

[0024] FIGS. 4a and 4b are a side perspective view and a cross section view of a lower plate having a slotted partial circular domed arch-shaped strip spring including a central socket mounted thereto it; and

[0025] FIG. 5 is a side cross-section view of a second embodiment of the present invention which utilizes the elements shown in FIGS. 3a, 3b, 4a, and 4b.

#### DETAILED DESCRIPTION OF THE PREFERRED EMBODIMENT

[0026] While the present invention will be described more fully hereinafter with reference to the accompanying drawings, in which particular embodiments and methods of implantation are shown, it is to be understood at the outset that persons skilled in the art may modify the invention herein described while achieving the functions and results of this invention. Accordingly, the descriptions which follow are to be understood as illustrative and exemplary of specific structures, aspects and features within the broad scope of the present invention and not as limiting of such broad scope. Like numbers refer to similar features of like elements throughout.

[0027] Referring now to FIGS. 3a and 3b, side cross-section views of the top and bottom plate members 100a 100b of a first embodiment of the present invention are shown. More particularly, in this embodiment, the upper and

lower plates 100a,100b are nearly identical. As the device is designed to be positioned between the facing surfaces of adjacent vertebral bodies, the plates include substantially flat surface portions 102a,102b which seat against the opposing bone surfaces. In addition, the plates are to mate with the bone surfaces in such a way as to not rotate relative thereto. It is, therefore, preferred that the plates should include a porous coating into which the bone of the vertebral body can grow. The most desirable upper and lower plate surface porous feature is a deflectable wire mesh into which the bone can readily grow, and which mesh 104a,104b (see FIGS. 4b and 5) will deform to seat into the concave upper and lower bone faces. (Note that this limited fusion of the bone to the base plate does not extend across the intervertebral space.)

[0028] Plate 100a further includes a single set of threaded holes 111 for receiving the set screws (shown in FIGS. 4a and 4b) required to affix the lateral ends of the domed arch strip spring thereto it.

[0029] Plate 100b has a similar shaped to the plates described above, i.e., having a flat exterior surface 102b which is designed to seat against the exposed opposing bone face in an intervertebral space, but plate 100b further includes a short central post member 105 which rises out of the interior face 103 at a nearly perpendicular angle. The top of this short post member 105 includes a ball-shaped head 107. The head 107 includes a central threaded axial bore 109 which extends down the post 105. This threaded bore 109 is designed to receive a small set screw 101. Prior to the insertion of the set screw 101, the ball-shaped head 107 of the post 105 can deflect radially inward (so that the ball-shaped head contracts). The insertion of the set screw 101 eliminates the capacity for this deflection.

[0030] Referring now to FIGS. 4a and 4b, the partial circular domed slotted arch strip spring 130 of this embodiment is shown in a side view and a cross-section view, respectively. As introduced above, the domed strip of metal comprise flat ends 142 and a partially circular domed central portion 144. The central portion 144 is curvate in two axes, and shall hereinafter be termed a domed arch 144. The central portion 144 is curved along the long axis (the length of the strip) of the strip into an upside down U-shape. The central portion 144 is further curved in the lateral direction (the width of the strip) such that the outer surface (the top of the upside down U-shape) is convex. Stated alternatively, the central curvate portion 144 of the metal strip comprises a section of a hemispheric shell (or paraboloid, or other suitable geometric shape) which has been cut along two minor arcs which are parallel to, but on opposing sides of a diameter (great circles) of the surface (thus removing two lateral edges of the domed shell).

[0031] The lateral ends 142 of the slotted domed arch springs include holes 137 through which set screws 139 may be introduced therethrough and into the set screw holes 111 in the plate 100a to secure the spring 130 to the plate. The slots 147 of the partial circular slotted domed arch spring 130 are provided to render the springs more deflectable, thus mimicking the natural behavior of the cartilage of the human intervertebral disc. The slots 147 are spirally disposed in the disc extending from the lateral edges of the central domed portion 144 to points which are out from the central hole 132 in the spring.

[0032] This partial circular domed arch strip spring 130 further includes the additional feature of having an enlarged



central opening **132**. This central opening **132** includes a curvate volume **133** for receiving therein the ball-shaped head **107** of the post **105** of the lower plate **100b** described above. More particularly, the curvate volume **133** has a substantially constant radius of curvature which is also substantially equivalent to the radius of the ball-shaped head **107** of the post **105**.

[0033] Referring also to **FIG. 5**, in which the fully assembled second embodiment of the present invention is shown, the combination and assembly of this embodiment is now provided. The deflectability of the ball-shaped head **107** of the post **105**, prior to the insertion of the set screw **101**, permits the head **107** to be inserted into the interior volume **133** at the peak of the slotted domed arch strip spring **130**. Subsequent introduction of the set screw **101** into the axial bore **109** of the post **101** flexibly couples the head **107** to the spring **130** by virtue of the head **107** not being compressible and removable from the central volume **133**, but the post **105** being polyaxially retained in the socket **133**. Ideally the post head **107** is locked loosely enough within the central volume **133** of the spring **130** such that anatomically relevant rotation of the plates **100a,100b** remains viable. In alternative variation, however, it is possible to design the coupling such that the locking of the set screw **101** in the head **107** locks the assembly in one rotational orientation, preventing free rotation of the plates relative to one another. A combined embodiment may be one in which the set screw **101** may be selectively positioned in an unlocked (but still securing for the purpose of retention) and a locked orientation.

[0034] While there has been described and illustrated embodiments of an intervertebral spacer device, it will be apparent to those skilled in the art that variations and modifications are possible without deviating from the broad spirit and principle of the present invention. The present invention shall, therefore, not be limited solely to the specific embodiments disclosed herein.

We claim:

1. An intervertebral spacer device, comprising:
  - first and second plate members, each having an external plate surface thereof, the plate members being disposed such that the external plate surfaces face in opposite directions, at least one of the external plate surfaces having a mesh thereon.
  2. The device as set forth in claim 1, wherein an inner surface of the second plate member further comprises a ball-shaped structure extending therefrom.
  3. The device as set forth in claim 2, wherein an inner surface of the first plate member comprises a curvate volume for receiving and holding therein the ball-shaped structure.
  4. The device as set forth in claim 1, wherein the mesh is deflectable.
  5. The device as set forth in claim 1, wherein the mesh is convex.
  6. The device as set forth in claim 5, wherein the mesh is deflectable.
7. An intervertebral spacer device, comprising:
  - first and second plate members, each having an external plate surface thereof, the plate members being disposed such that the external plate surfaces face in opposite directions, at least one of the external plate surfaces having a convex porous surface thereon.
  8. The device as set forth in claim 7, wherein an inner surface of the second plate member further comprises a ball-shaped structure extending therefrom.
  9. The device as set forth in claim 8, wherein an inner surface of the first plate member comprises a curvate volume for receiving and holding therein the ball-shaped structure.
  10. The device as set forth in claim 7, wherein the convex porous surface is deflectable.
  11. The device as set forth in claim 7, wherein the convex porous surface comprises a wire mesh.
  12. The device as set forth in claim 7, wherein the convex porous surface comprises a deflectable wire mesh.

\* \* \* \* \*