



US00D704841S

(12) **United States Design Patent**
Ritchey et al.

(10) **Patent No.:** **US D704,841 S**

(45) **Date of Patent:** **** *May 13, 2014**

(54) **LANDMARK IDENTIFIER FOR TARGETING AN ORTHOPAEDIC IMPLANT**

4,621,628 A 11/1986 Brudermann
D297,047 S 8/1988 Hon et al.
4,794,930 A 1/1989 Machida et al.

(Continued)

(71) Applicant: **Smith & Nephew, Inc.**, Memphis, TN (US)

(72) Inventors: **Nicholas S. Ritchey**, Collierville, TN (US); **Gary F. Prokop**, Wheaton, IL (US); **Adam M. Ruggles**, Columbus, OH (US)

(73) Assignee: **Smith & Nephew, Inc.**, Memphis, TN (US)

(*) Notice: This patent is subject to a terminal disclaimer.

(**) Term: **14 Years**

(21) Appl. No.: **29/434,854**

(22) Filed: **Oct. 17, 2012**

Related U.S. Application Data

(63) Continuation of application No. 12/547,719, filed on Aug. 26, 2009, now Pat. No. 8,086,734.

(51) **LOC (10) Cl.** **24-00**

(52) **U.S. Cl.**
USPC **D24/171**

(58) **Field of Classification Search**
USPC D24/171, 155, 158, 187; 606/96-98;
600/424, 426, 407

See application file for complete search history.

(56) **References Cited**

U.S. PATENT DOCUMENTS

3,219,969 A 11/1965 Snaveley
4,353,110 A 10/1982 Ellis
4,532,599 A 7/1985 Smith

FOREIGN PATENT DOCUMENTS

CA 2571508 A1 12/2006
CN 2698283 Y 5/2005

(Continued)

OTHER PUBLICATIONS

“Guiding Star with the Lidis module,” Ekliptik, 2007.

(Continued)

Primary Examiner — Robert M Spear

Assistant Examiner — Rhea Shields

(74) *Attorney, Agent, or Firm* — Fish & Richardson P.C.

(57) **CLAIM**

The ornamental design for a landmark identifier for targeting an orthopaedic implant, as shown and described.

DESCRIPTION

FIG. 1 is a perspective view of an implementation of a landmark identifier for targeting an orthopaedic implant, showing our new design.

FIG. 2 is a side view of the design of FIG. 1.

FIG. 3 is a front view of the design of FIG. 1.

FIG. 4 is a perspective view of another implementation of our new design.

FIG. 5 is a side view of the design of FIG. 4; and,

FIG. 6 is a front view of the design of FIG. 4.

The broken lines in the figures illustrate unclaimed environment only and form no part of the claimed design. The rear of the article forms no part of the claimed design.

1 Claim, 6 Drawing Sheets

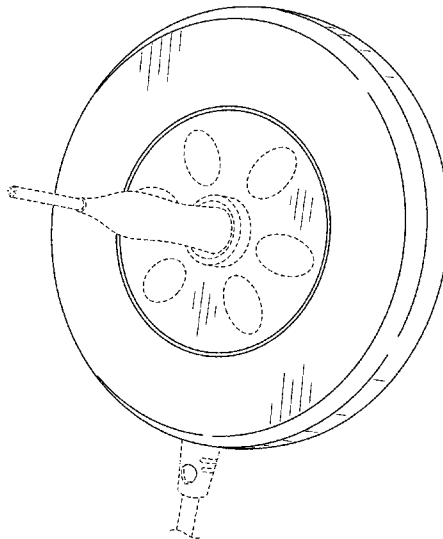
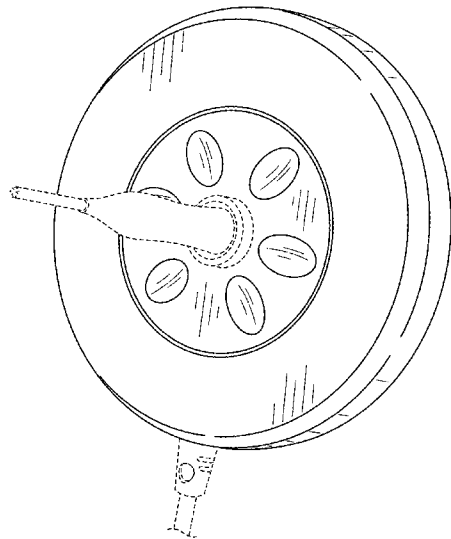

(56)

References Cited

U.S. PATENT DOCUMENTS

4,803,976 A	2/1989	Frigg et al.	2005/0027301 A1	2/2005	Stihl
5,049,151 A	9/1991	Durham et al.	2005/0027304 A1	2/2005	Leloup et al.
5,127,913 A	7/1992	Thomas	2005/0035115 A1	2/2005	Anderson et al.
5,217,009 A	6/1993	Kronberg	2005/0035116 A1	2/2005	Brown et al.
5,281,224 A	1/1994	Faccioli et al.	2005/0043726 A1	2/2005	McHale et al.
5,361,766 A	11/1994	Nichols et al.	2005/0059885 A1	3/2005	Melkent et al.
5,383,917 A	1/1995	Desai et al.	2005/0070916 A1	3/2005	Hollstien et al.
5,411,503 A	5/1995	Hollstien et al.	2005/0075562 A1	4/2005	Szakelyhidi et al.
5,417,688 A	5/1995	Elstrom et al.	2005/0075632 A1	4/2005	Russell et al.
5,433,720 A	7/1995	Faccioli et al.	2005/0080335 A1	4/2005	Simon et al.
5,514,145 A	5/1996	Durham et al.	2005/0080427 A1	4/2005	Govari et al.
5,580,156 A	12/1996	Suzuki et al.	2005/0085714 A1	4/2005	Foley et al.
5,584,838 A	12/1996	Rona et al.	2005/0085715 A1	4/2005	Dukesherer et al.
5,585,783 A	12/1996	Hall	2005/0099290 A1	5/2005	Govari
5,957,836 A	9/1999	Johnson	2005/0124988 A1	6/2005	Terrill et al.
5,957,934 A	9/1999	Rapoport	2005/0143726 A1	6/2005	Bortkiewicz
6,009,878 A	1/2000	Weijand et al.	2005/0197569 A1	9/2005	McCombs
6,036,696 A	3/2000	Lambrecht et al.	2005/0228270 A1	10/2005	Lloyd et al.
6,039,742 A	3/2000	Krettek et al.	2005/0242087 A1	11/2005	Anderson et al.
6,081,741 A	6/2000	Hollis	2005/0245821 A1	11/2005	Govari et al.
6,157,853 A	12/2000	Blume et al.	2005/0261700 A1	11/2005	Tuma et al.
6,162,228 A	12/2000	Durham	2006/0015031 A1	1/2006	Kienzle
6,174,335 B1	1/2001	Varieur et al.	2006/0029186 A1	2/2006	De Villiers et al.
6,212,419 B1	4/2001	Blume et al.	2006/0052782 A1	3/2006	Morgan et al.
6,233,490 B1	5/2001	Kasevich	2006/0074405 A1	4/2006	Malackowski et al.
6,267,770 B1	7/2001	Truwit	2006/0106400 A1	5/2006	Fernandez et al.
6,304,091 B1	10/2001	Shahoian et al.	2006/0142656 A1	6/2006	Malackowski et al.
6,311,082 B1	10/2001	Creighton et al.	2006/0293593 A1	12/2006	Govari et al.
6,474,341 B1	11/2002	Hunter et al.	2007/0093709 A1	4/2007	Abernathie
6,503,249 B1	1/2003	Krause	2007/0129629 A1	6/2007	Beauregard et al.
6,636,757 B1	10/2003	Jascob et al.	2007/0162018 A1	7/2007	Jensen et al.
6,675,491 B2	1/2004	Ooyama et al.	2007/0167744 A1	7/2007	Beauregard et al.
6,694,168 B2	2/2004	Traxel et al.	2007/0191827 A1	8/2007	Lischinsky et al.
6,718,194 B2	4/2004	Kienzle	2007/0208251 A1	9/2007	Anderson et al.
6,747,253 B1	6/2004	Firth et al.	2007/0225595 A1	9/2007	Malackowski et al.
6,807,446 B2	10/2004	Fenn et al.	2007/0255132 A1	11/2007	Shalgi et al.
6,890,332 B2	5/2005	Truckai et al.	2007/0276370 A1	11/2007	Altarac et al.
7,001,346 B2	2/2006	White	2007/0282440 A1	12/2007	Visentin
7,029,478 B2	4/2006	Hollstien et al.	2008/0039857 A1	2/2008	Giersch et al.
7,060,075 B2	6/2006	Govari et al.	2008/0086145 A1	4/2008	Sherman et al.
D528,211 S	9/2006	Solar et al.	2008/0221628 A1	9/2008	Milbocker et al.
7,130,676 B2	10/2006	Barrick	2008/0228195 A1	9/2008	von Jako et al.
7,152,608 B2	12/2006	Hunter et al.	2008/0255560 A1	10/2008	Myers et al.
7,217,276 B2	5/2007	Henderson et al.	2008/0269596 A1	10/2008	Revie et al.
7,294,133 B2	11/2007	Zink et al.	2008/0281326 A1	11/2008	Watanabe et al.
7,295,184 B2	11/2007	Suprun et al.	2008/0281334 A1	11/2008	Zheng et al.
7,358,481 B2	4/2008	Yeoh et al.	2009/0024023 A1	1/2009	Welches et al.
7,477,926 B2	1/2009	McCombs	2009/0054910 A1	2/2009	Zheng et al.
7,532,997 B2	5/2009	Li et al.	2009/0088756 A1	4/2009	Anderson
7,542,791 B2	6/2009	Mire et al.	2009/0099404 A1	4/2009	Kraus et al.
7,549,960 B2	6/2009	Govari	2009/0165573 A1	7/2009	Ledoux et al.
7,575,550 B1	8/2009	Govari	2009/0177080 A1	7/2009	Kristan et al.
7,686,818 B2	3/2010	Simon et al.	2009/0227862 A1	9/2009	Smith et al.
7,702,379 B2	4/2010	Avinash et al.	2009/0306665 A1	12/2009	Lerner et al.
7,727,240 B1	6/2010	Benton	2009/0326537 A1	12/2009	Anderson
7,729,742 B2	6/2010	Govari	2010/0041985 A1	2/2010	Simon et al.
7,785,330 B2	8/2010	Sherman et al.	2010/0145337 A1	6/2010	Janna et al.
7,835,785 B2	11/2010	Scully et al.	2010/0152566 A1	6/2010	Rains et al.
7,840,254 B2	11/2010	Glossop	2010/0152573 A1	6/2010	Ritchey et al.
7,925,068 B2	4/2011	Hoctor et al.	2010/0211177 A1	8/2010	Abdou
8,066,706 B2	11/2011	Schlienger et al.	2010/0274121 A1	10/2010	Ritchey et al.
8,197,494 B2	6/2012	Jaggi et al.	2010/0274256 A1	10/2010	Ritchey et al.
8,301,262 B2	10/2012	Mi et al.	2010/0274306 A1	10/2010	Pastore et al.
2002/0032445 A1	3/2002	Fujiwara	2010/0289491 A1	11/2010	Budker et al.
2002/0052604 A1	5/2002	Simon et al.	2011/0082366 A1	4/2011	Scully et al.
2002/0173792 A1	11/2002	Severns et al.	2011/0109311 A1	5/2011	Walsh
2003/0105470 A1	6/2003	White	2011/0208037 A1	8/2011	Rains et al.
2003/0120150 A1	6/2003	Govari	2011/0270080 A1	11/2011	Crane
2003/0135211 A1	7/2003	Cho	2011/0295108 A1	12/2011	Cox et al.
2003/0164172 A1	9/2003	Chumas et al.	2012/0010500 A1	1/2012	Couture et al.
2003/0187351 A1*	10/2003	Franck et al. 600/429	2012/0035468 A1	2/2012	Ritchey et al.
2003/0208122 A1	11/2003	Melkent et al.	2012/0091122 A1	4/2012	Ahmad et al.
2004/0011365 A1	1/2004	Govari et al.	2012/0143047 A1	6/2012	Kimura et al.
2004/0034355 A1	2/2004	Govari et al.	2012/0184844 A1	7/2012	Gielen et al.
2004/0243148 A1	12/2004	Wasielewski	2012/0220107 A1	8/2012	Fukuda et al.
			2012/0227542 A1	9/2012	Koch

(56)

References Cited

U.S. PATENT DOCUMENTS

FOREIGN PATENT DOCUMENTS

DE	102008023760	12/2009
EP	523905	5/1993
EP	628287	4/1995
EP	1391181	2/2004
EP	1570782	9/2005
EP	1382308	11/2005
EP	1803394	7/2007
EP	1570781	9/2009
EP	2130511	12/2009
EP	1743590	10/2010
GR	1005791	1/2008
WO	WO9500085	1/1995
WO	WO9713467	4/1997
WO	WO9832387 A1	7/1998
WO	WO9947052	9/1999
WO	WO0134016	10/2001
WO	WO03044556	5/2003
WO	WO03105659	12/2003
WO	WO2004069063	8/2004
WO	WO2005120203	12/2005
WO	WO2007009088	1/2007
WO	WO2007025191	3/2007
WO	WO2007061890	5/2007
WO	WO2007133168	11/2007
WO	WO2008105874	9/2008
WO	WO2008106593	9/2008
WO	WO2009108214	9/2009
WO	WO2009131999	10/2009
WO	WO2010028046	3/2010
WO	WO2010099247	9/2010
WO	WO2010129141	11/2010
WO	WO2010129308 A2	11/2010

OTHER PUBLICATIONS

Ekliptik, Lidis module, brochure, 2010.
 Brochure for GE Healthcare Drapes and Sterile Covers, accessed on Jun. 21, 2012, at <http://www.gehealthcare.com/usen/xr/surgery/docs/SurgeryDrapes&Film.pdf>.
 Ekliptik, "User Manual: Guiding Star/Lidis," Jun. 16, 2010, reprinted from http://www.ekliptik.si/html/downloads/documents/manuals/LIDIS_user_manual.pdf.
 Medtronic, "Orthopaedic Navigation Solutions," 2005, reprinted from http://behzadisportsdoc.com/wordpress/wp-content/uploads/2011/05/medtronic_orthonavsolutions.pdf.

GE Healthcare, "Interventional X-ray, OEC C-arm," 2012.
 Ekliptik, Guiding Star, Lidis: The Best Solution for Distal Interlocking, 2008, 2 pages.
 International Search Report for International Application No. PCT/US2008/055300, mailed Sep. 17, 2008, 3 pages.
 International Preliminary Report on Patentability and Written Opinion for International Application No. PCT/US2008/055300, mailed Sep. 1, 2009, 6 pages.
 International Preliminary Report on Patentability and Written Opinion for International Application No. PCT/US2007/063001, mailed Sep. 1, 2009, 5 pages.
 International Search Report for International Application No. PCT/US2007/063001, mailed Nov. 30, 2007, 3 pages.
 Rains, et al., U.S. Appl. No. 12/919,255, filed Aug. 25, 2010.
 International Search Report for International Application No. PCT/US2008/074520, mailed Jan. 23, 2009, 2 pages.
 Ekliptik, "Guiding Star", reprinted from <http://ekliptik.si/content/view/37/42>, on Jul. 1, 2010, 2 pages.
 Ritchey, et al., U.S. Appl. No. 29/376,026, filed Sep. 30, 2010.
 International Search Report and Written Opinion for International Application No. PCT/US2010/032634, mailed Jan. 26, 2011, 10 pages.
 International Search Report and Written Opinion for PCT/US2010/030784, mailed Oct. 29, 2010, 11 pages.
 European Search Report for European Application No. 07830964.7, mailed Jun. 18, 2010, 4 pages.
 Office Action for Chinese Application No. 200880006490.9, mailed Mar. 31, 2011, 13 pages.
 International Search Report and Written Opinion for International Application No. PCT/US2010/051678, mailed Apr. 14, 2011, 8 pages.
 Office Action for European Application 08872996.7-1269, Jul. 21, 2011, 5 pages.
 "Innomed Hip Instruments-hohmann retractors," reprinted from http://www.innomed.net/hip_rets_hohmanns.htm on Jan. 6, 2011, 8 pages.
 Office Action for U.S. Appl. No. 12/547,716, mailed Apr. 2, 2012, 11 pages.
 Office Action for U.S. Appl. No. 12/528,253, mailed Mar. 21, 2012, 9 pages.
 Office Action for U.S. Appl. No. 12/758,747, mailed Apr. 10, 2012, 11 pages.
Ex Parte Quayle Action in U.S. Appl. No. 29/376,026, mailed Apr. 30, 2012, 10 pages.
 Office Action for U.S. Appl. No. 12/919,255, mailed May 25, 2012.

* cited by examiner

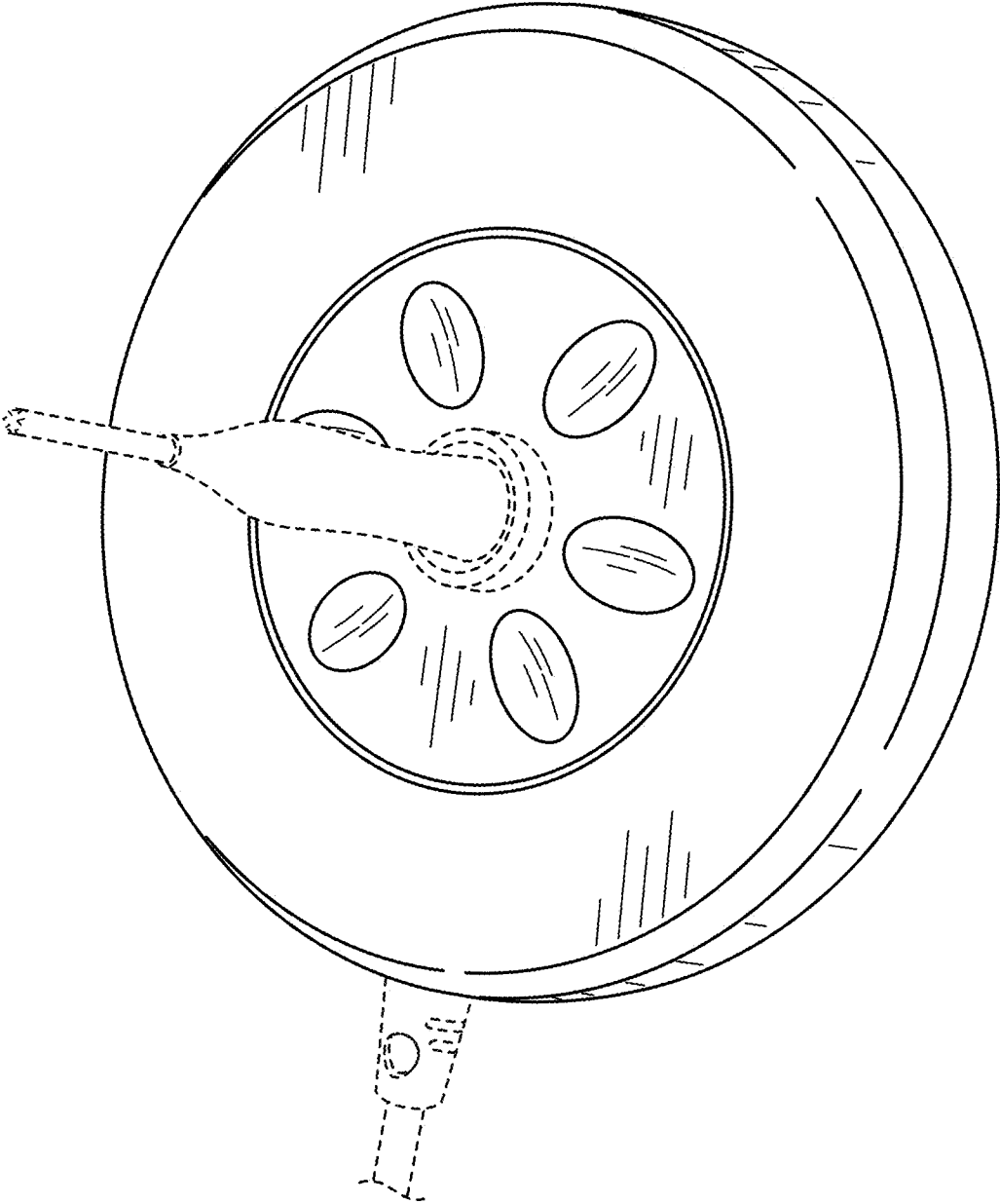

FIG. 1

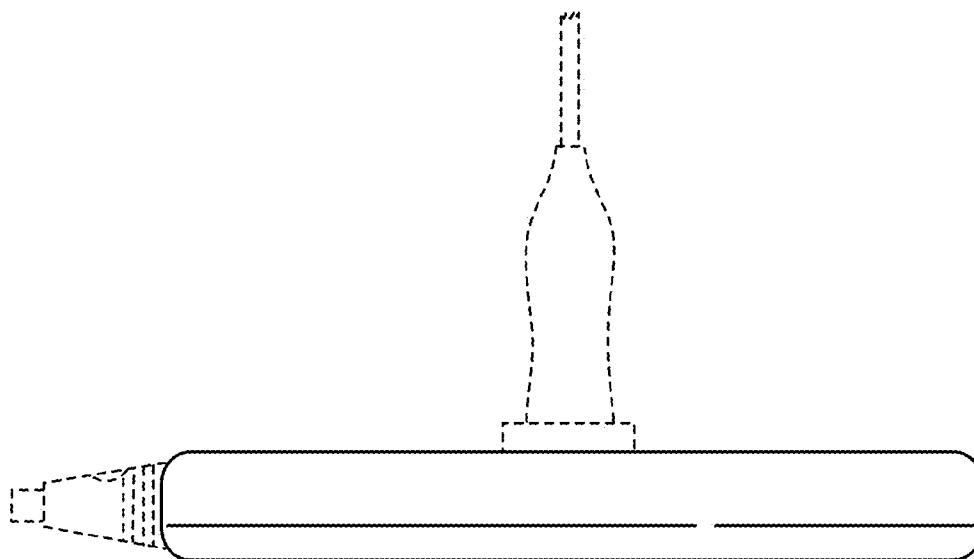

FIG. 2

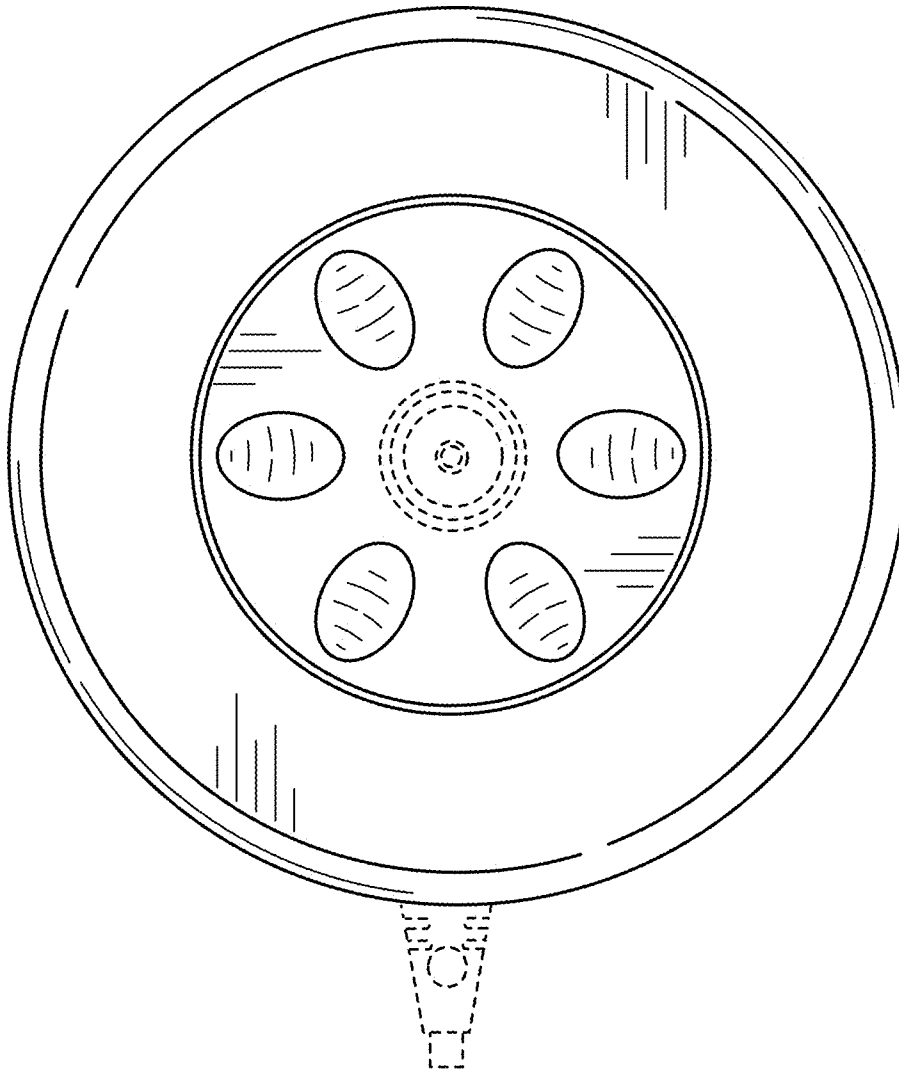

FIG. 3

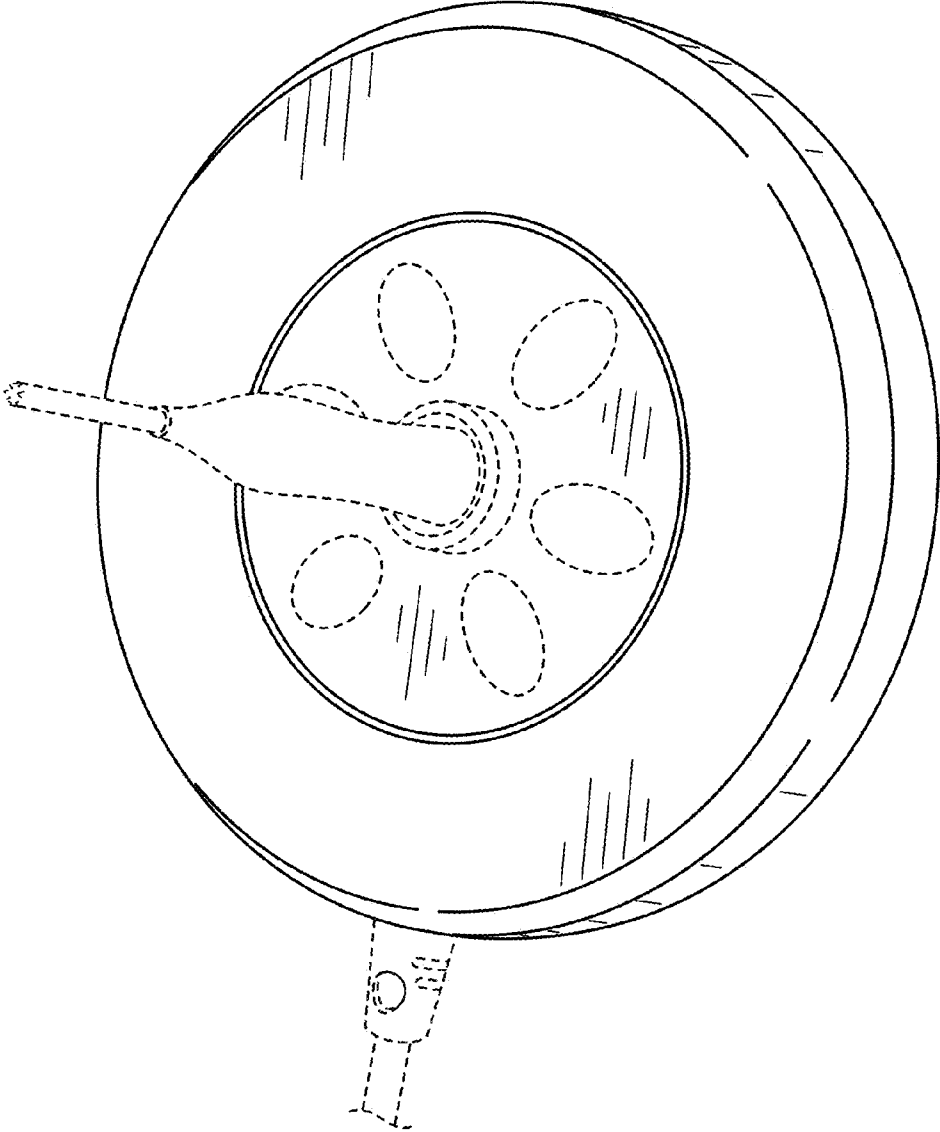

FIG. 4

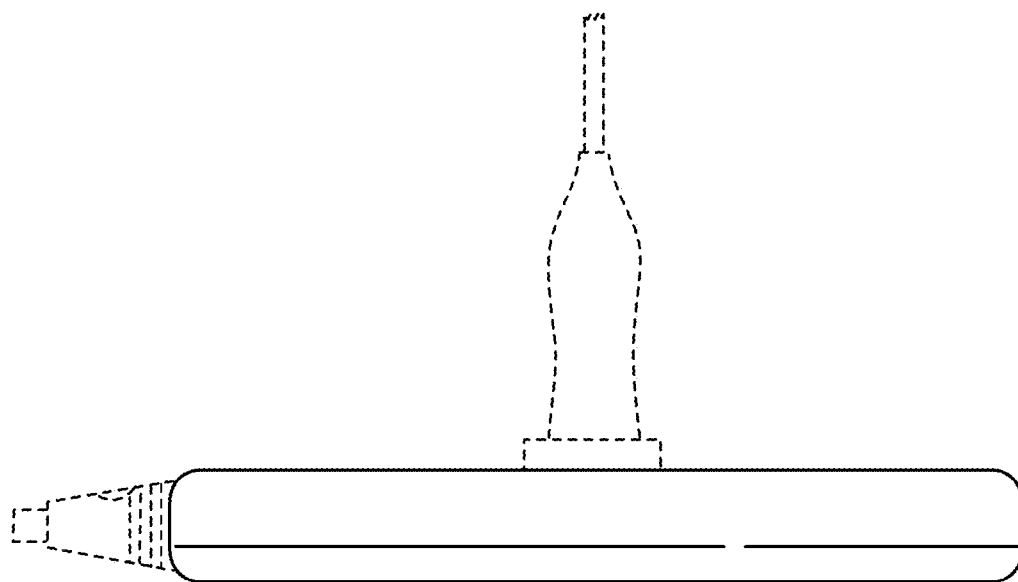

FIG. 5

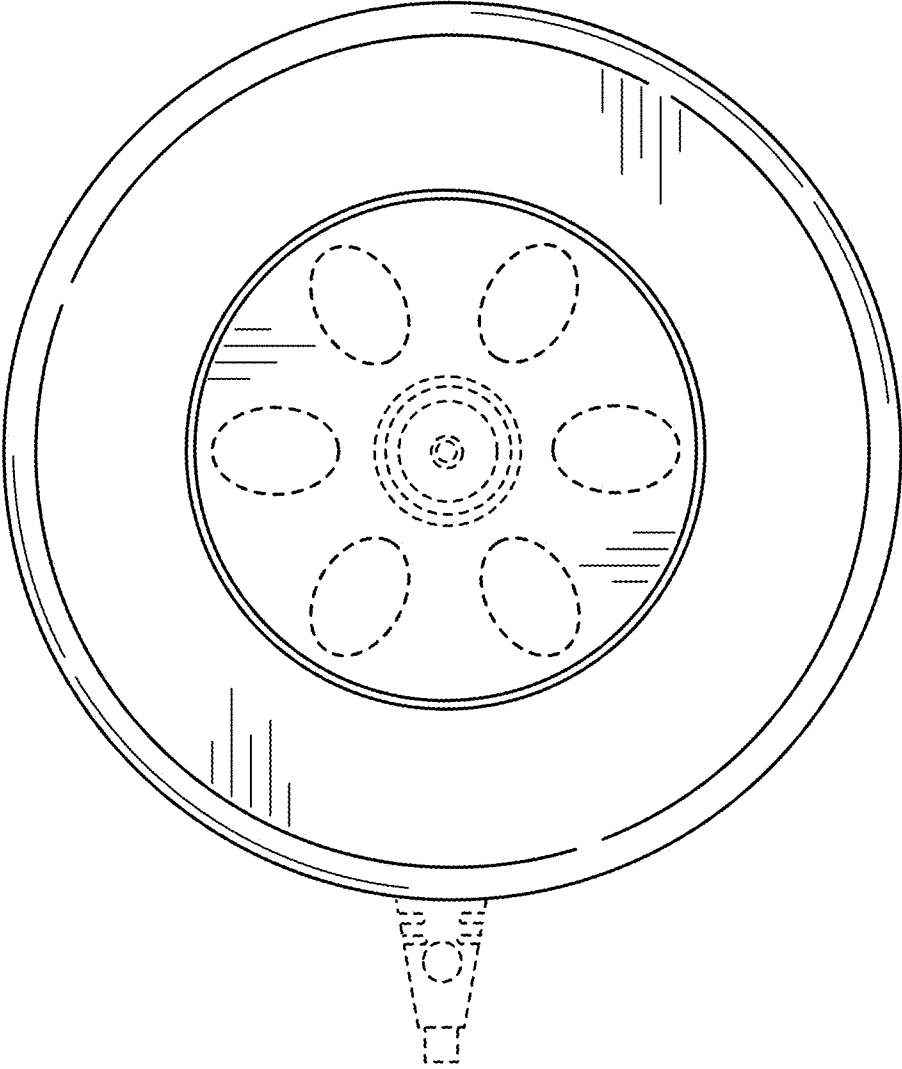

FIG. 6