



(86) Date de dépôt PCT/PCT Filing Date: 2011/10/10
 (87) Date publication PCT/PCT Publication Date: 2012/04/19
 (85) Entrée phase nationale/National Entry: 2013/04/11
 (86) N° demande PCT/PCT Application No.: US 2011/055598
 (87) N° publication PCT/PCT Publication No.: 2012/051108
 (30) Priorités/Priorities: 2010/10/11 (US12/902,085);
 2010/10/19 (US61/394,592); 2011/05/11 (US61/485,009)

(51) Cl.Int./Int.Cl. *A61F 5/00* (2006.01)
 (71) Demandeur/Applicant:
 ALLERGAN INC., US
 (72) Inventeurs/Inventors:
 BABKES, MITCHELL H., US;
 DOMINGUEZ, ZACHARY P., US;
 MUDD, CHRISTOPHER S., US;
 RAVEN, JOSEPH S., US
 (74) Agent: GOWLING LAFLEUR HENDERSON LLP

(54) Titre : REFORMAGE D'IMPLANTS INTRAGASTRIQUES
 (54) Title: RE-SHAPING INTRAGASTRIC IMPLANTS

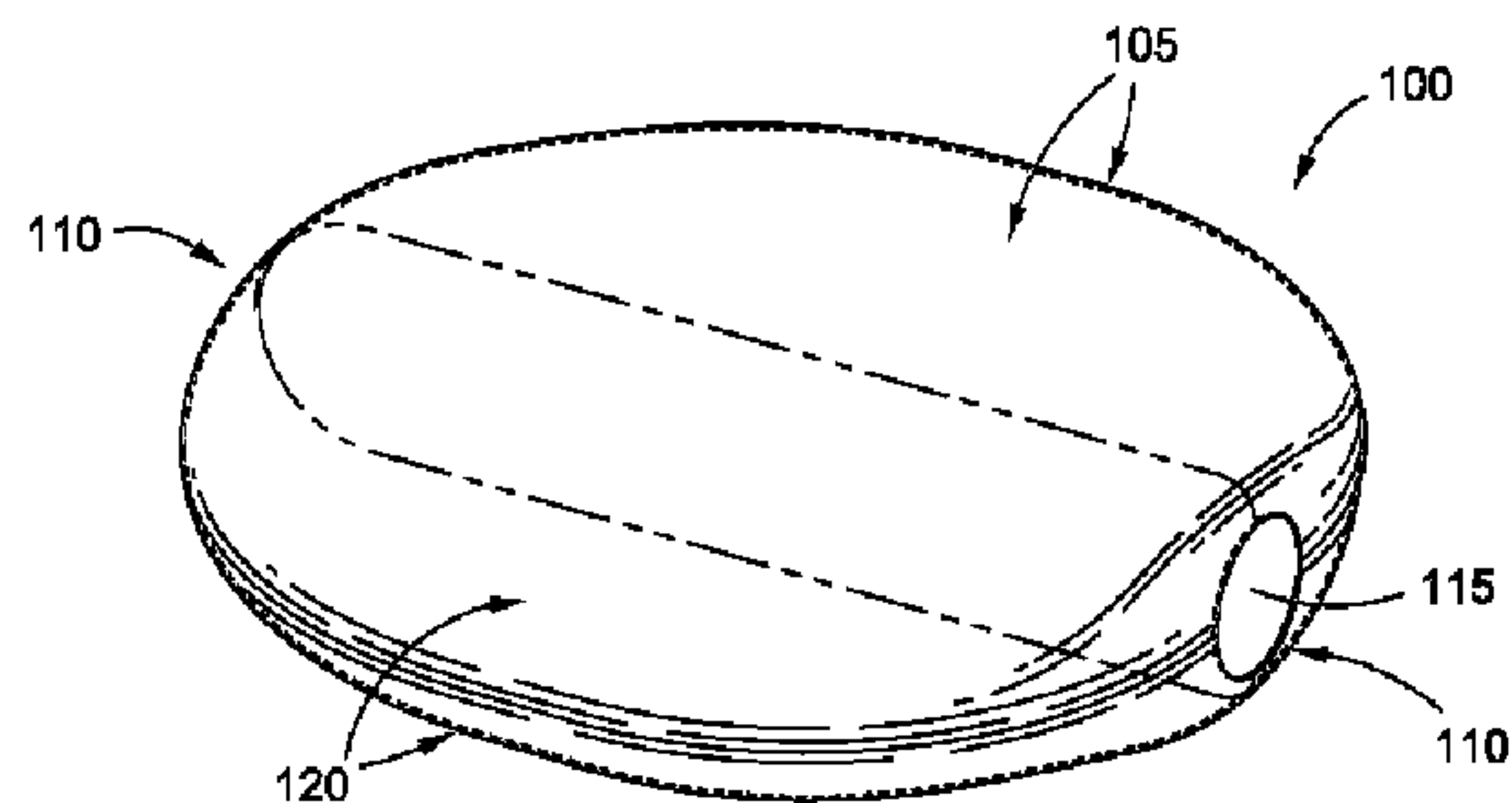

FIG. 1A

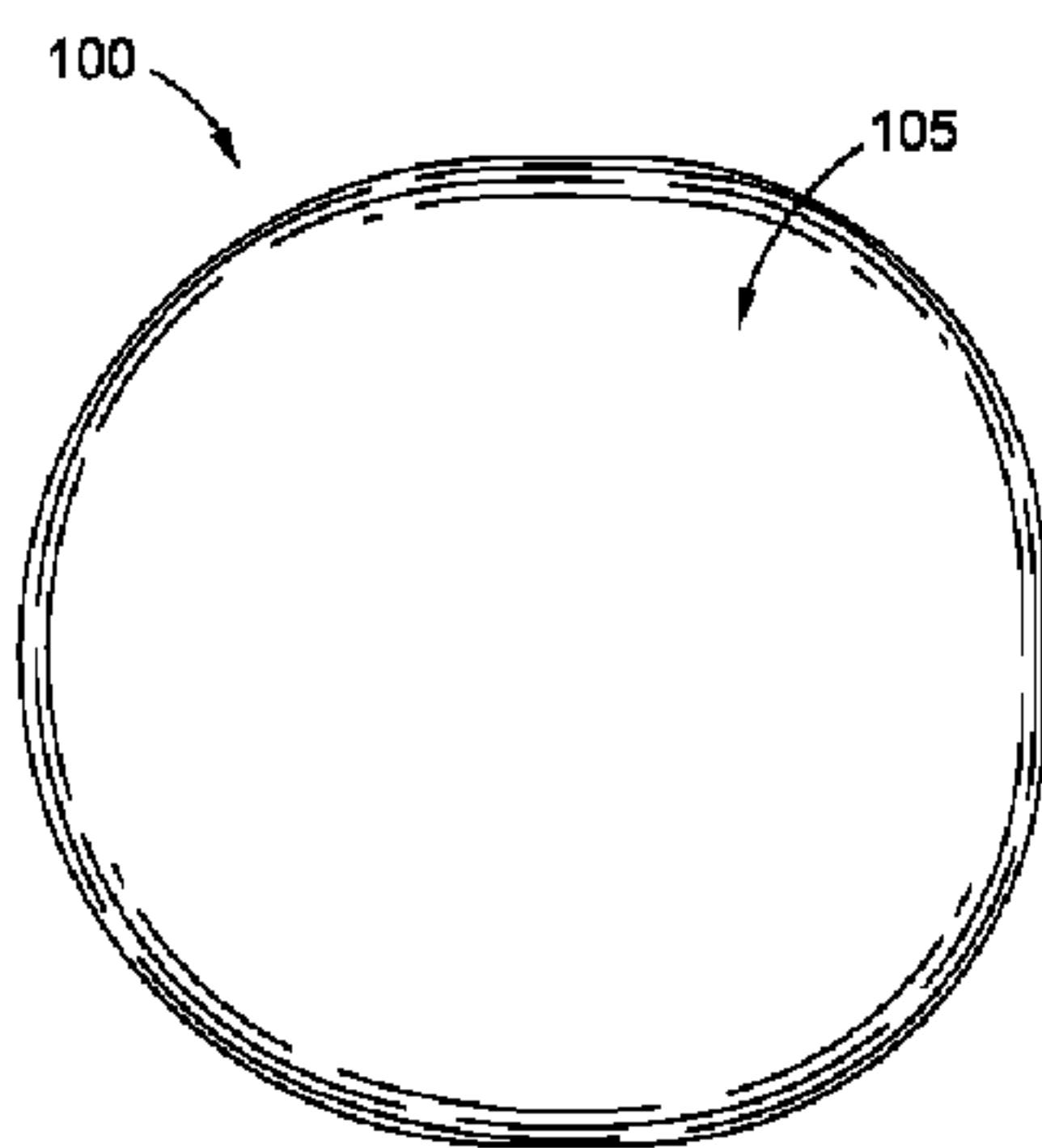

FIG. 1B

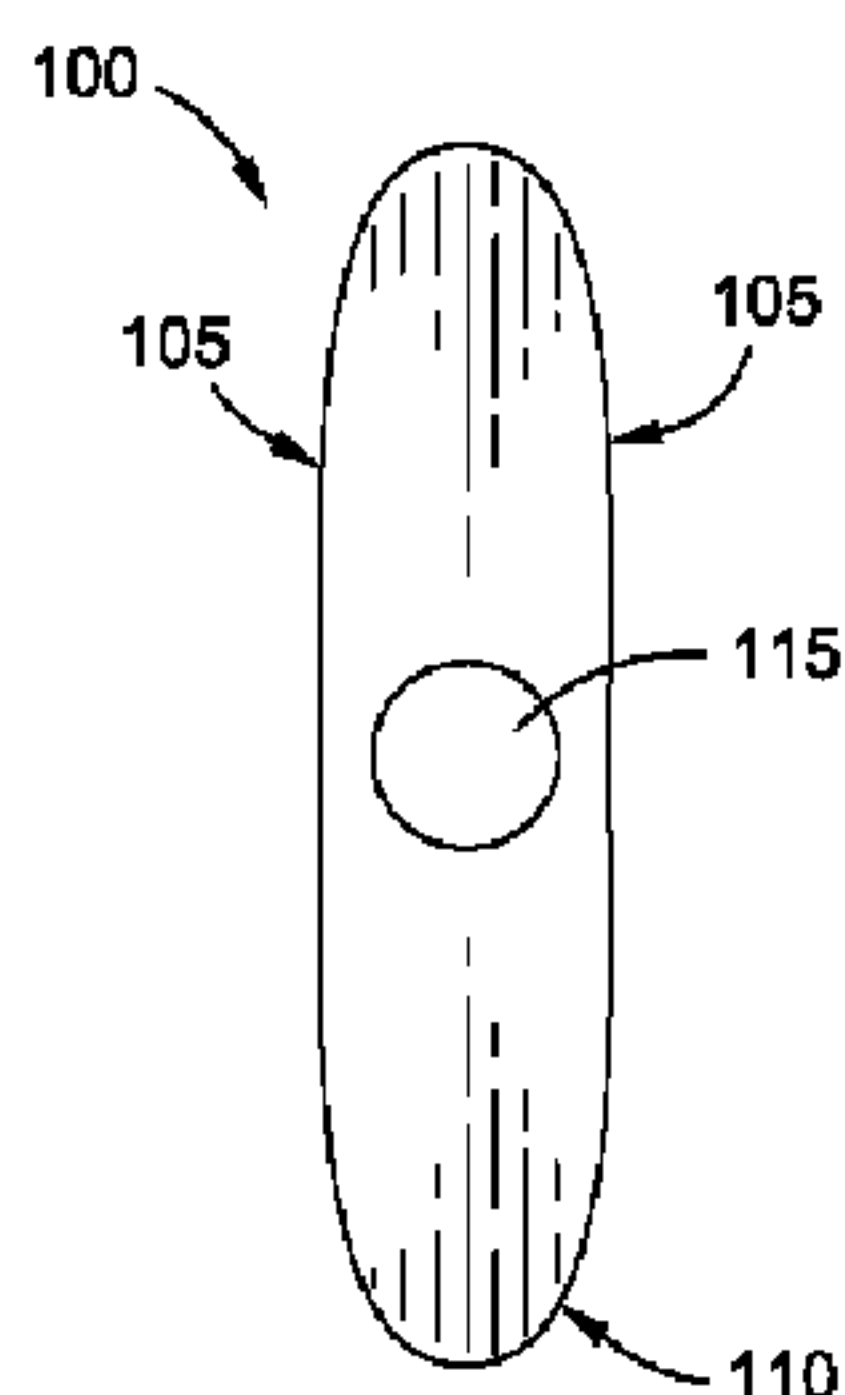

FIG. 1D

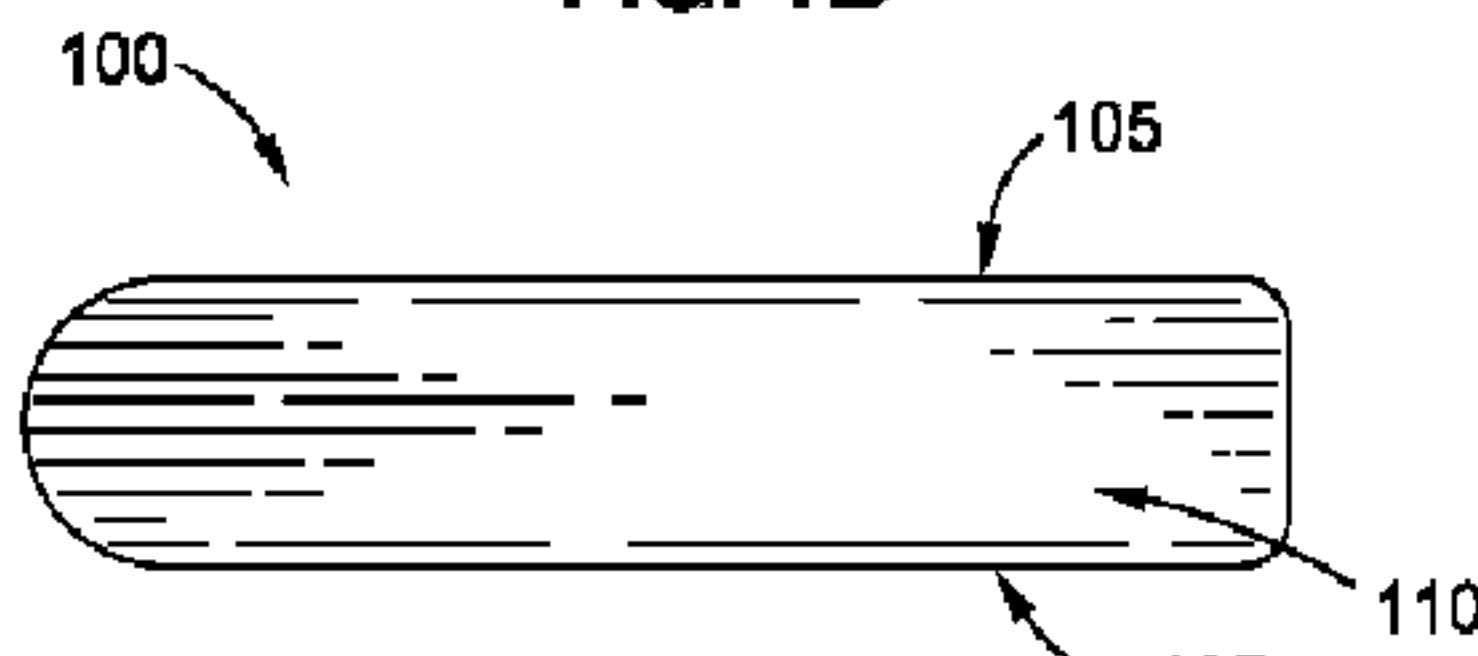

FIG. 1C

(57) **Abrégé/Abstract:**

The present application provides implantable intragastric devices for the treatment of obesity. The intragastric devices advantageously act as a volume-occupying device, and is able to survive implantation in a patient's stomach for a year or longer. In

(57) **Abrégé(suite)/Abstract(continued):**

addition, the intragastric devices may be configured to stimulate an inner stomach wall and/or temporarily block the pylorus to slow gastric emptying and/or be rotationally variant, thereby encouraging different stimulation points on the inner wall of the stomach and limiting the stomach's ability to adapt over long term implantation. The intragastric devices may reshape the stomach cavity, such as by pushing on opposite sides so as to "planarize" the stomach. For instance, the device may be an inflated disk, or an implantable loop or a springy coil that may be straightened for delivery/extraction yet assume the loop or coil shape upon implant.

(12) INTERNATIONAL APPLICATION PUBLISHED UNDER THE PATENT COOPERATION TREATY (PCT)

(19) World Intellectual Property
Organization
International Bureau(43) International Publication Date
19 April 2012 (19.04.2012)(10) International Publication Number
WO 2012/051108 A4(51) International Patent Classification:
A61F 5/00 (2006.01)

(21) International Application Number:

PCT/US2011/055598

(22) International Filing Date:

10 October 2011 (10.10.2011)

(25) Filing Language:

English

(26) Publication Language:

English

(30) Priority Data:

12/902,085	11 October 2010 (11.10.2010)	US
61/394,592	19 October 2010 (19.10.2010)	US
61/485,009	11 May 2011 (11.05.2011)	US

(71) Applicant (for all designated States except US): **ALLERGAN, INC.** [US/US]; 2525 Dupont Drive, Irvine, California 92612 (US).

(72) Inventors; and

(75) Inventors/Applicants (for US only): **BABKES, Mitchell H.** [US/US]; 21424 Angela Yvonne Ave, Santa Clarita,California 91350 (US). **DOMINGUEZ, Zachary P.** [US/US]; 210 Bath Street, Santa Barbara, California 93101 (US). **MUDD, Christopher S.** [US/US]; 5477 Ralston Street #201, Ventura, California 93117 (US). **RAVEN, Joseph S.** [US/US]; 1540 Holiday Hill Road, Goleta, California 93117 (US).(74) Agents: **DONOVAN, Stephen** et al.; Allergan, Inc., 2525 Dupont Drive, Irvine, California 92612 (US).

(81) Designated States (unless otherwise indicated, for every kind of national protection available): AE, AG, AL, AM, AO, AT, AU, AZ, BA, BB, BG, BH, BR, BW, BY, BZ, CA, CH, CL, CN, CO, CR, CU, CZ, DE, DK, DM, DO, DZ, EC, EE, EG, ES, FI, GB, GD, GE, GH, GM, GT, HN, HR, HU, ID, IL, IN, IS, JP, KE, KG, KM, KN, KP, KR, KZ, LA, LC, LK, LR, LS, LT, LU, LY, MA, MD, ME, MG, MK, MN, MW, MX, MY, MZ, NA, NG, NI, NO, NZ, OM, PE, PG, PH, PL, PT, QA, RO, RS, RU, RW, SC, SD, SE, SG, SK, SL, SM, ST, SV, SY, TH, TJ, TM, TN, TR, TT, TZ, UA, UG, US, UZ, VC, VN, ZA, ZM, ZW.

[Continued on next page]

(54) Title: RE-SHAPING INTRAGASTRIC IMPLANTS

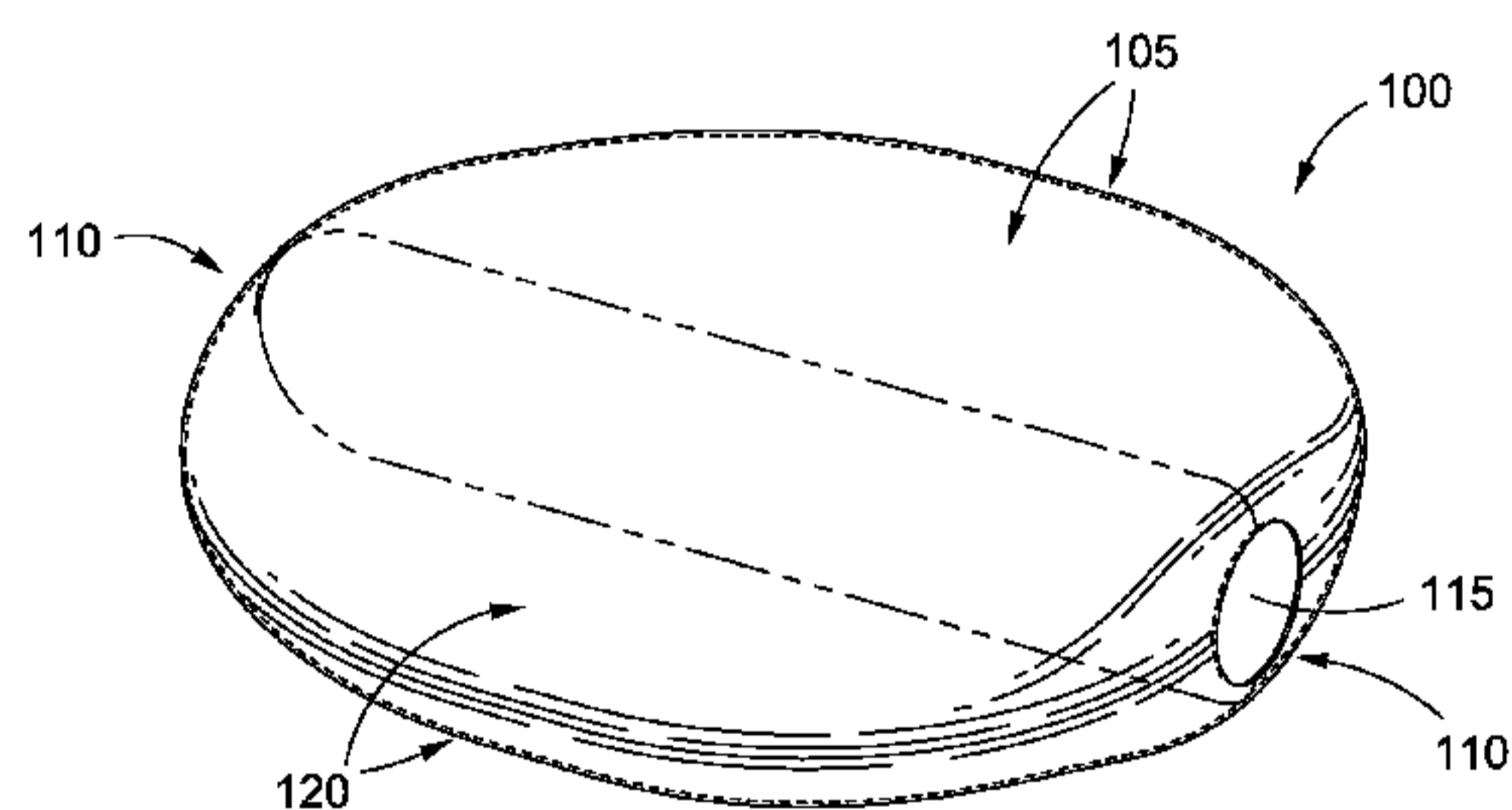

FIG. 1A

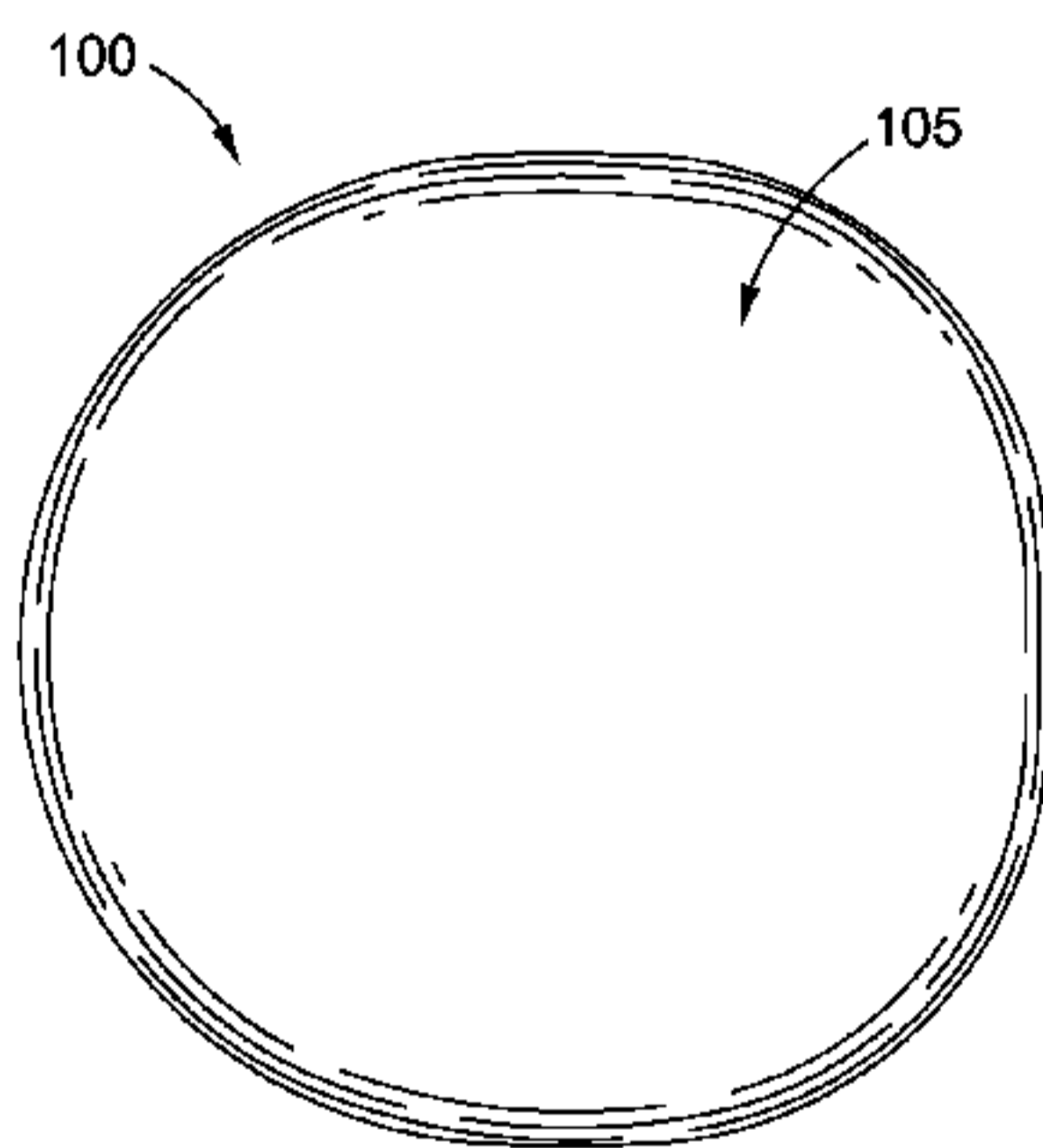

FIG. 1B

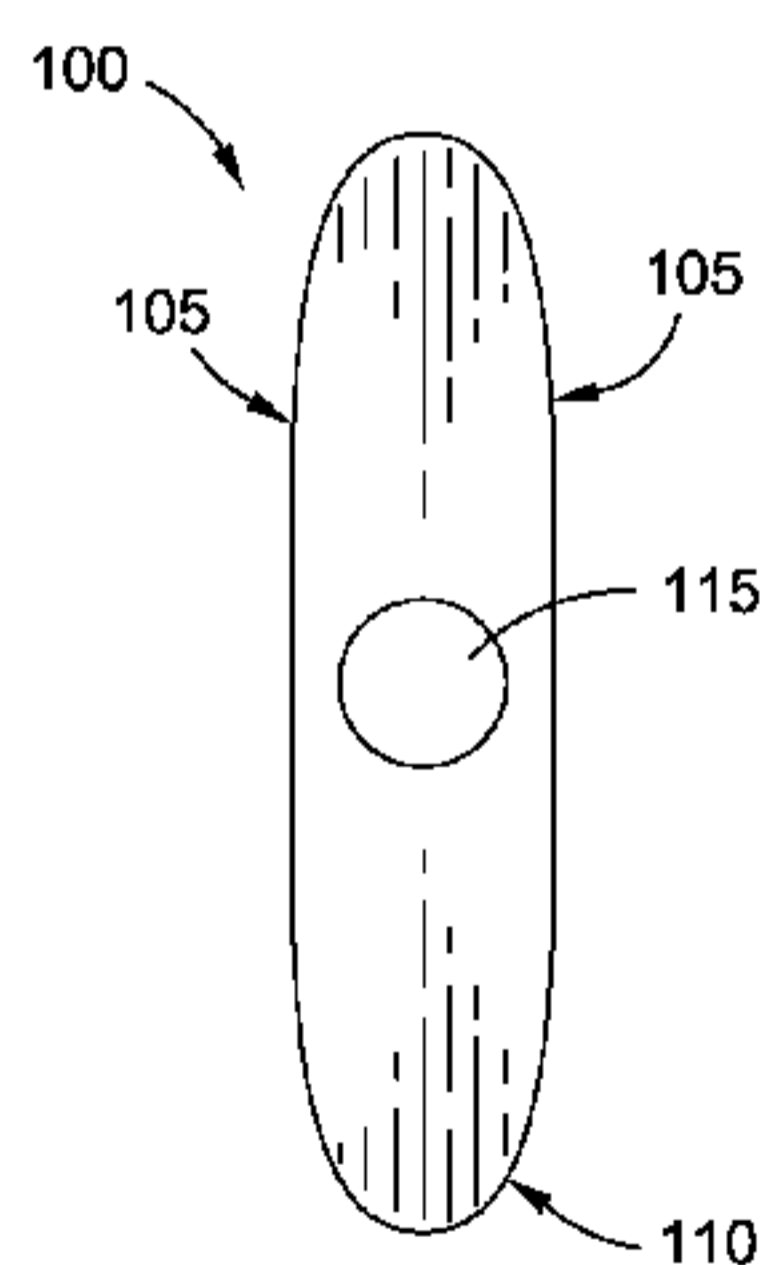

FIG. 1D

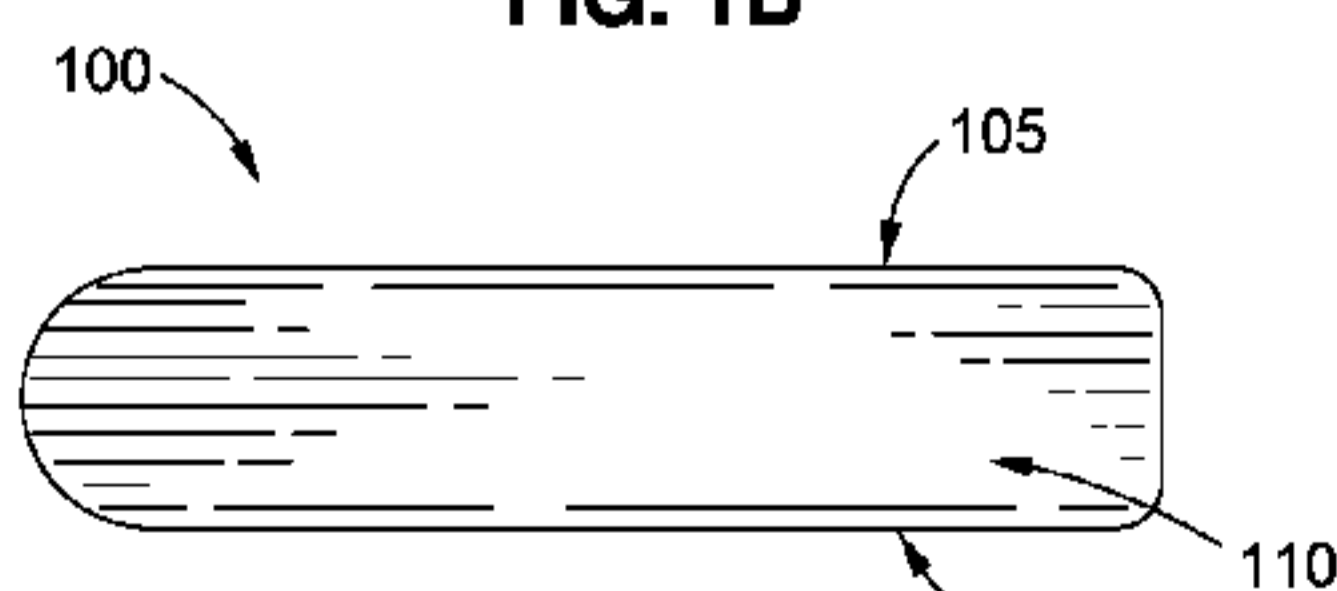

FIG. 1C

(57) Abstract: The present application provides implantable intragastric devices for the treatment of obesity. The intragastric devices advantageously act as a volume-occupying device, and is able to survive implantation in a patient's stomach for a year or longer. In addition, the intragastric devices may be configured to stimulate an inner stomach wall and/or temporarily block the pylorus to slow gastric emptying and/or be rotationally variant, thereby encouraging different stimulation points on the inner wall of the stomach and limiting the stomach's ability to adapt over long term implantation. The intragastric devices may reshape the stomach cavity, such as by pushing on opposite sides so as to "planarize" the stomach. For instance, the device may be an inflated disk, or an implantable loop or a springy coil that may be straightened for delivery/extraction yet assume the loop or coil shape upon implant.

WO 2012/051108 A4



- (84) Designated States** (*unless otherwise indicated, for every kind of regional protection available*): ARIPO (BW, GH, GM, KE, LR, LS, MW, MZ, NA, RW, SD, SL, SZ, TZ, UG, ZM, ZW), Eurasian (AM, AZ, BY, KG, KZ, MD, RU, TJ, TM), European (AL, AT, BE, BG, CH, CY, CZ, DE, DK, EE, ES, FI, FR, GB, GR, HR, HU, IE, IS, IT, LT, LU, LV, MC, MK, MT, NL, NO, PL, PT, RO, RS, SE, SI, SK, SM, TR), OAPI (BF, BJ, CF, CG, CI, CM, GA, GN, GQ, GW, ML, MR, NE, SN, TD, TG).
- *as to the applicant's entitlement to claim the priority of the earlier application (Rule 4.17(iii))*
- Published:**
- *with international search report (Art. 21(3))*
- *with amended claims (Art. 19(1))*
- (88) Date of publication of the international search report:**
5 July 2012
- Date of publication of the amended claims:** 23 August 2012
- Declarations under Rule 4.17:**
- *as to applicant's entitlement to apply for and be granted a patent (Rule 4.17(ii))*

RE-SHAPING INTRAGASTRIC IMPLANTS

By

MITCHELL H. BABKES, ZACHARY P. DOMINGUEZ, CHRISTOPHER S. MUDD,
AND JOSEPH S. RAVEN

RELATED APPLICATIONS

[0001] The present application is a continuation-in-part of U.S. Application Serial No. 12/902,085, filed October 11, 2010, and also claims priority under 35 U.S.C. §119 to U.S. Provisional Application No. 61/485,009, filed May 11, 2011, and to 61/394,592, filed October 19, 2010, the disclosures of which is incorporated by reference herein.

FIELD OF THE INVENTION

[0002] The present application relates, in general, to devices and methods for controlling obesity, and, more particularly, to an intragastric device designed to promote satiety by occupying volume in a patient's stomach.

BACKGROUND OF THE INVENTION

[0003] Over the last 50 years, obesity has been increasing at an alarming rate and is now recognized by leading government health authorities, such as the Centers for Disease Control (CDC) and National Institutes of Health (NIH), as a disease. In the United States alone, obesity affects more than 60 million individuals and is considered the second leading cause of preventable death. Worldwide, approximately 1.6 billion adults are overweight, and it is estimated that obesity affects at least 400 million adults.

[0004] Obesity is caused by a wide range of factors including genetics, metabolic disorders, physical and psychological issues, lifestyle, and poor nutrition. Millions of obese and overweight individuals first turn to diet, fitness and medication to lose weight; however, these efforts alone are often not enough to keep weight at a level that is optimal for good health. Surgery is another increasingly viable alternative for those with a Body Mass Index (BMI) of greater than 40. In fact, the number of bariatric surgeries in the United States is projected to reach approximately 400,000 annually by 2010.

[0005] Examples of surgical methods and devices used to treat obesity include the The LAP-BAND® (Allergan, Inc., Irvine, CA) gastric band and the LAP-BAND AP® (Allergan, Inc., Irvine, CA) gastric band. However, surgery might not be an option for every obese individual; for certain patients, non-surgical therapies or minimal-surgery options are more effective or appropriate.

[0006] In the early 1980s, physicians began to experiment with the placement of intragastric balloons to reduce the size of the stomach reservoir, and consequently its capacity for food. Once deployed in the stomach, the balloon helps to trigger a sensation of fullness and a decreased feeling of hunger. These devices are designed to provide therapy for moderately obese individuals who need to shed pounds in preparation for surgery, or as part of a dietary or behavioral modification program. These balloons are typically cylindrical or pear-shaped, generally range in size from 200-500 ml or more, are made of an elastomer such as silicone, polyurethane, or latex, and are filled with air, an inert gas, water, or saline.

[0007] One such inflatable intragastric balloon is described in U.S. Pat. No. 5,084,061 and is commercially available as the BioEnterics Intragastric Balloon System ("BIB System", sold under the trademark ORBERA). The BIB System comprises a silicone elastomer intragastric balloon that is inserted into the stomach and filled with fluid. Conventionally, the balloons are placed in the stomach in an empty or deflated state and thereafter filled (fully or partially) with a suitable fluid. The balloon occupies space in the stomach, thereby leaving less room available for food and creating a feeling of satiety for the patient. Clinical results with these devices show that for many obese patients, the intragastric balloons significantly help to control appetite and accomplish weight loss.

[0008] Placement of such balloons is temporary, and such balloons are typically removed after about six months. One means of removing the balloon is to deflate it by puncturing the balloon, and either aspirating the contents of the balloon or allowing the fluid to pass into the patient's stomach. Alternatively, if the balloon is left in place beyond its designed lifetime, the acids present in a patient's stomach may erode the balloon to the point where it self-deflates. When this occurs, the deflated balloon may pass naturally through the patient's digestive system and be expelled through the bowel. For instance, McGhan, U.S. Pat. No. 6,733,512, describes a self-deflating intragastric balloon that includes a biodegradable inflation valve. After a certain residence time in the stomach, the valve starts to leak and eventually the balloon deflates and passes through the patient's digestive tract.

[0009] Despite the advances in the design of intragastric balloons, there remains a need for improved medical systems, apparatus and uses thereof for treating obesity and/or obesity-related diseases, and more specifically, to devices designed to stimulate the internal surfaces of the stomach to induce a feeling of satiety.

SUMMARY OF THE INVENTION

[0010] The medical systems, apparatus and uses thereof for treating obesity and/or obesity-related diseases described herein relate to intragastric implant devices designed to stimulate internal surfaces of the stomach. This pressure or stimulation generally promotes a feeling of satiety reducing the amount of food consumed or digested by the patient. The medical systems, apparatus and uses thereof for treating obesity and/or obesity-related diseases described herein may also relate to reducing the space in the stomach, thus advantageously reducing the amount of food consumed or digested by the patient. The intragastric devices described herein may be implanted transorally, through the esophagus and into the patient's stomach without surgery or using only a minimally invasive surgical procedure. At the conclusion of treatment, the intragastric device may be retrieved gastroendoscopically. The intragastric device improves the overall efficacy of transoral obesity reducing devices by achieving a substantial reduction in device weight and may include an identical or improved space-occupying volume when compared to existing devices (e.g., the Orbera® System).

[0011] In a first embodiment, an intragastric obesity treatment implant that stimulates the stomach walls comprises an inflatable member having an inflated size that will not pass through the pyloric sphincter and a volume within the stomach of at least 400 ml. The implant is made of a material that will resist degradation over a period of at least six months within the stomach and is formed as a substantially planar disc having opposed faces and a peripheral surface and a maximum width larger than the contracted width of an adult stomach so alter the shape of the stomach to conform somewhat to the inflatable member. The implant is formed of a material which permits it to be compressed when deflated into a substantially linear delivery configuration.

[0012] The implant may further include a plurality of dimples on each opposed face of the substantially planar disc defining points at which the opposed faces are connected through an inner cavity to help retain the substantially planar disc shape. In one embodiment, the opposed faces and peripheral surface are smooth, wherein in another version at least some of the opposed

faces and peripheral surface are irregular in a pattern selected from the group consisting of a rounded protrusion, a quill-like extension, a recess, and combinations thereof. The opposed faces may be generally circular with a diameter, and the peripheral surface defines a thickness that is less than one-half the diameter. In one embodiment, the implant is constructed out of a material selected from a group consisting of a rubber, a fluorosilicone, a fluoroelastomer, a thermoplastic elastomer, and combinations thereof.

[0013] Another intragastric obesity treatment implant that stimulates the stomach walls disclosed herein includes an elongated member having a relaxed configuration that forms a coil. Opposite free ends of the coil overlap one another to permit constriction of the coil. The coil has a diameter that generally fits within the stomach of an adult patient so as to contact the interior stomach walls upon contraction thereof, and the elongated member is formed of a material which permits it to be stretched into a substantially linear delivery configuration and that will resist degradation over a period of at least six months within the stomach. The coil in its relaxed configuration preferably has a diameter of between about 15-16 cm. The coil may comprise an inner pre-formed wire such as Nitinol placed inside a soft and fairly flexible plastic tubular sheath. The two free ends of the wire are desirably captured by two end caps that close open ends of the sheath, and the assembled components of the wire, sheath and end caps are preferably coated with a flexible compound that is resistant to stomach juices. Alternatively, the wire is embedded within the sheath with no hollow spaces therebetween.

[0014] In a still further intragastric obesity treatment implant disclosed herein, an elongated hollow member has a relaxed configuration that forms a loop, opposite free ends of the loop being adapted to connect together, and the loop having a diameter that generally fits within the stomach of an adult patient so as to contact the interior stomach walls upon contraction thereof. The elongated hollow member is formed of a material which permits it to be stretched into a substantially linear delivery configuration and that will resist degradation over a period of at least six months within the stomach. The elongated hollow member further may include perforations along its length to permit ingress of stomach fluids.

[0015] In one embodiment, the elongated hollow member has a distal end connector with a lumen, and a proximal end connector with a lumen and a side aperture spaced from the proximal end connector, the implant further including a tether that extends through the hollow lumen on the distal end connector and is secured therein, and passes in through the proximal end connector lumen and outward through the side aperture, the proximal and distal end connectors being brought together upon pulling the tether taut. The loop may have a diameter of between about

15-16 cm, and further may include a spring placed inside the elongated hollow member to provide resiliency and prevent kinking of the elongated hollow member. The loop may also be constructed by cutting a plastic tube in two to form two smaller diameter half tubes that fit inside a larger diameter whole tube.

[0016] In one embodiment, an intragastric device may have a flat profile and configured to planarize the stomach by forming a wall-like divider in the stomach.

[0017] In another embodiment, an intragastric device may have a plurality of round protrusions or “bumps.”

[0018] In another embodiment, an intragastric device may have a plurality of legs, each of the plurality of legs having an enlarged end portion.

[0019] In another embodiment, an intragastric device may be substantially spherical and may include a plurality of protrusions spaced out on an outer surface of the intragastric device.

[0020] In another embodiment, an intragastric device may be substantially spherical and may include a plurality of spine-like or quill-like protrusions spaced out on an outer surface of the intragastric device.

[0021] In another embodiment, an intragastric device may be substantially spherical and may include a plurality of dimple-like recesses spaced out on an outer surface of the intragastric device.

[0022] For each of the embodiments described above, the intragastric device may be further configured to stimulate an inner stomach wall and/or temporarily block the pylorus to slow gastric emptying and/or be rotationally variant to encourage different stimulation points on the inner wall of the stomach, thereby limiting the ability of the stomach to adapt over long term implantation.

BRIEF DESCRIPTION OF THE DRAWINGS

[0023] Figure 1A is a perspective view of an exemplary intragastric device that is formed with a flattened geometry so as to planarize the stomach.

[0024] Figure 1B is a top view of the intragastric device of Figure 1A.

[0025] Figure 1C is a side view along a first axis of the intragastric device of Figure 1A.

[0026] Figure 1D is a side view along a second axis of the intragastric device of Figure 1A.

[0027] Figure 2 is a perspective view of an alternative intragastric device similar to the flattened device of Figure 1A but having the two flat faces connected for shape retention, and Figure 3 illustrates the flattened device in place within the stomach.

[0028] Figure 4 is a perspective view of a further intragastric obesity treatment device in a straightened configuration for delivery to the stomach, while Figure 4A is a longitudinal sectional view thereof.

[0029] Figure 5 is a perspective view of the device of Figure 4 wherein opposite ends have been attached to form a loop capable of altering the shape of the stomach cavity from the inside, and Figure 5A is a longitudinal sectional view thereof.

[0030] Figure 6 is a perspective view of a further intragastric obesity treatment device in place within the stomach in the shape of a loop capable of altering the shape of the stomach cavity, while Figures 7A and 7B are plan and perspective views thereof.

[0031] Figure 8 is a perspective view of an intragastric device in accordance with one or more embodiments described herein.

[0032] Figure 9 is a perspective view of an intragastric device in accordance with one or more embodiments described herein.

[0033] Figure 10 is a perspective view of an intragastric device in accordance with one or more embodiments described herein.

[0034] Figure 11 is a perspective view of an intragastric device in accordance with one or more embodiments described herein.

[0035] Figure 12A is a perspective view of an intragastric device in accordance with one or more embodiments described herein.

[0036] Figure 12B is a close up view of the intragastric device of Figure 12A in accordance with one or more embodiments described herein.

DETAILED DESCRIPTION

[0037] Persons skilled in the art will readily appreciate that various aspects of the disclosure may be realized by any number of methods and devices configured to perform the intended functions. Stated differently, other methods and devices may be incorporated herein to perform the intended functions. It should also be noted that the drawing figures referred to herein are not all drawn to scale, but may be exaggerated to illustrate various aspects of the invention, and in

that regard, the drawing figures should not be construed as limiting. Finally, although the present disclosure may be described in connection with various medical principles and beliefs, the present disclosure should not be bound by theory.

[0038] By way of example, the present disclosure will reference certain implantable obesity treatment devices. Nevertheless, persons skilled in the art will readily appreciate that various aspects of the present disclosure advantageously may be applied to one of the numerous varieties of implantable obesity treatment devices.

[0039] In one embodiment, these implantable obesity treatment devices described herein are intended to be placed inside the patient, without invasive surgery, without associated patient risks of invasive surgery and without substantial patient discomfort. Recovery time may be minimal as extensive tissue healing is generally not required. The life span of these obesity treatment devices may be material-dependent upon long-term survivability within an acidic stomach, but is intended to last one year or longer in various embodiments. Moreover, each device described herein is designed to stimulate internal surfaces of the stomach. This pressure or stimulation generally promotes a feeling of satiety reducing the amount of food consumed or digested by the patient. The medical systems, apparatus and uses thereof for treating obesity and/or obesity-related diseases described herein may also relate to reducing the space in the stomach, thus advantageously reducing the amount of food consumed or digested by the patient.

[0040] In addition to stimulating the stomach nerves, the devices described herein desirably include geometries that reshape the stomach cavity. Non-uniformity in the cross-sectional shape of the devices can be used to stretch the stomach to a flatter geometry, which in turn reduces the volume capacity of the stomach. For instance, Figures 1-3 show rounded, flattened intragastric devices that retain their shape in the stomach. Figures 4-7 illustrate tubular members that can be formed into loops for planarizing the stomach. Additionally, a number of the devices described herein can be made rotationally variant, such that movement within the stomach results in certain arbitrary rotational adjustments which causes the device to occupy a different 3-dimensional space and orientation. This encourages different stimulation points as the device moves in the stomach, limiting the ability of the stomach to adapt over long term implantation. Still further, outer bumps, protrusions, quill-like extensions, or other surface irregularities may be provided on any of the various shapes to enhance stimulation of the inner wall of the stomach.

[0041] In a first embodiment seen in Figure 1A, an intragastric device **100** has a flat profile configured to planarize the stomach by forming a wall-like divider in the stomach. More particularly, the geometry of the intragastric device **100** stretches the stomach to a flatter

geometry, which causes the volume capacity of the stomach to be substantially reduced. The intragastric device **100** of Figure 1A includes top and bottom surfaces **105**, and a peripheral surface **110** substantially extending around the circumference of intragastric device **100**. The peripheral surface **110** may be oval-shaped and the opposed top and bottom surfaces **105** are generally flat. The long dimension of the oval-shaped peripheral surface **110** will be slightly larger than the longest dimension across any opposite walls of the stomach cavity so that the device changes the shape of the stomach cavity. Desirably, the intragastric device **100** can be either inflated, such as a typical intragastric balloon, or can be molded from a thick-walled polymer so as to be able to retain its shape in the stomach. In the latter configuration, through holes may be provided to allow passage of stomach juices.

[0042] As shown, in Figure 1A, the top and bottom surfaces **105** may comprise a plurality of joined panels **120** attached to each other and also to a circular panel **115** on an end substantially perpendicular to the top and bottom surfaces **105**. As shown, the intragastric device **100** may be constructed of rubber, fluorosilicones, fluoroelastomers, thermoplastic elastomers or any combinations thereof. In one embodiment, the intragastric device **100** is filled with air/inert gas or a liquid such as silicon. The material(s) utilized allow for a thinner wall thickness and have a lower coefficient of friction. Thinner walls and the lower coefficient of friction allows improved natural passage of the intragastric device **100** through the esophagus during delivery, and also through the gastrointestinal tract should the intragastric device **100** deflate for any reason inside the patient's stomach.

[0043] Figure 1B illustrates a top view of the intragastric device **100** of Figure 1A. As illustrated, the intragastric device **100** is substantially circular or slightly oval. However, a different geometry may be implemented. For example, an intragastric device incorporating a more pronounced oval or ellipse-shaped top or bottom surface is possible. Desirably, the end having the circular panel **115** is flat, as shown. The circular panel **115** may provide a self-sealing inflation patch, or may represent a fill valve. While not shown, the top and bottom surfaces **105** may further include stimulation features such as rounded bumps or protrusions, quill-like extensions, dimples or recesses, and the like, as described below. These features, upon contact with the inner stomach wall of the patient may trigger hormone release or otherwise aid the patient in feeling full.

[0044] Figure 1C illustrates a side view of the intragastric device **100** of Figure 1A along one axis of the intragastric device **100**. As shown, the thickness of the intragastric device **100** (or width of the peripheral surface **110**) is even. However, alternative configurations, including

varying thicknesses of the intragastric device **100**, may be possible. In one embodiment, the intragastric device **100** has a diameter of about 5-15 cm (2-6 inches) and a thickness which is one-half or less than the diameter, more preferably less than one-third the diameter. In one example, the thickness is between about 1.2-8 cm (0.5-3 inches), with the lower bound matching the lower bound of the diameter, and vice versa. In a preferred embodiment, the intragastric device **100** has a diameter of about 10-15 cm (4-6 inches) and a thickness of between about 2-4 cm (0.75-1.6 inches), with the lower bound matching the lower bound of the diameter, and vice versa.

[0045] Figure 1D illustrates a side view of the intragastric device **100** of Figure 1A along an axis of the intragastric device **100**. Here, the circular panel **115** is shown in the center of the flat end and does not extend to the end surface **105**. In one embodiment, the circular panel **115** may include a port (not shown) for the inflation or deflation of the intragastric device **100**.

[0046] The size of the intragastric device **100** may be configured such that the entire intragastric device **100** may be insertable transorally through the esophagus and into the stomach without invasive surgery. In one embodiment, the intragastric device **100** may be inserted into the patient's stomach using a standard grabber. Alternatively, the deflated intragastric device **100** may be passed through an access tube placed down the esophagus, which may be lubricated for ease of passage.

[0047] Figure 2 shows an alternative intragastric device **140** similar to the flattened oval-shaped device **100** of Figure 1A but having two flat faces **142** connected for shape retention. There are a number of ways to do this; the illustrated embodiment shows a plurality of dimples **144** representing points at which the faces **142** are bonded together, such as by thermal welding. The result resembles upholstered buttons on a couch cushion. The plurality of dimples define points at which the opposed faces **142** are connected to each other through an inner cavity. Figure 3 shows the device **140** implanted within the stomach. Because of the points of connection between the two flat faces **142**, the device **140** better maintains its flattened configuration when inflated and thus better reshapes the stomach cavity. Although not shown, exterior grooves or internal flow passages may be provided through the device to permit passage of food through the stomach. Further, the external surfaces may further include stimulation features such as rounded bumps or protrusions, quill-like extensions, dimples or recesses, and the like, as described below. Upon contact with the inner stomach wall of the patient these irregularities may trigger hormone release or otherwise aid the patient in feeling full.

[0048] Another alternative satiety-inducing device **200** is shown in Figures 4-5, and comprises a solid member in the form of a ring that “planarizes” or flattens the stomach. Satiety is achieved by a two-fold effect: reducing the stomach volume and contacting gastric nerves. The amount of food ingested is restricted, as this device “planarizes” the stomach which decreases the stomach’s effective volume and capacity. Since there is less room for food, appetite is suppressed earlier than normal, thus reducing calorie consumption. In addition to reducing consumption potential, early feelings of satiety are also created from the “spring-like” memory retention of the loop that exerts a pressure on the stomach walls. It is believed that gastric nerves respond to pressure applied against the stomach walls in various positions, thus signaling the brain to release hormones that send a signal of satiety.

[0049] Referring to Figure 4, the satiety-inducing loop **200** is shown in a straightened configuration for transoral introduction into the body. The device **200** includes an elongated tubular body **202** having a head end **204**, a tail end opening **206**, and two opposed slotted body openings **208** adjacent the tail end. The head end **204** defines a flattened barbed head **210** and an opening **212** in a tip thereof. As shown, one end of a tether **214** fastens inside the head end **204**, while the majority of the tether extends out of the opening **212** and traverses the outside of the body **202**, passing into the end opening **206** and then exiting the body opening **208**. A spring **216** placed inside the formed tube provides the formed loop **200** with resiliency and prevents kinking. A second embodiment of this invention has no spring inside the tube, otherwise it is configured identically. This configuration is dependent upon arriving at a material having properties that are both stable in the acidic stomach environment for over one year, and also possesses a true spring-like “memory” retention of its own.

[0050] The satiety-inducing loop **200** may be easily implanted inside the patient transorally, without invasive surgery (and without the corresponding patient risks inherent in a surgery) and with a minimal recovery time since no extensive tissue healing is required. While in a substantially straight state, as in Figure 4, the satiety-inducing loop **200** may be inserted through a patient’s mouth, down the esophagus and into the stomach while keeping a portion of the string outside the patient’s mouth. A standard grabber may be used during the implantation process to assist implantation of loop **200**, or the straightened loop **200** may be passed through an access tube placed down the esophagus, which may be lubricated for ease of passage. After the loop **200** is inside the patient’s stomach and held in place by the grabber, the physician may pull on the tether **214** to bring the head end **204** to the end opening **206**. By continuing to pull on the tether **214**, the head end **204** enters end opening **206** and the flaps of arrow-shaped head

210 exits body opening **208**, which locks the head end **204** inside the end opening **206**, as seen in Figures 5 and 5A, thus forming a substantially circular loop. The physician then cuts the tether **214** once the loop **200** is formed, and any remaining tether inside the body may be disintegrated or digested by the juices inside the stomach. Accordingly, the string may be constructed out of a non-toxic substance.

[0051] The body **202** of the satiety-inducing loop **200** may be constructed out of polypropylene or other suitable materials for resisting the acidity of the stomach environment. For instance, the satiety-inducing loop **200** may be fabricated by heating either by heating and stretching areas of a plastic tube to be cut in two, so they form two smaller diameter areas that fit inside the large ID, or the smaller areas can be formed by a calibrated differential extrusion process. After sizing and cutting to length, the “arrow”-shaped head end **204** can be heated and stamped into shape with a die. A pre-formed spring **216**, if needed for the first embodiment, can then be inserted into the tube. During the arrow-stamping operation, the string/tether **214** must be rolled at one end and inserted into the arrow, then threaded through the opposite end and out a side hole.

[0052] In one aspect, the diameter of the loop **200** when in its implanted state is configured to fit the patient’s stomach while causing some reshaping thereof. While shown in a substantially circular design, the satiety-inducing loop **200** may be configured to take on any shape, including ovals, quadrilaterals, triangles, and even uncommon or random shapes (where the non-circular shaped loops may include joints that snap into place during the insertion process when the string is pulled). If circular, the diameter of the formed loop **200** is desirably between about 15-16 cm.

[0053] The satiety-inducing loop **200** may be configured to be easily removed by a standard grabber. By utilizing the grabber to squeeze the opposing ends of the arrow of the head **210** so that they align with the slot **208**, the head **210** may slip back out of the slot, causing it to gently spring back to its original, straight state. Then, using the grabber that is already inserted, the satiety-inducing loop **200** may be grasped and removed back up the esophagus and out the patient’s mouth. By adding a radio-opaque additive into the material of the arrow, the head **210** may be seen by an x-ray machine during the removal process.

[0054] Figure 6 is a perspective view of a further intragastric obesity treatment device **250** in place within the stomach in the shape of an open resilient coil capable of altering the shape of the stomach cavity. The device **250** generally forms a generally circular coil is shown having a diameter sufficient to extend from approximately the cardia **C** at the upper end of the stomach to

the antrum **A** at the lower end. For instance, the diameter of the coiled device **250** is desirably between about 15-16 cm.

[0055] With reference also to Figures 7A-7B, the obesity treatment device **250** preferably comprises an inner pre-formed wire **252** placed inside a soft and fairly flexible plastic tubular sheath **254**. Two open ends of the sheath **254** are closed with hard plastic, domed end caps **256** that also trap each end of the wire **252**. That is, each of the domed end caps **256** preferably includes a small hole that receives one end of the wire **252**, which can be secured therein with adhesive or the like. In one embodiment, the diameter of the sheath **254** has a diameter small enough to fit through a delivery tube (not shown) of about 19-20 mm. The domed end caps **256** have a maximum diameter approximately equal to the diameter of the sheath **254**, thus providing a smooth junction therebetween. The relatively soft and rounded configuration of the sheath **254** and domed end caps **256** prevents trauma to the stomach walls from the wire **252**. The assembled components of the device **250** are preferably coated with a flexible compound that is resistant to stomach juices. This coating, which may be dipped or sprayed on and then post-hardened, is also intended to fully seal the device against fluid ingress. Such a coating will desirably be an elastomeric polymer that will withstand the acidic environment and biological contaminants of the stomach.

[0056] In one embodiment, the wire **252** comprises Nitinol shaped in a tight spiral and having partially overlapping ends **258**. The wire **252** acts like a flat spring so that when compressed by peristaltic action of the stomach, it is inclined to return to its initial shape, thus applying outward pressure. Squeezing the device **250** on the outside will tend to make the coiled ring momentarily smaller, but compression in the direction along the axis of the coil we have no noticeable effect.

[0057] An alternative embodiment of the device **250** comprises a solid, coiled rod, rather than a wire positioned within an outer sheath. To help prevent trauma to the stomach walls, the ends of a solid rod may be capped with bulbs or other such rounded or enlarged members. In a still further embodiment, a Nitinol wire such as the wire **252** above may be coated with or embedded within a polymer to increase the exterior dimension and provide atraumatic ends. For instance, the device **250** shown above may be constructed this way so that there are no hollow spaces defined within.

[0058] As before, the obesity treatment device **250** is intended to be transorally placed, without the need for laparoscopic or other surgical assist, and without any need for piercing or cutting of tissues or physically anchoring the device. The coiled device **250** can freely float,

moving as the stomach moves. The outward spring action of the coil **250** is meant to apply pressure to infinitely variable areas of the stomach walls causing all-over stimulation.

[0059] Insertion and removal of the obesity treatment device **250** can be done repeatedly. The device **250** relies on the physical property of the internal Nitinol wire to straighten out, then instantly returned to its pre-formed shape. Over-stressing of Nitinol in this configuration is highly unlikely, even when acted upon by repeated, often extreme movement of the stomach. On the other hand, regular stainless steel or other such spring wire might deform when over-stressed by the stomach, or from straightening as needed for insertion/removal.

[0060] Additionally, a number of the devices described herein can be made rotationally variant, such that movement within the stomach results in certain arbitrary rotational adjustments which causes the device to occupy a different 3-dimensional space and orientation. This encourages different stimulation points as the device moves in the stomach, limiting the ability of the stomach to adapt over long term implantation.

[0061] Figure 8 illustrates another embodiment of an intragastric device **280** of the present application that is rotationally variant. As shown, the intragastric device **280** has a plurality of protrusions **285** or generally spherical “bumps” formed outwards from a center region of the intragastric device **280**. While the intragastric device **280** may be sized to fit comfortably inside the patient’s stomach, each of the plurality of protrusions **285** may be sized such that it blocks the patient’s pylorus temporarily when the protrusion **285** comes into contact with the pylorus, thereby slowing gastric emptying and allowing the patient to feel full for a longer period of time without the protrusion **285** getting stuck or wedged into the pylorus. In addition, the configuration of the intragastric device **280** may produce variations in how the intragastric device **280** sits or rotates inside the patient’s stomach. The overall exterior shape of the device is somewhat spherical, encouraging rotation. However, the outwardly projecting spheres that make up the device contact the stomach wall at different locations as the device rotates. Normal stomach contractions thus cause the intragastric device **280** to move around or rotate about the stomach, and due to the device’s configuration, different points on the inner stomach walls may be stimulated, thereby limiting the stomach’s ability to adapt over a long period of time. The protrusions **285** may be added to a number of the devices described herein.

[0062] In one embodiment, the protrusions **285** may be placed in an asymmetrical pattern to further limit the ability of the stomach to adapt over a long period of time.

[0063] The intragastric device **280** may be constructed of rubbers, fluorosilicones, fluoroelastomers, thermoplastic elastomers or any combination thereof to improve the durability of the intragastric device **280** inside the patient's stomach. However, the intragastric device **280** may be constructed of a continuous, thin, depressable wall and be hollow inside (filled with air/inert gas) to keep the intragastric device **280** light. Alternatively, the intragastric device **280** may be filled with a liquid gel such as silicon. The material(s) utilized to construct the intragastric device **280** may allow for a thinner wall thickness and have a lower coefficient of friction. Thinner walls and the lower coefficient of friction allow improved natural passage of the intragastric device **280** through the gastrointestinal tract should the intragastric device **280** deflate for any reason inside the patient's stomach.

[0064] While not shown, the outer surface of the intragastric device **280** may further include additional stimulation features such as even smaller rounded bumps or protrusions formed on the protrusions **285** (e.g., 10-15 mini-protrusions on each of the six protrusions shown in Figure 8, equally spread apart and having a substantially similar shape, but with a smaller diameter as compared to the protrusion **285**), quill-like extensions, dimples or recesses, and the like. These features, upon contact with the inner stomach wall of the patient may further trigger hormone release or otherwise aid the patient in feeling full.

[0065] Figure 9 illustrates another embodiment of the intragastric device **300**. As shown, the intragastric device **300** has four "legs" **305** terminating in rounded or bulbous ends **310**. The configuration of the four legs may be asymmetrical as shown. If divided into "the top two legs" and "the bottom two legs", the "pairs of legs" appear joined at the center and "twisted 90 degrees" to form the configuration as shown. However, this is merely one example of any of a plurality of configurations for any of a plurality of leg numbers.

[0066] For example, additional legs may be attached or removed, and/or the configuration may be altered. In addition, each leg portion **305** terminate in the bulbous ends **310**. The ends **310**, as shown, cap the end of the leg portion **305** and each has a diameter substantially thicker than the diameter of the leg portion **305**. Accordingly, the ends **310** may be sized such that it blocks the patient's pylorus temporarily when the ends **310** comes into contact with the pylorus, and thereby slowing gastric emptying and allowing the patient to feel full for a longer period of time without the ends **310** getting stuck or wedged into the pylorus. Again, the device **300** rotates relatively easily within the stomach, especially upon peristaltic motion, and the separated legs **305** and ends **310** therefore contact the stomach wall at different locations on a constantly changing basis. Normal stomach contractions may cause the intragastric device **300** to move

around or rotate about the stomach, and due to the device's configuration, different points on the inner stomach walls may be stimulated, thereby limiting the ability of the stomach to adapt over a long period of time. These features can be utilized in a device that looks like the device **300**, or can be added to a number of the embodiments described herein, such as the inflated member **100** of Figures 1A-1D.

[0067] The intragastric device **300** may be constructed of rubbers, fluorosilicones, fluoroelastomers, thermoplastic elastomers or any combination thereof to improve the durability of the intragastric device **300** inside the patient's stomach. However, the intragastric device **300** may be constructed of a continuous, thin, depressable wall and be hollow inside (filled with air/inert gas) to keep the intragastric device **300** light. Alternatively, the intragastric device **300** may be filled with a liquid gel such as silicon. The materials utilized may allow for a thinner wall thickness and have a lower coefficient of friction. Thinner walls and the lower coefficient of friction allows improved natural passage of the intragastric device **300** through the gastrointestinal tract should the intragastric device **300** deflate for any reason inside the patient's stomach.

[0068] While not shown, the outer surface of the intragastric device **300** may further include additional stimulation features such as even small rounded bumps or protrusions formed on the ends **310** (e.g., 10-15 mini-protrusions on each of the four ends shown in Figure 9, equally spread apart and having a substantially similar shape, but with a much smaller diameter as compared to the ends **310**), quill-like extensions, dimples or recesses, and the like. These features, upon contact with the inner stomach wall of the patient may further trigger hormone release or otherwise aid the patient in feeling full.

[0069] Another option for a number of the intragastric devices disclosed herein is to add exterior stimulation features, such as any raised or depressed geometry which act to stimulate certain portions of the stomach walls. Such features may be particularly effective for those embodiments which stimulate the cardia.

[0070] Figure 10 illustrates another embodiment of the intragastric device **400**. As shown, the intragastric device **400** is a substantially spherical object with protrusions or bumps **405** extending outward from the surface of the intragastric device **400**. As shown, a plurality of protrusions **405** may be equally spaced apart on the outer surface and interspersed with flat portions **410**. In one embodiment, the protrusions **405** do not contact each other. In another embodiment, the protrusions **405** may be of equal heights and diameters. However, the protrusions **405** may be configured to contact each other (and thereby creating space and

allowing for more protrusions **405** to be added to the surface). In another embodiment, the protrusions **405** may be configured to have different heights and/or diameters. For example, having protrusions with different heights and/or diameters may be advantageous for preventing the stomach from adjusting to the protrusions **405**. The protrusions **405** separately contact the inner walls of the stomach, potentially increasing the stimulation to the surrounding satiety-sensing nerves.

[0071] In another embodiment, the size of the intragastric device **400** may be altered. For example, in a uni-intragastric device system, one intragastric device **400** may be implanted into the patient's stomach, and the single intragastric device may be sized accordingly to fit comfortably inside the patient's stomach. However, it is also possible to employ multiple, smaller devices, such as 2 or 3 objects similar to the intragastric device **400**. Under this multi-intragastric device system, each intragastric device **400** may be sized such that it blocks the patient's pylorus temporarily when the intragastric device **400** comes into contact with the pylorus, and thereby slowing gastric emptying and allowing the patient to feel full for a longer period of time (and also to prevent intestinal blockage). In addition, the configuration of the intragastric device **400** may produce variations in how the intragastric device **400** sits or rotates inside the patient's stomach. Normal stomach contractions may cause the intragastric device **400** to move around or rotate about the stomach, and due to the device's configuration, different points on the inner stomach walls may be stimulated, thereby limiting the ability of the stomach to adapt over a long period of time.

[0072] The intragastric device **400** may be constructed of rubbers, fluorosilicones, fluoroelastomers, thermoplastic elastomers or any combination thereof to improve the durability of the intragastric device **400** inside the patient's stomach. However, the intragastric device **400** may be constructed of a continuous, thin, depressable wall and be hollow inside (filled with air/inert gas) to keep the intragastric device **400** light. Alternatively, the intragastric device **400** may be filled with a liquid gel such as silicon. Regardless, the materials utilized may allow for a thinner wall thickness and have a lower coefficient of friction. Thinner walls and the lower coefficient of friction allows improved natural passage of the intragastric device **400** through the gastrointestinal tract should the intragastric device **400** deflate for any reason inside the patient's stomach.

[0073] While not shown, the outer surface of the intragastric device **400** may further include additional stimulation features such as even small rounded bumps or protrusions formed on the protrusions **405** (e.g., 10-15 mini-protrusions on each of the protrusions **405** of Figure 10,

equally spread apart and having a substantially similar shape, but with a much smaller diameter as compared to the protrusions **405**), quill-like extensions, dimples or recesses, and the like. These features, upon contact with the inner stomach wall of the patient may further trigger hormone release or otherwise aid the patient in feeling full.

[0074] Figure 11 illustrates another embodiment of the intragastric device **500**. As shown, the intragastric device **500** is a substantially spherical object with long flagella or quill-like extensions **505** extending outward from the outer surface of a central region of the intragastric device **500**. As shown, a plurality of extensions **505** may be equally spaced apart. In one embodiment, the extensions **505** do not contact each other. In another embodiment, the extensions **505** may be of equal heights and diameters. However, the extensions **505** may be configured to contact each other (and thereby creating space and allowing for more extensions **505** to be added to the surface). In another embodiment, the extensions **505** may be configured to have different heights and/or diameters. For example, having protrusions with different heights and/or diameters may be advantageous for preventing the stomach from adjusting to the extensions **505**. In one embodiment, the extensions may be extremely flexible and may bend when a pressure is exerted on the extensions **505** from the inner stomach wall of the patient. Alternatively, the extensions **505** may be stiffer and might not bend as much when a pressure is exerted on the extensions **505** from the inner stomach wall of the patient. In another embodiment, some of the extensions **505** may have a first flexibility while some of the extensions may have a second flexibility. Alternatively, the extensions **505** may be uniformly flexible. In other words, any flexibility of the extensions may be utilized with the intragastric device **500**.

[0075] In another embodiment, the size of the intragastric device **500** may be altered. For example, in a uni-intragastric device system, one intragastric device **500** may be implanted into the patient's stomach, and the single intragastric device may be sized accordingly to fit comfortably inside the patient's stomach. However, it is also possible to employ multiple, smaller devices, such as 2 or 3 objects similar to the intragastric device **500**. Under this multi-intragastric device system, each intragastric device **500** may be sized such that it blocks the patient's pylorus temporarily when the intragastric device **500** comes into contact with the pylorus, and thereby slowing gastric emptying and allowing the patient to feel full for a longer period of time (and also to prevent intestinal blockage). In addition, the configuration of the intragastric device **500** may produce variations in how the intragastric device **500** sits or rotates inside the patient's stomach. Normal stomach contractions may cause the intragastric device

500 to move around or rotate about the stomach, and due to the device's configuration, different points on the inner stomach walls may be stimulated, thereby limiting the ability of the stomach to adapt over a long period of time. In another embodiment of the multi-intragastric device system, different intragastric devices may be implanted into the same patient's stomach at the same time. For example, the intragastric device of Figure 10 and the intragastric device of Figure 11 may both be implanted in the patient and may simultaneously work together. One benefit of this approach may be that the stomach will have an even more difficult time adjusting to the intragastric devices **400** and **500** since they are completely different from one another, thereby improving the efficacy of the system.

[0076] Referring back to Figure 11, the intragastric device **500** may be constructed of rubbers, fluorosilicones, fluoroelastomers, thermoplastic elastomers or any combination thereof to improve the durability of the intragastric device **500** inside the patient's stomach. However, the intragastric device **500** may be constructed of a continuous, thin, depressable wall and be hollow inside (filled with air/inert gas) to keep the intragastric device **500** light. Alternatively, the intragastric device **500** may be filled with a liquid gel such as silicon. Regardless, the materials utilized may allow for a thinner wall thickness and have a lower coefficient of friction. Thinner walls and the lower coefficient of friction allows improved natural passage of the intragastric device **500** through the gastrointestinal tract should the intragastric device **500** deflate for any reason inside the patient's stomach.

[0077] Figure 12A illustrates another embodiment of the intragastric device **600**. As shown, the intragastric device **600** is a substantially spherical object with recesses or dimples **605** extending inward from the surface of the intragastric device **600**. In one embodiment, the intragastric device **600** may be considered to have a surface comprised of recesses **605** and flat portions **610**. As shown, a plurality of recesses **605** may be equally spaced apart on the outer surface. As shown, recesses **605** do not contact each other, and may be of equal heights and diameters. In addition to being depressed, the recesses **605** may employ a thinner wall. For example, if the flat portions **610** have a wall thickness of 20 millimeters, the recesses **605** may have a wall thickness of 10 millimeters. With a thinner wall, the recesses **605** may be more susceptible to larger strains.

[0078] The intragastric device **600** is effectively triggered in the patient's stomach by stomach contractions. These stomach contractions increase the pressure in the intragastric device **600**. Figure 12B illustrates a close up view of the recesses **605** and the flat portions **610**. If the recess **605** is not in contact with the stomach wall or some outside retaining force, the

recess **605** with the thinner walls will deform until the recess **605** comes into contact with the stomach wall or comes under the influence of some other outside force. The recess **605** will also stop deforming when no contact is made when the modulus of the material forming the recess is such that the stress in the material is balanced with the internal pressure of the intragastric device **600**.

[0079] Now, if the recess **605** is in contact with the stomach wall, the pressure exerted on the recess **605** may cause it to inflate outward and exert a disproportionately larger force on the stomach wall (as compared to the immediate surround area, e.g., the non-recessed, flat portions **610**).

[0080] In another embodiment, the size of the intragastric device **600** may be altered. For example, in a uni-intragastric device system, one intragastric device **600** may be implanted into the patient's stomach, and the single intragastric device may be sized accordingly to fit comfortably inside the patient's stomach. However, it is also possible to employ multiple, smaller devices, such as 2 or 3 objects similar to the intragastric device **600**. Under this multi-intragastric device system, each intragastric device **600** may be sized such that it blocks the patient's pylorus temporarily when the intragastric device **600** comes into contact with the pylorus, and thereby slowing gastric emptying and allowing the patient to feel full for a longer period of time (and also to prevent intestinal blockage). In addition, the configuration of the intragastric device **600** may produce variations in how the intragastric device **600** sits or rotates inside the patient's stomach. Normal stomach contractions may cause the intragastric device **600** to move around or rotate about the stomach, and due to the device's configuration, different points on the inner stomach walls may be stimulated, limiting the ability of the stomach to adapt over a long period of time.

[0081] The intragastric device **600** may be constructed of rubbers, fluorosilicones, fluoroelastomers, thermoplastic elastomers or any combination thereof to improve the durability of the intragastric device **600** inside the patient's stomach. In one embodiment, the flat portions **610** and the recesses **605** may be constructed of different materials. For example, the flat portions **610** may be made of one material with one mechanical property (e.g., a rubber) while the recesses **605** may be constructed of a different material with a different mechanical property (e.g., a thermoplastic elastomer).

[0082] Alternatively, the intragastric device **600** may be constructed of a continuous, thin, depressable wall of the same material, but of different thicknesses (e.g., the flat portions **610** may be thicker than the recesses **605**). In one embodiment, the intragastric device **600** may be

hollow inside (filled with air/inert gas) to keep the intragastric device **600** light. Alternatively, the intragastric device **600** may be filled with a liquid gel such as silicon. The materials utilized may allow for a thinner wall thickness and have a lower coefficient of friction. Thinner walls and the lower coefficient of friction allows improved natural passage of the intragastric device **600** through the gastrointestinal tract should the intragastric device **600** deflate for any reason inside the patient's stomach.

[0083] While not shown, the outer surface of the intragastric device **600** may further include additional stimulation features such as small rounded bumps or protrusions formed on the flat portions **610**, quill-like extensions, and the like. These features, upon contact with the inner stomach wall of the patient may further trigger hormone release or otherwise aid the patient in feeling full.

[0084] The implantable devices described herein will be subjected to clinical testing in humans. The devices are intended to treat obesity, which is variously defined by different medical authorities. In general, the terms "overweight" and "obese" are labels for ranges of weight that are greater than what is generally considered healthy for a given height. The terms also identify ranges of weight that have been shown to increase the likelihood of certain diseases and other health problems. Applicants propose implanting the devices as described herein into a clinical survey group of obese patients in order to monitor weight loss.

[0085] For example, clinical studies on the coiled device **250** described above will be performed with the following parameters.

[0086] Components:

Tubular sheath **254**, Wire **252**, End caps **256**, Silicone dip coating around assembly,
Adhesive

[0087] Materials:

Tubular sheath **254**: Silicone rubber as defined by the Food and Drug Administration (FDA) in the Code of Federal Regulations (CFR) Title 21 §177.2600

Wire **252**: Nitinol

End caps **256**: Delrin homopolymer

Adhesive: Silicone 3166-01

[0088] Dimensions:

Tubular sheath **254**: 10.16-10.32 cm (4-8 inch) overall diameter, 1.27-1.91 cm (0.5-0.75 inch) tube diameter

[0089] Purposes:

the devices are for human implant,

the devices are intended to occupy gastric space while also applying intermittent pressure to various and continually changing areas of the stomach;

the devices are intended to stimulate feelings of satiety, thereby functioning as a treatment for obesity.

[0090] General implant procedures:

The device is intended to be implanted transorally via endoscope into the corpus of the stomach. The device is non-fixating and requires no inflation or further manipulation once deployed. When deployed the device morphology prevents dislodgement and ensures that it remains in the gastric cavity.

However, other modes of access are contemplated, such as surgical/ vascular access, various injection routes, percutaneous route, topical application, etc.

Implantation of the medical devices will occur via endoscopy.

Nasal/Respiratory administration of oxygen and isoflurane to be used during surgical procedures to maintain anesthesia as necessary.

[0091] One exemplary implant procedure is listed below.

- a) Perform preliminary endoscopy on the patient to examine the GI tract and determine if there are any anatomical anomalies which may affect the procedure and/or outcome of the study.
- b) Insert the introducer into the over-tube.
- c) Insert the gastroscope through the introducer inlet until the flexible portion of the gastroscope is fully exited the distal end of the introducer.
- d) Leading under endoscopic vision, gently navigate the gastroscope, followed by the introducer/over-tube, into the stomach.
- e) Remove gastroscope and introducer while keeping the over-tube in place.
- f) *OPTIONAL*: Place the insufflation cap on the over-tubes inlet, insert the gastroscope, and navigate back to the stomach cavity.

- g) *OPTIONAL*: Insufflate the stomach with air/inert gas to provide greater endoscopic visual working volume.
- h) Straighten the Coil, and insert fully into the over-tube.
- i) Under endoscopic vision, push the Coil into the stomach.
- j) Confirm deployment of the coil using visual confirmation. Ensure the tip of the coil has not entered the pylorus during delivery.
- k) Insert endoscopic grasping instrumentation to adjust the Coil position in the stomach as required.
- l) Perform final endoscopic inspection for any potential anomalies. Record all observations.
- m) Remove the gastroscope from over-tube.
- n) Remove the over-tube from the patient.

[0092] End Point Criteria:

- Weight Loss
- Comprehensive Metabolic Panel (CMP)
- HbA1C
- Lipid Panel
- Tissue Samples/Response

[0093] Unless otherwise indicated, all numbers expressing quantities of ingredients, properties, and so forth used in the specification and claims are to be understood as being modified in all instances by the term “about.” Accordingly, unless indicated to the contrary, the numerical parameters set forth in the specification and attached claims are approximations that may vary depending upon the desired properties sought to be obtained. At the very least, and not as an attempt to limit the application of the doctrine of equivalents to the scope of the claims, each numerical parameter should at least be construed in light of the number of reported significant digits and by applying ordinary rounding techniques.

[0094] Notwithstanding that the numerical ranges and parameters setting forth the broad scope of the disclosure are approximations, the numerical values set forth in the specific examples are reported as precisely as possible. Any numerical value, however, inherently contains certain errors necessarily resulting from the standard deviation found in their respective testing measurements.

[0095] The terms “a,” “an,” “the” and similar referents used in the context of describing the invention (especially in the context of the following claims) are to be construed to cover both the singular and the plural, unless otherwise indicated herein or clearly contradicted by context. Recitation of ranges of values herein is merely intended to serve as a shorthand method of referring individually to each separate value falling within the range. Unless otherwise indicated herein, each individual value is incorporated into the specification as if it were individually recited herein. All methods described herein can be performed in any suitable order unless otherwise indicated herein or otherwise clearly contradicted by context. The use of any and all examples, or exemplary language (e.g., “such as”) provided herein is intended merely to better illuminate the invention and does not pose a limitation on the scope of the invention otherwise claimed. No language in the specification should be construed as indicating any non-claimed element essential to the practice of the invention.

[0096] Groupings of alternative elements or embodiments of the invention disclosed herein are not to be construed as limitations. Each group member may be referred to and claimed individually or in any combination with other members of the group or other elements found herein. It is anticipated that one or more members of a group may be included in, or deleted from, a group for reasons of convenience and/or patentability. When any such inclusion or deletion occurs, the specification is deemed to contain the group as modified thus fulfilling the written description of all Markush groups used in the appended claims.

[0097] Certain embodiments are described herein, including the best mode known to the inventors for carrying out the invention. Of course, variations on these described embodiments will become apparent to those of ordinary skill in the art upon reading the foregoing description. The inventor expects skilled artisans to employ such variations as appropriate, and the inventors intend for the invention to be practiced otherwise than specifically described herein. Accordingly, this invention includes all modifications and equivalents of the subject matter recited in the claims appended hereto as permitted by applicable law. Moreover, any combination of the above-described elements in all possible variations thereof is encompassed by the invention unless otherwise indicated herein or otherwise clearly contradicted by context.

[0100] Furthermore, references may have been made to patents and printed publications in this specification. Each of the above-cited references and printed publications are individually incorporated herein by reference in their entirety.

[0101] Specific embodiments disclosed herein may be further limited in the claims using “consisting of” or “consisting essentially of” language. When used in the claims, whether as

filed or added per amendment, the transition term “consisting of” excludes any element, step, or ingredient not specified in the claims. The transition term “consisting essentially of” limits the scope of a claim to the specified materials or steps and those that do not materially affect the basic and novel characteristic(s). Embodiments of the invention so claimed are inherently or expressly described and enabled herein.

[0102] In closing, it is to be understood that the embodiments of the invention disclosed herein are illustrative of the principles of the present invention. Other modifications that may be employed are within the scope of the invention. Thus, by way of example, but not of limitation, alternative configurations of the present invention may be utilized in accordance with the teachings herein. Accordingly, the present invention is not limited to that precisely as shown and described.

AMENDED CLAIMS

received by the International Bureau on 21 June 2012 (21.06.12)

WHAT IS CLAIMED IS:

1. An intragastric obesity treatment implant that stimulates the stomach walls, comprising:

an inflatable member having an inflated size that will not pass through the pyloric sphincter and a volume within the stomach of at least 400 ml and being made of a material that will resist degradation over a period of at least six months within the stomach, the inflatable member being formed, in an inflated shape, as a substantially planar disc having opposed generally flat parallel panels and a peripheral surface and a maximum width larger than the contracted width of an adult stomach so alter the shape of the stomach to conform somewhat to the inflatable member, the planar disc being free-floating in the stomach without any appendages,

the implant being formed of a material which permits it to be compressed when deflated into a substantially linear delivery configuration.

2. The implant of claim 1, further including a plurality of dimples on each opposed panel of the substantially planar disc defining points at which the opposed panels are connected through an inner cavity to help retain the substantially planar disc shape.

3. The implant of claim 1, wherein the opposed panels and peripheral surface are smooth.

4. The implant of claim 1, wherein the opposed panels are generally circular with a diameter, and the peripheral surface defines a thickness that is less than one-half the diameter.

5. The implant of claim 1, at least some of the opposed panels and peripheral surface are irregular in a pattern selected from the group consisting of a rounded protrusion, a quill-like extension, a recess, and combinations thereof.

6. The implant of claim 1, wherein the intragastric device is constructed out of a material selected from a group consisting of a rubber, a fluorosilicone, a fluoroelastomer, a thermoplastic elastomer, and combinations thereof.
7. The implant of claim 1, wherein the inflatable member forms a wall-like divider in the stomach.
8. The implant of claim 1, wherein the peripheral surface is oval-shaped.
9. The implant of claim 8, wherein the long dimension of the oval-shaped peripheral surface is the maximum width of the planar disc.
10. The implant of claim 1, wherein the peripheral surface is an end panel substantially perpendicular to the opposed generally flat parallel panels.
11. The implant of claim 1, wherein the planar disc has a diameter of about 5-15 cm (2-6 inches) and a thickness which is one-half or less than the diameter.
12. The implant of claim 11, wherein the planar disc has a thickness between about 1.2-8 cm (0.5-3 inches), with the lower bound matching the lower bound of the diameter, and vice versa.
13. The implant of claim 1, wherein the planar disc has a diameter of about 10-15 cm (4-6 inches) and a thickness of between about 2-4 cm (0.75-1.6 inches), with the lower bound matching the lower bound of the diameter, and vice versa.
14. The implant of claim 1, wherein one end of the peripheral surface is flat with the rest being rounded.
15. The implant of claim 14, wherein the flat end of the peripheral surface includes a self-sealing inflation patch or fill valve.
16. The implant of claim 1, further including wherein the opposed panels are connected in their middle portions to help retain the substantially planar disc shape.

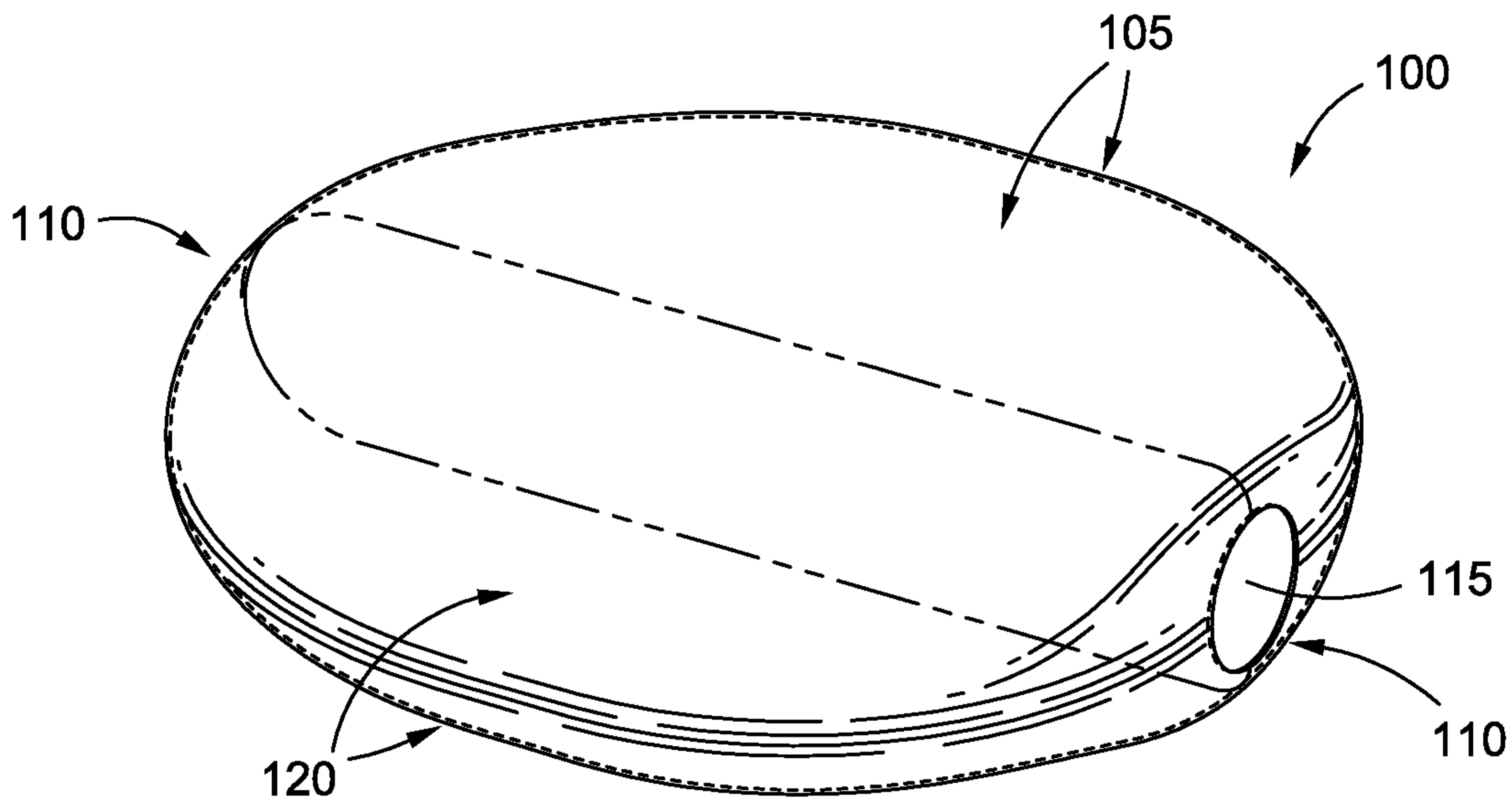

FIG. 1A

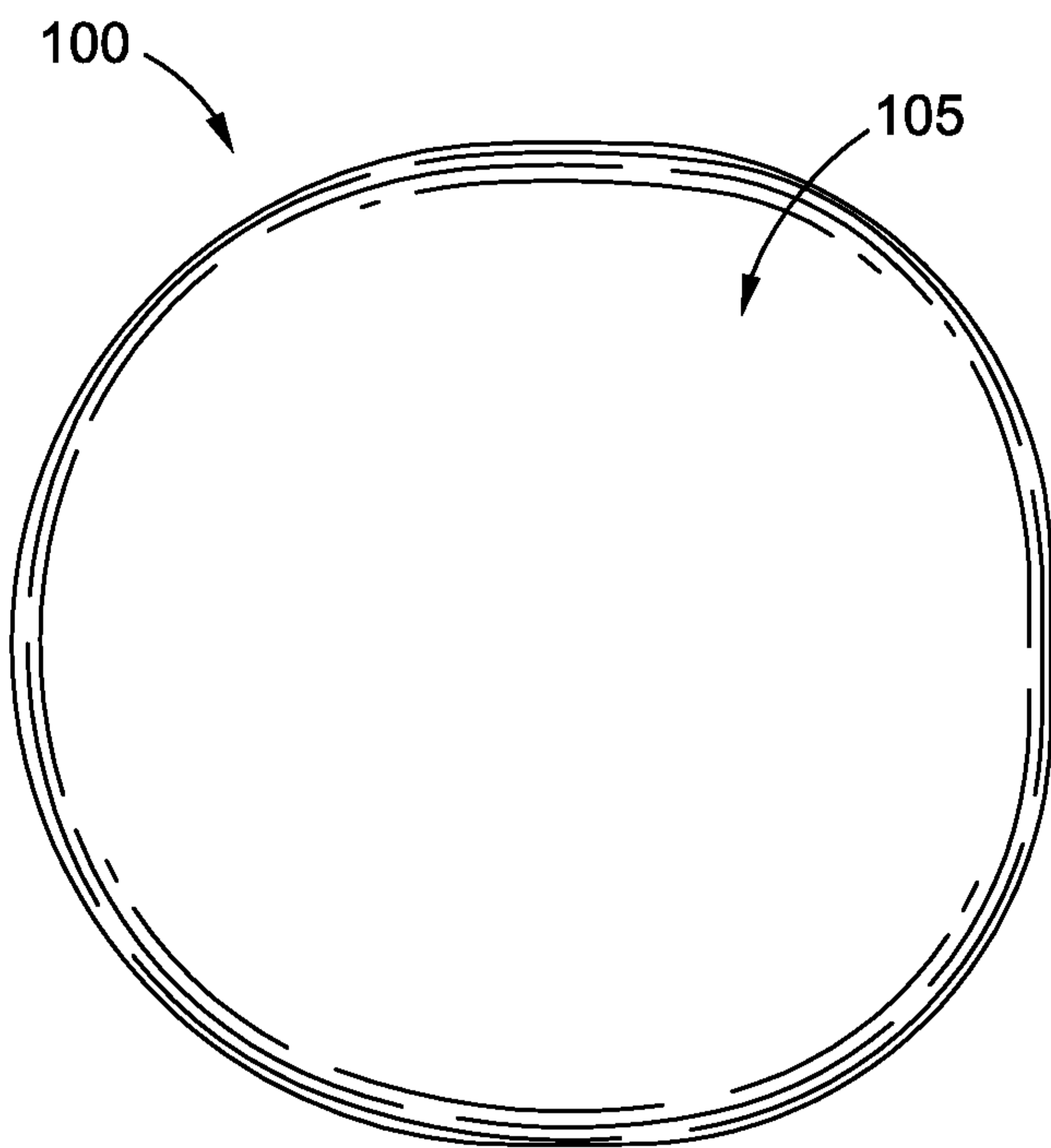

FIG. 1B

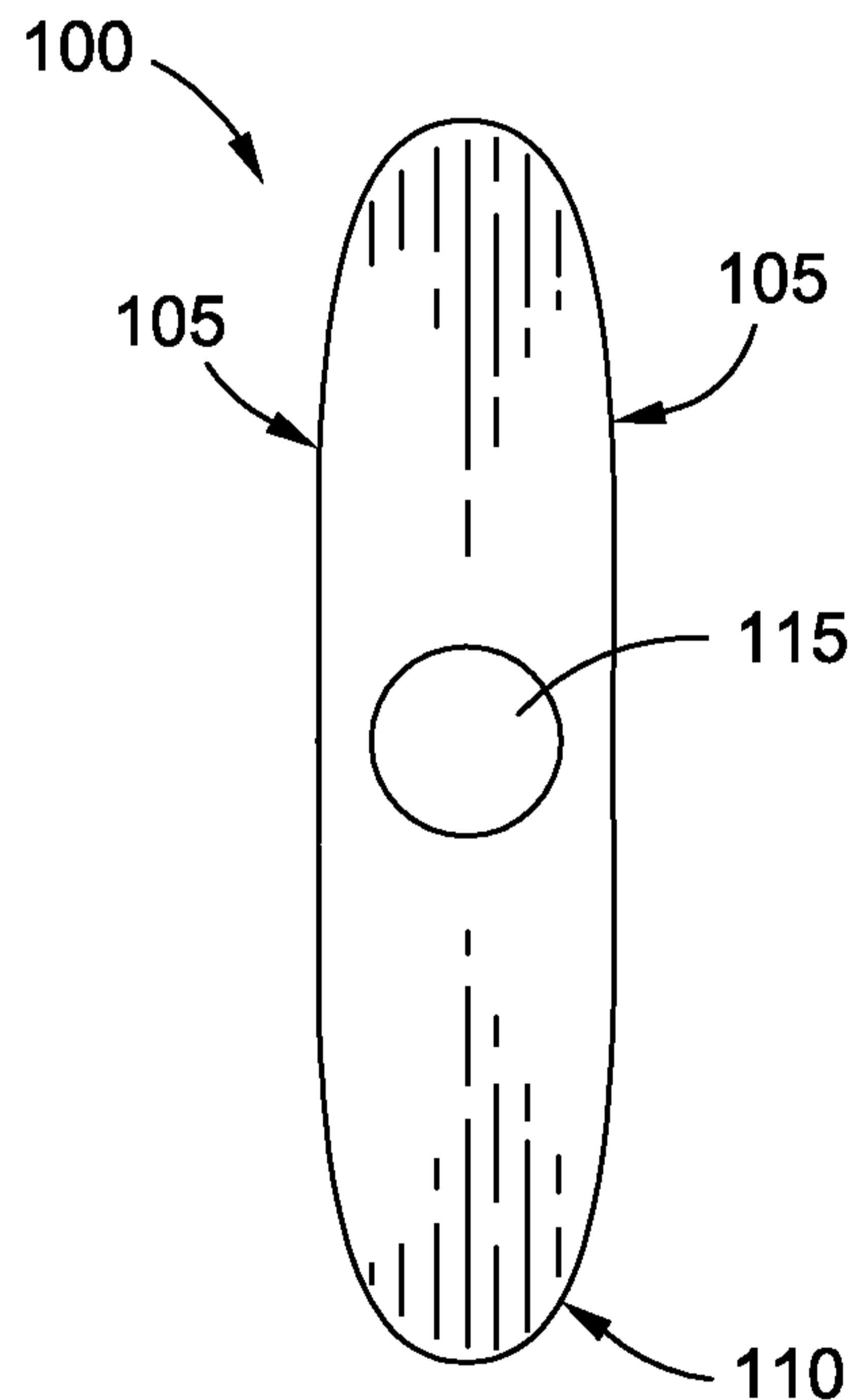

FIG. 1D

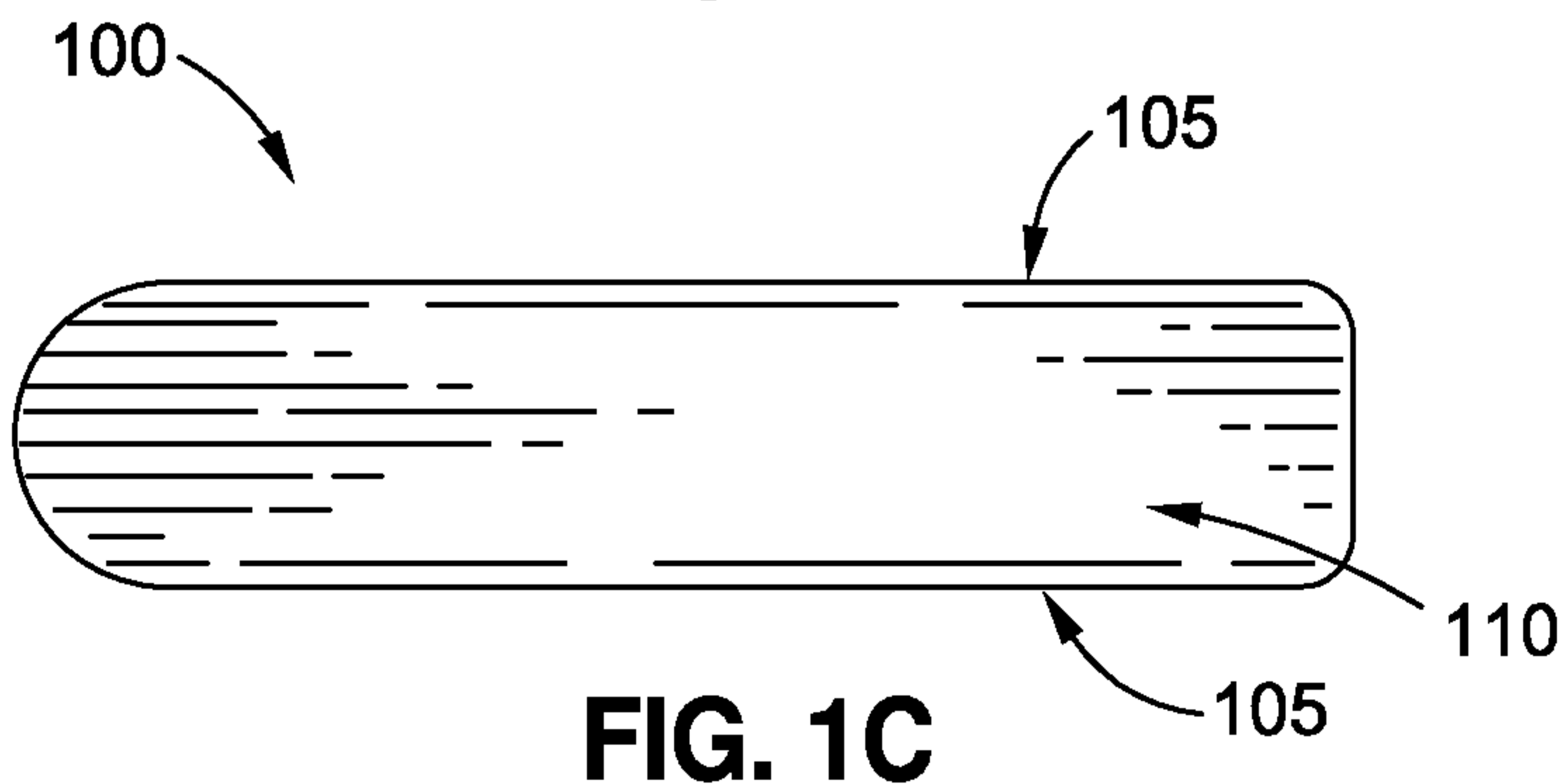

FIG. 1C

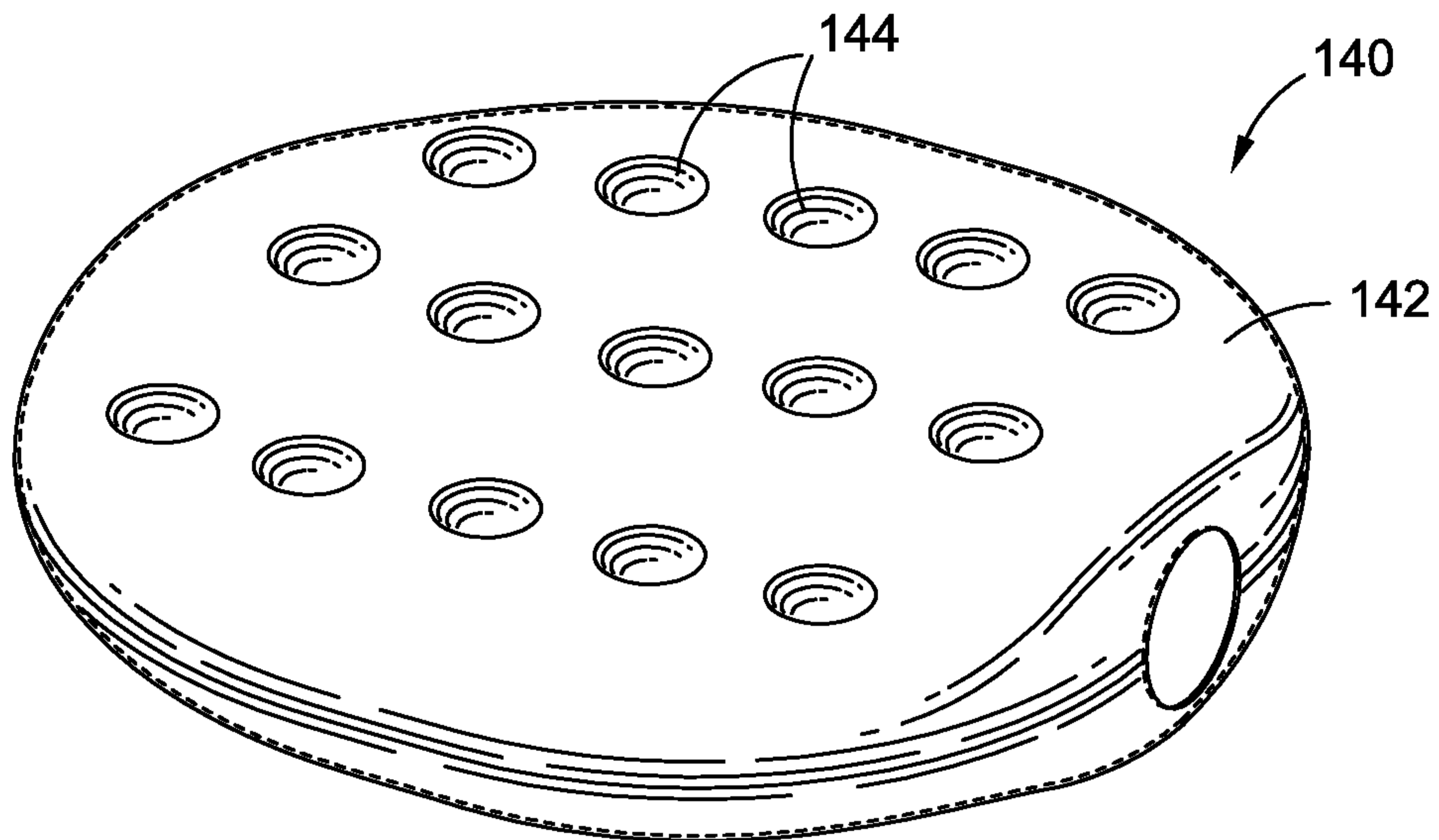

FIG. 2

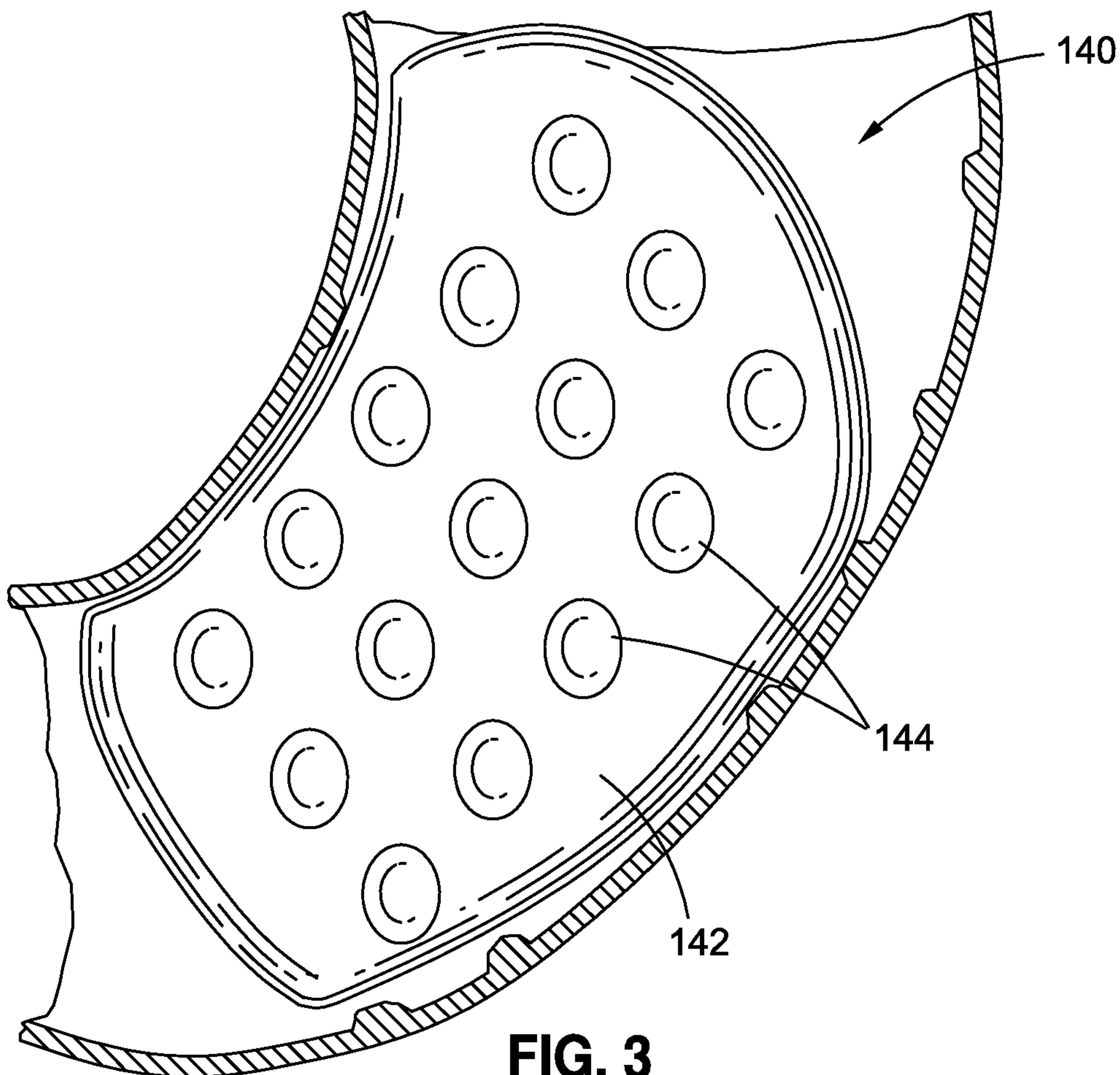

FIG. 3

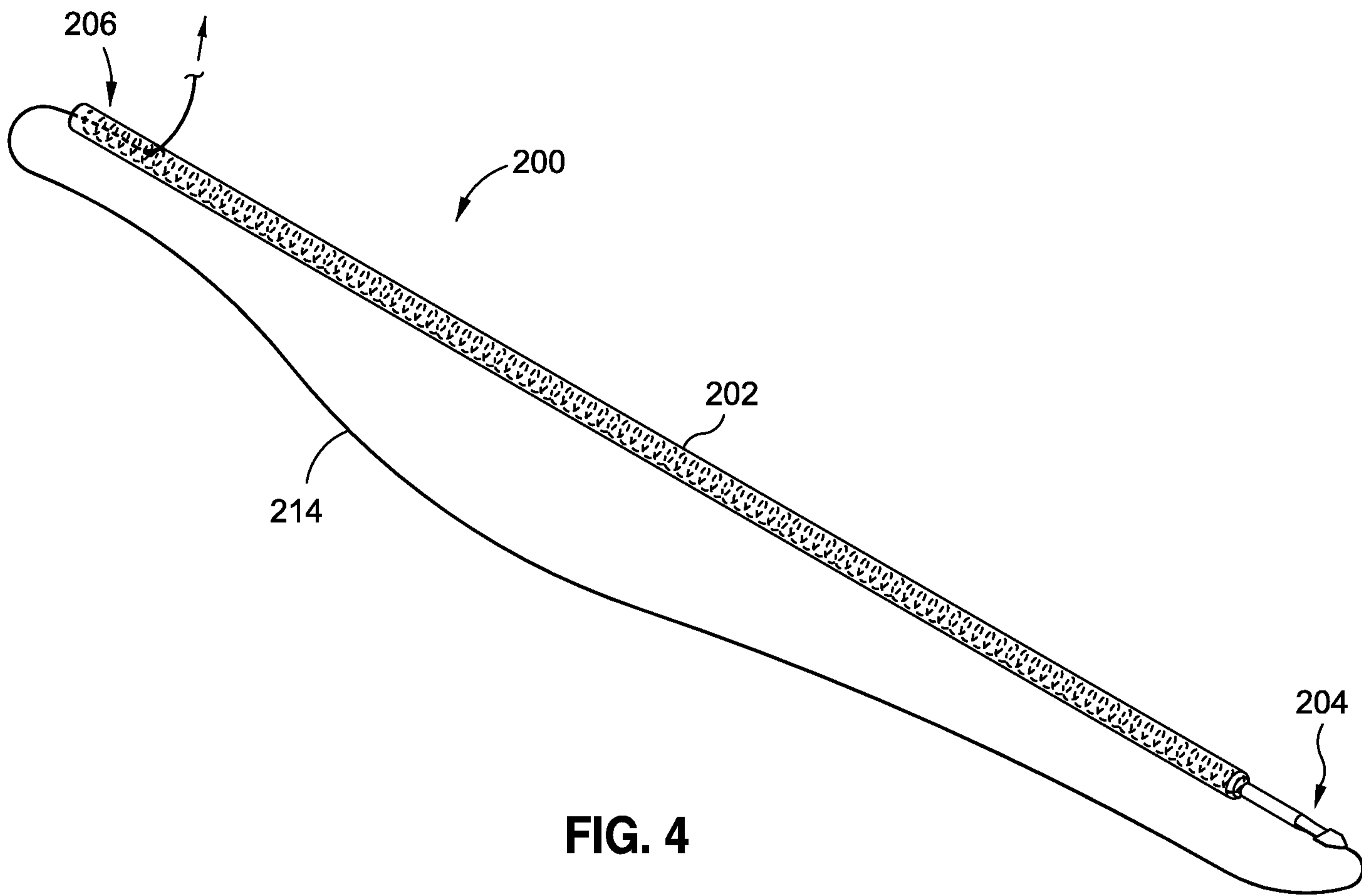

FIG. 4

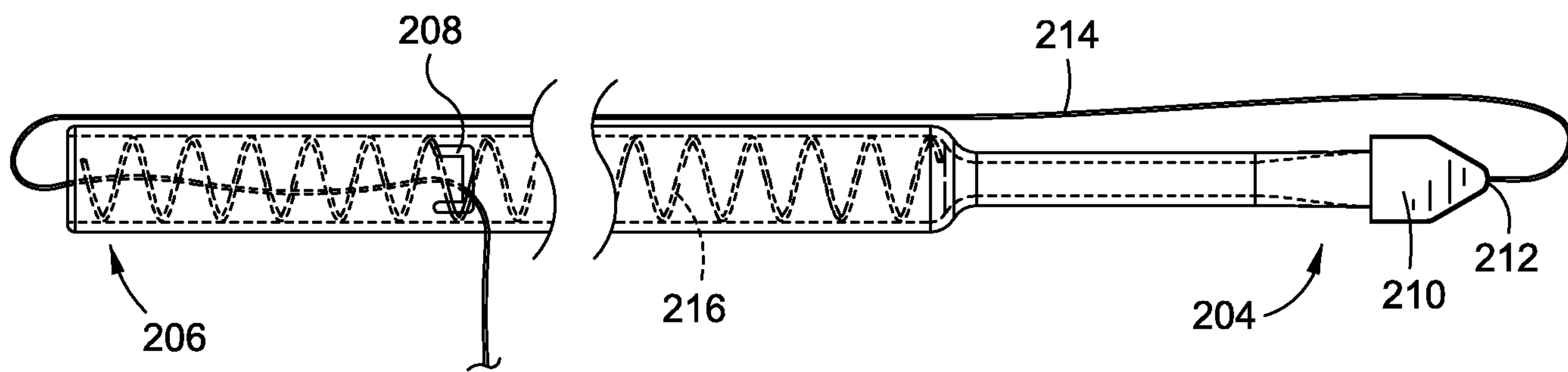

FIG. 4A

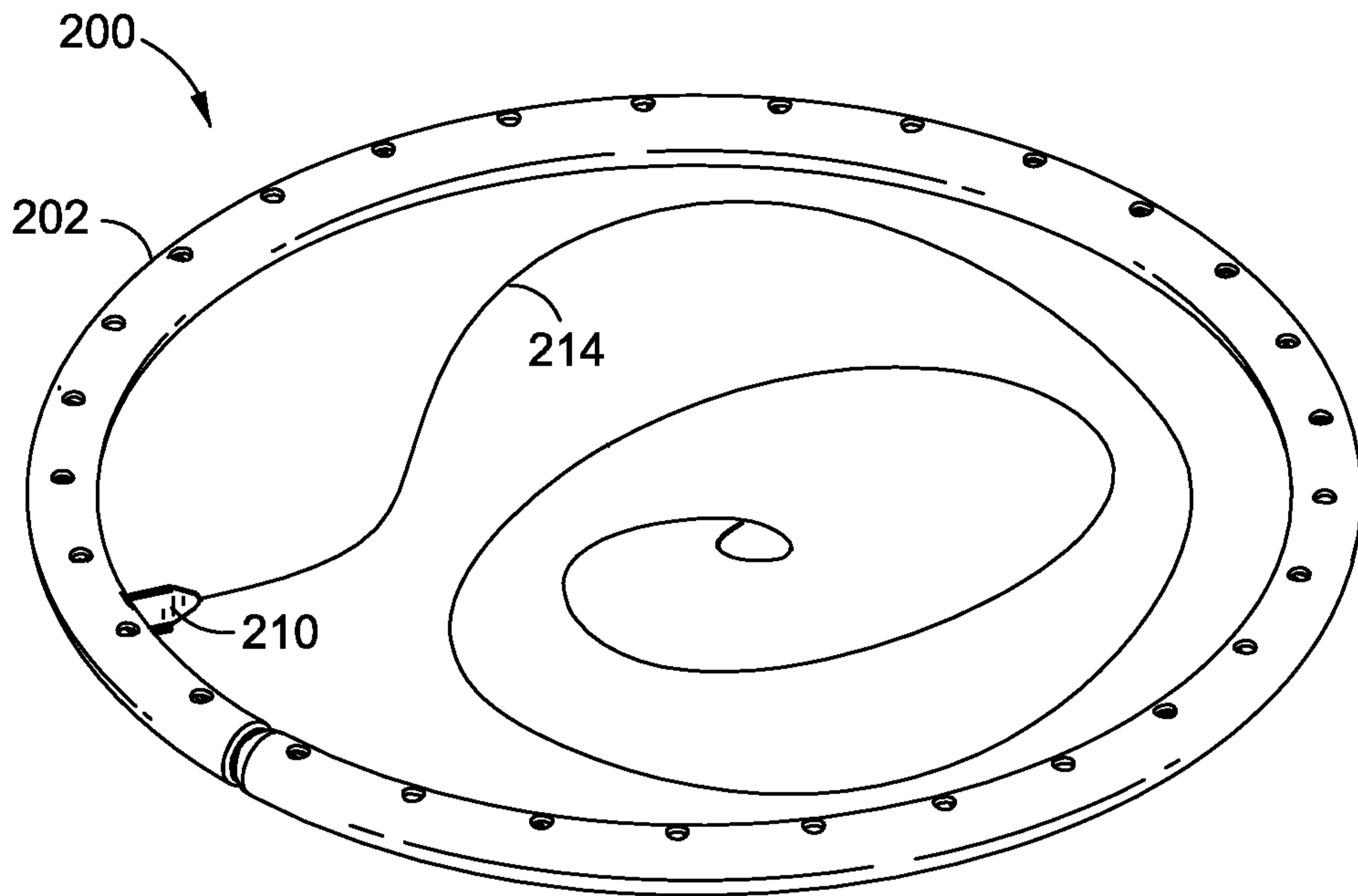

FIG. 5

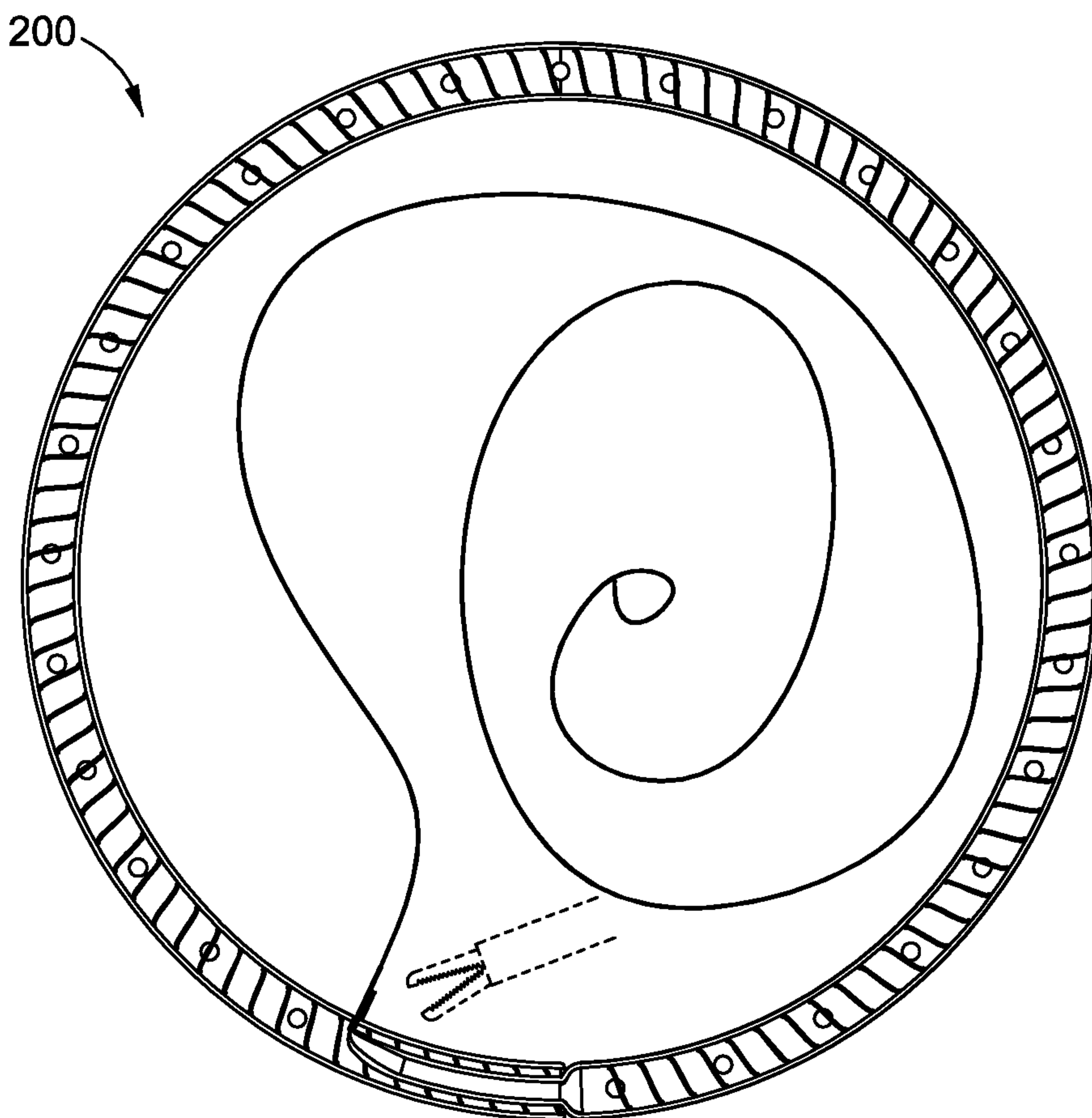

FIG. 5A

5/7

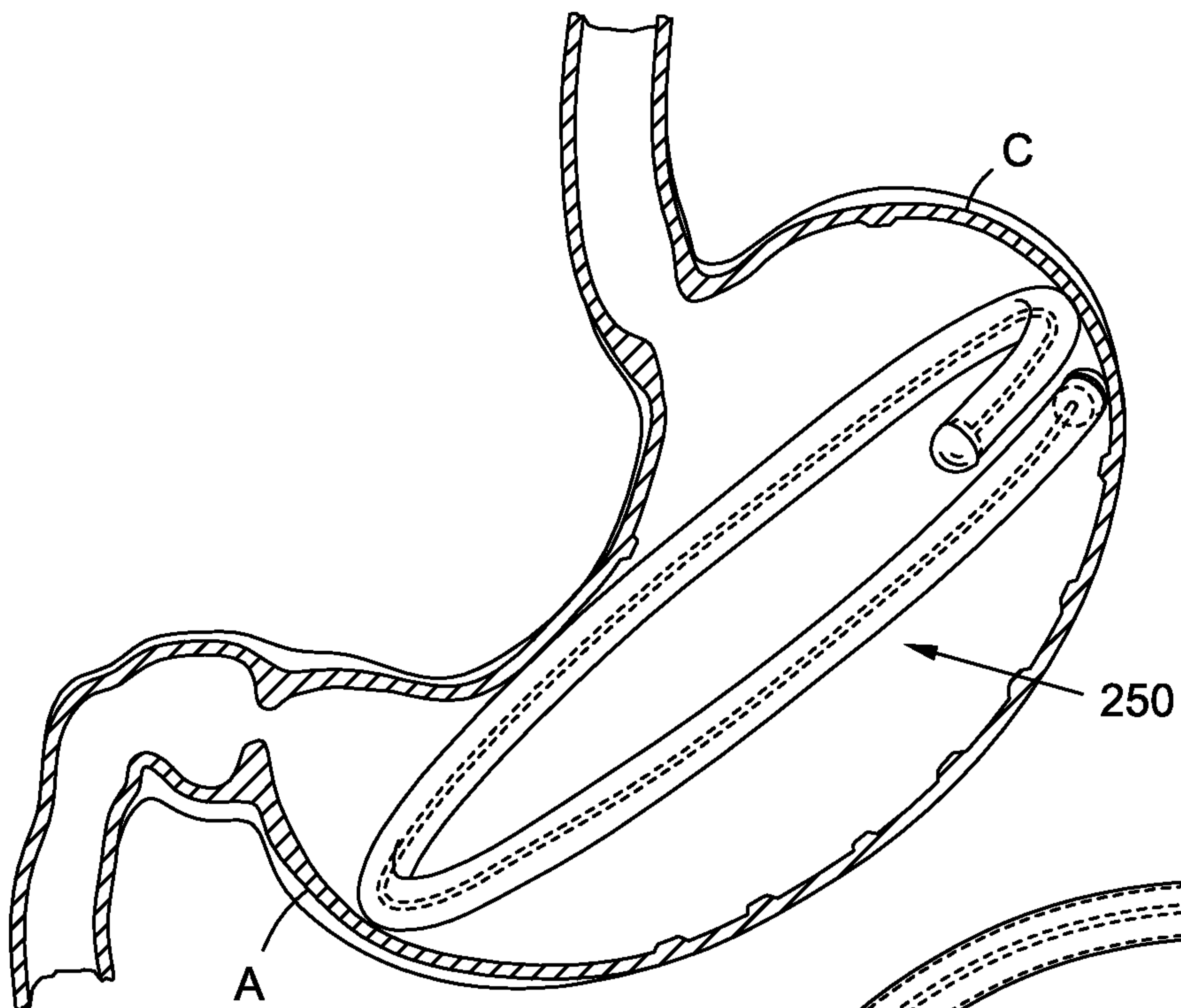

FIG. 6

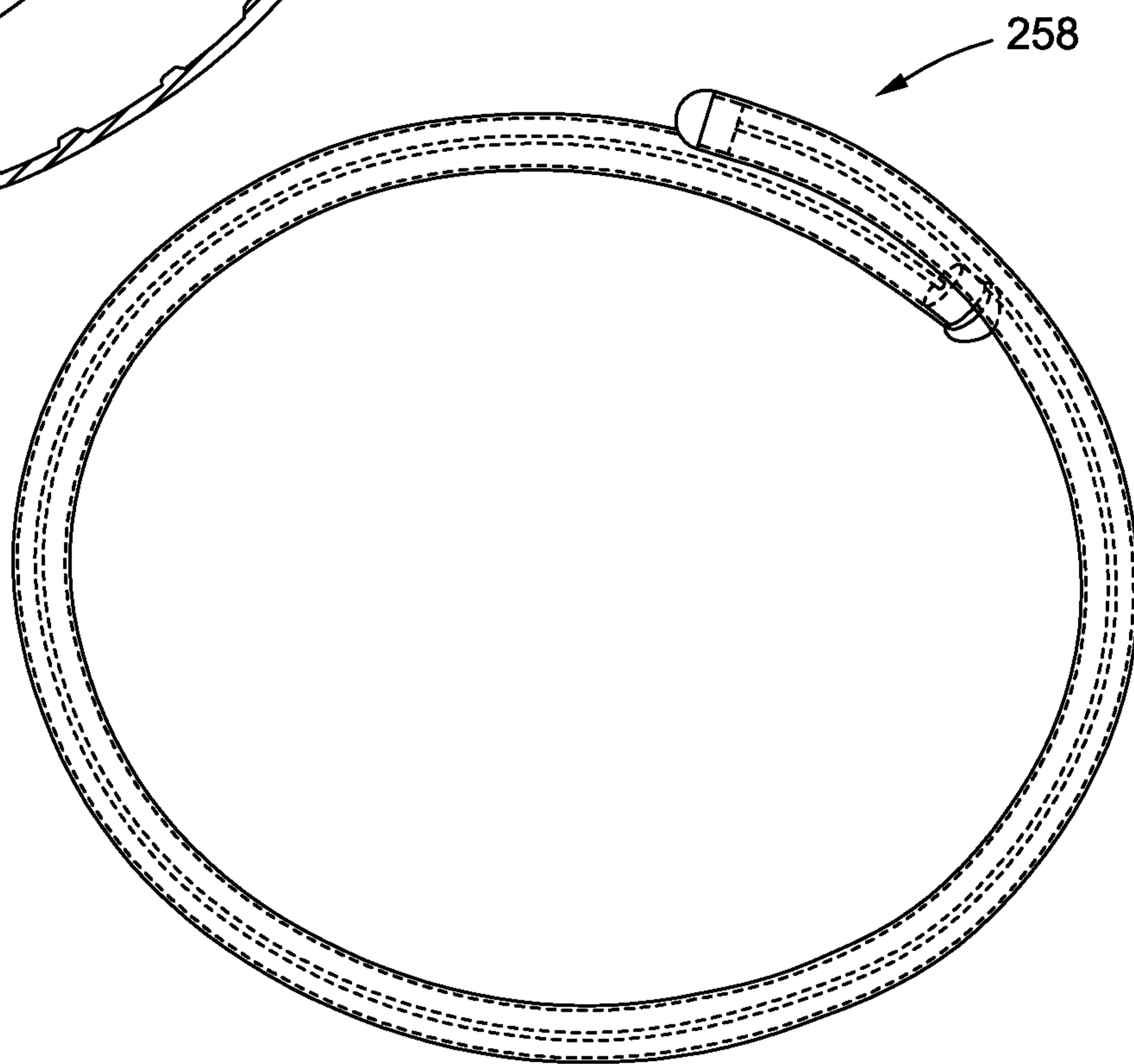

FIG. 7A

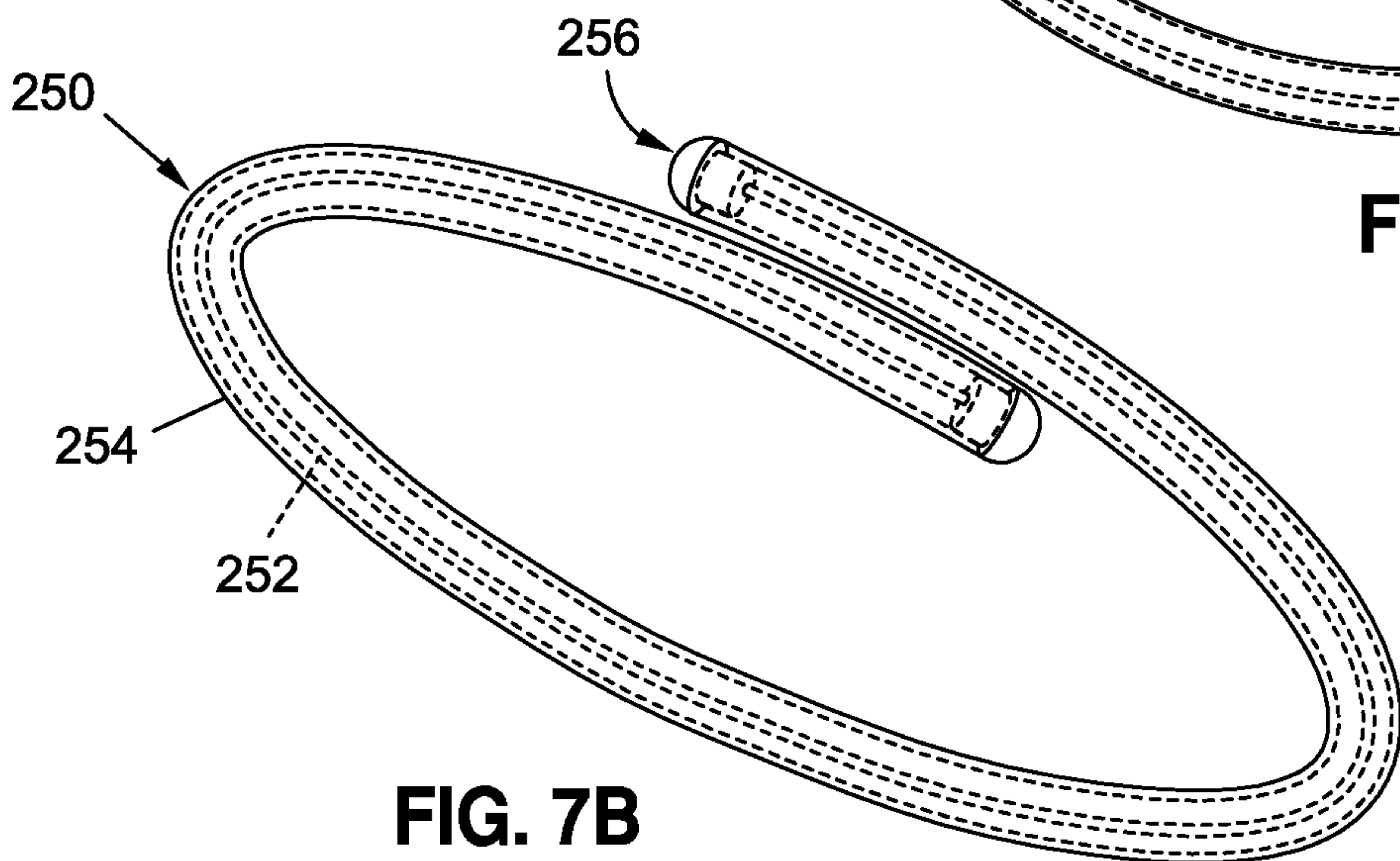

FIG. 7B

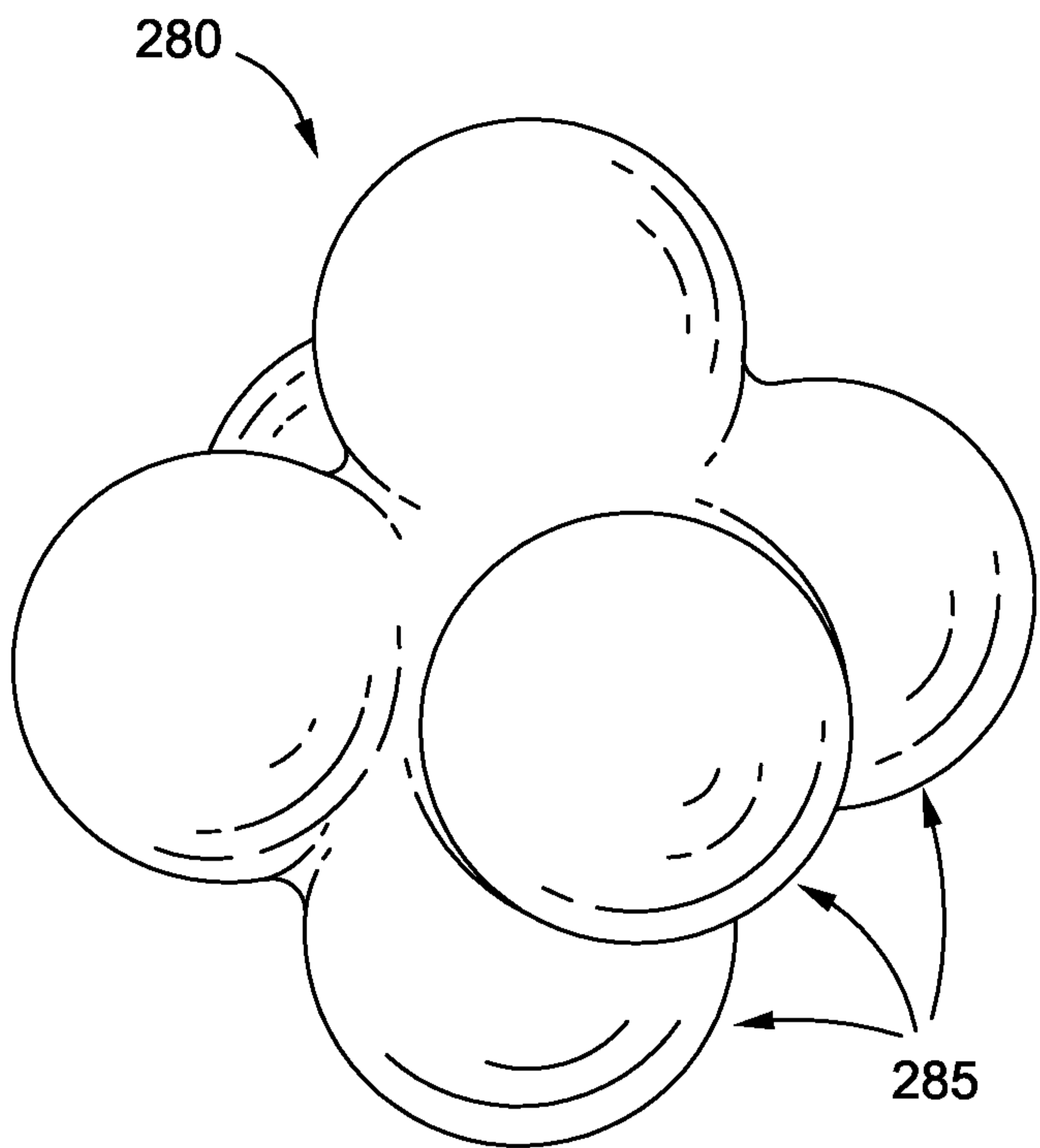

FIG. 8

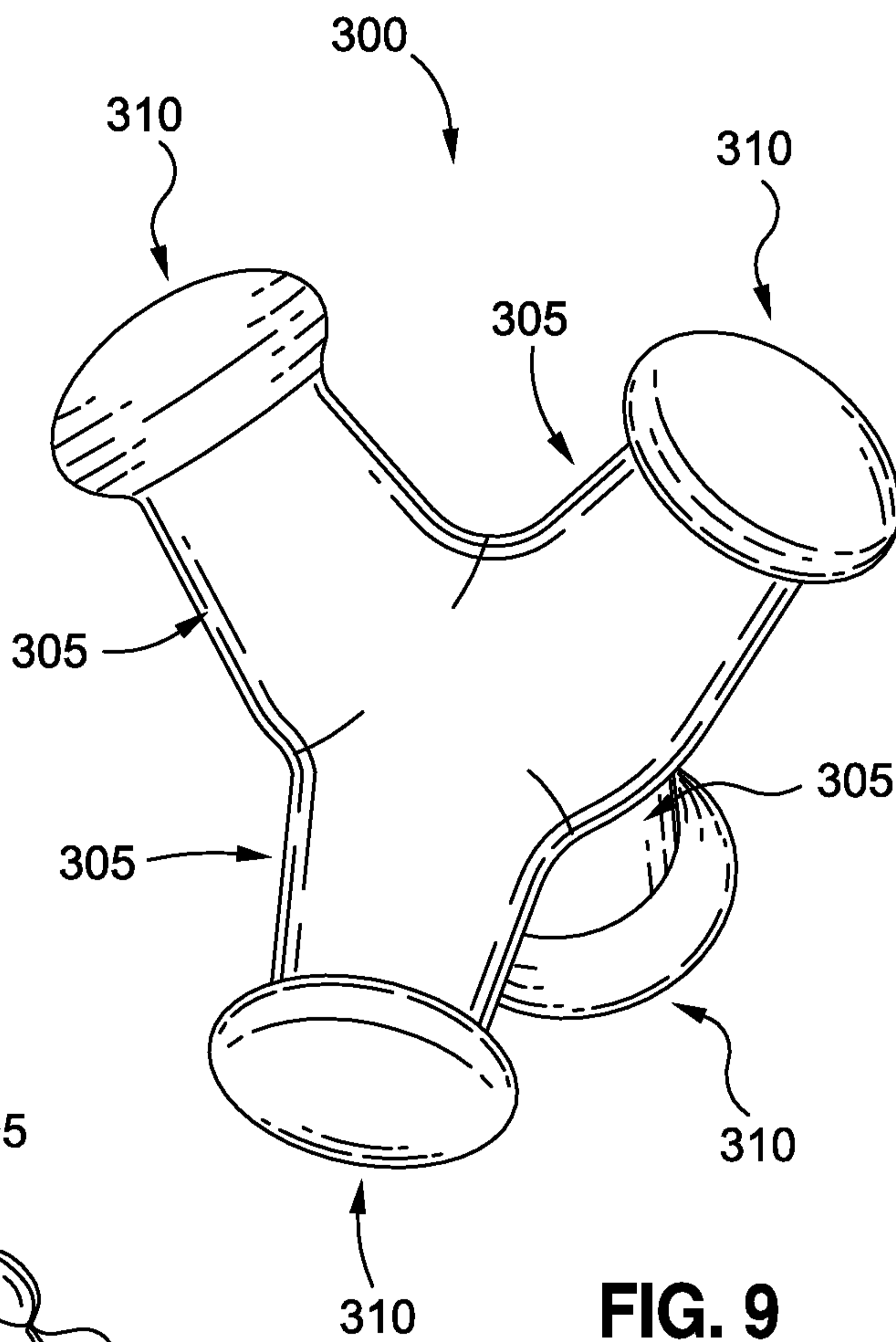

FIG. 9

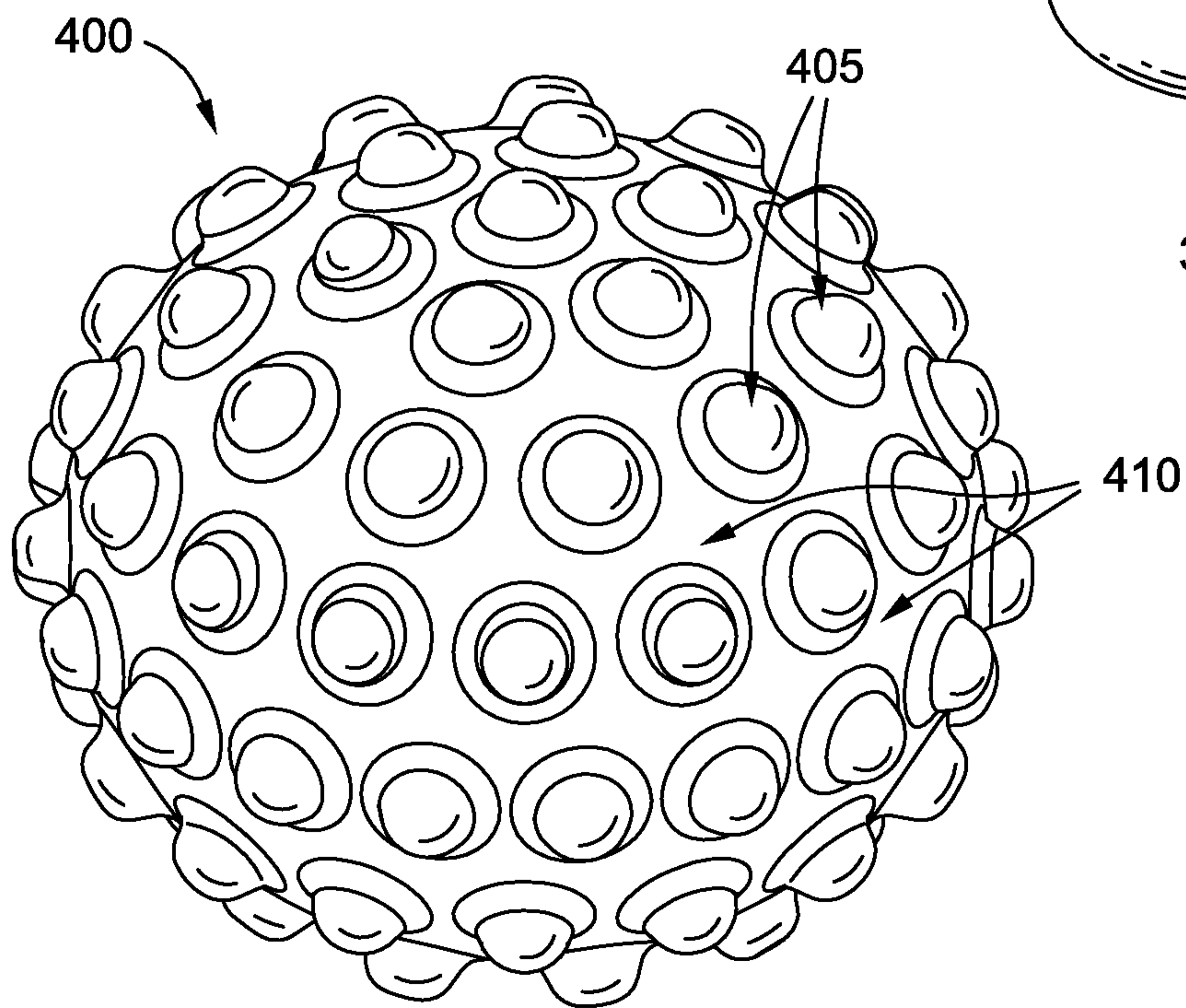

FIG. 10

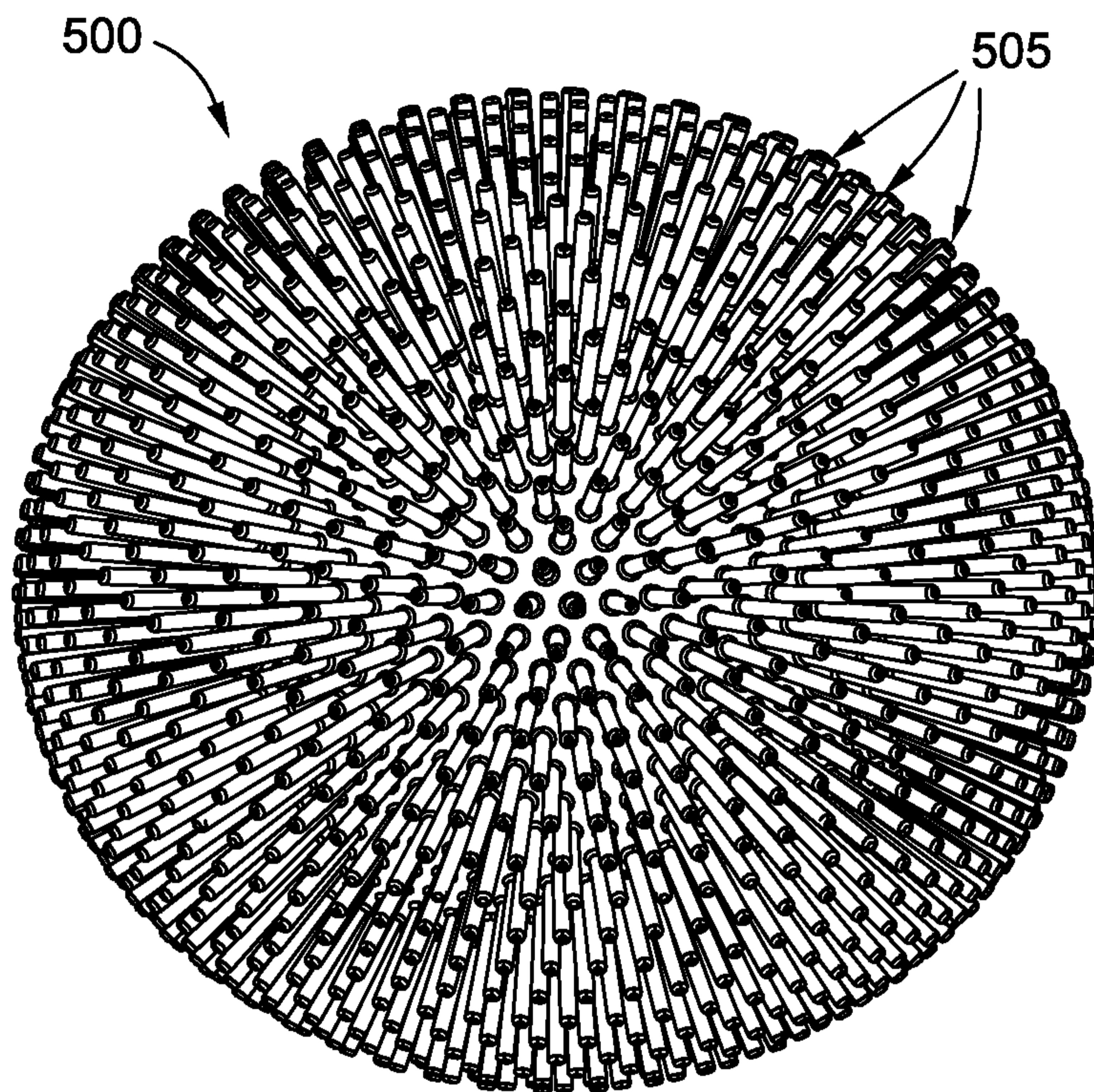

FIG. 11

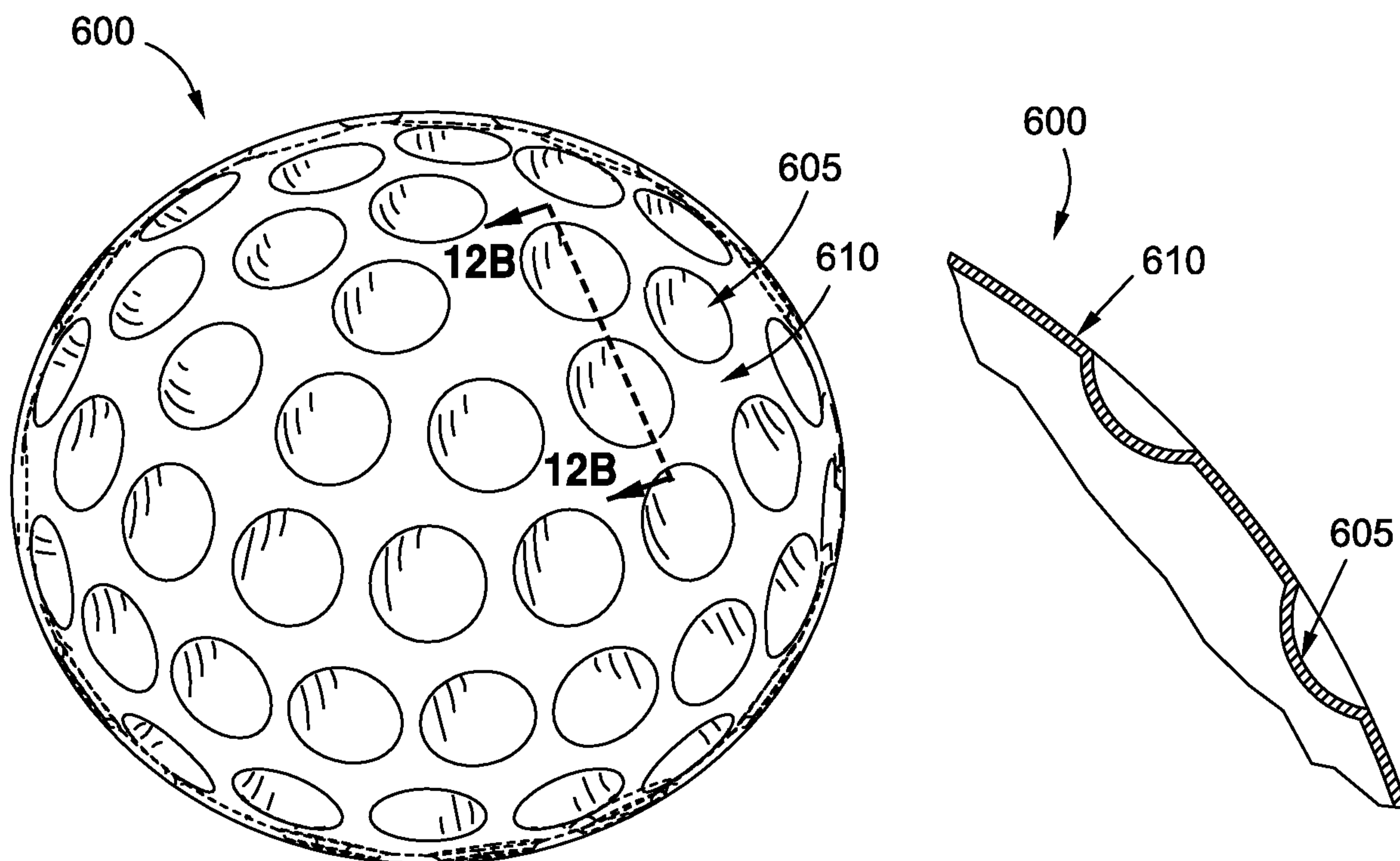

FIG. 12A

FIG. 12B

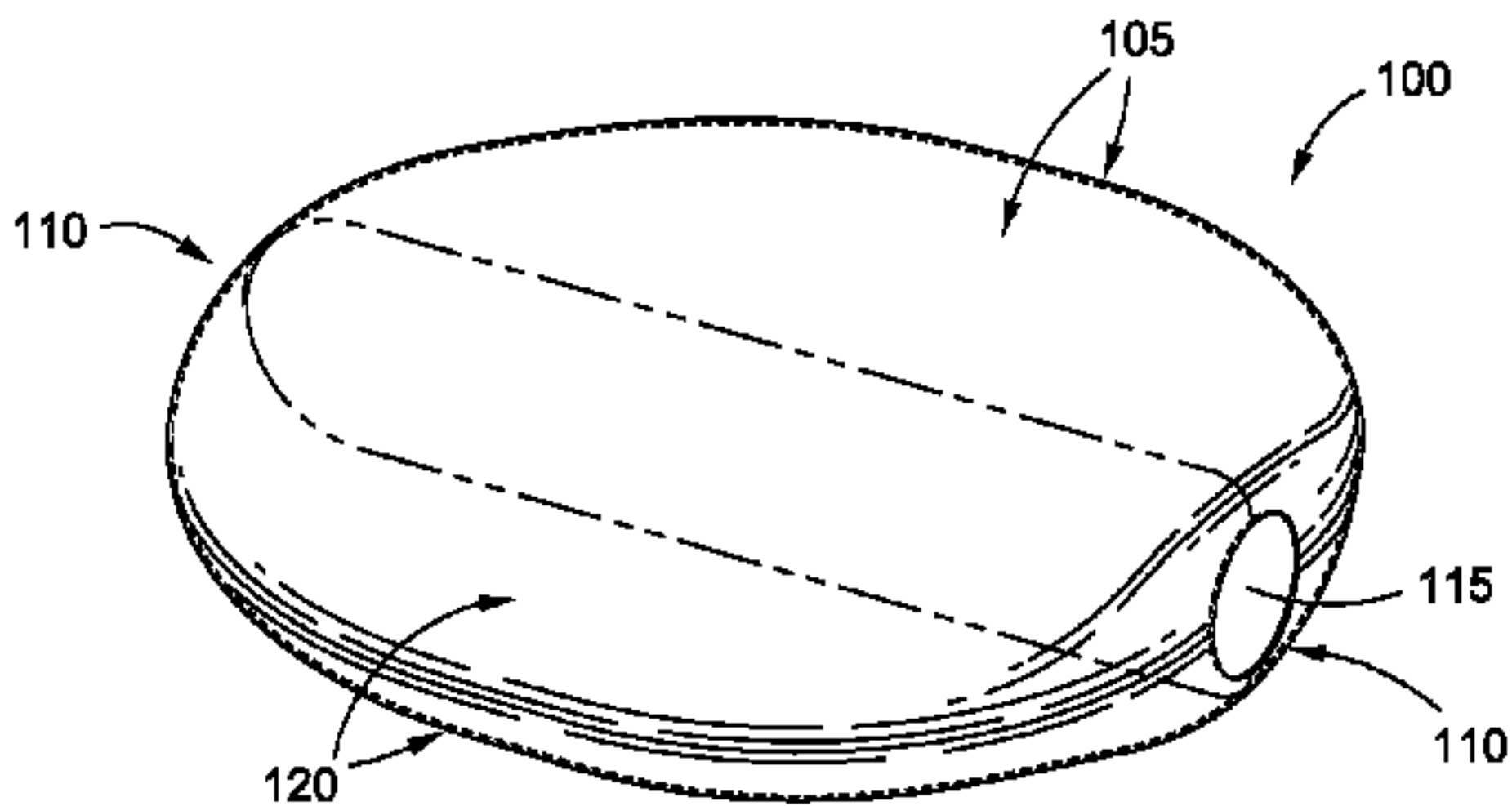

FIG. 1A

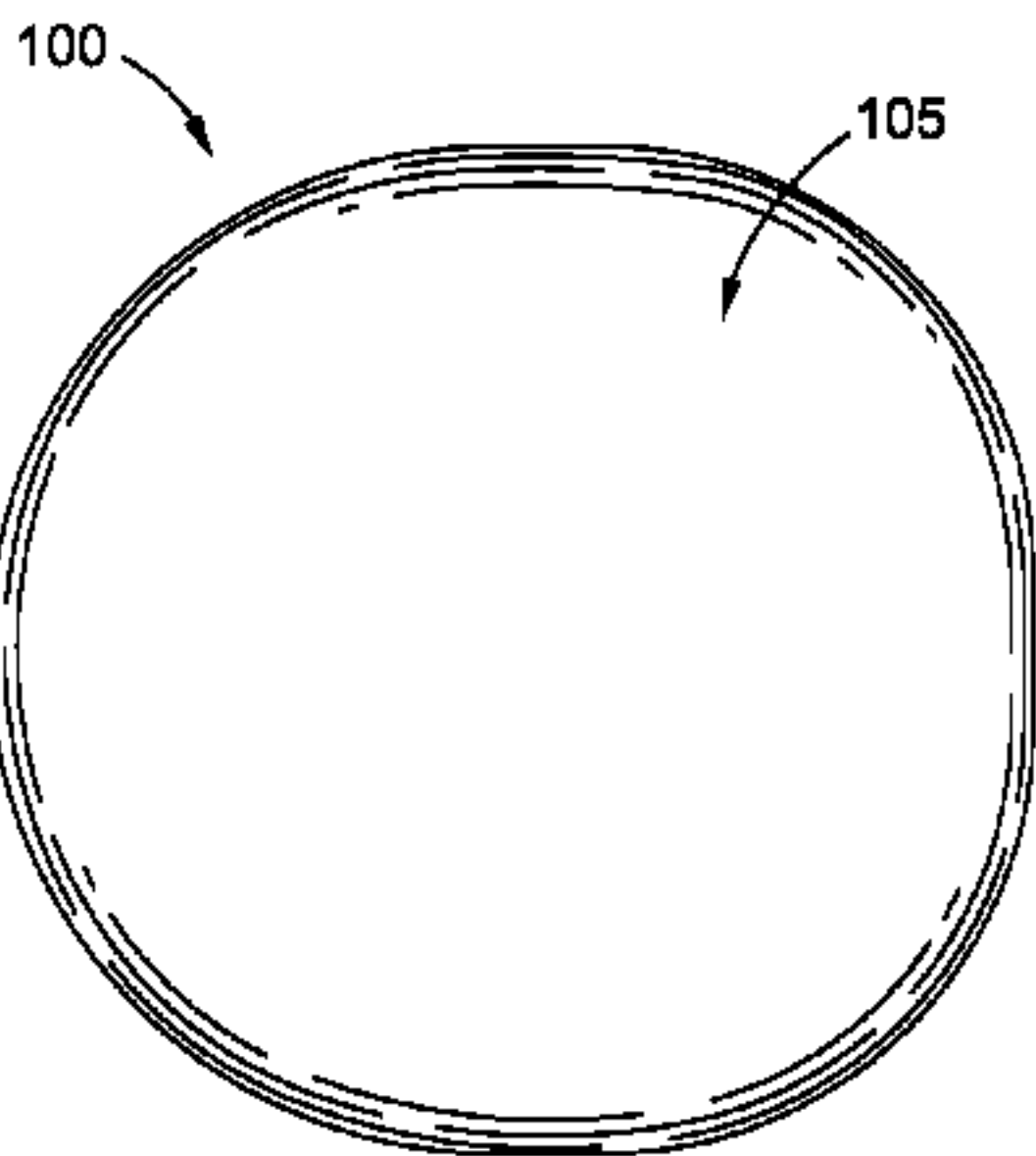

FIG. 1B

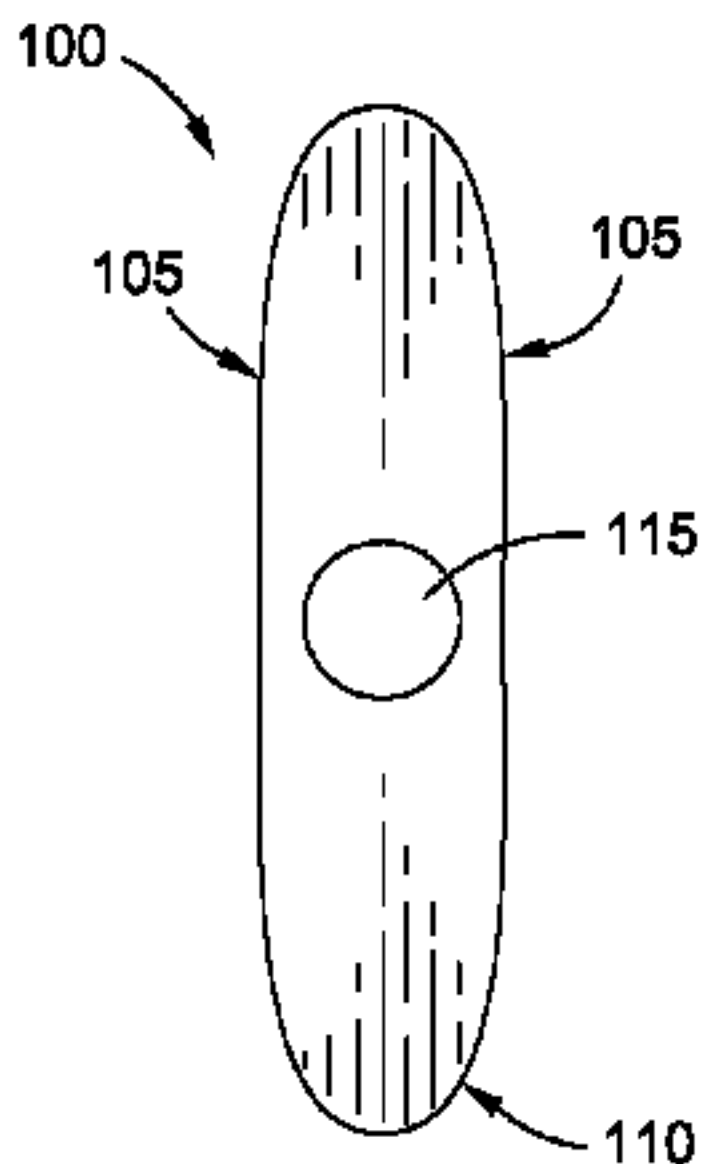

FIG. 1D

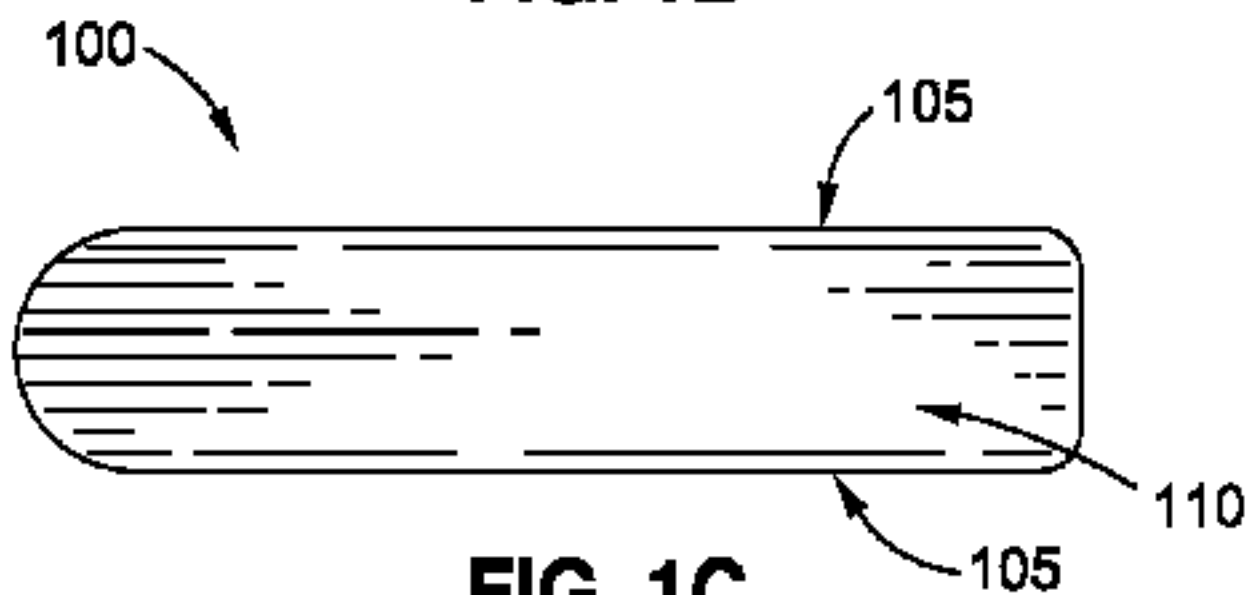

FIG. 1C