



(19) **United States**

(12) **Patent Application Publication**
Steger et al.

(10) **Pub. No.: US 2009/0259263 A1**

(43) **Pub. Date: Oct. 15, 2009**

(54) **APPARATUS AND METHODS OF FIXATING BONE**

Publication Classification

(75) Inventors: **Shon David Steger**, Warsaw, IN (US); **Robert Travis McKee**, Jacksonville, FL (US); **Shawn David Roman**, Orange Park, FL (US); **Bradley James Winterroth**, Jacksonville, FL (US)

(51) **Int. Cl.**
A61F 5/00 (2006.01)
A61B 17/08 (2006.01)
A61F 2/28 (2006.01)
(52) **U.S. Cl.** **606/86 R**; 606/151; 623/23.62

Correspondence Address:
ARENT FOX LLP
1050 CONNECTICUT AVENUE, N.W., SUITE 400
WASHINGTON, DC 20036 (US)

(57) **ABSTRACT**

Apparatus and methods of fixating bone include repairing or remodeling a hard tissue defect with a composite bone structure. The composite bone structure includes at least two hard tissues or bones and a scaffold material fixed together by an adhesive component. The apparatus and methods include positioning the hard tissues/bones, conforming the scaffold material to at least a portion of a surface of the hard tissues/bones, contacting the adhesive component with the hard tissues/bones and the scaffold material, and changing the material state of the adhesive component to another material state at which the adhesive component fixes together the hard tissues/bones and the scaffold material, thereby forming a composite bone structure having a desired rigidity.

(73) Assignee: **Biomet Microfixation, Inc.**, Jacksonville, FL (US)

(21) Appl. No.: **12/101,571**

(22) Filed: **Apr. 11, 2008**

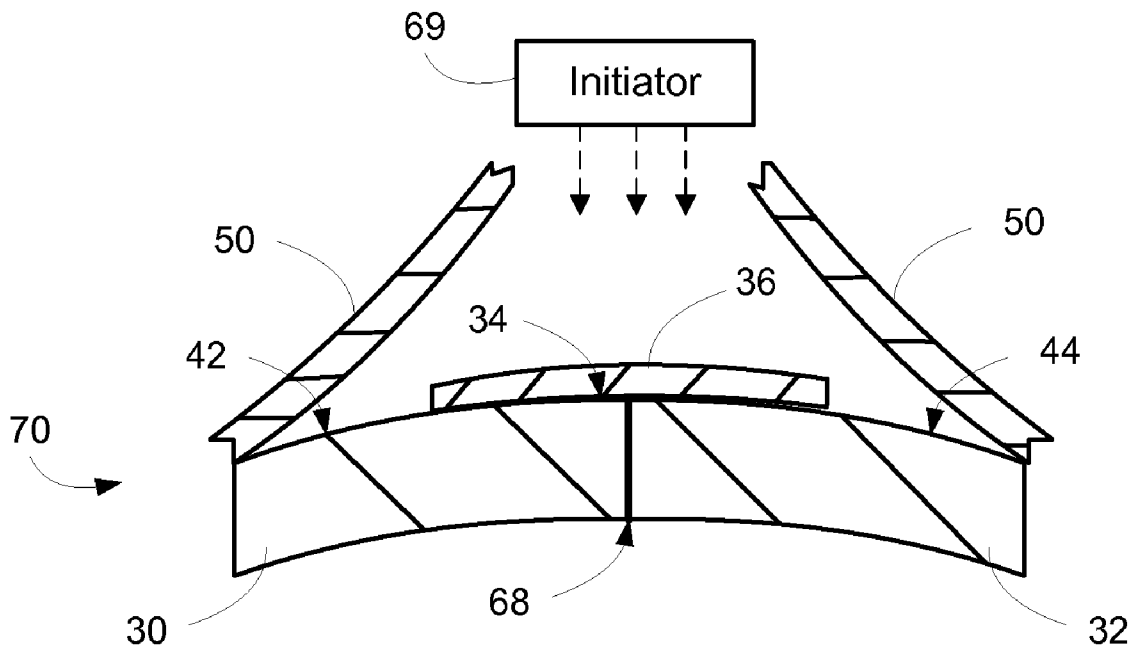

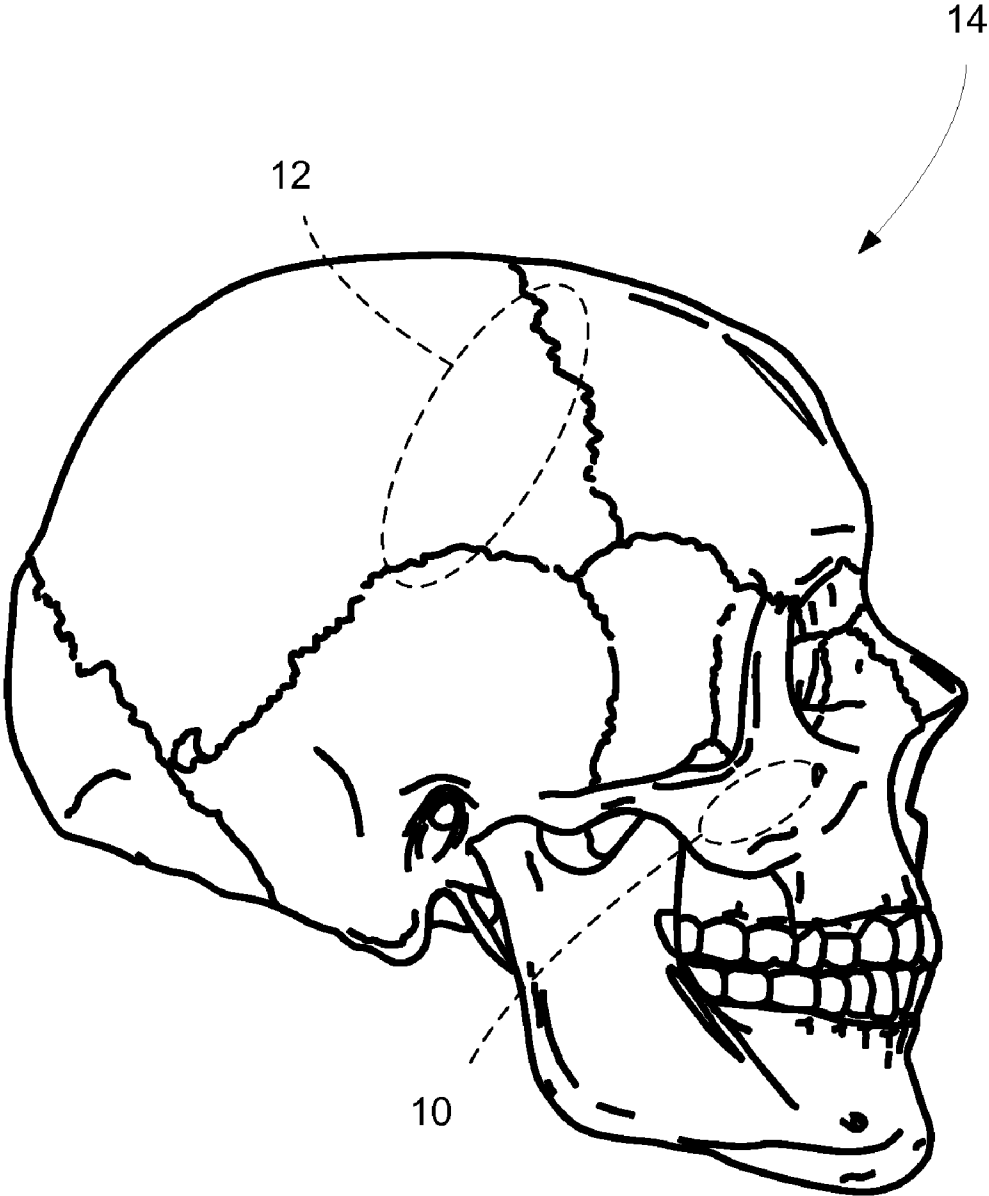

Fig. 1

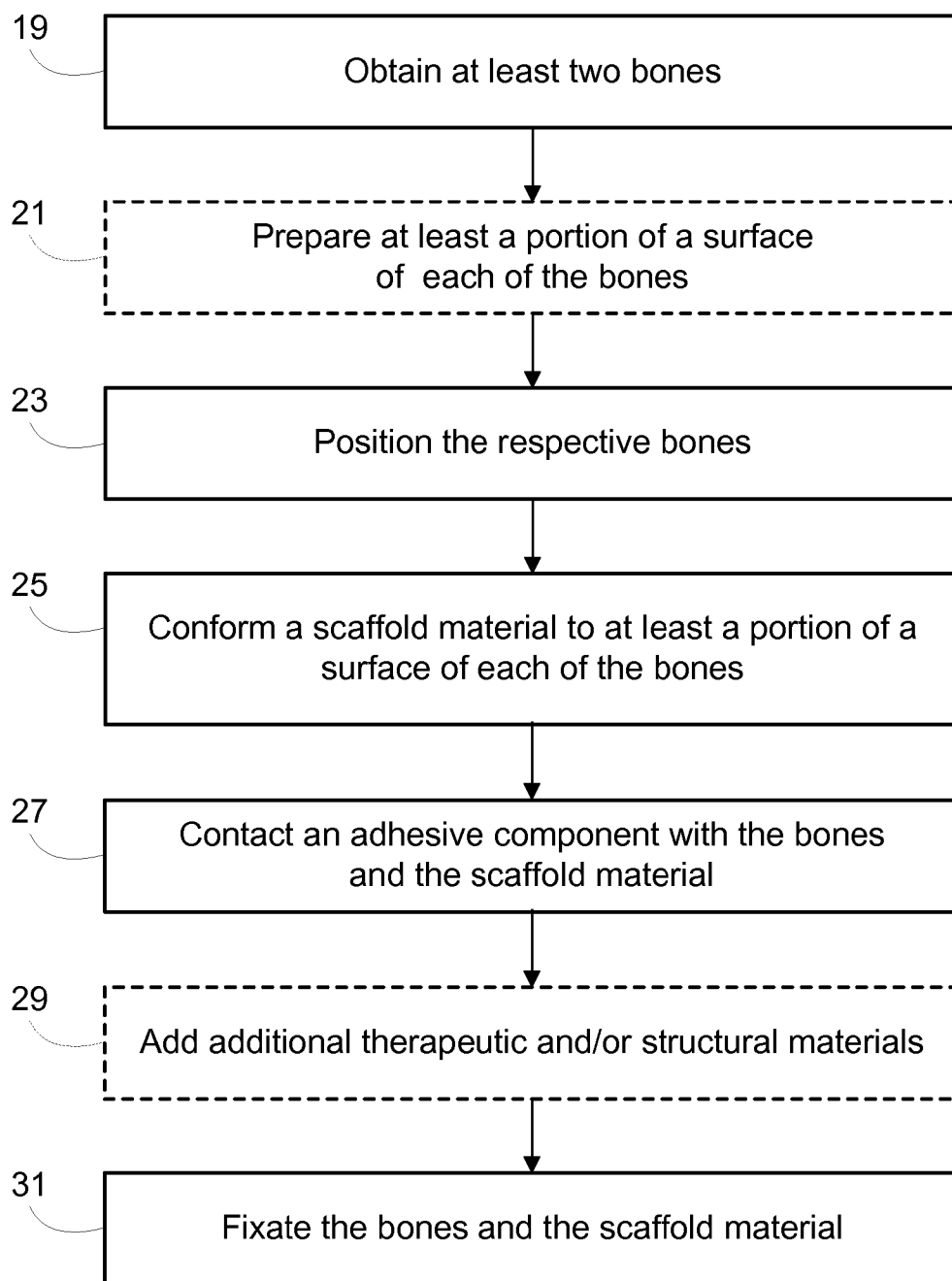

Fig. 2

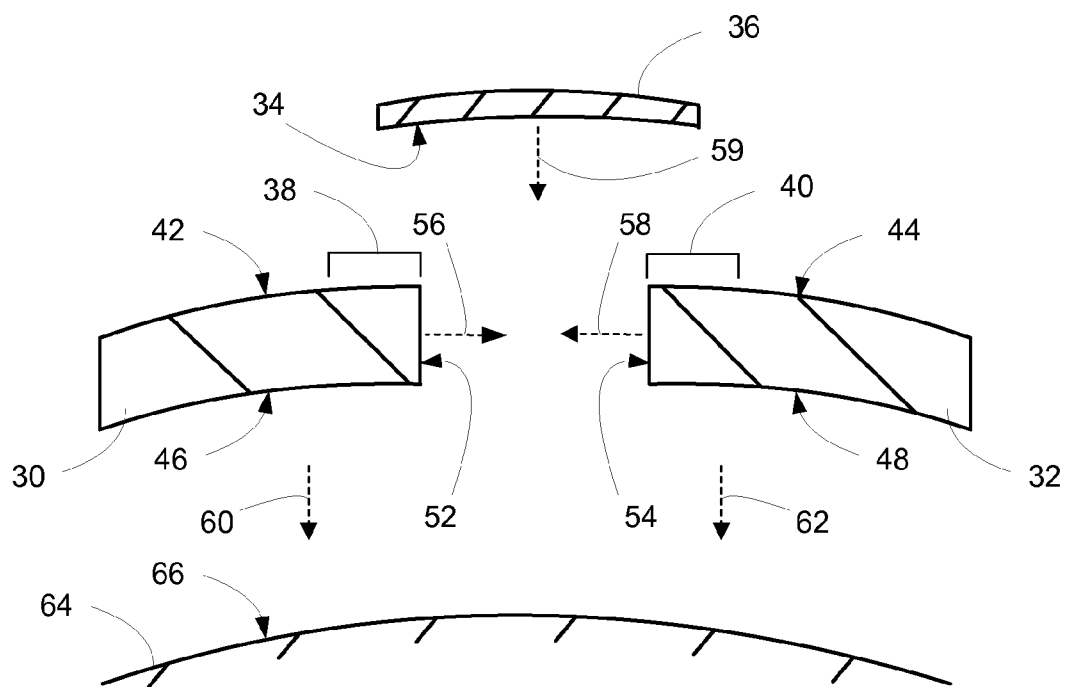

Fig. 3

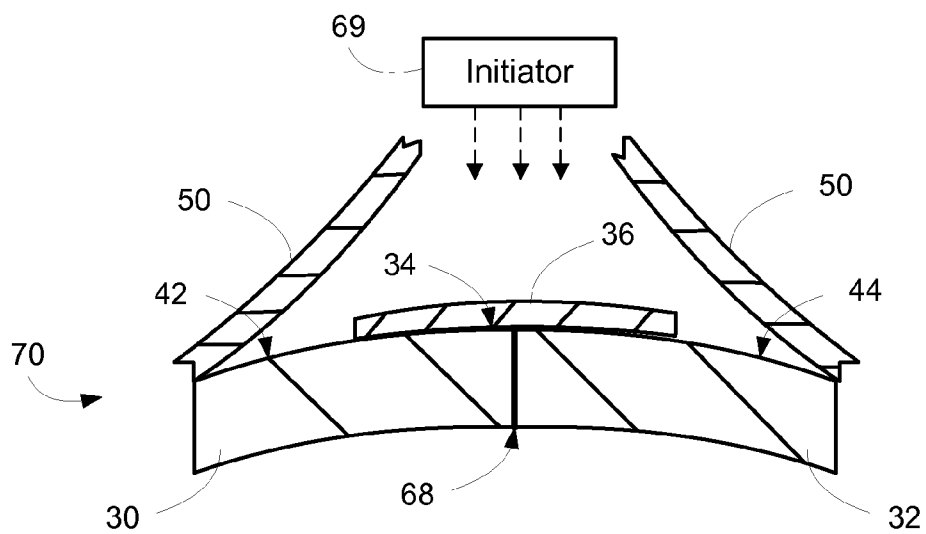

Fig. 4

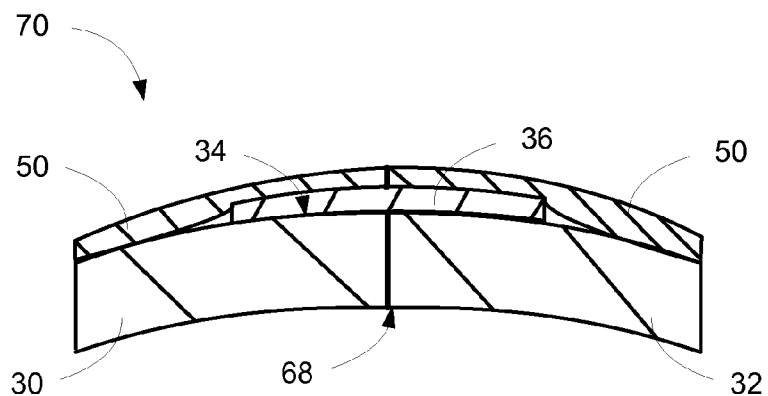

Fig. 5

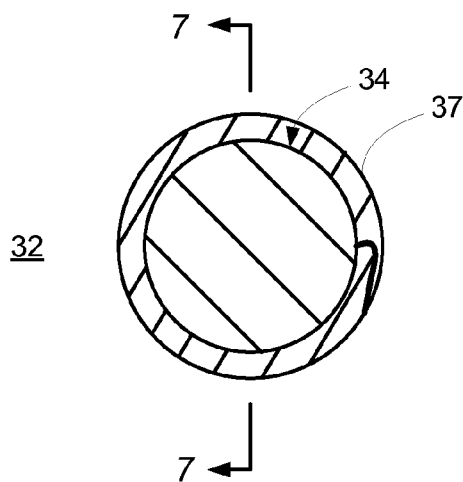

Fig. 6

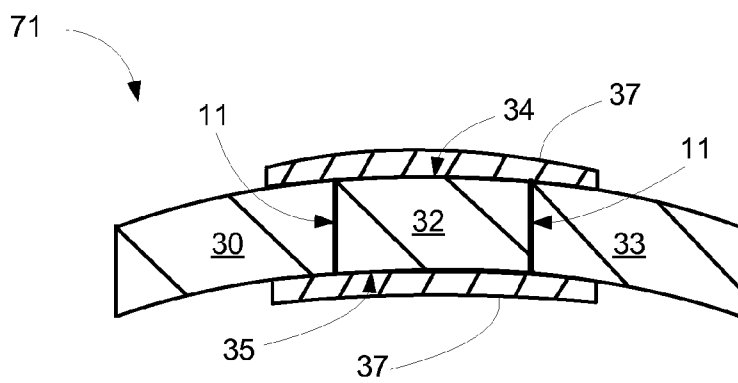

Fig. 7

APPARATUS AND METHODS OF FIXATING BONE

BACKGROUND

[0001] The present technology relates to apparatus and methods of treating or repairing hard tissue defects.

[0002] The treatment of a hard tissue defect, such as fractured or misshapen bone, involves a number of complex surgical procedures. More effective apparatus and methods are desired to enable such treatment, and to promote and enhance tissue repair in terms of clinical ease of use, cost, healing and efficacy.

SUMMARY

[0003] In some aspects, the present technology provides a method of fixating bone comprising connecting at least two bones and a scaffold material with an adhesive component such that the adhesive component is in contact with at least a portion of a surface of each of the bones and the scaffold material. The method further includes fixating the bones and the scaffold material to define a desired structure having a desired rigidity based on changing a material state of the adhesive component.

[0004] In another aspect, a method of craniomaxillofacial surgery comprises accessing at least two bones at least partially defining a hard tissue defect at a location within a body, wherein the location comprises a cranial location or a maxillofacial location. The method further includes positioning the bones into a desired relative orientation, conforming a scaffold material to at least a portion of a surface of each of the bones, and contacting an adhesive component between at least a portion of each of the bones and the scaffold material. Additionally, the method includes fixating the bones and the scaffold material in the desired relative orientation to remodel the hard tissue defect. The fixating is based on changing the adhesive component to a material state at which the adhesive component fastens together the bones and the scaffold material with a desired rigidity.

[0005] In a further aspect, a composite bone structure comprises a first bone having a first surface and at least one other bone, wherein each other bone comprises a respective second surface. The composite bone structure also includes a scaffold material positioned to connect the first bone and the at least one other bone, wherein the scaffold material is adaptable to conform to the first surface and each respective second surface. Additionally, the composite bone structure includes an adhesive component in contact with at least a portion of the first bone, each other bone and the scaffold material, wherein the adhesive component is changeable to a material state at which the adhesive component affixes the first bone, each other bone and the scaffold material to define a composite bone structure having a desired rigidity.

[0006] Further areas of applicability of the present teachings will become apparent from the detailed description provided herein. It should be understood that the detailed description and specific examples, while indicating various embodiments of the technology described below, are intended for purposes of illustration only and are not intended to limit the scope of the teachings.

BRIEF DESCRIPTION OF THE DRAWINGS

[0007] The present teachings will become more fully understood from the detailed description and the accompanying drawings, wherein:

[0008] FIG. 1 is a perspective view of representative sites of hard tissue defects subject to treatment or repair according to the technology described herein;

[0009] FIG. 2 is a diagrammatic representation of one aspect of a representative method of fixating bone to treat the hard tissue defect of FIG. 1;

[0010] FIG. 3 is an exploded, cross-sectional view of one aspect of representative components of a composite bone implant;

[0011] FIG. 4 is a cross-sectional view of the composite bone implant of FIG. 3 forming a desired structure;

[0012] FIG. 5 is a cross-sectional view of the composite bone implant of FIG. 3 in a final state;

[0013] FIG. 6 is a transverse cross-sectional view of another aspect of a composite bone structure; and

[0014] FIG. 7 is a cross-sectional view of the composite bone structure in plane 7-7 of FIG. 6.

DETAILED DESCRIPTION

[0015] The following description of technology is merely exemplary of the subject matter, manufacture and use of one or more inventions, and is not intended to limit the scope, application, or uses of any specific invention claimed in this application or in such other applications as may be filed claiming priority to this application, or patents issuing therefrom.

[0016] Referring to FIG. 1, the described apparatus and methods of fixating bone relate to therapies or treatments for a hard tissue defect, which includes fractured or misshapen or deficient bone in a body of a patient. The hard tissue defect may be located anywhere on the body, and will be discussed specifically in relation to a maxillofacial defect 10 or a cranial defect 12 on a skull 14 of a patient. For example, the apparatus and methods of fixating bone may include procedures such as, but not limited to: cranial or calvarial vault remodeling; maxillary complex fracture fixation procedures; comminuted bone procedures; cranial or neurosurgical flap procedures; craniostylosis procedures; infant craniofacial surgery; pediatric reconstructive procedures; pediatric mid-face and craniofacial trauma procedures; brow-lift procedures; bone-graft procedures in the mid-face, mandible or craniofacial skeleton; trauma and reconstructive procedures of the mid-face or craniofacial skeleton, including frontal, parietal, temporal, sphenoid and occipital bones; fixation of fractures of the maxilla, zygoma, zygomatic arch, orbital rim, frontal sinus wall, nasal, ethmoid and lacrimal bones; iliac crest graft cover; mandibular osteotomies; tumor reconstruction in the mid-face or craniofacial procedures; Lefort fractures (I,II, III); proximal tibia revisions; and generally any bone defect correction procedure. Additionally, as referred to herein, the term "hard tissue" relates to bone, skeletal or ossified tissue, which is relatively hard and rigid as compared to other bodily tissue such as skin.

General Method

[0017] Referring to FIG. 2, in one aspect, a method of fixating bone to provide therapy for or treatment of a hard tissue defect includes obtaining two or more bones (Block 19). For example, the bones may be obtained from the site of the hard tissue defect, as the treatment or therapy may involve remodeling the defect into a desired structure. Optionally, as indicated by dashed lines, the method may include preparing at least a portion of a surface of each of the bones (Block 21).

The surface preparation is provided to enhance an ability of the bone to be fixated. The method involves positioning the bones for fixation (Block 23) in a desired relative orientation to achieve a desired remodeled structure. Further, the method includes conforming a scaffold material, as defined below, to at least a portion of the surface of each of the bones (Block 25). For example, the scaffold material may be positioned in contact with the respective prepared surfaces. Moreover, the method includes contacting an adhesive component with and between each of the bones and the scaffold material (Block 27). The adhesive component or a portion of the adhesive component may be carried by the scaffold material, or may be added to the construct, or both. Optionally, as indicated by dashed lines, the method may include adding additional therapeutic or structural materials, or both, to the structure (Block 29). For example, bone growth-promoting materials may be added to promote bone fusion, or bone void fillers such as bone cement or bone-growth scaffold may be added to fill in gaps between the bones. Additionally, the method includes fixating the bones and the scaffold material (Block 31) to form a composite hard tissue or bone structure that defines at least a portion of the desired remodeled structure. The fixating includes changing a state of at least the adhesive component, and optionally of the scaffold material, to secure the bones and the scaffold material in the desired relative orientation. Each of the aforementioned actions will be more fully discussed below.

Obtain Bones

[0018] As discussed above, at least two bones are obtained (Block 19). For example, in one aspect, referring to FIGS. 1 and 3, the at least two bones 30 and 32 (FIG. 3) may be obtained from a surgical site or location, such as the site of hard tissue defect 10 or 12 (FIG. 1). Further, referring to FIGS. 6 and 7, for example, more than two bones 30, 32 and 33 may include bones associated with a hard tissue defect 11, such as a fracture or multiple fractures in a long bone, in a zygomatic arch, or in any other skeletal structure. Although discussed as being obtained from hard tissue defect 10 or 11 or 12, it should be further understood that in other aspects obtaining bones 30 and 32 (and/or 33) may include obtaining one or more bone segments from other bodily locations, obtaining one or more allograft bone segments, or any combination thereof. Further, although discussed in terms of the at least two bones 30 and 32, it should be understood that the described aspects are not limited thereto, but may include any number of bone segments. Moreover, the two or more bones 30 and 32 may include at least one portion of bone connected to a skeletal structure, or at least one separate bone segment, or both. Additionally, the at least two bones 30 and 32 include hard tissue, which as noted above comprises bone, skeletal and/or ossified tissue. For example, in some aspects, the at least two bones 30 and 32 may be fractured portions of bone, such as may result from local trauma. In other aspects, for example, the at least two bones 30 and 32 may be deformed portions of bone. Further, the term "bone" may include a bone, any part or segment of a bone, or any fragment of a bone.

[0019] Additionally, obtaining the at least two bones 30 and 32 may further include a surgical procedure including accessing a harvesting location in the body of the patient. For example, the surgical procedure may include making an incision through the skin and other soft tissue of the patient at the harvesting location to expose one or more of the at least two

bones 30 or 32. Further, obtaining the at least two bones 30 or 32 may include removing fractured portions of bone from the accessed location, repositioning fractured portions of bone within the accessed location, cutting the bone at the accessed location to define one or more of the at least two bones 30 or 32, or a combination of both. Alternatively or in addition, as noted above, obtaining the at least two bones 30 or 32 may further include obtaining one or more allograft bone segments.

Prepare Surfaces

[0020] Referring again to FIG. 2, the method optionally includes applying a surface preparation to at least a portion of a surface of the bones 30 and 32 (and, optionally, 33) (Block 21). Although the surface preparation (Block 21) is shown in FIG. 2 and discussed herein as occurring prior to the positioning of bones 30 and 32 (Block 23), the surface preparation may be applied at any time before, during or after the positioning. Referring to FIGS. 3, 6 and 7, the surface preparation may include any surface treatment effective to increase an ability of adhesive component 34 to secure scaffolding material 36 or 37 to the respective bones 30 and 32 (and 33), to improve fusion with an adjacent bone segment, to shape the respective bones 30 or 32 (or 33) into a desired form, or any combination thereof. It should be noted that the surface treatment may be applied to any surface used to connect together one or more bones or a bone and the scaffold material.

[0021] Referring specifically to FIG. 3, in one aspect, the surface preparation may be applied to at least a respective portion, such as portions 38 and 40, of a respective external or top surface 42 and 44 of the respective bones 30 and 32. It should be noted, however, that internal or bottom surfaces, and/or side surfaces may likewise be treated depending on the particular circumstance or preference of the user. In one aspect, the respective portion 38 and 40 substantially corresponds to an area in which scaffolding material 36 will be placed. The surface preparation may include roughening the top or external-facing surface 42 and 44. In this respect, the top or external-facing surface 42 and 44 faces away from the body of the patient, and opposed to a respective bottom or internal-facing surface 46 and 48. For example, such surface roughening may comprise mechanically abrading the respective bone surfaces, such as with a surgical tool having an abrading element, or may comprise removal of a portion of the surface, such as with a surgical tool having a cutting element. Alternatively, or in addition, the surface preparation may be applied to respective side surfaces 52 and 54, defined between each respective top or external-facing surface 42 and 44 and each respective bottom or internal-facing surface 46 and 48, to improve an ability of the respective side surfaces 52 and 54 to fuse to one another or alter the bonding interface with the adhesive component 34.

[0022] Referring to FIG. 4, additionally or alternatively, in other aspects, the surface preparation may include temporarily or permanently removing or peeling back a periosteum layer 50 from the respective portions 38 and 40 of the respective top or external-facing surfaces 42 and 44 of the bones 30 and 32. Further, the surface preparation may include reshaping one or more of bones 30 and 32 to obtain a desired remodeled structure to treat hard tissue defect 10 or 12. Alternatively, or in addition, the surface preparation may further include drying the respective portions 38 and 40 of the surfaces of bones 30 and 32 to enable improved contact with scaffold material 36 and/or adhesive component 34. In yet

other aspects, the surface preparation may include applying a chemical to perform one or more actions, such as removing the periosteum layer 50, roughening at least a portion of respective surfaces of bones 30 and 32, reforming the shape of one or more bones 30 and 32, drying the surface, removing a selected material from the surface, such as a lipid, or any combination thereof.

Position Bone Segments

[0023] Referring again to FIG. 2, the bones 30 and 32 (and, optionally, 33) are placed in a desired relative position (Block 23). Although the relative positioning of the bones is shown in FIG. 2 and discussed herein as occurring prior to the conforming of the scaffold material (Block 25) and the contacting of the adhesive component (Block 27), the relative positioning may occur once or may occur multiple times before or after other steps of the described methods. In one aspect, for example referring to FIGS. 3 and 4, respective side surfaces 52 and 54 are positioned opposing one another and are moved into a desired orientation adjacent to one another. In particular, as noted by arrows 56 and 58 (FIG. 3), the at least two bones 30 and 32 are moved toward one another until a desired orientation (FIG. 4) of bones 30 and 32 and/or side surfaces 52 and 54 is achieved. In another aspect, for example, the desired orientation may include a position wherein at least portions, and preferably a majority, of respective side surfaces 52 and 54 are contiguous or are in contact with one another so as to enable bone growth between the respective side surfaces 52 and 54. However, gaps may exist or may be desirable between the at least two bones 30 and 32. In some aspects, for example, such gaps may be filled with a bone void filler, such as a bone cement or a bone-growth scaffold.

[0024] Further, for example, the desired orientation (FIG. 4) may include the respective top surfaces 42 and 44 having a desired form, such as an arc, a plane, an orientation, or a combination thereof. Further, for example, the desired orientation may correspond to a desired remodeled structure to treat hard tissue defect 10 or 12. It should be noted that the positioning of the at least two bones 30 and 32 may include positioning in situ, in vitro, or a combination thereof. Additionally, for example referring to FIG. 7, the desired orientation may remodel the long bone, zygomatic arch, or multiple fracture defect into a shape that approximates a non-defective skeletal structure.

[0025] In an optional aspect, referring to FIG. 3, as indicated by arrows 60 and 62, the positioning of bones 30 and 32 may include positioning against a mold 64 having a mold surface 66 with a desired shape. For example, the desired shape corresponds to a desired orientation of bones 30 and 32, or a desired remodeled structure to treat hard tissue defect 10 or 12. Although illustrated as positioning bottom or internal-facing surfaces 46 and 48 of bones 30 and 32 against mold surface 66, it should be understood that the optional positioning against mold 64 may alternatively include positioning top or external-facing surfaces 42 and 44 against mold surface 66.

Conform Scaffold

[0026] Referring back to FIG. 2, the method further includes conforming the scaffold material, which in some optional aspects may include the adhesive component, to at least a portion of the surface of each of the bones (Block 25). In one aspect, for example referring to FIGS. 3 and 4, scaffold material 36 is moved in direction 59 and placed across an

interface or gap 68 (FIG. 4) between the opposing side surfaces 52 and 54 of bones 30 and 32. In particular, in one aspect, at least a part of scaffold material 36 is placed into contact with the opposing prepared surface portions 38 and 40 of bones 30 and 32, thereby bridging interface 68. Although illustrated as a plane, it should be noted that interface 68 may comprise any shape or combination of shapes. Further, for example, scaffold material 36 is positioned such that at least a portion of adhesive component 34 connects between scaffold material 36 and the opposing prepared surface portions 38 and 40 of bones 30 and 32. As such, scaffold material 36, which may include or carry adhesive component 34, is positioned in a manner to allow for securing bones 30 and 32 (and, optionally, 33 in FIG. 7) in a desired relative orientation, and to further bridge interface 68 (or defect 11 in FIG. 7) to promote bony fusion between the adjacent bone segments.

[0027] In another aspect, referring to FIGS. 6 and 7, scaffold material 37 may be wrapped around hard tissue defect 11, thereby fully enveloping the defective skeletal structure. In this aspect, the wrapping of the scaffold material 37 and subsequent fixation provides support to the structure in multiple directions.

[0028] Scaffold material 36 (or 37) may comprise any material capable of carrying adhesive component 34. For example, scaffold material 36 (or 37) may include, but is not limited to, materials such as a woven fabric, a mesh, a foam, a plate, a perforated membrane, a sheet, a porous structure, a PolyLactide weave or any combination thereof. Further, for example, scaffold material 36 (or 37) may have a surface that includes voids, peaks and valleys, ridges, grooves, channels, any combination thereof, or any other irregular surface that improves an ability of adhesive component 34 to bond or interdigitate with scaffold material 36 (or 37). Further, for example, scaffold material 36 (or 37) may be pre-impregnated with a desired or an effective amount of adhesive component 34, or all or some portion of the desired or effective amount of adhesive component 34 may be added to scaffold material 36 (or 37) at any time during the procedure described herein. For example, the desired or effective amount of adhesive component may comprise an amount effective to enable binding between scaffold material 36 (or 37) and at least respective portions 38 and 40 of respective bones 30 and 32, or to provide a desired rigidity or stiffness to the resulting structure, or both. Additionally, scaffold material 36 (or 37) may be sized so that the combination of bone segments 30 and 32 and scaffold material 36 (or 37) define a desired remodeled structure.

[0029] Further, scaffold material 36 (or 37) comprises a biocompatible material. In some aspects, scaffold material 36 (or 37) further comprises a bioresorbable material. For example, scaffold material 36 (or 37) may comprise a polymer, a resorbable polymer, a urethane, a polyurethane, a metal, a biocompatible material, a calcium salt material, a tissue, collagen, cellulose or combinations thereof. In one example, which is not to be construed as limiting, scaffold material 36 (or 37) may comprise a LACTOSORB plate available from Biomet, Inc. of Warsaw, Ind.

Contact the Adhesive with Bones And Scaffold

[0030] Referring back to FIG. 2, the method further includes contacting the adhesive component between the bones and the scaffold material (Block 27). As previously noted, adhesive component 34 may be carried by scaffold material 36 or 37, or may be separately added, or both. In one aspect, for example, scaffold material 36 or 37 includes adhe-

sive component **34** on a surface facing the bones **30** and **32** (and, optionally, **33**), thereby connecting the bones and the scaffold material when the scaffold material is adapted to conform to at least a portion of the respective surfaces of the bones.

[0031] Additionally, adhesive component **34** may comprise any material capable of forming a bond between scaffold material **36** or **37** and bones **30** and **32** (and, optionally, **33**), whether by chemical bonding, interdigitation or another method or combination of methods used to form a mechanical bond between the scaffold material and bone segments. Further, adhesive component **34** comprises a biocompatible material. In some aspects, adhesive component **34** further comprises a bioresorbable material. For example, adhesive component **34** may comprise a material such as a polymer, a urethane, a polyurethane, an amino acid containing polymer, an acrylic, a cyanoacrylate, a polymethyl methacrylate (PMMA), an alkylene bis(oligolactoyl)methacrylate, a fibrin-based material, a bone welding material, or combinations thereof.

[0032] In one example, which is not to be construed as limiting, adhesive component **34** may comprise a synthetic polymer, such as a biodegradable, polyester urethane/urea composition. For example, adhesive component **34** may comprise a combination of pre-polymers operable to react to form a cross-linked polymer network. For example, the combination of pre-polymers may include a first pre-polymer having isocyanate groups, such as from the combination of lysine di-isocyanate and pentaerythritol, and a second pre-polymer comprising a multi-branched polyol, such as poly(lactic acid) polyol (PLA), polyglycolic acid (PGA), caprolactone, etc. For example, the biodegradable, polyester urethane/urea composition may comprise one of the NOVOSORB materials available from PolyNovo Biomaterials Pty. Ltd. of Australia.

[0033] Additionally, in some aspects, adhesive component **34** comprises a plurality of states, including an initial unpolymerized or minimally polymerized state prior to and upon positioning of scaffolding material **36** (or **37**) and bones **30** and **32** (and **33**), then a fully polymerized or cured state after such positioning, for example, after exposure to an initiator **69** such as an additional chemical component, a light or radiation wave, etc., as will be discussed below in more detail.

[0034] Additionally, in some aspects, scaffold material **36** (or **37**) and adhesive component **34** may be formed from substantially the same material. Alternatively or in addition, in some aspects where both are bioresorbable, scaffold material **36** (or **37**) and adhesive component **34** may be formed from materials having substantially the same rate of resorption, which may provide a therapeutic benefit with respect to uniform degradation of the fixated structure, avoiding inflammation, or providing improved healing.

Add Additional Materials

[0035] Referring to FIG. 2, the method may optionally include adding additional therapeutic or structural materials, or both, to the structure (Block 29). For example, bone growth-promoting materials may be added to promote bone fusion. Further, for example, void fillers such as bone cement or bone-growth scaffold may be added to fill gaps between the bones. Additionally, other therapeutic agents such as gene therapy agents, infection-avoidance agents, pain-relieving agents, etc., may be added.

Fixate Bone Segments

[0036] As discussed above, and referring again to FIGS. 2, 4 and 7, once the bone segments and scaffold material are

positioned as desired and contacted with the adhesive component, the bones and scaffold material are fixated relative to one another to form a composite bone structure (Block 31). In one aspect, for example, fixating bones **30** and **32** (or **30**, **32** and **33**) is based on changing at least adhesive component **34** from a first material state to a second material state. At the first material state, adhesive component **34** may comprise a relatively flexible state. For example, in some aspects, the first material state may be a liquid state, a semi-solid state, or a non-rigid solid state. In some aspects, for example, the first material state has a viscosity sufficient to enable adhesive component **34** to be controllably positioned. For example, adhesive component **34** may be controllably positioned by having a viscosity and adhesion characteristic that allows adhesive component **34** to be controllably maintained on a desired surface, such as on a respective bone surface or on scaffold material, or both, to allow a user to avoid contacting the adhesive component with non-desired contact areas, such as areas within a surgical site other than the prepared surfaces of the bones or other than within scaffold material, or both. In any case, at the first material state, adhesive component **34** comprises sufficient flexibility to enable contact with bones and scaffold material. At the second material state, adhesive component **34** is operable to bind to scaffold material **36** as well as to two or more bones **30** and **32** (or **30**, **32** and **33**). Further, at the second material state, adhesive component **34** forms a structure having a desired rigidity or stiffness. The desired rigidity or stiffness may include, but is not limited to, a range of rigidities or stiffnesses substantially corresponding to the range of rigidities of hard tissue, such as the particular hard tissue comprising one or more of bones **30** and **32** (or **30**, **32** and **33**). In any case, at the second material state, adhesive component **34** comprises sufficient rigidity or stiffness to resist movement of the bones and scaffold material from the desired shape or orientation. For example, the amount of such resistance may be based on typical skeletal loads at the given defect location, or on the typical strength of bones in the defect location, or both. Thus, referring to FIGS. 4, 5 and 7, adhesive component **34**, which may be carried by scaffolding material **36** or **37**, changes into a state to secure scaffold material **36** (or **37**) and two or more bones **30** and **32** (or **30**, **32** and **33**) at a desired orientation, thereby forming a composite bone structure **70** (FIG. 5) or **71** (FIG. 7) having a desired shape or form to treat or remodel hard tissue defect **10** or **12** (FIG. 1) or **11** (FIG. 7).

[0037] Optionally, in some aspects, the fixating may further include changing the state of scaffold material **36** (or **37**) from a first state having substantial flexibility to a second state having substantial rigidity or stiffness. For example, the substantial flexibility comprises an amount of flexibility that allows scaffold material **36** or **37** to conform to a surface of the two or more bones **30** and **32** (or **30**, **32** and **33**). Further, for example, the substantial rigidity may include an amount of rigidity or stiffness at the second state greater than the amount that existed at the first state, which may include an amount of rigidity or stiffness to resist movement of the bones and the scaffold material out of the desired shape or form.

[0038] In particular, referring specifically to FIG. 4, in aspects in which adhesive component **34**, and optionally scaffold material **36** (or **37**), comprises a polymer, the changing of states of adhesive component **34** involves application of an initiator **69** operable to change at least adhesive component **34** to a second polymer state different from a first polymer state, wherein the second polymer state comprises a cured

state or a partially-cured or partial polymerization state. For example, depending on the specific procedure, it may be desirable to fully cure adhesive component **34** at one time, hence fully setting the form and structure of the resulting composite bone structure **70** (or **71**; FIG. 7). In other aspects, for example, it may be desirable to only partially cure adhesive component **34**, allowing for later manipulation of the form or structure of composite bone structure **70** or **71**. For example, the partial polymerization state is some state achieving less than substantially all of the mechanical strength of the adhesive, where mechanical strength may include one or more of bonding strength, rigidity, or stiffness. In such a case, once composite bone structure **70** or **71** has been completely positioned, then the method may include changing from the second state of partial polymerization to a third state of substantially full polymerization or full cure, thereby securing the relative orientation of composite bone structure **70** or **71**.

[0039] As noted above, the state changes may be effected by initiator **69**. Initiator **69** may include, but is not limited to, a radiation-based initiator, of which a light based initiator would be one example, a temperature change-based initiator, a chemical-based initiator, or any combination thereof or any combination of different types of each one. For example, adhesive component **34** may comprise a multi-part adhesive having at least two parts, wherein combination of a second part with the first part initiates a chemical reaction operable to change adhesive component **34** from the first relatively flexible state to the second relatively rigid state. One example of such a multi-part adhesive component **34** includes, but is not limited to, a biodegradable, polyester urethane/urea composition such as one of the NOVOSORB materials available from PolyNovo Biomaterials Pty. Ltd. of Australia. In another example, the radiation-based, or more specifically the light-based, initiator may comprise exposure to one or more light waves or radiation waves having a desired wavelength or range/band or ranges/bands of desired wavelengths to effect curing of the adhesive component. For instance, with adhesive component **34** comprising a urethane-based polymer, the initiator **69** may comprise ambient light, which includes as a component light of the wavelength of interest and which may slowly cure the adhesive component. However, a light of greater intensity and, specifically, with a greater intensity at a specific wavelength or band of wavelengths may be used to accelerate the light based curing process.

[0040] As noted above, the application of initiator **69** may differ throughout the fixation process, such as in the case where a partial fixation is achieved prior to a final fixation. For example, in the case of adhesive component **34** comprising a polymer, the method of causing polymerization up to a partial polymerization state may further include exposing adhesive component **34** to a first radiation at a first set of one or more wavelengths for a first time period operable to achieve less than substantially all of the mechanical strength of adhesive component. In this aspect, in one example, the first radiation has a source including a laser or other directed source that generates locally-focused radiation waves directed substantially on adhesive material **34**. In this case, in one optional aspect, changing adhesive component **34** to the substantially fully polymerized state may include additionally exposing adhesive component **34** to the first radiation for a second time period. In a different optional aspect, changing the adhesive component to the substantially fully polymerized state may include additionally exposing the adhesive component to a

second radiation for a second time period and/or at a second set of one or more wavelengths different from the first set of one or more wavelengths. For example, the second radiation may have a source including a different type of laser or other directed light source, or may include an ambient radiation source operable to generate non-locally-focused light waves, i.e. radiation or light waves not directed primarily on the adhesive component or the scaffold material.

[0041] Optionally, in some aspects, adhesive component **34** (and/or scaffold material **36** or **37**) may have a different perceived color at each material state. Thus, by changing from one perceived color to another, which includes a shift in wavelength (for example, from red to blue) or a shift in intensity (for example, from light blue to dark blue), adhesive component **34** may provide a perceptible visual indicator corresponding to the respective material state, thereby aiding a surgeon or other party in ascertaining the material state.

[0042] As noted above, although composite bone structure **70** or **71** has been discussed in terms of bones **30** and **32** or **30**, **32** and **33**, any number of bones may be utilized. Similarly, one or more composite bone structures **70** or **71** may be joined together, or composite bone structure **70** or **71** and non-harvested bone, such as adjacent to the site of hard tissue defect **10**, **11** or **12**, may be joined together in a similar manner as described above for joining two or more bones **30** and **32**, or **30**, **32** and **33**.

[0043] For example, the method of joining composite bone structure to another bone may include positioning the composite bone structure adjacent to at least one other bone at the implant site. Further, the method may include positioning a second scaffold material including a second adhesive component across at least a portion of each of the composite bone structure and the at least one other bone such that the second adhesive component is in contact with both the composite bone structure and the at least one other bone. When performing the conforming and the contacting, the second scaffold material and the second adhesive component both comprise a material state being substantially flexible. Finally, this method includes fixating the composite bone structure and the at least one other bone based on changing at least the second adhesive component to another material state at which the second adhesive component chemically or mechanically binds to the second scaffold material, the composite bone structure and the at least one other bone, thereby forming a structure having a desired rigidity, as described above.

[0044] Additionally, it should be noted that although FIGS. **4** and **5** include bone segments **30** and **32** having periosteum **50**, one or both of bone segments **30** and **32** may be obtained without periosteum **50**, such as in the case of one or both segments **30** and **32** comprising allograft bone or as in the case where the periosteum is removed from the patient's own bone intraoperatively.

[0045] In another example, in some aspects, the method of FIG. **2** may be utilized specifically for craniomaxillofacial surgery. In this case, for example, the method of craniomaxillofacial surgery includes accessing at least two bones at least partially defining a hard tissue defect at a location within a body, wherein the location comprises a cranial location or a maxillofacial location or mandible. In this case, at least one of the bones may be obtained from the defect location, while one or more of the other bones may be obtained from another harvesting location on the body, or may be obtained as an allograft. In other cases, such as when a reconstruction is desired using the existing hard tissue, the bones may be

obtained from the hard tissue location. Further, it should be noted that at least one of the bones may be a portion of cranial or maxillofacial bone at or adjacent to the hard tissue defect location and connected to or integral with the skull. Additionally, in this specific example, the hard tissue defect location comprises one of a cranial location or a maxillofacial location.

[0046] Further, the method of craniomaxillofacial surgery includes positioning the bones into a desired relative orientation. Generally, the bones are positioned such that opposing surfaces of the respective bone segments are facing one another, thereby defining an interface between the bone segments.

[0047] Additionally, the method of craniomaxillofacial surgery includes conforming a scaffold material to at least a portion of a surface of each of the bones. Further, the method includes contacting an adhesive component between at least a portion of each of the bones and the scaffold material. In this case, for example, the scaffold material spans the interface between the bones, thereby allowing the adhesive component to define a connection between the bones and the scaffold material. Additionally, to enable achieving a desired contact between the scaffold material and adhesive component and the bones, the scaffold material and the adhesive component both comprise a first material state being substantially flexible to allow such contact.

[0048] Additionally, the method of craniomaxillofacial surgery includes fixating the bones and the scaffold material in the desired relative orientation to remodel the hard tissue defect. In this case, the fixating is based on changing at least the adhesive component to a second material state at which the adhesive component mechanically or chemically binds the bones and the scaffold material, thereby forming a composite bone structure having a desired rigidity. In an optional aspect, the fixating may involve both the adhesive component and the scaffold material changing into the second material state to define the relatively rigid structure used to repair the hard tissue defect.

[0049] Thus, referring again to FIGS. 3-5 and 7, the above-described methods allow for the formation of a composite bone structure **70** (FIG. 5) or **71** (FIG. 7) that includes hard tissues/bones **30** and **32**, or **30**, **32** and **33**, joined together by an adhesive component **34** carried by a scaffold material **36** or **37**. For example, referring to FIGS. 3-5, hard tissue/bone **30** has a first surface **52** and hard tissue/bone **32** has a second surface **54**, and bones **30** and **32** are relatively positioned so as to define an interface **68** between at least a portion of the respective surfaces **52** and **54**. Further, scaffold material **36** is positioned adjacent to at least a portion of the hard tissues/bones **30** and **32**, such that scaffold material **36** spans at least a portion of interface **68**. Further, adhesive component **34** is in contact with at least a portion of each of the hard tissues/bones **30** and **32** and scaffold material **36**. Scaffold material **36** and adhesive component **34** both initially comprise a first material state being substantially flexible to enable their positioning relative to the respective hard tissues/bones **30** and **32**. After achieving the desired positioning, at least adhesive component **34** is changeable to a second material state at which adhesive component **34** binds to each of the hard tissues/bones **30** and **32** and scaffold material **36**, thereby defining composite bone structure **70** having a desired rigidity. Similarly, with respect to FIG. 7, scaffold material **37** wraps around hard tissues/bones **30**, **32** and **33**, and adhesive component **34** affixes the hard tissues/bones **30**, **32** and **33** and

scaffold material **37** in a desired orientation and further defines composite bone structure **71** having a desired rigidity.

[0050] While the foregoing disclosure discusses illustrative aspects and/or embodiments, it should be noted that various changes and modifications could be made herein without departing from the scope of the invention as defined by the appended claims. Furthermore, although elements of the described aspects and/or embodiments may be described or claimed in the singular, the plural is contemplated unless limitation to the singular is explicitly stated. Additionally, all or a portion of any aspect and/or embodiment may be utilized with all or a portion of any other aspect and/or embodiment, unless stated otherwise.

What is claimed is:

1. A method of fixating bone, comprising:
 - connecting at least two bones and a scaffold material with an adhesive component such that the adhesive component is in contact with at least a portion of a surface of each of the bones and the scaffold material; and
 - fixating the bones and the scaffold material to define a desired structure having a desired rigidity based on changing a material state of the adhesive component.
2. The method of claim 1, wherein the fixating further comprises changing the material state of the adhesive component so that the desired rigidity substantially corresponds to a rigidity of the bones.
3. The method of claim 1, wherein the adhesive component comprises a synthetic polymer, and wherein the fixating further comprises exposing the adhesive component to a radiation-based initiator or a chemical-based initiator operable to change the adhesive component to a cured state.
4. The method of claim 1, wherein the adhesive component comprises a synthetic polymer, and wherein the fixating further comprises polymerizing the adhesive component to a partial polymerization state, repositioning at least one of the bones while connected to the adhesive component in the partial polymerization state, and allowing or actively promoting further polymerizing of the adhesive component from the partial polymerization state to a substantially full polymerization state to fixate the repositioned bones and the scaffold material.
5. The method of claim 4, wherein changing the adhesive component to the substantially full polymerization state further comprises exposing the adhesive component to an ambient radiation source not directed primarily on the adhesive component or the scaffold material.
6. The method of claim 1, wherein changing the material state of the adhesive component further comprises changing the adhesive component from a first perceived color to a second perceived color, wherein the second perceived color is perceptively different from the first perceived color.
7. The method of claim 1, wherein the scaffold material comprises a first biocompatible material and the adhesive component comprises a second biocompatible material, wherein the first biocompatible material and the second biocompatible material have substantially similar rates of resorption.
8. The method of claim 1, wherein the scaffold material and the adhesive component both comprise substantially the same biocompatible material.
9. The method of claim 1, wherein the adhesive component comprises at least one material selected from the group comprising: urethane-based, resorbable synthetic polymer and isocyanate-based, resorbable synthetic polymer.

10. The method of claim 1, in which the bones are obtained from at least one location selected from the group comprising: a cranial skeleton location and a maxillofacial skeleton location.

11. The method of claim 1, further comprising adding an effective amount of the adhesive component to the scaffold material.

12. The method of claim 1, further comprising holding the bones in a desired relative orientation, conforming the scaffold material to at least a portion of the surface of each of the bones while positioned in the desired relative orientation, and changing the material state of the adhesive component after the conforming and while the bones are positioned in the desired relative orientation.

13. The method of claim 12, wherein the holding further comprises holding against a surface of a mold.

14. The method of claim 12, wherein the conforming further comprises changing a material state of the scaffold material.

15. The method of claim 1, further comprising:
accessing the bones at a location within a body;
removing the bones from the body;
holding the bones in a desired relative orientation outside of the body;
conforming the scaffold material to at least a portion of a surface of each of the bones while positioned in the desired relative orientation outside of the body;
changing the material state of the adhesive component after the conforming and while the bones are positioned in the desired relative orientation outside of the body; and
securing the fixated bones and scaffold material to at least a portion of a skeletal bone at the location within the body.

16. The method of claim 1, further comprising performing a surface preparation on at least a portion of the surface of each of the bones, wherein the surface preparation improves an ability of the adhesive component to attach to the respective portion of the surface.

17. The method of claim 16, wherein performing the surface preparation further comprises roughening the portion of the surface of each of the bones, and wherein connecting further comprises placing the scaffold material such that the adhesive component contacts the respective roughened surfaces.

18. The method of claim 16, wherein performing the surface preparation further comprises removing at least a portion of periosteum from at least the portion of the surface of each of the bones prior to the connecting with the scaffold material.

19. The method of claim 18, further comprising replacing the portion of the periosteum over the scaffold material at each portion of the surface of the bones after connecting the bones with the scaffold material.

20. The method of claim 1, further comprising adding a bone void filler between at least a portion of the bones.

21. The method of claim 1, further comprising adding a bone growth-promoting material in contact with the bones.

22. A method of craniomaxillofacial surgery, comprising:
accessing at least two bones at least partially defining a hard tissue defect at a location within a body, wherein the location comprises a cranial location or a maxillofacial location;
positioning the bones into a desired relative orientation;
conforming a scaffold material to at least a portion of a surface of each of the bones;
contacting an adhesive component between at least a portion of each of the bones and the scaffold material; and

fixating the bones and the scaffold material in the desired relative orientation to remodel the hard tissue defect, wherein the fixating is based on changing the adhesive component to a material state at which the adhesive component fastens together the bones and the scaffold material with a desired rigidity.

23. A composite bone structure, comprising:
a first bone having a first surface;
at least one other bone, wherein each other bone comprises a respective second surface;
a scaffold material positioned to connect the first bone and the at least one other bone, wherein the scaffold material is adaptable to conform to the first surface and each respective second surface; and
an adhesive component in contact with at least a portion of the first bone, each other bone and the scaffold material, wherein the adhesive component has a material state that is changeable to another material state at which the adhesive component affixes the first bone, each other bone and the scaffold material to define a composite bone structure having a desired rigidity.

24. The composite bone structure of claim 23, wherein the desired rigidity substantially corresponds to a rigidity of the first bone and each other bone.

25. The composite bone structure of claim 23, wherein the adhesive component comprises a synthetic polymer, wherein the another material state comprises a cured state, and wherein the synthetic polymer is operable to change to the cured state based on exposure to a radiation-based initiator or a chemical-based initiator.

26. The composite bone structure of claim 23, wherein the adhesive component is further operable to change from a first perceived color prior to achieving the another material state to a second perceived color at the another material state, wherein the second perceived color is perceptively different from the first perceived color.

27. The composite bone structure of claim 23, wherein the scaffold material comprises a first biocompatible material and the adhesive component comprises a second biocompatible material, wherein the first biocompatible material and the second biocompatible material have substantially similar rates of resorption.

28. The composite bone structure of claim 23, wherein the scaffold material and the adhesive component each comprise substantially the same biocompatible material.

29. The composite bone structure of claim 23, wherein the scaffold material is operable to carry the adhesive component.

30. The composite bone structure of claim 23, wherein the adhesive component comprises a urethane-based, resorbable synthetic polymer.

31. The composite bone structure of claim 23, wherein at least the first bone or the at least one other bone comprises a cranial bone or a maxillofacial bone or a mandible.

32. The composite bone structure of claim 23, wherein the first bone and each other bone in the composite bone structure have a desired relative orientation.

33. The composite bone structure of claim 23, further comprising periosteum positioned on the scaffold material.

34. The composite bone structure of claim 23, further comprising a bone void filler positioned between at least two of the first bone and each other bone.

35. The composite bone structure of claim 23, further comprising a bone growth-promoting material positioned between at least two of the first bone and the at least one other bone.