



## INTERNATIONAL APPLICATION PUBLISHED UNDER THE PATENT COOPERATION TREATY (PCT)

<p>(51) International Patent Classification <sup>6</sup> : <b>A61F 9/007</b></p>	<p><b>A1</b></p>	<p>(11) International Publication Number: <b>WO 98/00078</b></p> <p>(43) International Publication Date: 8 January 1998 (08.01.98)</p>
<p>(21) International Application Number: PCT/GB97/01752</p> <p>(22) International Filing Date: 26 June 1997 (26.06.97)</p> <p>(30) Priority Data: 9613766.6      1 July 1996 (01.07.96)      GB</p> <p>(71) Applicant (for all designated States except US): LIFE SCIENCE RESOURCES LIMITED [GB/GB]; 5 High Green, Great Shelford, Cambridge CB2 5EL (GB).</p> <p>(72) Inventor; and (75) Inventor/Applicant (for US only): MASON, William [GB/GB]; Church Street Barns, Church Street, Great Shelford, Cambridge CB2 5EL (GB).</p> <p>(74) Agent: GILL JENNINGS &amp; EVERY; Broadgate House, 7 Eldon Street, London EC2M 7LH (GB).</p>		<p>(81) Designated States: AL, AM, AT, AU, AZ, BA, BB, BG, BR, BY, CA, CH, CN, CU, CZ, DE, DK, EE, ES, FI, GB, GE, GH, HU, IL, IS, JP, KE, KG, KP, KR, KZ, LC, LK, LR, LS, LT, LU, LV, MD, MG, MK, MN, MW, MX, NO, NZ, PL, PT, RO, RU, SD, SE, SG, SI, SK, SL, TJ, TM, TR, TT, UA, UG, US, UZ, VN, YU, ZW, ARIPO patent (GH, KE, LS, MW, SD, SZ, UG, ZW), Eurasian patent (AM, AZ, BY, KG, KZ, MD, RU, TJ, TM), European patent (AT, BE, CH, DE, DK, ES, FI, FR, GB, GR, IE, IT, LU, MC, NL, PT, SE), OAPI patent (BF, BJ, CF, CG, CI, CM, GA, GN, ML, MR, NE, SN, TD, TG).</p> <p><b>Published</b> <i>With international search report.</i></p>
<p>(54) Title: MEDICAL LASER GUIDANCE APPARATUS</p>		
<p>(57) Abstract</p>		
<p>An apparatus for applying laser light to the retina of the eye comprises a retina image obtaining means for obtaining the image of a retina. A retina image display displays the required retina image, and reference data receiving means receives, from an operator, data relating to a treatment to be performed. Template generating means generates a reference template on the retina image, and target position receiving means receives data related to at least one target point to which light is to be applied based upon the received reference data. Current retina position detecting means acquires a current retina image, and laser light application means directs and applies laser light to a retina.</p>		

**FOR THE PURPOSES OF INFORMATION ONLY**

Codes used to identify States party to the PCT on the front pages of pamphlets publishing international applications under the PCT.

AL	Albania	ES	Spain	LS	Lesotho	SI	Slovenia
AM	Armenia	FI	Finland	LT	Lithuania	SK	Slovakia
AT	Austria	FR	France	LU	Luxembourg	SN	Senegal
AU	Australia	GA	Gabon	LV	Latvia	SZ	Swaziland
AZ	Azerbaijan	GB	United Kingdom	MC	Monaco	TD	Chad
BA	Bosnia and Herzegovina	GE	Georgia	MD	Republic of Moldova	TG	Togo
BB	Barbados	GH	Ghana	MG	Madagascar	TJ	Tajikistan
BE	Belgium	GN	Guinea	MK	The former Yugoslav Republic of Macedonia	TM	Turkmenistan
BF	Burkina Faso	GR	Greece	ML	Mali	TR	Turkey
BG	Bulgaria	HU	Hungary	MN	Mongolia	TT	Trinidad and Tobago
BJ	Benin	IE	Ireland	MR	Mauritania	UA	Ukraine
BR	Brazil	IL	Israel	MW	Malawi	UG	Uganda
BY	Belarus	IS	Iceland	MX	Mexico	US	United States of America
CA	Canada	IT	Italy	NE	Niger	UZ	Uzbekistan
CF	Central African Republic	JP	Japan	NL	Netherlands	VN	Viet Nam
CG	Congo	KE	Kenya	NO	Norway	YU	Yugoslavia
CH	Switzerland	KG	Kyrgyzstan	NZ	New Zealand	ZW	Zimbabwe
CI	Côte d'Ivoire	KP	Democratic People's Republic of Korea	PL	Poland		
CM	Cameroon	KR	Republic of Korea	PT	Portugal		
CN	China	KZ	Kazakstan	RO	Romania		
CU	Cuba	LC	Saint Lucia	RU	Russian Federation		
CZ	Czech Republic	LI	Liechtenstein	SD	Sudan		
DE	Germany	LK	Sri Lanka	SE	Sweden		
DK	Denmark	LR	Liberia	SG	Singapore		
EE	Estonia						

MEDICAL LASER GUIDANCE APPARATUS

This invention relates to a medical laser guidance apparatus.

5 In recent years laser light has been used to assist in the treatment of a number of ailments. One particular application of laser light has been in the treatment of eye disease by the application of laser light to the retina of an eye. Traditionally, such treatment has involved  
10 preliminary inspection of the eye using a fundus camera, slit lamp or similar optical viewing device followed by movement of the patient to a separate location for laser treatment of the eye. With such treatment, the laser is often applied days or weeks after the initial inspection,  
15 in view of the need to develop photographs taken by the fundus camera and the time required to analyse such photographs. Furthermore, once laser treatment is started, a number of sessions may be required, as the treatment is time consuming and traumatic for the patient, due to the  
20 need to compare the retina to be treated with earlier photographs. This, in turn, leads to the operator and patient tiring, making lengthy treatment sessions difficult to tolerate.

In order to overcome some of the above problems, it  
25 has been proposed to incorporate a laser treatment apparatus within a fundus camera. Such a system, whilst enabling the laser treatment of the retina to be performed at the same time as initial inspection, is extremely expensive in view of the large number of components  
30 required to provide a combined camera and laser application device. Furthermore, even with such systems it has been difficult to track a retina accurately throughout the inspection and treatment process, making the possibility of erroneous application of treatment light very high.

35 The present invention is directed towards solving some of the above problems.

According to the present invention there is provided an apparatus for applying laser light to at least one selected location on the retina of the eye, the apparatus comprising:

5 retina image obtaining means for obtaining the image of a retina;

retina image display means for displaying the required retina image;

10 reference data receiving means for receiving, from an operator, data relating to a treatment to be performed;

template generating means for generating a reference template on the retina image;

15 target position receiving means for receiving data related to at least one target point to which light is to be applied based upon the received reference data;

20 current retina position detecting means for acquiring a current retina image from the retina image acquisition means and comparing it to the generated template and said reference data and outputting a signal indicating current retina position within said template; and

laser light application means for directing and applying laser light to a retina dependent upon the output of the current retina position detecting means and the target position receiving means.

25 The reference data may include data relating to at least one reference point selected by an operator within the retina image.

30 An operator can view the position of low level laser light emitted by the laser light source by viewing the retina through the eye piece of the fundus camera, slit lamp or similar viewing apparatus, and can apply a treatment level of laser light to a selected point or area of a patient's retina by appropriate application of commands to the control means.

35 Alternatively, a video camera may be attached to the output of the viewing apparatus. The video camera output can be displayed on a video monitor for ease of viewing.

With either arrangement points on the retina may be selected for laser treatment by simple operation of a mouse, trackball or the like with an output connected to the target receiving means. With such an arrangement, semi-automated control of the laser is also possible by providing real time or near real time image recognition means which receives selected point or area data from an operator and then tracks the retina using video data from a camera and outputs treatment level laser light as required. This arrangement has the advantage that it can compensate for movements of the retina by the patient at a speed and accuracy that is not within the ability of a human operator.

A diffractive optical element may be placed within the optical path of the guidance apparatus in order to produce, from a single primary laser beam, an array of secondary treatment beams, which can thus be used to speed up treatment over a selected area, in order to reduce treatment time and patient discomfort.

The laser light source may be a tube laser, solid state laser or a diode laser, which has the advantages of reduced weight, size, and power consumption. The laser light positioning means may be a galvanometer and mirror arrangement, or may include acousto-optical devices. The laser light positioning means may be employed to modulate the light emitted by the laser light source by directing it away from the viewing apparatus optical path in a pulsed manner. Alternatively the laser light source may be pulsed.

One example of apparatus according to the present invention will now be described with reference to the accompanying drawings, in which:-

Fig. 1 is a schematic diagram of a known fundus camera;

Fig. 2 is a schematic diagram of a guidance apparatus according to the present invention;

Fig. 3 is a schematic block diagram of a computer control guidance apparatus according to the present invention;

5 Fig. 4 is a diagram showing the operation of a diffractive optical element that may be employed in the present invention;

Fig. 5 is a diagram of a treatment template for an apparatus employing the diffractive optical element shown in Figure 4; and,

10 Fig. 6 is a schematic diagram showing an example image recognition technique employed with the present invention.

Fig. 1 shows a known fundus camera 1 which is employed to inspect the retina of an eye 3 which is to be treated. An illuminating light source 2 provides illuminating light to the eye 3, which light is then reflected back towards a viewing eyepiece 4 and camera 5. When a photograph of the retina is to be taken, a flash source 6 is activated and a photograph taken with the camera 5. A focusing system 7 is provided to focus the image of the retina for clear viewing by both the camera 5 and through the eyepiece 4.

20 Fig. 2 shows an example of the present invention being operated in conjunction with the known fundus camera 1 of Fig. 1. Corresponding components are identically numbered. It will be appreciated that this example could be adapted to operate in conjunction with a slit lamp or similar retina viewing apparatus. Attached to the objective lens 8 of the fundus camera 1 is a light directing element 9. The light directing element 9 comprises a circular beam stop 10 and prism 11. The prism 11 is arranged to direct light from a laser light source 12 into the optical path of the fundus camera 1 and on to the retina of the eye 3.

25 In this example, the laser light source 12 comprises a target laser light source 12a and a main pulse laser light source 12b. It will be appreciated, however, that a single laser light source, operating at two different power levels could be employed. In this example, the target laser light source may be a HeNe or red diode laser, and

35

the main pulse laser light source an argon or NdYg laser.

Light from the laser light source 12 is directed via a dichroic mirror 13 to a laser light positioning means 14 which is under the control of a laser light application means 15, in this example a computer, and comprises two X Y galvo mirrors. This arrangement may be substituted by an acousto-optical device placed in the light path. The light positioning means 14 operates via prisms to position light from the laser light source 12 within the optical path of the fundus camera 1 and to control the light's position on the retina of the eye. An optional diffractive element 16 is placed in the path of the light from the laser light source 12. The operation of this optional diffractive element 16 will be described later. It will be appreciated that many of these components could be placed within the camera housing if a dedicated apparatus were required.

Light from the laser light source 12 passes, in use, via the light directing means 9, on to the retina of the eye 3 and back into the fundus camera 1 via the objective lens 8. The light is then passed out, via the eyepiece 4 or a TV part (not shown) of the fundus camera 1, to a retina image receiving means 17, in this case a video camera 17. The output of the video camera 17 is, in this case, connected to a computer system.

Referring to Fig. 3, the overall operation of the apparatus according to the invention will now be described. Again, components corresponding to those described with reference to Figs. 1 and 2 are identically numbered. In this example, a display means (e.g. a monitor) 18 is provided to receive outputs from the control means 15 and hence to display images received by the video camera 17. Reference data receiving means 19, 20 are provided, and may be components such as a keyboard 19 and/or mouse 20, a joystick or foot pedal. The example shown in Fig. 3 provides a number of treatment options. The first option is complete control of the treatment by the laser light application means 15. With this option, laser light

application means receives data about the treatment from the reference data receiving means, and controls the output of the laser light source 12 employing tracking discussed below, together with the laser positioning means 14 to  
5 apply laser light to the retina of the eye 3. The laser light application means 15 is adapted, using appropriate real time image recognition discussed in the manner below, in combination with current retina position detecting means 15 to monitor the position of light from the laser light  
10 source relative to features on the retina of the eye, and to track the retina's position accordingly.

This example also enables a semi-automated process, in which particular points or areas on the retina are selected for treatment by an operator selecting points or areas  
15 displayed on the monitor 18. Once selection has been completed, the apparatus then proceeds to treat the selected points or areas by application of the required level of laser light from the laser light source 12 whilst tracking the eye.

20 Fig. 4 shows the optional diffractive optical element 16 shown in Fig. 2. This light diffractive element 16 diffracts a single laser beam 30 into a laser beam array 31 which, in this case, is a three-by-three matrix. It will be appreciated that matrices of other sizes could also be  
25 produced. The provision of this diffractive optical element 16 enables the application of laser light to multiple points in a single application, speeding up the treatment process, and reducing discomfort to the patient. As can be seen from Fig. 5, with a three-by-three  
30 diffractive optical element 16, the application of eight separate pulses, providing eight arrays of application points A to H, which can cover a large area of the retina 3 when the diffractive optical element 16 is provided.

The apparatus may incorporate a laser control  
35 algorithm which spatially and or temporarily randomises or disperses application of light to selected treatment parts.



Fig. 6 shows an example of one image recognition process that may be used in conjunction with the apparatus of the present invention. This process, performed by the computer 15, employs the outline of the optic nerve as a reference point on the retina (although an alternative reference may be employed by an operator), and searches through the output of the video camera 17 until a match is produced. The current retina position detecting means 15 can then track the position of the retina 3 through both voluntary and involuntary eye movements by locking into and following the optic nerve position, or another topographical feature of the retinal image such as a blood vessel, for example. The process may be employed with the invention, or may be employed in any combined retina viewing device employing laser treatment and appropriate image capturing, processing and laser control circuitry. The process of this example employs a cross-correlation function of the type

$$R_{ft}(u,v) = \sum_{x=-M}^M \sum_{y=-N}^N f(x,y) \cdot t(x-u,y-v)$$

where an image  $F(X,Y)$  and template  $T(X,Y)$ , are captured and generated respectively. It will be appreciated that alternative functions may be employed.

This function is at a maximum when a portion of image  $F$  which is under template  $T$  as exactly the same as  $T$ . This can then form a simple goodness-fit measure, having a range from 0 to 1 by computing

$$R_{ft}(u,v)/R_{tt}(u,v).$$

Where  $R_{tt}$  is computed once, before any matching has to be done.

The deviation of the current captured image from a reference image (and its corresponding template) yields a number in  $X$  and  $Y$  dimensions which is essentially an estimate of deviation. This number can then be employed to drive laser light deflecting means to correctly align the laser beam to a selected target.

This process is particularly useful if an automated or pre-stored treatment data course of treatment is required.

5 It will be appreciated that the overall control of the present invention can be provided by any suitable computer or microprocessor based system. For example a PC, Apple MacIntosh or other work station system with appropriate software and control interfaces. This means that control of the system can be realised with high reliability and at relatively low cost.

CLAIMS

1. An apparatus for applying laser light to at least one selected location on the retina of the eye, the apparatus  
5 comprising:  
    retina image obtaining means for obtaining the image of a retina;  
    retina image display means for displaying the required retina image;  
10      reference data receiving means for receiving, from an operator, data relating to a treatment to be performed;  
    template generating means for generating a reference template on the retina image;  
    target position receiving means for receiving data  
15 related to at least one target point to which light is to be applied based upon the received reference data;  
    current retina position detecting means for acquiring a current retina image from the retina image acquisition means and comparing it to the generated template and said  
20 reference data and outputting a signal indicating current retina position within said template; and  
    laser light application means for directing and applying laser light to a retina dependent upon the output of the current retina position detecting means and the  
25 target position receiving means.
2. An apparatus according to claim 1, wherein the reference data receiving means receives data relating to at least one reference point selected by an operator.  
30
3. An apparatus according to claims 1 or 2, wherein the relationship between the generated template and the current retina position is obtained by the current retina position means by employing a confidence level algorithm.  
35

4. An apparatus according to claim 3, wherein the confidence level algorithm employs a cross-correlation function.
- 5 5. An apparatus according to any of the preceding claims, further including a laser light output inhibiting means for inhibiting laser light output if the detected current retina position cannot be aligned with the template.
- 10 6. An apparatus according to any of the preceding claims, further including a laser light output inhibiting means for inhibiting laser light output if an error in the apparatus is detected.
- 15 7. An apparatus according to any of the preceding claims, which can be attached to a viewing apparatus.
- 20 8. An apparatus according to claim 7, wherein an operator views the position of low level laser light emitted by a laser light source by viewing the retina through an eye piece of the viewing apparatus.
- 25 9. An apparatus according to claims 7 or 8, wherein the viewing apparatus comprises a fundus camera.
10. An apparatus according to claims 7 or 8, wherein the viewing apparatus comprises a slit lamp.
- 30 11. An apparatus according to claim 7 or claim 8, wherein a video camera is attached to the output of the viewing apparatus and the video camera output is displayed on a video monitor.
- 35 12. An apparatus according to any of the preceding claims, wherein points on the retina may be selected for laser treatment by a user.

13. An apparatus according to claim 12, wherein the points are selected by means of a mouse or trackball with an output connected to the reference data receiving means.
- 5 14. An apparatus according to any of the preceding claims, further comprising a diffractive optical element placed within the optical path of the laser light application means, such that, from a single primary laser beam, an array of secondary treatment beams are produced.
- 10 15. An apparatus according to any of the preceding claims, wherein the laser light is from a tube laser.
- 15 16. An apparatus according to any of claims 1 to 14, wherein the laser light is from a solid state laser.
17. An apparatus according to any of claims 1 to 14, wherein the laser light is from a diode laser.
- 20 18. An apparatus according to any of the preceding claims, wherein the laser light application means employs a galvanometer and mirror arrangement.
- 25 19. An apparatus according to any the preceding claims, wherein the laser light application means includes acousto-optical devices.
- 30 20. An apparatus according to any of the preceding claims wherein the laser light application means is employed to modulate the light emitted by the laser light source by directing it away from the eye in a pulsed manner.
- 35 21. An apparatus according to any of claims 1 to 8, wherein the laser light source is pulsed.

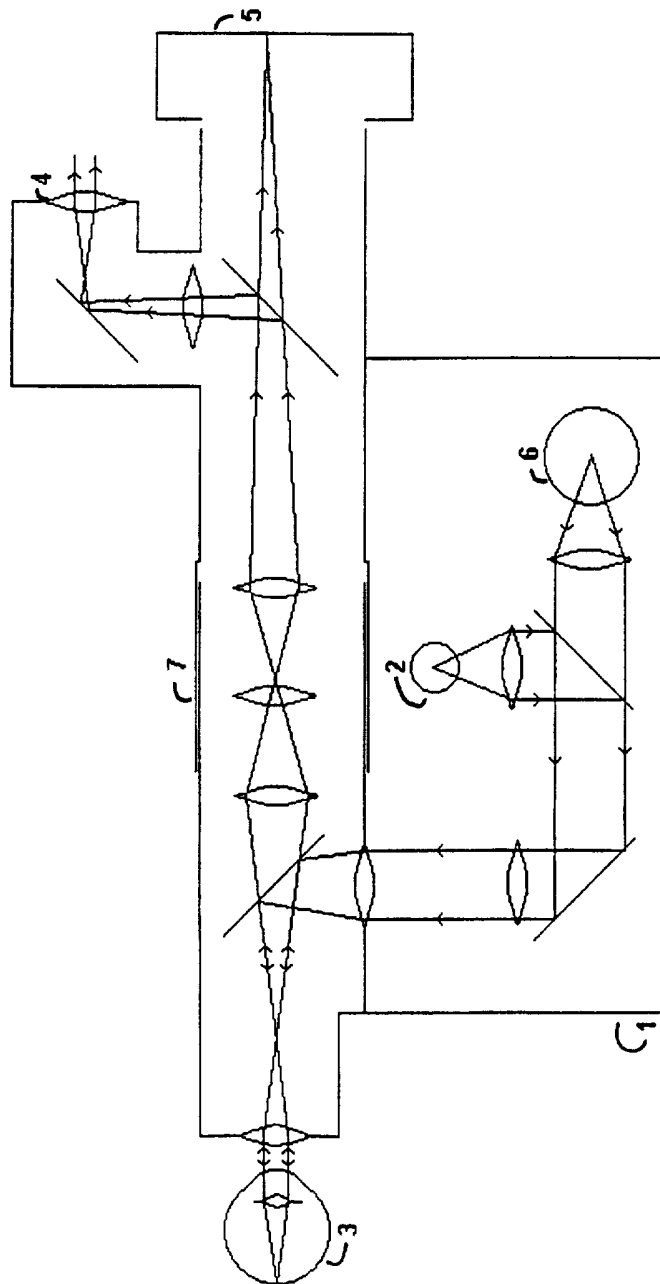

Figure 1

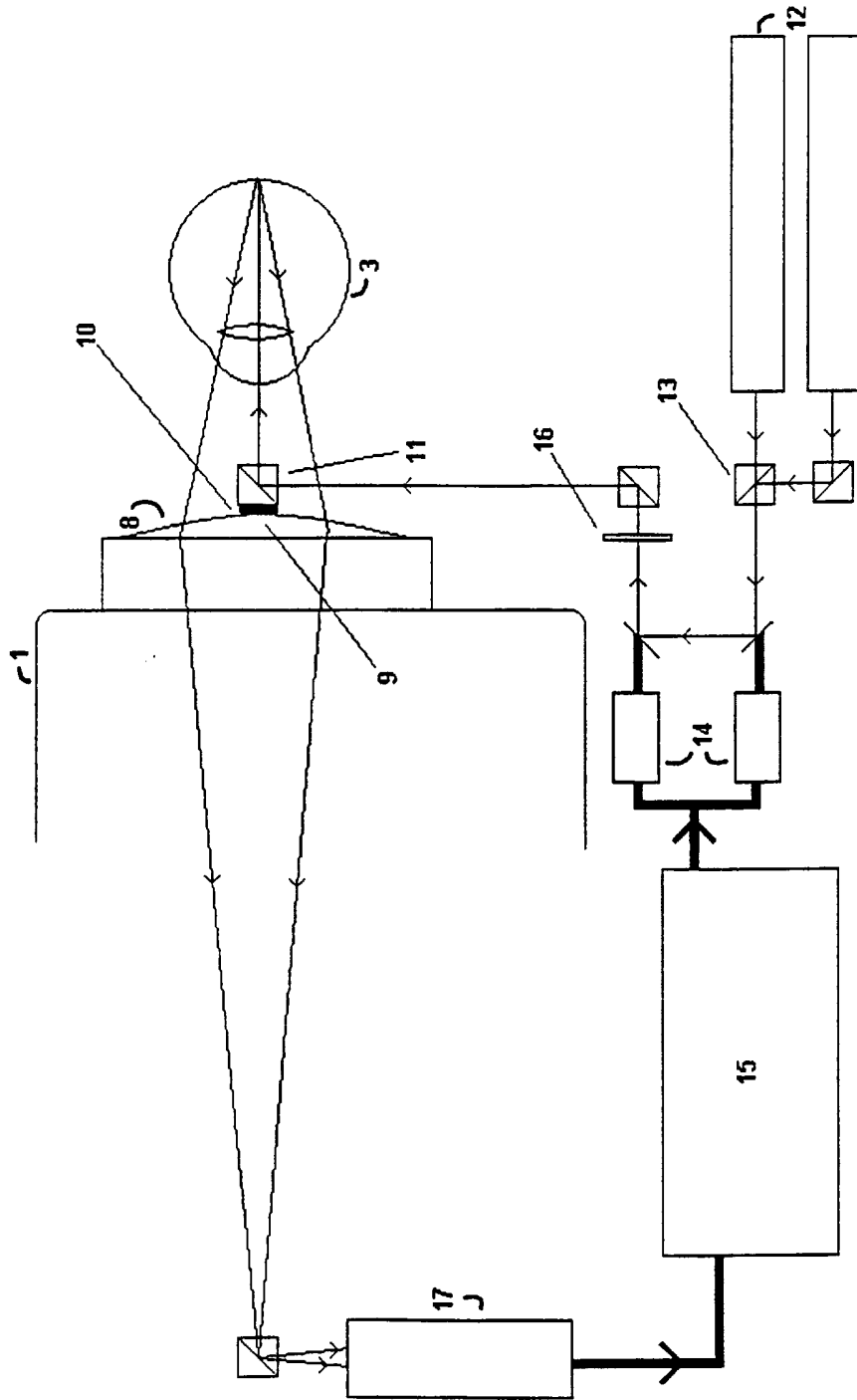

Figure 2

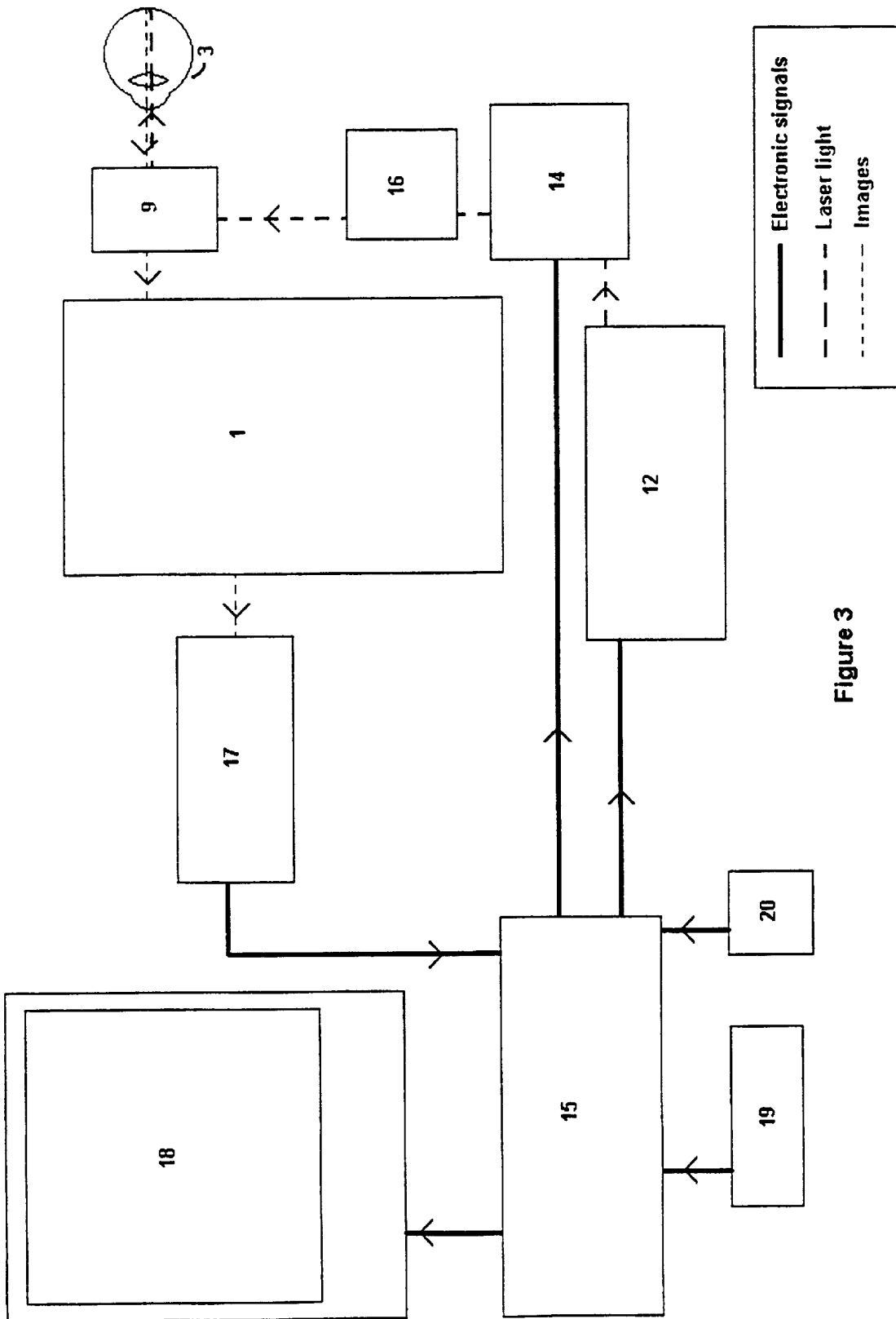

Figure 3



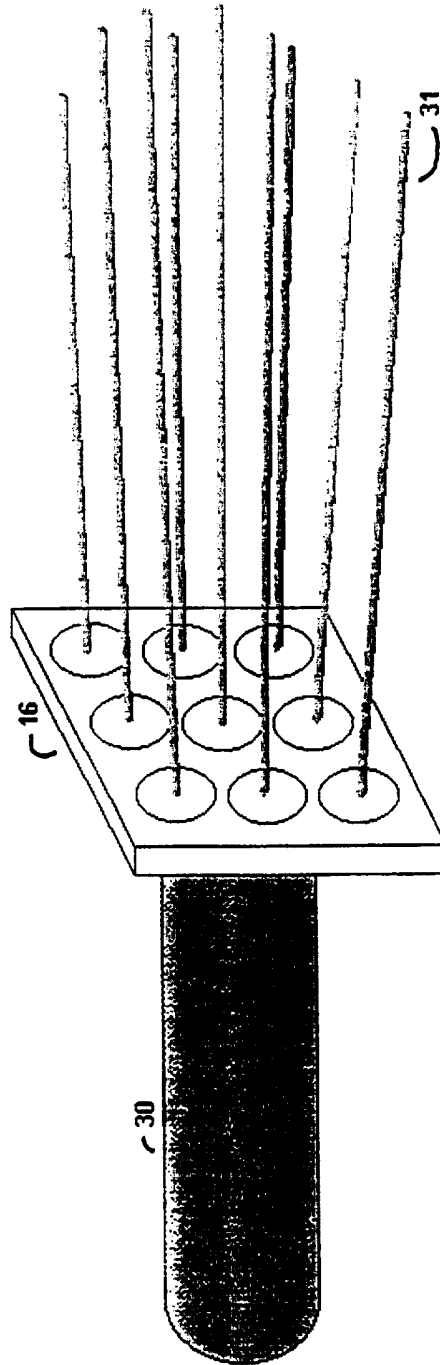
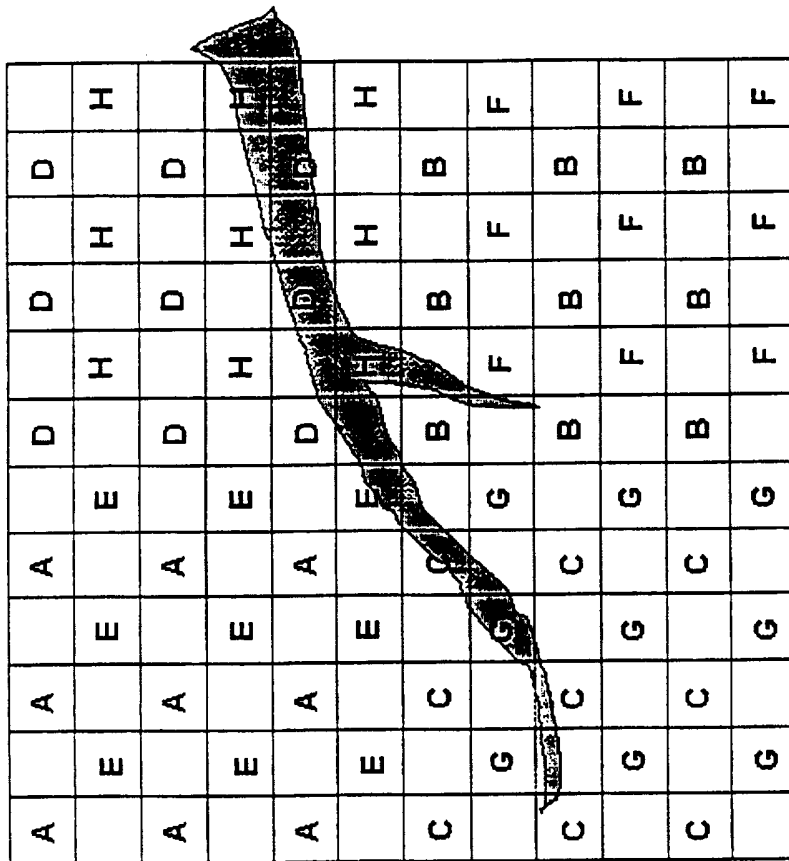

Figure 4



A		A		A		A		A	
	E		E		E		E		E
A		A		A		A		A	
	E		E		E		E		E
A		A		A		A		A	
	E		E		E		E		E
A		A		A		A		A	
	E		E		E		E		E
A		A		A		A		A	
	E		E		E		E		E

Figure 5

6/6

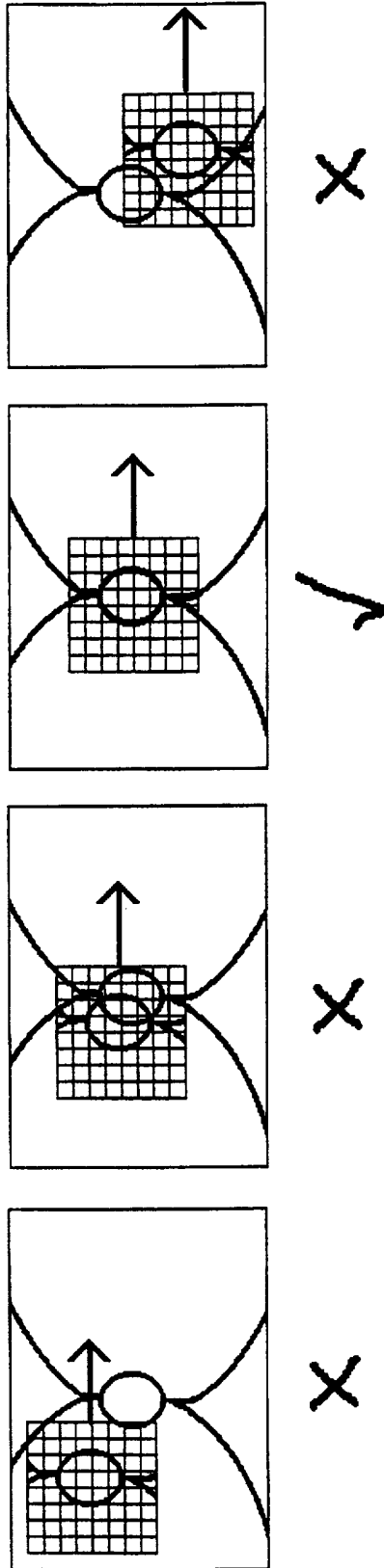

Figure 6

# INTERNATIONAL SEARCH REPORT

International Application No

PCT/GB 97/01752

**A. CLASSIFICATION OF SUBJECT MATTER**  
IPC 6 A61F9/007

According to International Patent Classification (IPC) or to both national classification and IPC

**B. FIELDS SEARCHED**

Minimum documentation searched (classification system followed by classification symbols)

IPC 6 A61F

Documentation searched other than minimum documentation to the extent that such documents are included in the fields searched

Electronic data base consulted during the international search (name of data base and, where practical, search terms used)

**C. DOCUMENTS CONSIDERED TO BE RELEVANT**

Category *	Citation of document, with indication, where appropriate, of the relevant passages	Relevant to claim No.
X	US 5 029 220 A (JUDAY RICHARD D) 2 July 1991	1-6, 11-13,18
Y	see column 8, line 9 - line 30; claim 5; figure 4	7-10, 14-17, 19-21
X	--- WO 93 16631 A (PHOENIX) 2 September 1993 see claims 1,2,14,20,21	1-6
X	--- WO 87 05205 A (RODENSTOCK INSTR) 11 September 1987 see claims 1-10,14; figure 1	1-6
Y	--- WO 91 01703 A (SCIENTIFIC GENERICS) 21 February 1991 see page 6, line 13 - page 7, line 19	7-10
A	see page 9, line 30 - page 10, line 15; figure 1 ---	17
	-/--	

Further documents are listed in the continuation of box C.

Patent family members are listed in annex.

\* Special categories of cited documents :

- \*A\* document defining the general state of the art which is not considered to be of particular relevance
- \*E\* earlier document but published on or after the international filing date
- \*L\* document which may throw doubts on priority claim(s) or which is cited to establish the publication date of another citation or other special reason (as specified)
- \*O\* document referring to an oral disclosure, use, exhibition or other means
- \*P\* document published prior to the international filing date but later than the priority date claimed

- \*T\* later document published after the international filing date or priority date and not in conflict with the application but cited to understand the principle or theory underlying the invention
- \*X\* document of particular relevance; the claimed invention cannot be considered novel or cannot be considered to involve an inventive step when the document is taken alone
- \*Y\* document of particular relevance; the claimed invention cannot be considered to involve an inventive step when the document is combined with one or more other such documents, such combination being obvious to a person skilled in the art.
- \*G\* document member of the same patent family

Date of the actual completion of the international search

30 September 1997

Date of mailing of the international search report

13.10.97

Name and mailing address of the ISA

European Patent Office, P.B. 5818 Patentlaan 2  
NL - 2280 HV Rijswijk  
Tel. (+31-70) 340-2040, Tx. 31 651 epo nl,  
Fax: (+31-70) 340-3016

Authorized officer

Moers, R

## INTERNATIONAL SEARCH REPORT

International Application No

PCT/GB 97/01752

C.(Continuation) DOCUMENTS CONSIDERED TO BE RELEVANT		
Category *	Citation of document, with indication, where appropriate, of the relevant passages	Relevant to claim No.
Y	US 3 769 963 A (GOLDMAN ET AL.) 6 November 1973	14-17, 20,21
A	see column 6, line 28 - column 8, line 39; figures 1,2	7-10,12
	---	
Y	WO 90 08500 A (AESCULAP) 9 August 1990	19
A	see page 6, line 1 - page 10, paragraph 1; figure 1	2-13,18
	---	
A	US 4 443 075 A (CRANE HEWITT D) 17 April 1984	1,9
	see column 3, line 62 - line 64 see column 5, line 28 - column 7, line 13; figure 1	
	---	
A	US 5 376 086 A (KHOUBEHI ET AL.) 27 December 1994	1,14
	see column 5, line 7 - line 34; figure 1	
	---	
A	WO 88 03396 A (RODENSTOCK) 19 May 1988	1,19
	see page 16, line 28 - page 17, line 1	
	-----	

# INTERNATIONAL SEARCH REPORT

Information on patent family members

International Application No

PCT/GB 97/01752

Patent document cited in search report	Publication date	Patent family member(s)	Publication date
US 5029220 A	02-07-91	NONE	
WO 9316631 A	02-09-93	AU 3781193 A CA 2130999 A EP 0630205 A	13-09-93 02-09-93 28-12-94
WO 8705205 A	11-09-87	DE 3607721 A DE 3638226 A DE 3776042 A DE 3776242 A WO 8705204 A EP 0260286 A EP 0259398 A JP 1500009 T JP 2593085 B JP 63503277 T DE 3776650 A WO 8803396 A EP 0290566 A JP 1501527 T JP 3051408 B US 5177511 A	10-09-87 11-05-88 27-02-92 05-03-92 11-09-87 23-03-88 16-03-88 12-01-89 19-03-97 02-12-88 19-03-92 19-05-88 17-11-88 01-06-89 06-08-91 05-01-93
WO 9101703 A	21-02-91	AU 6061090 A EP 0485450 A JP 5500315 T	11-03-91 20-05-92 28-01-93
US 3769963 A	06-11-73	NONE	
WO 9008500 A	09-08-90	DE 3902410 A	02-08-90
US 4443075 A	17-04-84	NONE	
US 5376086 A	27-12-94	US 5571107 A	05-11-96
WO 8803396 A	19-05-88	DE 3638226 A DE 3776650 A WO 8705205 A EP 0259398 A EP 0290566 A	11-05-88 19-03-92 11-09-87 16-03-88 17-11-88

# INTERNATIONAL SEARCH REPORT

Information on patent family members

International Application No

PCT/GB 97/01752

Patent document cited in search report	Publication date	Patent family member(s)	Publication date
WO 8803396 A		JP 1501527 T	01-06-89
		JP 3051408 B	06-08-91
		JP 2593085 B	19-03-97
		JP 63503277 T	02-12-88
		US 5177511 A	05-01-93
-----			