

(12) **UK Patent Application** (19) **GB** (11) **2 359 996** (13) **A**

(43) Date of A Publication **12.09.2001**

(21) Application No **0102371.2**
(22) Date of Filing **30.01.2001**
(30) Priority Data
(31) **0002805** (32) **08.02.2000** (33) **GB**

(51) INT CL⁷
A61M 16/04 16/06
(52) UK CL (Edition S)
A5R RGEX
A5T TCT

(71) Applicant(s)
Smiths Industries Public Limited Company
(Incorporated in the United Kingdom)
765 Finchley Road, LONDON, NW11 8DS,
United Kingdom

(56) Documents Cited
GB 2334215 A GB 2330312 A WO 94/17848 A

(72) Inventor(s)
Mark William Doane
Jim Thomas

(58) Field of Search
UK CL (Edition S) **A5R RGEX , A5T TCT**
INT CL⁷ **A61M 16/04 16/06**
ONLINE: EPODOC, WPI, JAPIO

(74) Agent and/or Address for Service
J M Flint
Smiths Industries Public Limited Company,
765 Finchley Road, LONDON, NW11 8DS,
United Kingdom

(54) Abstract Title
Masks and their manufacture

(57) A mask 2, such as a laryngeal mask or face mask, has a soft annular cuff 21, on a more rigid mount 20 of funnel shape. The cuff 21 and mount 20 are moulded together preferably by rotational moulding (Figs 2, 3; not shown) or the mount 51 is preformed and the cuff 52 is moulded onto the mount in a rotational mould 60 (Figs 4, 5; not shown). The cuff is preferably hollow.

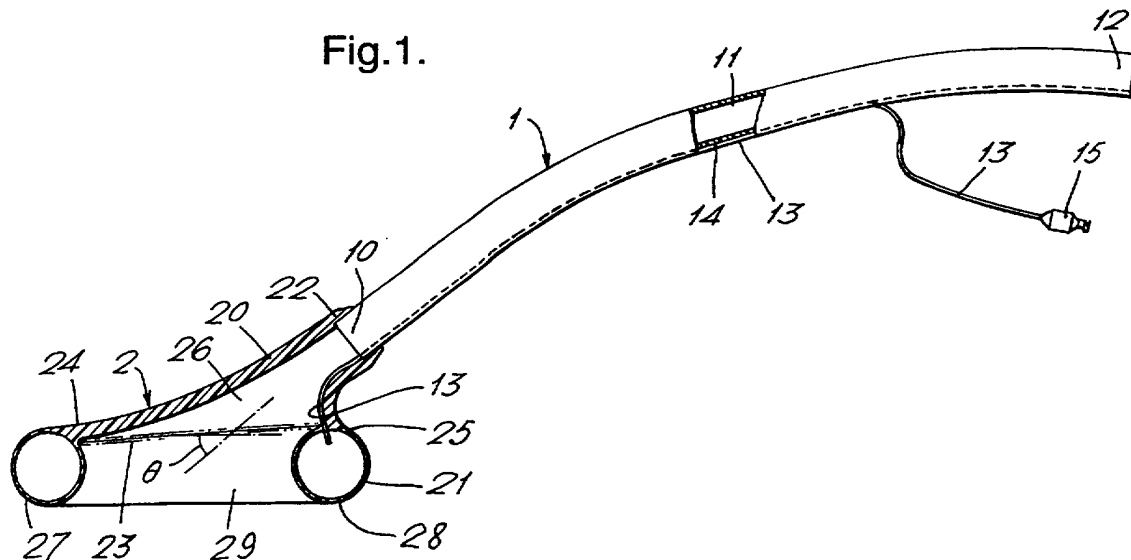

GB 2 359 996 A

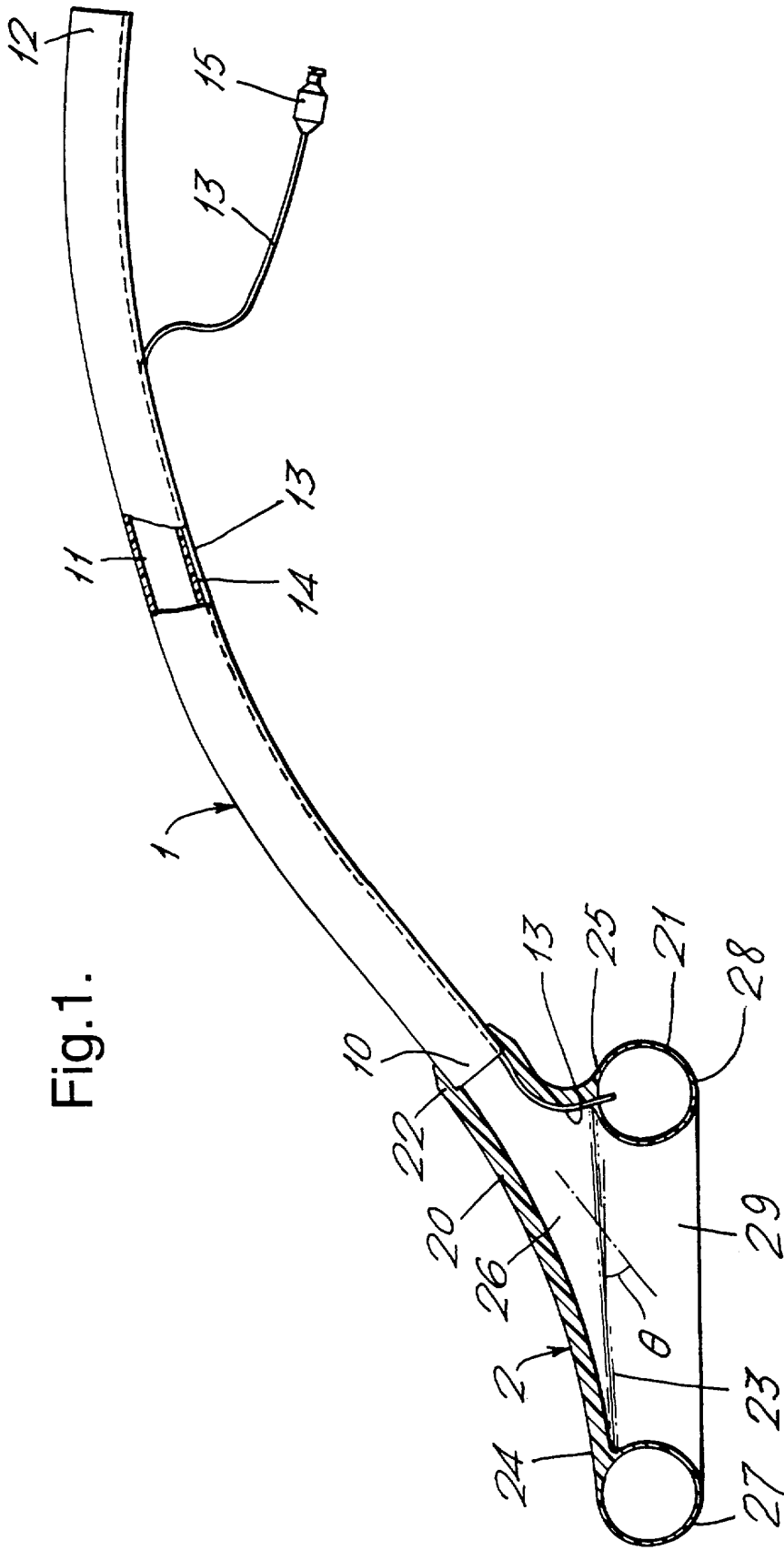

Fig.1.

Fig.2.

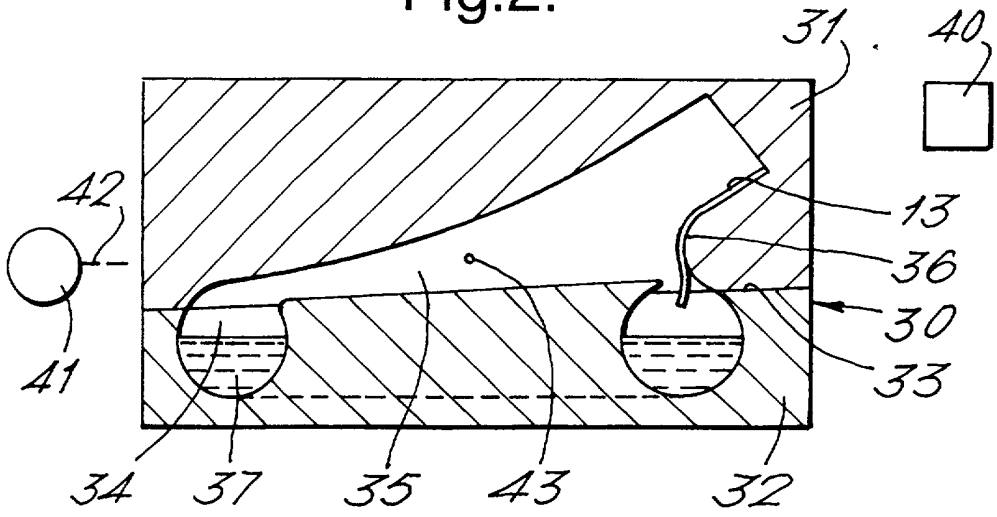

Fig.3.

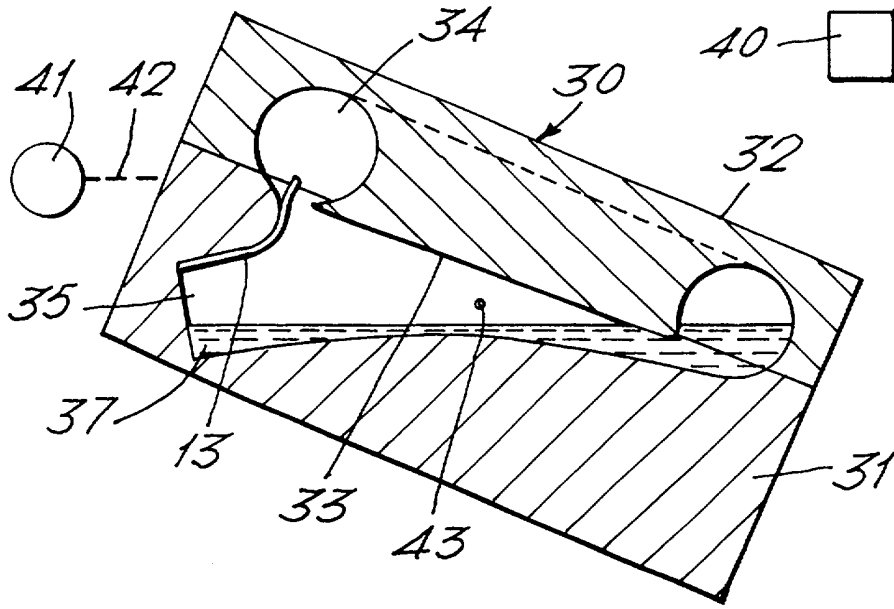

Fig.4.

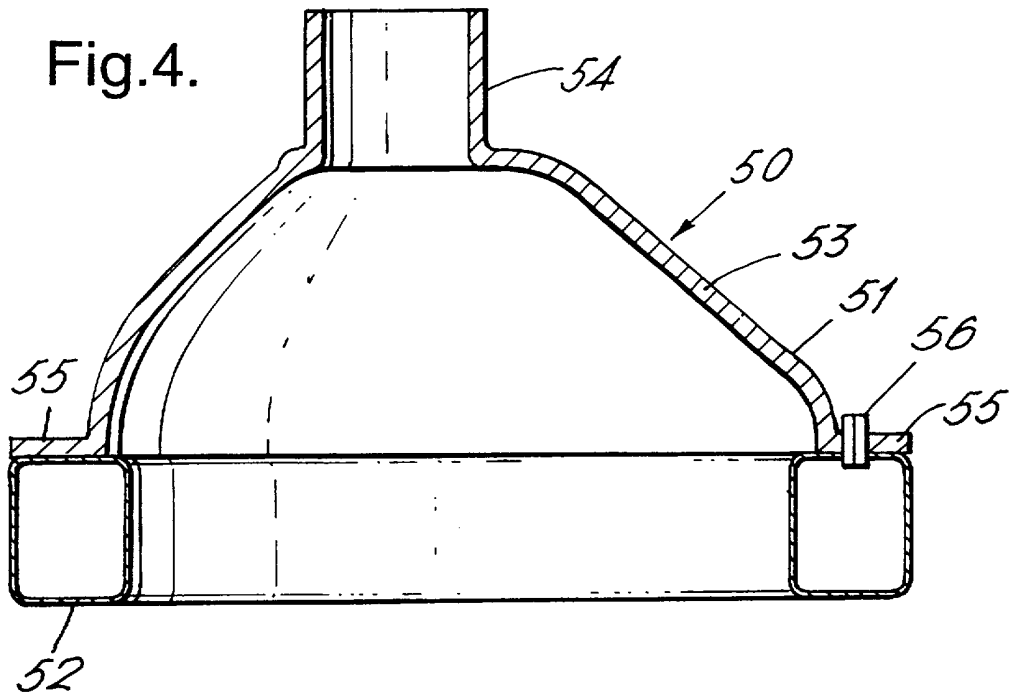
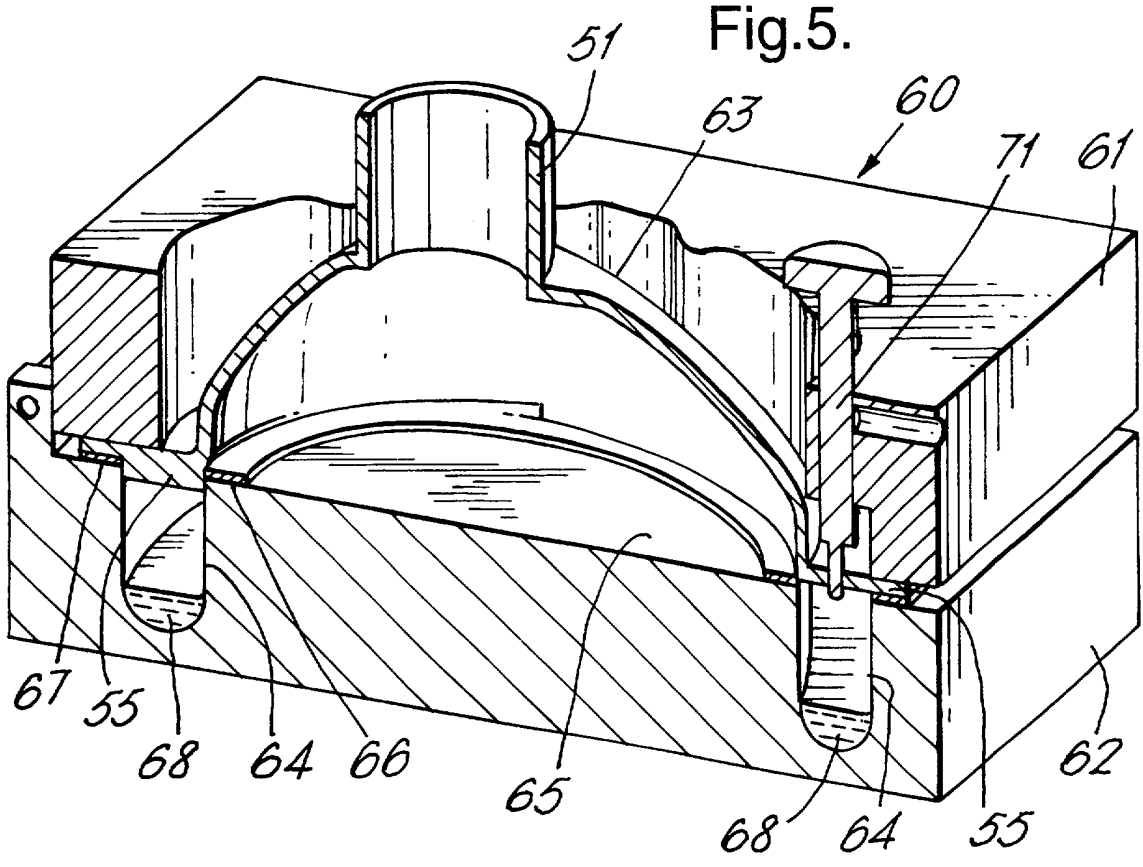
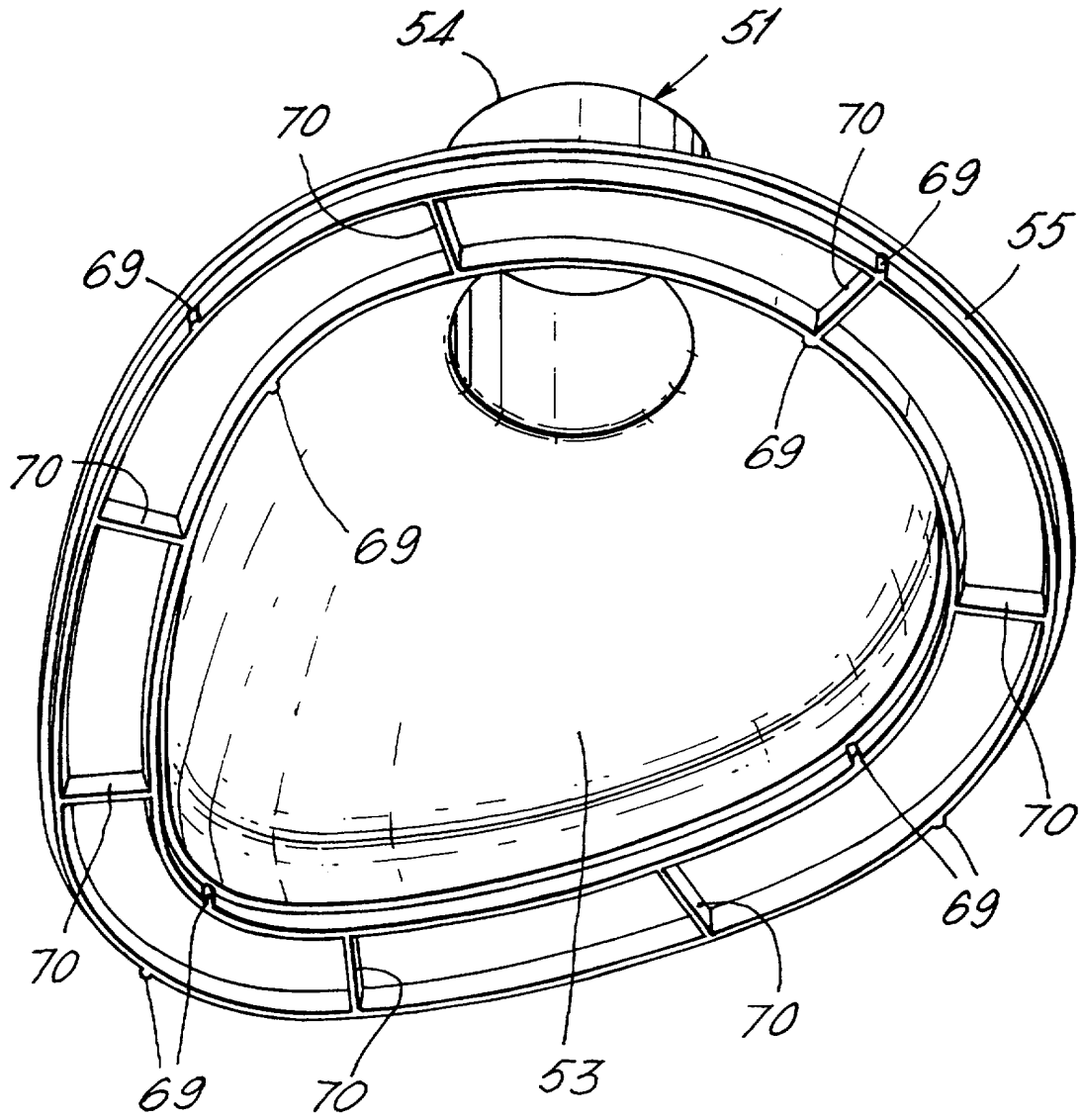

Fig.5.



4/4

Fig.6.



MASKS AND THEIR MANUFACTURE

This invention relates to masks and their manufacture.

Masks, such as face masks or laryngeal masks, comprise a relatively stiff mount, cone or shoe member and a softer, more flexible annular balloon, cuff or cushion extending around the edge of the mount, which conforms readily to the anatomy and makes sealing contact with the patient tissue. The cuff is formed separately from the mount and is subsequently joined with it, such as by means of an adhesive or solvent. The cuff may be made by an injection moulding or rotational moulding technique; the mount is usually made by an injection moulding technique. Examples of laryngeal masks and their manufacture are shown in US 5355879, US 5305743, US 5297547, US 5282464, GB 2267034, US 5249571, US 5241956, US 5303697, GB 2249959, GB 2111394, EP 448878, US 4995388, GB 2205499, GB 2128561, GB 2298797, GB 2334215, PCT/GB00/03045, PCT/GB00/03044 and GB 2337020.

Masks made in this way are relatively expensive because of the need for different manufacturing and assembly operations. The join between the mount and cushion provides a possible site for failure or leakage and requires testing to ensure an effective join. Where the mask is used internally, such as in a laryngeal mask, the consequences of separation of the cushion and mount can be severe. The join itself may make the mask stiffer or may make it more difficult to achieve exactly the desired flexibility.

It is an object of the present invention to provide an alternative mask and method of manufacture.

According to one aspect of the present invention there is provided a mask comprising a soft cuff member of substantially annular shape and a more rigid mount member of generally funnel shape, the cuff member being moulded with the mount member.

The cuff member is preferably formed by rotational moulding. The cuff member and mount member may be moulded integrally as a single piece or the mount may be pre-formed and the cuff member subsequently moulded with the mount member. The cuff member is preferably hollow. The mask may be a laryngeal mask, the cuff member being adapted to seal with tissue in the region of the hypopharynx. Alternatively, the mask may be a face mask, the cuff member being adapted to seal around the nose and mouth.

According to another aspect of the present invention, there is provided a method of making a mask comprising the steps of adding a fluid plastics material to a mould having a first region defining the shape of a cuff and a second region defining the shape of a mount, angularly displacing the mould so that the fluid plastics material coats the first region to form a thin layer of gelled plastics in said region, angularly orienting the mould so that the fluid plastics material coats the second region to form a thicker layer in said second region, and subsequently removing from the mould a mask with an integral cuff and mount member.

According to a third aspect of the present invention there is provided a method of making a mask comprising the steps of pre-forming a mount member, placing the mount

member in a rotational mould and moulding a cuff member with the mount member by rotational moulding.

According to a further aspect of the present invention there is provided a mask made by a method according to the above other or third aspect of the invention.

A laryngeal mask assembly and face mask assembly according to the present invention, will now be described, by way of example, with reference to the accompanying drawings, in which:

- Figure 1 is a partly-sectional side elevation view of the laryngeal mask assembly;
- Figure 2 is a schematic sectional side elevation view of moulding apparatus used to form the mask of the assembly of Figure 1 at a first stage in the moulding operation;
- Figure 3 is a sectional side elevation view of the moulding apparatus of Figure 2 at a subsequent stage in the moulding operation;
- Figure 4 is a sectional side elevation view of a face mask;
- Figure 5 is a sectional, perspective view of the mould used to make the face mask of Figure 4; and

Figure 6 shows the underside of the cone of the face mask at a preliminary stage of manufacture.

With reference first to Figure 1, the laryngeal mask assembly comprises a tube 1 and a mask 2 mounted at the patient end 10 of the tube.

The tube 1 is of a bendable plastics material, such as PVC and is curved along its length. A bore 11 extends along the tube 1 from its patient end 10 to its rear, machine end 12. A small-bore inflation line 13 extends along the length of the tube 1, within a channel 14 formed along the outside of its wall, such as in the manner described in PCT/GB00/03044. Towards its machine end, the inflation line 13 extends away from the tube 1 and is connected to a combined valve and coupling 15 of the usual kind.

The mask 2 comprises a mount 20 and an inflatable cuff 21. The mount 20 is of a plastics material and is generally of a shoe or funnel shape. It has a relatively thick wall so that it is relatively stiff. The rear, machine end of the mount 20 has a neck 22 of circular section embracing and bonded to the patient end 10 of the tube 1. A silicone gasket (not shown) may be inserted between the tube 1 and the mount 20 to improve the seal. The mount 20 tapers outwardly from the machine end 22 to its patient end 23, which is inclined to the axis of the machine end at an angle θ of about 25° so that the patient end of the mount has an oval shape with its forward end 24 being more pointed than its rear end 25. The patient end 23 of the mount 20 is inclined to face towards the inner side of the curve of the tube 1.

Internally, the machine end 22 of the mount 20 communicates with a cavity 26 in the mount that increases in cross-sectional area along its length, from the machine end.

The cuff 21 is formed integrally as a single piece with the mount 20 and is of the same plastics material but has a thinner wall so that it is softer and more flexible. The cuff 21 is formed into an annulus of the same shape as the patient end 23 of the mount 20 and is oval with its forwardly-directed end 27 being more pointed than its rearwardly-directed end 28. The cuff 21 encloses a central region 29 of the same shape as the patient end 23 of the mount 20. The inflation line 13 extends beyond the patient end 10 of the tube, is moulded into the mount 20 and projects into the cuff 21 so that the cuff can be inflated and deflated via the inflation line. When inflated in position in a patient, the cuff 21 expands to contact patient tissue in the region of the hypopharynx.

The cuff 21 and mount 20 are formed using rotational moulding apparatus shown in Figures 2 and 3. The apparatus includes a mould 30 in two parts: an upper part 31 and a lower part 32, which can be separated after use to enable the component to be removed. Around the upper surface 33 of the lower part 32 extends an annular channel 34 the wall of which corresponds to the external shape of the cuff 21. The lower surface of the upper part 31 of the mould has a recess 35 of approximately funnel shape, the wall of which corresponds to the external shape of the mount 20. Additionally, the upper part 31 has a groove 36 in which is clipped the patient end of the inflation line 13. The inflation line 13 projects a short distance beyond the patient end of the groove 36, into the channel 34. A PTFE-coated wire, or a solid PTFE rod (not shown) is inserted in the line 13 during moulding, to prevent occlusion, and is

subsequently removed. The moulding apparatus additionally includes a conventional heater 40 and displacement means 41 for altering the orientation of the mould 30 as desired.

Initially, the mould 30 is oriented as shown in Figure 2, with the upper part 31 uppermost. A measured volume of plastisol 37, or other heat-gellable plastics in fluid form, is added to the mould 30 through an inlet passage, not shown, so that the plastics flows into the channel 34 in the lower part 32. The plastics is preferably in liquid form but could be in other fluid form, such as a powder. The mould 30 is then rocked about the x-axis 42 and the z-axis 43 so that the plastisol comes into contact with the entire surface of the channel 34. The mould 30 is heated by the heater 40 so that the plastisol 37 gels where it contacts the surface of the mould. This rocking movement is relatively brief so that the layer of plastics material built up on the surface of the channel 34 is only thin and, in particular, is of the appropriate thickness to provide the necessary flexibility of the cuff 21. It can be seen that the plastics deposited on the surface of the channel 34 provides a hollow, tubular formation of annular shape.

After the desired thickness of plastics has been laid down on the surface of the channel 34, the moulding apparatus moves to a second phase in which the mould 30 is rotated about the z-axis 43 by about 90°, as shown in Figure 3. When this happens, the remaining plastisol 37 runs out of the channel 34 and into one side of the funnel-shape recess 35. The quantity of plastisol deposited on the wall of the channel 34 is small compared with the total volume, so the majority of the plastisol is still liquid in the second phase. The mould 30 is gradually rotated and rocked about the x-axis 42 and the z-axis 43 so that the plastisol 37 is deposited on the wall of the recess 35. This process takes longer than that used to form the

cuff 21, because the desired wall thickness of the mount portion 20 is substantially greater than that of the cuff. Typically, the wall of the mount 20 would have a thickness of several millimetres, whereas the wall of the cuff 21 would only be a fraction of a millimetre. The quantity of plastisol used is preferably such that when the desired wall thickness of the mount 20 has been deposited, all the plastisol has been gelled. During either of these rotational moulding movements it may be necessary also to rotate or rock the mould 30 about the y-axis. The inflation line 13 extending along the groove 36 becomes embedded within the thickness of the wall of deposited plastics material. It may be necessary to block the patient end of the inflation line 13 with a removable insert, such as a wire, in order to prevent it becoming blocked by the plastics material. Instead of moulding the mask about the inflation line, the mask could be moulded with a small bore, such as by means of a wire core pin within the mould. One end of the bore would extend to the machine end of the mask and the other end would open inside the cuff. The bore could make connection with an inflation line extending within the wall of the tube.

When all the plastisol has gelled, the mould 30 is heat treated in the usual way fully to cure the plastics. The mould 30 is then separated into its two parts 31 and 32 and the mask 2 is removed. After removal of any sprue or excess plastic, the mask 2 is joined to the tube 1 in the usual way, with the inflation line 13 being clipped into the channel 14. The cuff 21 can then be inflated or deflated as desired via the inflation line 13.

In practice, the moulding apparatus would have several moulds mounted on a conveyor, turntable or the like, which pass through various stations at which the plastisol is

added, the mould is oriented as appropriate, the mould is heat treated, and the finished component is removed.

Forming the cuff and mount integrally according to the present invention, brings several advantages. It saves an additional assembly step of joining the cuff to the mount and thereby considerably reduces overall assembly costs of the complete laryngeal mask. It also improves the integrity of the mask and reduces the risk of separation of the cuff from the mount during use. By avoiding a separate join, the need for inspection and testing of a join is obviated.

It is not essential for the mount and cuff to be formed integrally since advantages can also be achieved where the mount is pre-formed and the cuff is subsequently moulded with the mount. This still achieves simplification of manufacture and enhanced integrity of the join between cuff and mount. If the mount or cone needs to be clear and transparent, such as in face masks where it is important to be able to see the patient's mouth region, rotational moulding may not be suitable because this technique cannot yet produce the necessary transparency. Rotational moulding is still, however, a desirable technique for forming the cuff of the mask. Whereas in previous face masks, where both the mount/cone and cuff are preformed and subsequently bonded together, the present invention is to mould the cuff directly onto the pre-formed mount/cone so that the moulding operation itself produces the bond between the cuff and the cone.

With reference to Figure 4, there is shown a face mask 50 comprising an upper mount member or cone 51 and a lower cuff 52. The cone 51 has a main body 53 of domed shape

with a short tubular connector 54 at its upper end and a narrow outwardly-projecting flange 55 at its lower end, which is oval in shape. The cone 51 is of a clear, transparent plastics material, typically PVC, and is made by an injection-moulding technique, or by some other technique that achieves the necessary transparency. The cuff 52 is a hollow, inflatable tubular balloon having an inflation inlet 56 extending through the flange 55 of the cone 51. The cuff 52 is shaped to seal around the nose and mouth.

With reference now also to Figure 5, the pre-formed cone 51 is placed in a rotational mould 60 comprising an upper part 61 of a heat-insulating material, such as PTFE, and a lower part 62 of a metal, such as aluminium. The upper part 61 has a large aperture 63 in which the main part of the cone 51 is located, there being a clearance between the outside of the cone and the inside of the aperture. The lower part 62 of the mould has an annular recess 64 in its upper surface 65 of the same oval shape as the lower edge of the cone 51. In section, the recess 64 defines the shape of the uninflated cuff 52. Two insulating gaskets 66 and 67 of a low durometer silicone are secured to the upper surface of the mould part 62, around the inside and outside respectively of the recess 64.

Initially, a measured quantity of plastisol 68, or similar material is poured in the recess 64 in the lower part 62 of the mould 60. The cone 51 is then placed on the lower part 62 of the mould with the flange 55 extending around the opening of the recess 64 and sitting on the inner and outer gaskets 66 and 67. The lower surface of the flange 55 is shown in Figure 6, where it can be seen that it has positioning tabs 69 and ribs 70 that engage in corresponding recesses (not shown) in the upper surface 65 of the lower part 62 of the mould 60. The upper part 61 of the mould 60 is then hinged down so as to trap the flange 55

between the two parts. A pin 71 mounted in the upper part 61 of the mould 60 projects downwardly through a hole in the flange 55 a short distance into the recess 64. The entire mould 60 is then rotated in two directions so as to coat the surface of the recess 64 with the plastisol 68. The lower part 62 of the mould 60 is heated, such as with infra-red lamps, so as to gel the plastisol coated on the surface of the recess 64. The mould 60 is rotated in two directions and stops with the upper part 61 below the lower part 62. In this position, the plastisol 68 flows towards the cone flange 55 where it melts the ribs 70 and the lower surface of the flange, to bond securely with it. After appropriate curing, the two parts 61 and 62 of the mould are separated and the completed face mask 50 is removed. The inflation inlet 56 is subsequently inserted into and sealed with the hole made by the pin 70. This technique enables a hollow cuff to be made by rotational moulding and a cone to be made by a different method whilst avoiding manual assembly operations and ensuring a secure bond.

It will be appreciated that the cuff of a face mask, laryngeal mask or the like need not necessarily be hollow but could be of a foam.

CLAIMS

1. A mask comprising a soft cuff member of substantially annular shape and a more rigid mount member of generally funnel shape, wherein the cuff member is moulded with the mount member.
2. A mask according to Claim 1, wherein the cuff member is formed by rotational moulding.
3. A mask according to Claim 1 or 2, wherein the cuff member and mount member are moulded integrally as a single piece.
4. A mask according to Claim 1 or 2, wherein the mount member is pre-formed and the cuff member is subsequently moulded with the mount member.
5. A mask according to any one of the preceding claims, wherein the cuff member is hollow.
6. A mask according to any one of the preceding claims, wherein the mask is a laryngeal mask and the cuff member is adapted to seal with tissue in the region of the hypopharynx.
7. A mask according to any one of Claims 1 to 5, wherein the mask is a face mask and the cuff member is adapted to seal around the nose and mouth.

8. A laryngeal mask substantially as hereinbefore described with reference to Figures 1 to 3 of the accompanying drawings.
9. A face mask substantially as hereinbefore described with reference to Figures 4 to 6 of the accompanying drawings.
10. A method of making a mask comprising the steps of adding a fluid plastics material to a mould having a first region defining the shape of a cuff and a second region defining the shape of a mount, angularly displacing the mould so that the fluid plastics material coats the first region to form a thin layer of gelled plastics in said region, angularly orienting the mould so that the fluid plastics material coats the second region to form a thicker layer in said second region, and subsequently removing from the mould a mask with an integral cuff and mount member.
11. A method of making a mask comprising the steps of pre-forming a mount member, placing the mount member in a rotational mould and moulding a cuff member with the mount member by rotational moulding.
12. A method of making a laryngeal mask substantially as hereinbefore described with reference to Figures 1 to 3 of the accompanying drawings.
13. A method of making a face mask substantially as hereinbefore described with reference to Figures 4 to 6 of the accompanying drawings.

14. A mask made by a method according to any one of Claims 10 to 13.
15. Any novel and inventive feature or combination of features as hereinbefore described.



INVESTOR IN PEOPLE

Application No: GB 0102371.2

Examiner: Susan Chalmers (Mrs)

Claims searched: 1-14

Date of search: 5 July 2001

**Patents Act 1977
Search Report under Section 17**

Databases searched:

UK Patent Office collections, including GB, EP, WO & US patent specifications, in:

UK Cl (Ed.S): A5R: RGEX; A5T: TCT

Int Cl (Ed.7): A61M: 16/04, 16/06

Other: ONLINE: EPODOC, WPI, JAPIO

Documents considered to be relevant:

Category	Identity of document and relevant passage	Relevant to claims
X	GB 2334215 A (SMITHS) see especially Figures 3 and 9 & EP 0935971 A	1,3,5,6
X	GB 2330312 A (SMITHS) see especially Figure 1 and page 3 line 18 to page 4 line 7	1,4,6
X	WO 94/17848 A (BRAIN) see especially Figures 5-10 and page 12 line 25 to page 15 line 10 & US 5391248, US 5305305	1,3,5,6

X	Document indicating lack of novelty or inventive step	A	Document indicating technological background and/or state of the art.
Y	Document indicating lack of inventive step if combined with one or more other documents of same category.	P	Document published on or after the declared priority date but before the filing date of this invention.
		E	Patent document published on or after, but with priority date earlier than, the filing date of this application.
&	Member of the same patent family		