



US 20130255663A1

(19) **United States**

(12) **Patent Application Publication**
Cadima et al.

(10) **Pub. No.: US 2013/0255663 A1**

(43) **Pub. Date: Oct. 3, 2013**

(54) **HYBRID GAS SURFACE BURNER**

(52) **U.S. Cl.**
USPC 126/39 E

(76) Inventors: **Paul Bryan Cadima**, Prospect, KY (US); **Bai Han**, Louisville, KY (US)

(57) **ABSTRACT**

(21) Appl. No.: **13/437,153**

A gas burner assembly is provided for a cooking appliance. The gas burner assembly comprises an outer gas burner configured to provide an outer cooking flame; and an inner infrared burner configured to provide an inner cooking flame. A gas cooking appliance is also provided that comprises a cook-top surface; and a gas burner assembly that comprises an outer gas burner configured to provide an outer cooking flame; and an inner infrared burner configured to provide an inner cooking flame.

(22) Filed: **Apr. 2, 2012**

Publication Classification

(51) **Int. Cl.**
F24C 3/08 (2006.01)

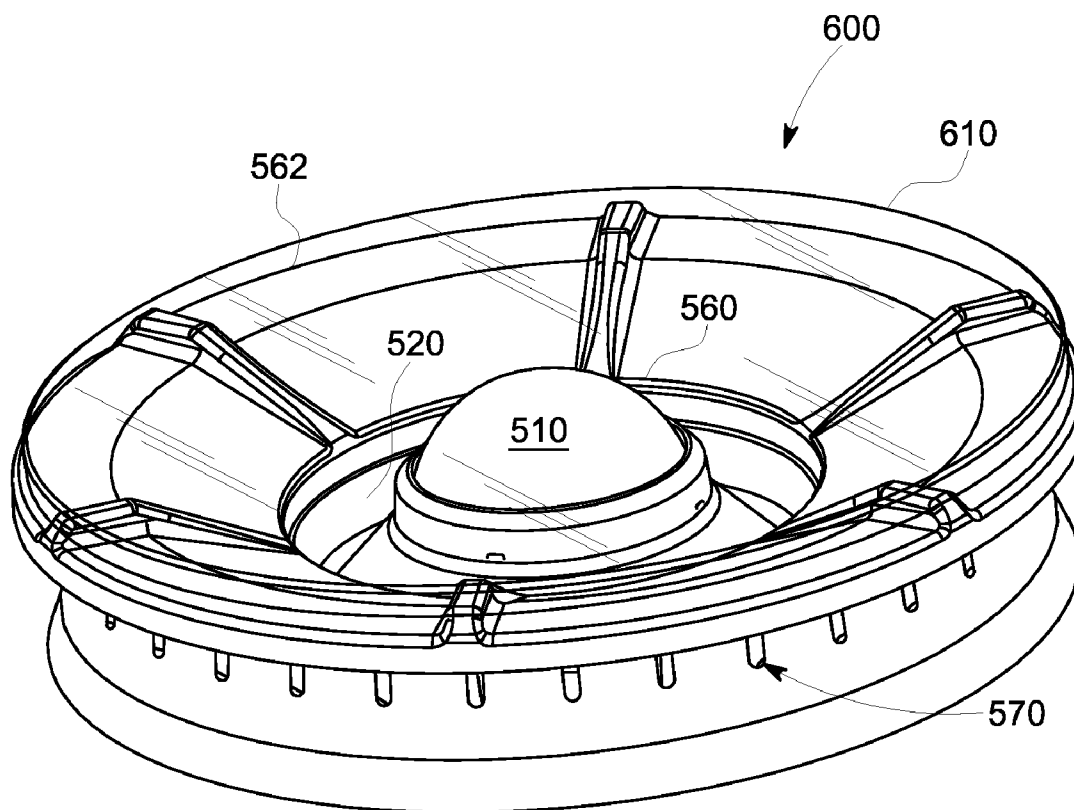

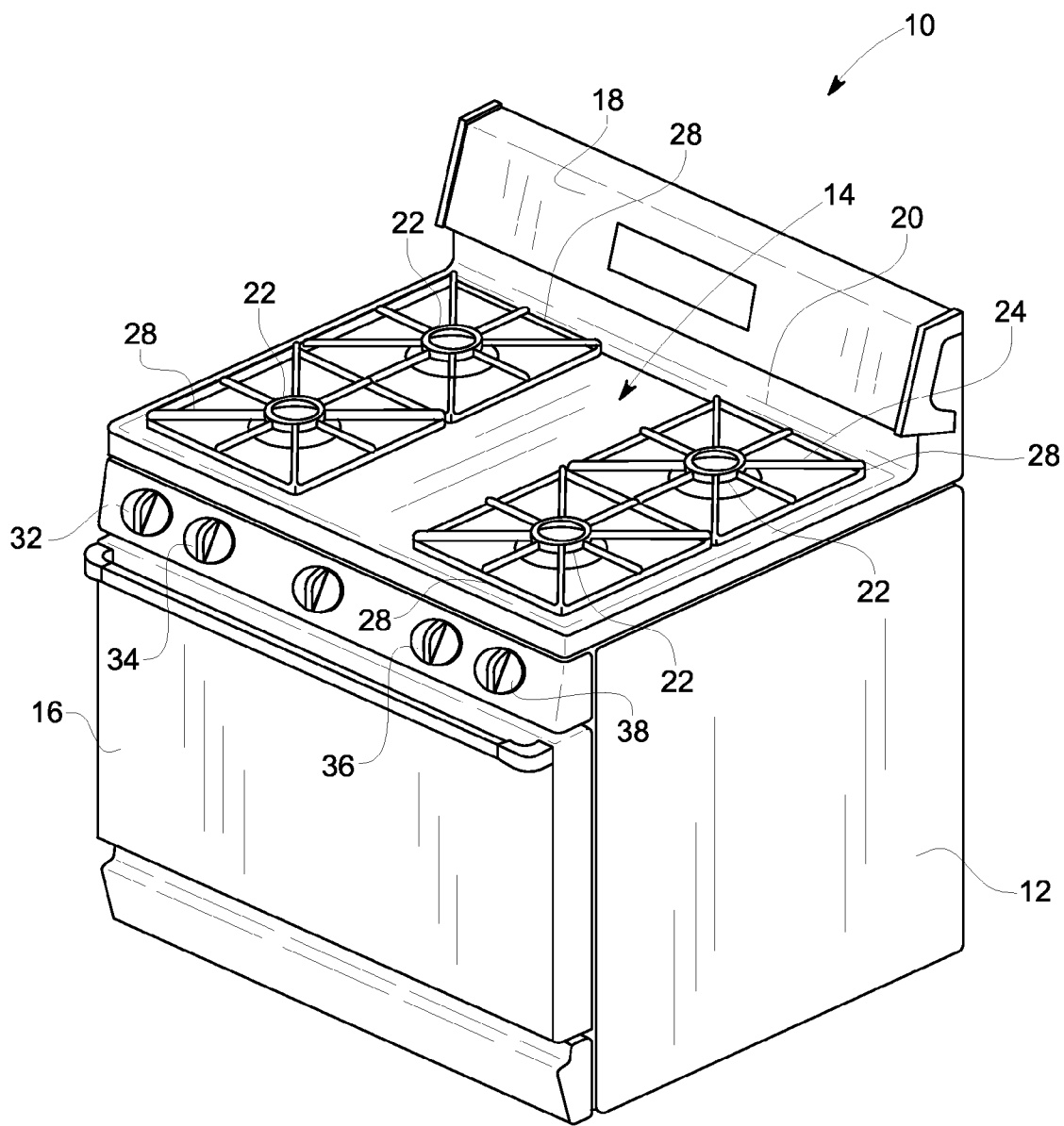

FIG. 1
PRIOR ART

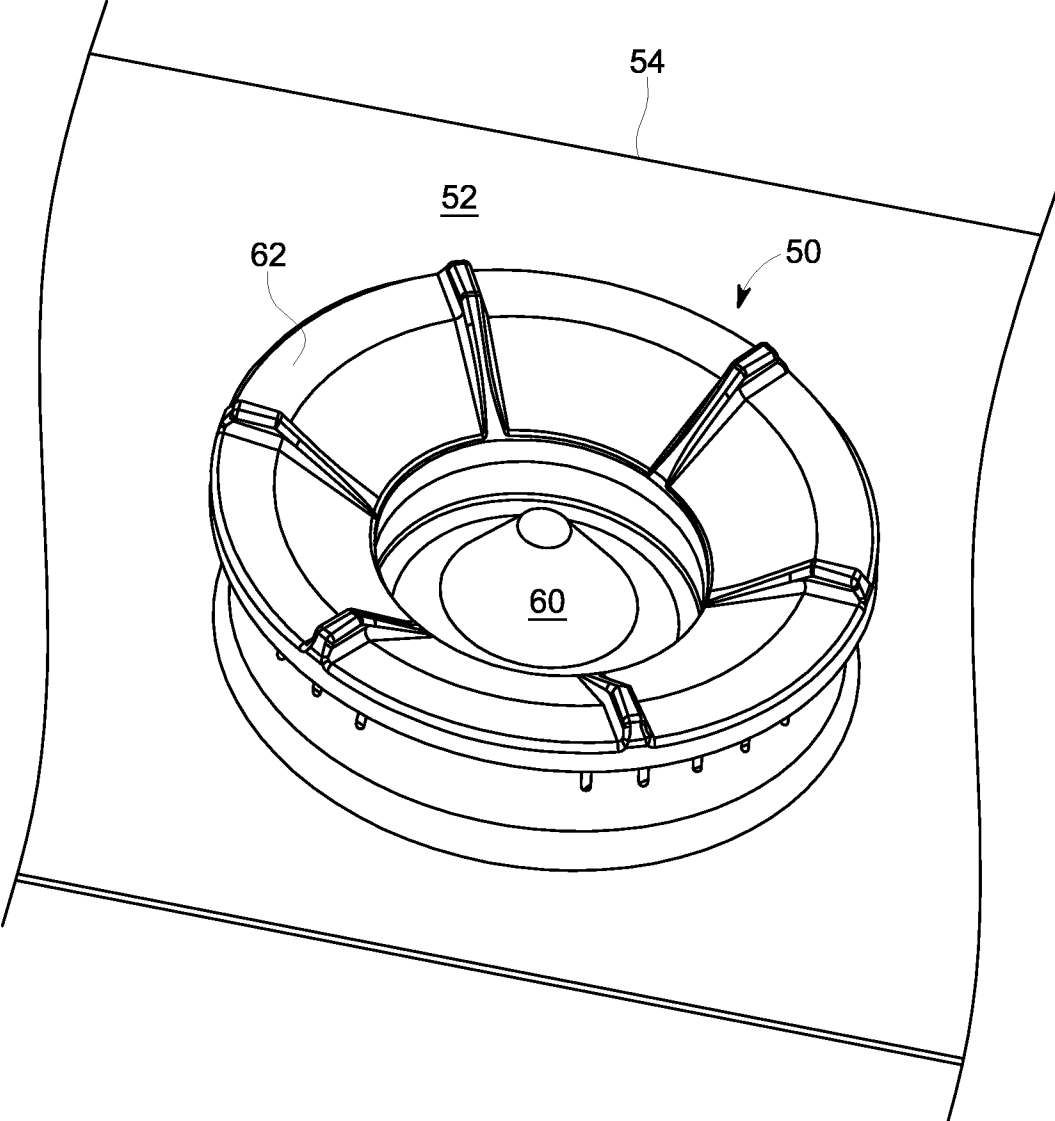

FIG. 2

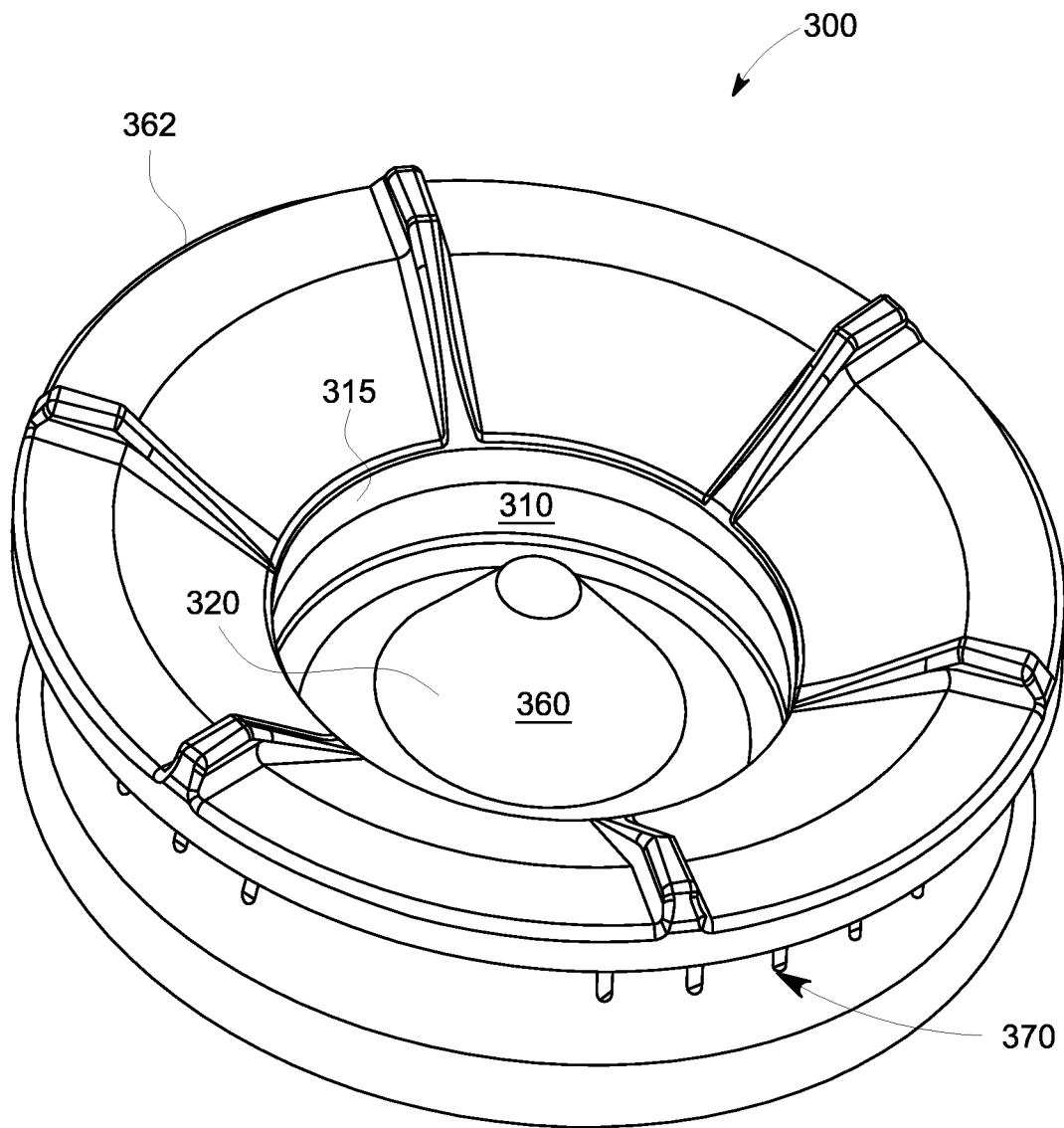

FIG. 3

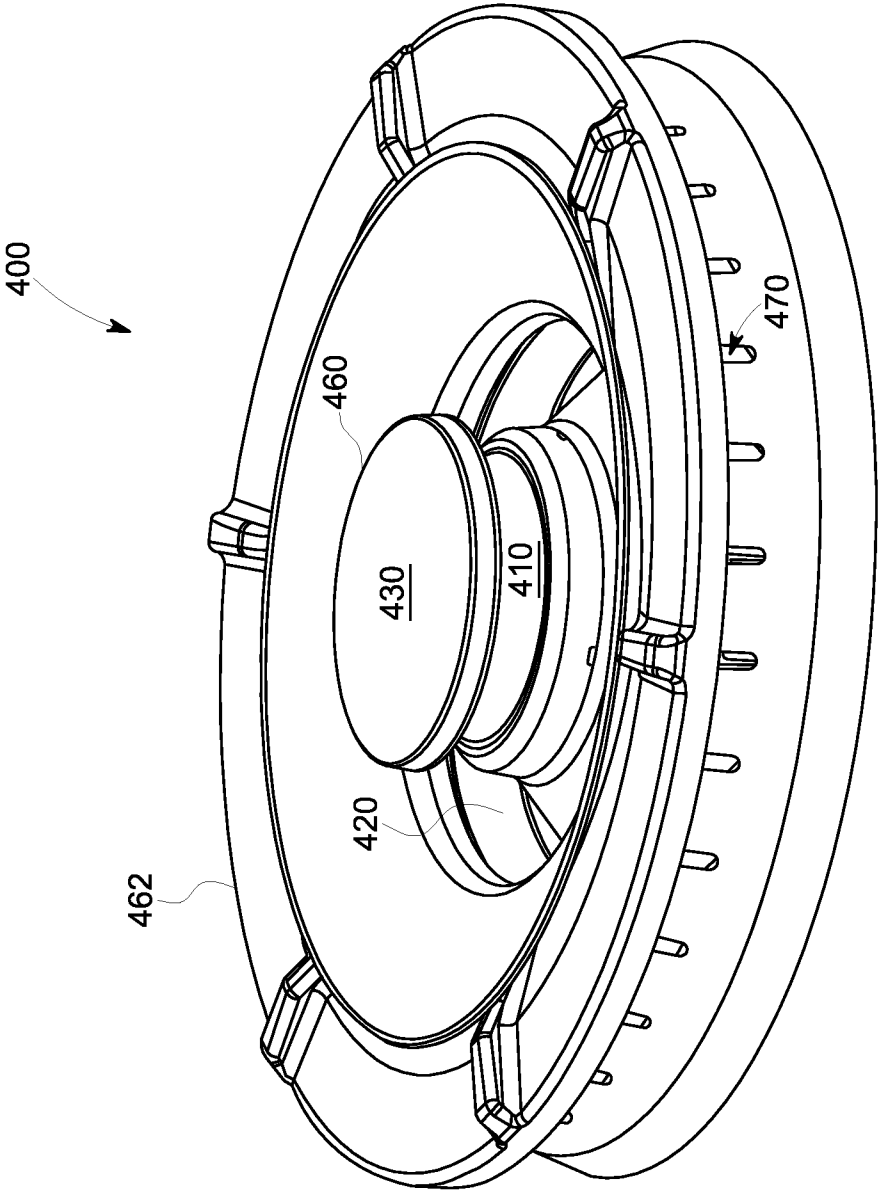

FIG. 4

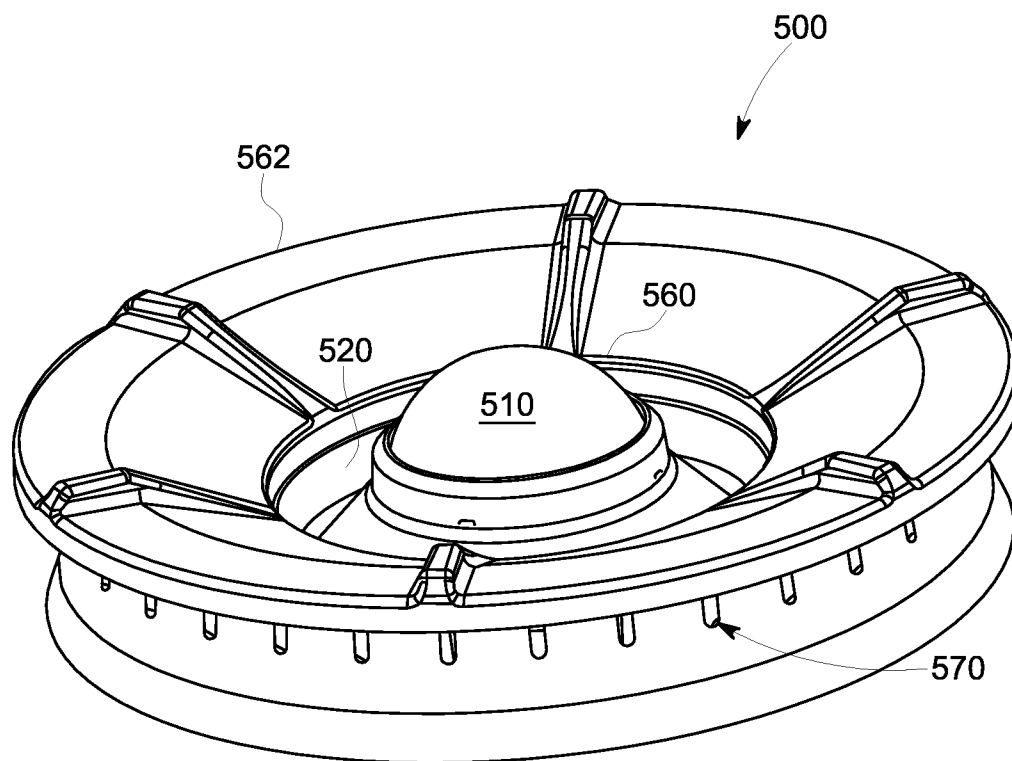

FIG. 5

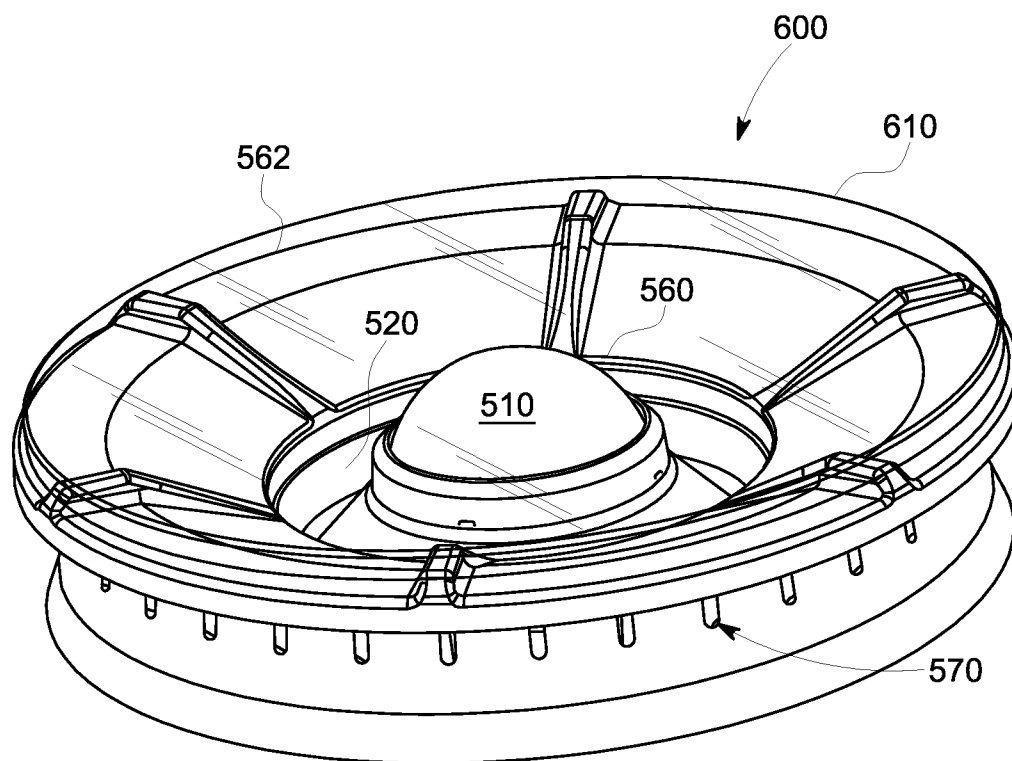

FIG. 6

HYBRID GAS SURFACE BURNER

BACKGROUND OF THE INVENTION

[0001] The subject matter disclosed herein relates to gas appliances, such as gas ranges, and more particularly, to multi-stage surface burners for use in such gas appliances.

[0002] For gas burners that are used as surface heating units in cooking appliances, such as ranges and cooktops, a high turndown ratio is generally desirable. A turndown ratio is a ratio of maximum output to minimum output. For a given burner, the maximum output typically signifies the “power” or “speed” of the burner and the minimum output is related to the simmer capability of a burner. The maximum output is limited by system gas flow handling capabilities and safety considerations. The minimum output is limited by the ability of the burner to maintain a stable flame under transient pressure fluctuations caused, for example, by air currents in the room, or sudden opening or closing of nearby cabinet doors or, if applicable, the oven door.

[0003] A number of techniques exist for improving the turndown ratio of gas burners. For example, multi-ring gas burner assemblies typically include at least an inner gas burner and an outer gas burner for collectively producing a plurality of rings of flame to heat a utensil supported thereon. Most multi-ring burners have multiple stages that can support flames on all rings simultaneously for a maximum output or can support flames on less-than-all rings for a lower output.

[0004] Typically, the smaller inner gas burner must be scaled down in size to support low output rates. Although the total output of the smaller inner burner may be relatively low, the heat is focused on a small area and thus the cookware directly above the inner burner may be heated too much locally above the inner burner while the average food load temperature is low (i.e., a gradient is present in the food load). The use of a diffuser over the inner burner has been proposed as a technique to help spread the heat, as well as spacing the inner burner further away from the cookware to increase diffusion of the heat with air. These techniques, however, impact the efficiency and performance of the burners when turned up to a high rate for a maximum output.

[0005] In addition, the center burner of existing multi-ring burners is a partially pre-mixed blue flame burner. Thus, secondary air must be supplied to the center burner in order for the center burner to burn the fuel completely. Thus, air gaps are required around the center burner to supply the air. These gaps are generally considered unsightly and make clean-up more difficult.

[0006] Infrared (IR) burners are generally more efficient than conventional gas burners and can heat more uniformly over a larger area. IR burners mix all of the needed air into the gas before the mixture exits the burner. The mixture exiting the IR burner burns quickly due to the high amount of air contained therein. Accordingly, IR burners include small holes from which the gas escapes quickly in order to keep the mixture from burning back into the burner.

[0007] As such, a primary difference between normal blue flame burners and IR burners is that the flame length of an IR burner is shorter than that of a normal blue flame burner, and much of the heat released during combustion is absorbed into the burner, causing the burner to glow hot and re-release the absorbed heat in the form of radiation instead of purely convective heat.

[0008] IR burners, however, suffer from a poor appearance, a lack of protection from spills, and they have a substantially

lower turn-down ratio. The typical turn-down ratio for an infrared burner is on the order of 3-to-1 versus a typical turn-down ratio of approximately 12-to-1 for a conventional single ring atmospheric burner. For this reason, IR burners are rarely used for cooktop surface burners.

[0009] Thus, a need remains for a cooktop burner that can evenly heat food loads when at the minimum setting while maintaining high rate performance. A need also remains for a top burner that is substantially sealed to the cooktop surface without the need for unsightly gaps to supply secondary air to the center burner.

BRIEF DESCRIPTION OF THE INVENTION

[0010] As described herein, the exemplary embodiments of the present invention overcome one or more disadvantages known in the art.

[0011] One aspect of the present invention relates to a gas burner assembly for a cooking appliance, the gas burner assembly comprising an outer gas burner configured to provide an outer cooking flame; and an inner infrared burner configured to provide an inner cooking flame.

[0012] Another aspect of the present invention relates to a gas cooking appliance, comprising: a cooktop surface; and a gas burner assembly. The gas burner assembly further comprises an outer gas burner configured to provide an outer cooking flame; and an inner infrared burner configured to provide an inner cooking flame.

[0013] Advantageously, illustrative embodiments of the present invention provide improved multi-stage burners. The disclosed multi-stage burners can heat food more evenly when at substantially minimum settings while maintaining high rate performance. Additionally, because IR burners mix the air in the fuel before the fuel burns, use of an IR burner for the center burner eliminates the need for gaps or spacing around the burner to supply air to the center, resulting in an improved appearance.

[0014] These and other aspects and advantages of the present invention will become apparent from the following detailed description considered in conjunction with the accompanying drawings. It is to be understood, however, that the drawings are designed solely for purposes of illustration and not as a definition of the limits of the invention, for which reference should be made to the appended claims. Moreover, the drawings are not necessarily drawn to scale and, unless otherwise indicated, they are merely intended to conceptually illustrate the structures and procedures described herein.

BRIEF DESCRIPTION OF THE DRAWINGS

[0015] In the drawings:

[0016] FIG. 1 illustrates an embodiment of an exemplary free-standing gas range;

[0017] FIG. 2 is an exemplary burner assembly applicable to the gas range shown in FIG. 1; and

[0018] FIGS. 3 through 6 illustrate various exemplary embodiments of the burner assembly of FIG. 2 in accordance with the present invention.

DETAILED DESCRIPTION OF THE EXEMPLARY EMBODIMENTS OF THE INVENTION

[0019] One or more illustrative embodiments of the invention will be described below in the context of a gas cooking appliance in the form of a gas range. However, it is to be

understood that embodiments of the invention are not intended to be limited to use with any particular gas appliance. Rather, one or more embodiments of the invention may be applied to and deployed in any other suitable environment in which it would be desirable to operate a gas fueled surface heating unit.

[0020] As illustratively used herein, the term “appliance” is intended to refer to a device or equipment designed to perform one or more specific functions. This may include, but is not limited to, equipment for consumer use, e.g., a gas range or a gas cooktop. This may include, but is not limited to, any equipment that is useable in household or commercial environments.

[0021] While the methods and apparatus are herein described in the context of a gas range, as set forth more fully below, it is contemplated that the herein described methods and apparatus may find utility in other applications, including, but not limited to gas cooktops, gas heater devices, gas ovens, gas kilns, gas-fired meat smoker devices, and gas barbecues. In addition, the principles and teachings set forth herein may find equal applicability to combustion burners for a variety of combustible fuels. The description below is therefore set forth only by way of illustration rather than limitation, and any intention to limit practice of the herein described methods and apparatus to any particular application is expressly disavowed.

[0022] FIG. 1 illustrates an exemplary free-standing gas range 10 in which the herein described apparatus and methods may be practiced. Range 10 includes an outer body or cabinet 12 that incorporates a generally rectangular cooktop 14. An oven, not shown, is positioned below cooktop 14 and has a front-opening access door 16. A range backsplash 18 extends upward from a rear edge 20 of cooktop 14 and contains various control selectors (not shown) for selecting operative features of heating elements for cooktop 14 and the oven.

[0023] Cooktop 14 includes four gas fueled burner assemblies 22 which are positioned in spaced apart pairs positioned adjacent each side of cooktop 14. Each burner assembly 22 extends upward through an opening in cooktop 14, and a grate 28 is positioned over each burner assembly 22. Each grate 28 includes a horizontally extending support structure thereon for supporting cooking vessels.

[0024] Cooktop 14 also includes control devices, such as, knobs 32, 34, 36, and 38 that are manipulated by a user to adjust the setting of a corresponding gas valve (not shown) to control the amount of heat output from the corresponding one of burner assemblies 22. For example, rotating knob 32 in one direction switches the valve from off to the full on position. Continued rotation gradually moves the valve from the full open position to the minimum setting position. Accordingly, the user may adjust the heat output of the corresponding burner to the desired level.

[0025] It is contemplated that the herein described apparatus and methods are applicable, not only to cooktops which form the upper portion of a range, such as range 10, but to other forms of cooktops as well, such as, but not limited to, cooktops that are mounted to a kitchen counter. Therefore, range 10 is provided by way of illustration rather than limitation, and accordingly there is no intention to limit application of the herein described apparatus and methods to any particular appliance or cooktop, such as range 10 or cooktop 14. It is also to be understood that there can be any other number of burner assemblies or any combination of burner

assemblies and other type of cooking surfaces, such as grills and hot plates, included in cooktop 14.

[0026] FIG. 2 is an exemplary burner assembly 50 applicable to gas range 10 shown in FIG. 1. Burner assembly 50 is mounted on a cooktop surface 52 of a cooktop 54, and includes an inner IR burner 60, and an outer gas burner 62 concentric with inner IR burner 60. A number of alternate embodiments of the inner IR burner 60 are discussed further below in conjunction with FIGS. 3 through 6. The particular embodiment of the burner assembly 50 shown in FIG. 2 corresponds to a first embodiment, the details of which are discussed further below in conjunction with FIG. 3. In the exemplary embodiment, cooktop 54 is fabricated from one of steel or glass. Alternatively, cooktop 54 is made of other suitable materials.

[0027] The exemplary gas surface burner 50 of FIG. 2 employs a hybrid approach to surface burners that seeks to take advantage of the benefits of both premixed and atmospheric partially premixed burners. As discussed further below, according to one aspect of the invention, the inner burner 60 is embodied as an IR burner (such as described herein). In the exemplary gas surface burner 50 of FIG. 2, the outer gas burner 62 is embodied as a burner which supports a partially premixed air/fuel flame on the outer ring of ports and the inner burner 60 is embodied as a burner which supports a fully premixed air/fuel IR flame. Among other benefits, the exemplary gas surface burner 50 of FIG. 2 realizes uniform heating at low firing rates. It is noted that at lower firing rates, the outer burner 62 is turned off and only the inner IR burner 60 remains on.

[0028] The present invention recognizes that radiant or IR burners, such as the inner burners 60, radiate a significant portion of their energy output in the infrared spectrum rather than heating by convection. Thus, a number of exemplary reflectors and/or radiators can optionally be employed to direct the heat uniformly to a broad area.

[0029] FIG. 3 illustrates a first exemplary embodiment 300 of the multi-ring burner assembly 50 of FIG. 2. In the exemplary burner assembly 300 of FIG. 3, the central simmer burner 360 is embodied as an annular IR ring 310 that emits IR energy inward towards a centrally located parabolic reflector 320. The exemplary annular IR ring 310 is substantially vertical, that is, it extends axially in a substantially vertical direction relative to the plane of the supporting surface, and can be fabricated, for example, using a stainless steel mesh. The parabolic reflector 320 can be fabricated, for example, using a ceramic material, stainless steel, or another high temperature alloy, such as Inconel™. The shape of the reflector 320 may be manipulated to control the heat flux to the cookware, as would be apparent to a person of ordinary skill in the art. The outer gas burner 362 includes a plurality of ports 370 to support traditional blue flames.

[0030] Among other benefits, an overhang 315 of the burner cap of the exemplary multi-ring burner assembly 300 of FIG. 3 substantially hides the unattractive IR porous medium of the annular IR ring 310 from sight.

[0031] FIG. 4 illustrates another exemplary embodiment 400 of the burner assembly 50 of FIG. 2. In the exemplary multi-ring burner assembly 400 of FIG. 4, the central simmer burner 460 is embodied as an annular IR ring 410 that emits IR energy (for example, heat) outward towards an outer, concentrically located reflector 420. The exemplary annular IR ring 410 is substantially vertical and can be fabricated, for example, using a stainless steel mesh. The reflector 420 can

be fabricated, for example, using a ceramic material, stainless steel, or another high temperature alloy, such as Inconel™. The shape of the reflector **420** may be manipulated to control the heat flux to the cookware, as would be apparent to a person of ordinary skill in the art. The outer gas burner **462** includes a plurality of ports **470** to support traditional blue flames.

[0032] Among other benefits, the exemplary multi-ring burner assembly **400** of FIG. **4** substantially hides the unattractive IR porous medium of the annular IR ring **410** from sight by using an optional cap **430**.

[0033] FIG. **5** illustrates another exemplary embodiment **500** of a burner assembly **50** of FIG. **2**. In the exemplary burner assembly **500** of FIG. **5**, the inner burner **560** is embodied as a centrally positioned IR burner surface **510** that extends over the central region of the burner assembly in a configuration that realizes a substantially improved high rate performance. The IR surface **510** can be fabricated, for example, using a stainless steel mesh. An annular reflector **520** which is disposed outwardly of the central region covered by surface **510** can optionally be included to direct the heat, as discussed above. The reflector **520** can be fabricated, for example, using a ceramic material, stainless steel, or another high temperature alloy, such as Inconel™. The shape of the reflector **520** may be manipulated to control the heat flux to the cookware, as would be apparent to a person of ordinary skill in the art. The outer gas burner **562** includes a plurality of ports **570** to support traditional blue flames.

[0034] In one particular implementation of the exemplary embodiment **500** of FIG. **5**, the centrally positioned firing IR surface **510** has a substantial dome shape to increase diffusion of the heat to the cooking utensil. In this manner, the heat is better distributed. In this manner, the cookware directly above the inner burner **560** is heated more uniformly and the food load temperature gradient is improved.

[0035] FIG. **6** illustrates a fourth exemplary embodiment **600** of the burner assembly **50** of FIG. **2**. The fourth exemplary embodiment **600** of FIG. **6** recognizes that the heat in the embodiment of FIG. **5** would tend to be more focused at simmer rates. Thus, the fourth exemplary embodiment **600** of FIG. **6** adds a ceramic piece of glass **610** to the other elements of the embodiment of FIG. **5** to diffuse the heat. This glass piece **610** transmits much of the IR spectrum and diffuses the convective portion of the heat output while providing full protection from spills.

[0036] It is noted that the glass piece **610** of FIG. **6** may be added in a similar manner to each of the embodiments of the burner assembly **300**, **400**, **500**. The glass piece **610** can be fixedly or removably mounted to the burner assembly **300**, **400**, **500**.

[0037] For a more detailed discussion of a gas burner (for example, multi-ring gas burner) assembly employing blue flame burners for both the inner and outer burner, see, for example, United States Publication No. 2007/0154858, entitled "Gas Burner Assembly Including Inner and Outer Burners and Methods for Implementing Same," assigned to the assignee of the present invention and incorporated by reference herein.

[0038] Thus, while there have been shown and described and pointed out fundamental novel features of the invention as applied to exemplary embodiments thereof, it will be understood that various omissions and substitutions and changes in the form and details of the devices illustrated, and in their operation, may be made by those skilled in the art without departing from the spirit of the invention. Moreover,

it is expressly intended that all combinations of those elements and/or method steps which perform substantially the same function in substantially the same way to achieve the same results are within the scope of the invention. Furthermore, it should be recognized that structures and/or elements and/or method steps shown and/or described in connection with any disclosed form or embodiment of the invention may be incorporated in any other disclosed or described or suggested form or embodiment as a general matter of design choice. It is the intention, therefore, to be limited only as indicated by the scope of the claims appended hereto.

What is claimed is:

1. A gas burner assembly for a cooking appliance, said gas burner assembly comprising:
 - an outer gas burner configured to provide an outer cooking flame; and
 - an inner infrared burner configured to provide an inner cooking flame.
2. The gas burner assembly of claim 1, wherein said inner infrared burner comprises an infrared ring and a reflector.
3. The gas burner assembly of claim 2, wherein said infrared ring comprises an annular ring that emits infrared energy inward toward said reflector.
4. The gas burner assembly of claim 2, wherein said infrared ring comprises an annular ring that emits infrared energy outward toward said reflector.
5. The gas burner assembly of claim 2, wherein said infrared ring comprises a stainless steel mesh material.
6. The gas burner assembly of claim 2, wherein said infrared ring is substantially vertical.
7. The gas burner assembly of claim 2, wherein said reflector comprises one or more of a ceramic material, stainless steel, and a high temperature alloy.
8. The gas burner assembly of claim 1, wherein said inner infrared burner comprises an infrared surface which extends over a central region of the assembly.
9. The gas burner assembly of claim 8, wherein said inner infrared surface comprises a substantially dome shaped surface.
10. The gas burner assembly of claim 1, further comprising a glass cover over said inner infrared burner.
11. The gas burner assembly of claim 1, wherein said outer gas burner and said inner infrared burner are substantially concentric.
12. A gas cooking appliance comprising:
 - a cooktop surface; and
 - a gas burner assembly comprising:
 - an outer gas burner configured to provide an outer cooking flame; and
 - an inner infrared burner configured to provide an inner cooking flame.
13. The gas cooking appliance of claim 12, wherein said inner infrared burner comprises a reflector and an infrared ring that emits infrared energy toward said reflector.
14. The gas cooking appliance of claim 13, wherein said infrared ring comprises an annular ring disposed outwardly of said reflector.
15. The gas cooking appliance of claim 13, wherein said infrared ring comprises an annular ring disposed inwardly of said reflector.
16. The gas cooking appliance of claim 13, wherein said infrared ring is substantially vertical.

17. The gas cooking appliance of claim 13, wherein said reflector comprises one or more of a ceramic material, stainless steel, and a high temperature alloy.

18. The gas cooking appliance of claim 12, wherein said inner infrared burner comprises a substantially dome-shaped infrared surface.

19. The gas cooking appliance of claim 12, further comprising a glass cover over said inner infrared burner.

20. The gas cooking appliance of claim 12, wherein said outer gas burner and said inner infrared burner are substantially concentric.

* * * * *