

Jan. 26, 1965

D. M. GRAHAM

3,167,218

SAFETY DESPENSING CAP

Filed Feb. 19, 1963

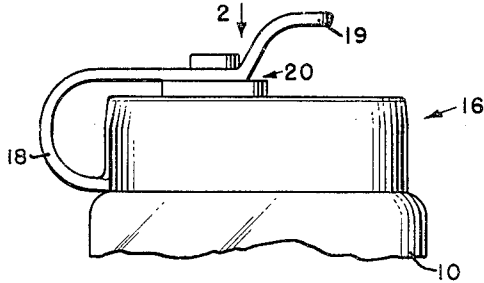

FIG. 1.

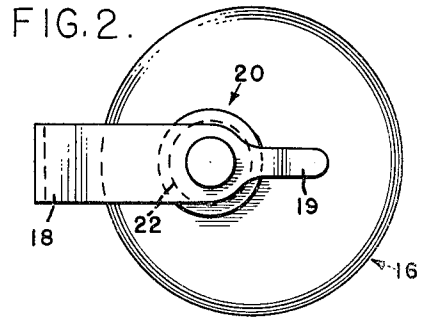

FIG. 2.

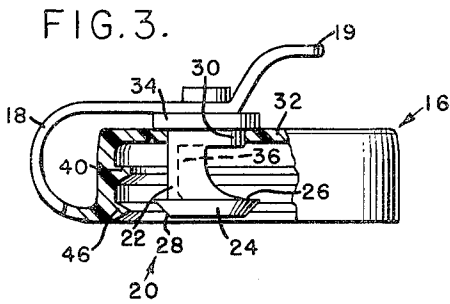

FIG. 3.

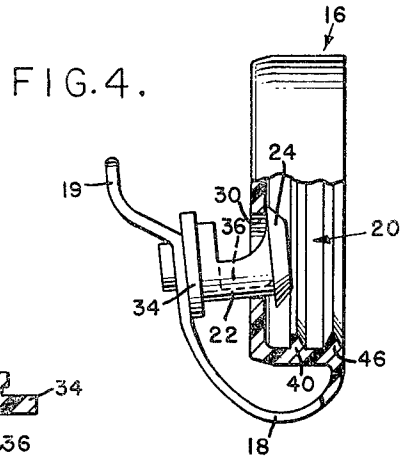

FIG. 4.

FIG. 5.

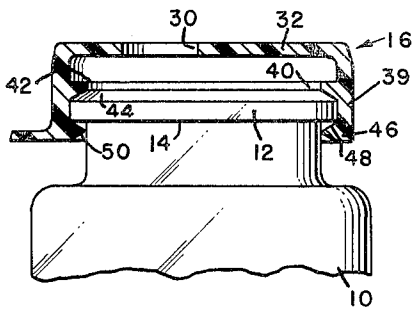
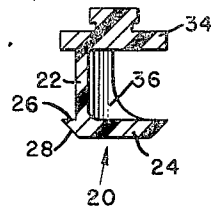

FIG. 6.

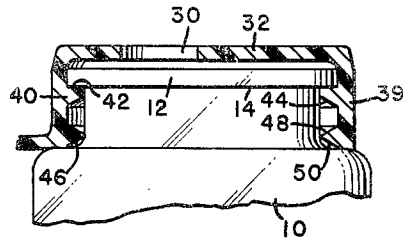

FIG. 7.

INVENTOR
DEAN M. GRAHAM
BY *Charles R. Poff*
att.

3,167,218
SAFETY DISPENSING CAP
 Dean M. Graham, % Graham Laboratories,
 North Blenheim, N.Y.
 Filed Feb. 19, 1963, Ser. No. 259,712
 4 Claims. (Cl. 222-361)

This invention relates to a new and improved safety dispensing cap particularly adapted to be applied to containers for tablets, pills, etc., and the principal object of the invention resides in the provision of a safety cap which cannot be removed once it is secured in position and which depends upon adult skill and intelligence rather than brute force in order to open the same for the dispensing of the contents thereof.

Another object of the invention resides in the provision of a dispensing means having a built-in time delay by which it is possible to abstract but a single tablet at each interval of a series of necessary manipulations well within the intelligence of an adult but ordinarily defeating a child wishing to get at the contents of the container.

A still further object of the invention resides in the provision of a selective dispenser device adapted to be used with caps of more ordinary construction, i.e., those which do not present the non-removable safety feature; the provision of a selective device which is integrally secured to or molded with the safety cap or ordinary cap; and the provision of a series of selector plugs of different capacities providing for a one-by-one selective abstraction of tablets of different sizes and shapes, this selector having a new and improved construction whereby it must be reclosed every time a tablet is abstracted, in order to obtain another tablet.

A still further object of the invention resides in the provision of a safety cap having a depending skirt with a pair of internal ridges therein, an inner and an outer ridge, the outer ridge being substantially at the edge of the skirt and being of a type of double bevel design, whereas the inner ridge spaced therefrom towards the bottom of the cap has an outwardly facing bevel but an inwardly facing square shoulder for cooperation with an outwardly extending square shoulder at the lip of the container to which it is to be applied, for the purpose of applying the cap originally at the factory by means of the beveled ridge so that the customer can easily remove the cap from the container, remove the cotton from the container, and replace the cap on the container, and then by pressing inwardly engage the square ridge in the interior of the cap with the square shoulder at the lip of the bottle, forming thereby a permanent lock which cannot be disrupted so that the cap cannot become detached but is permanently locked with respect to the container.

The invention further relates to arrangements and combinations of parts which will be hereinafter described and more particularly set forth in the appended claims.

Reference is to be had to the accompanying drawings, in which—

FIG. 1 is a view in elevation illustrating the invention;
 FIG. 2 is a plan view, looking in the direction of arrow 2 in FIG. 1;

FIG. 3 is a sectional view through the cap showing the selector closed;

FIG. 4 is a similar view showing the selector open;

FIG. 5 is a sectional view through the selector;

FIG. 6 is a sectional view of the cap illustrating the safety device and showing the cap applied in temporary relationship with respect to the container, and

FIG. 7 is a view similar to FIG. 6 but showing the

cap in its permanently locked condition with respect to the container.

Referring to the drawings, the container for the tablets, pills or other material is indicated by the reference numeral 10. This container can be of any usual kind except that as shown in FIGS. 6 and 7 it has a substantially square bead or lip 12 at the edge thereof rather than the usual rounded edge or pouring lip. Actually the configuration of this edge can be of any desired description except for the provision of a rather square edge or reentrantly formed shoulder underneath the same, this being indicated by the reference numeral 14 and the reason for this will be described hereinafter.

The cap itself indicated by the reference numeral 16 is of flexible material and in one form of the invention the cap may have integrally molded therewith a captive strap 18 for a selector which is generally indicated by the reference numeral 20. It will be made more clear hereinafter that the strap 18 is not necessary but it is useful providing for an inexpensive mode of manufacture of the device. The strap may have a fingerhold 19.

The selector 20 is best shown in FIGS. 3, 4 and 5 and comprises a semicylindrical plug 22. At the bottom end of this plug there is an outstanding generally circular enlargement 24 like a button which has a flat shoulder 26 at its upper edge and is undercut downwardly and inwardly about the periphery thereof as shown at 28. The enlargement 24 is slightly larger in diameter than an opening 30 in the top 32 of the cap 16, so that the plug can be snapped down through the opening by pressing on the head 34 at the opposite end of the plug body 22 from the enlargement 24. The head 34 prevents the plug from going any further into the cap than is shown in FIG. 3 and as shown in FIG. 4 the enlargement 24 prevents the selector from ever becoming dislodged from the cap.

The cylindrical portion 22 of the selector is provided with a lateral recess 36 and this recess is for the purpose of accommodating a single tablet receiving the same when the container 10 is shaken when the selector is in the inward position in FIG. 3. The plug is then retracted exposing the single tablet retained in the recess as shown in FIG. 4, so that the customer may abstract the same from the selector. It will be apparent that the strap 18 is not necessary, because once the selector is in position as described, it cannot be abstracted from the cap.

Referring now to FIGS. 6 and 7 which have omitted the selector for purposes of clarity of illustration of the following subject matter, the cap is shown as having the bottom 32 in which the opening 30 appears. The cap is shown as having two ridges therein on the depending skirt 39, these ridges being spaced, inwardly directed and annular. Spaced from the top 32 of the cap there is a first ridge indicated at 40, this ridge having a flat upper surface forming a flat, annular shoulder 42, and a beveled underneath edge conformation 44. The other ridge which is indicated at 46 has a beveled conformation both at the top and the bottom thereof as at 48, 50.

When the container is filled with tablets at the factory, there is usually placed on top of the tablets to prevent breakage a piece of wadding ordinarily of cotton or the like, and this of course has to be removed before the user can abstract any tablets from the bottle or container. Therefore at the factory the cap is merely applied to the square lip 12 of the container 10 by means of the outwardmost rib 46 which has both the upper and lower beveled continuous annular conformations 48 and 50. It will be seen therefore that it is fairly easy to apply the cap 16 to the square edge 12 and it is also equally easy to abstract it therefrom in order to remove the cotton wadding.

However, once the cotton wadding is removed, the cap

3

is adapted to be replaced on the container and by forcing the cap inwardly farther, the ridge at 40 snaps over the rear edge 12 due to beveled conformation 44 and the square lip 12 snaps behind the square shoulder 42 permanently locking the cap to the container as is illustrated in FIG. 7, and thus the square edge or shoulder 14 is locked with respect to the surface 42.

It will thus be seen that the objects of the invention are carried out. A safety cap is provided which can be manipulated by the customer to abstract the cotton from the container but is then capable of being forced to permanently lock the cap in place on the container so that no child is able to abstract tablets therefrom. No one can abstract tablets in bulk but has to get them out one at a time by the use of the selector as above described. Also as above explained, however, the selector may be utilized without the safety lock construction of the cap. When used together in the same device, there is provided a one piece safety cap which prevents bulk abstraction of the contents and ensures only a one-by-one or single abstraction of the contents and that only after a certain manipulation of the parts as would of course be provided in an instruction sheet with the container. Obviously a child's attention quotient would be exhausted long prior to getting out enough pills from the container to do him any damage and very small children of course would never be able to get any tablets out. Furthermore due to the manipulation required in order to get the tablets out one at a time, there is a time delay involved which would ordinarily allow a parent to reach a child and prevent him from abstracting even one tablet let alone several. The selector plug can be used with any cap having a corresponding hole therein to obtain the function of abstracting tablets one-by-one.

Having thus described my invention and the advantages thereof, I do not wish to be limited to the details herein disclosed, otherwise than as set forth in the claims, but what I claim is:

1. A dispenser cap for a container having means for securing the cap to the container, said cap comprising a top portion adapted to extend transversely across the top of the container when in assembled position, said top portion having an opening therein initially receiving a selector plug which extends inwardly below the top portion, said plug having an apertured tubular wall providing a

4

pocket adapted to receive a portion of the contents of the container, said plug having an enlarged head portion below the pocket of greater diameter than the opening and tapered downwardly and inwardly at its lower surface to permit it to initially pass through the opening in said top portion, but having a substantially flat upper surface engageable with the under surface of the top portion surrounding said opening therein to prevent subsequent removal of the plug from the cap, and having an upper stop member above the pocket and above the top portion of the cap to prevent the plug from completely passing downwardly through the cap.

2. A dispenser cap as defined in claim 1 wherein the selector plug is connected to the cap by means of a flexible strap.

3. A dispenser cap as defined in claim 2 wherein the strap is formed integral with the cap.

4. A dispenser cap as defined in claim 1 wherein the cap securing means comprises a sleeve depending from the top portion of the cap and having a pair of inwardly directed longitudinally spaced locking members adapted to coact with an outwardly directed rim carried by the container for respectively temporarily or permanently securing the cap to the container depending on which of the locking members is engaged with said container rim.

References Cited by the Examiner

UNITED STATES PATENTS

1,642,678	9/27	Horvath	222-344
2,542,350	2/51	Paulsen	220-60
2,688,422	9/54	Eisenberg	222-344
2,718,980	9/55	Strom	220-60
2,778,525	1/57	Lermer	220-60
2,805,801	9/57	Jacobs	222-545
2,838,211	6/58	Piker	222-543
2,851,203	9/58	Nowak	222-543
2,884,151	4/59	Biederman	220-38.5
3,025,988	3/62	Williams	215-41
3,069,040	12/62	Corsette	215-41
3,077,261	2/63	Tapper	206-42
3,113,693	12/63	Stull	220-60
3,116,857	1/64	Lehman	222-545

45 THERON E. CONDON, Primary Examiner.