



(12) **United States Design Patent**
Tyrrell et al.

(10) **Patent No.:** **US D833,974 S**
(45) **Date of Patent:** **** Nov. 20, 2018**

(54) **ELECTRIC BUSS RAIL CARRIER**
(71) Applicant: **IDEAL Industries, Inc.**, Sycamore, IL (US)
(72) Inventors: **James Tyrrell**, Sycamore, IL (US);
Justin Cerutti, Sycamore, IL (US)
(73) Assignee: **IDEAL Industries, Inc.**, Sycamore, IL (US)
(**) Term: **15 Years**

D689,206	S *	9/2013	Ellsworth	D25/125
D695,221	S *	12/2013	Lamouree	D13/122
D748,064	S *	1/2016	Baldwin	D13/155
D765,603	S *	9/2016	Baldwin	D13/155
D771,232	S *	11/2016	Coon	D23/393
D771,276	S *	11/2016	Walker	D25/119
D775,409	S *	12/2016	Klus	D26/138
D782,105	S *	3/2017	Klus	D26/138
D796,111	S *	8/2017	Trzcielinski	D26/142
D807,572	S *	1/2018	Klus	D26/138
9,912,100	B2 *	3/2018	Zantout	H01R 13/6205
D818,194	S *	5/2018	Trzesniowski	D26/138
2005/0237769	A1 *	10/2005	Hong	H01R 25/147
					362/648
2006/0039168	A1 *	2/2006	Mier-Langner	F21S 8/038
					362/648
2014/0167501	A1 *	6/2014	Marosi	G02B 6/0083
					307/11

(21) Appl. No.: **29/601,424**

(22) Filed: **Apr. 21, 2017**

(51) **LOC (11) Cl.** **13-03**

(52) **U.S. Cl.**
USPC **D13/139.2**

(58) **Field of Classification Search**
USPC D12/49, 50; D13/123, 128, 155, 129, D13/131, 132, 133, 153, 154, 156, 157, D13/184, 199, 139.2; D8/354, 356, 366, D8/380, 396, 373, 376, 307, 353, 352, D8/367, 378, 310; D25/119, 120, 121, D25/122, 123, 124, 125; D26/72, 138
CPC H02J 1/00; H01R 13/6205; H01R 13/627; H01R 24/62; H01R 25/147; H01R 25/16; H01R 25/14
See application file for complete search history.

(56) **References Cited**

U.S. PATENT DOCUMENTS

D85,226	S *	9/1931	Awbrey	D25/123
D175,586	S *	9/1955	Cataldo	D13/155
D278,229	S *	4/1985	Widell	D13/147
6,379,175	B1 *	4/2002	Reede	H01R 13/6463
					439/418
D489,465	S *	5/2004	Allsopp	D25/119
D649,691	S *	11/2011	Trzesniowski	D26/138

(Continued)

Primary Examiner — T Chase Nelson
Assistant Examiner — Ania Aman
(74) *Attorney, Agent, or Firm* — Greenberg Traurig, LLP

(57) **CLAIM**

The ornamental design for an electric buss rail carrier, as shown and described.

DESCRIPTION

FIG. 1 is a top, front perspective view of an electric buss rail carrier showing our new design;
FIG. 2 is a top plan view thereof;
FIG. 3 is a bottom plan view thereof;
FIG. 4 is a right side elevational view thereof;
FIG. 5 is a left side elevational view thereof;
FIG. 6 is a front side elevational view thereof; and,
FIG. 7 is a rear side elevational view thereof.
The electric buss rail carrier is shown with a symbolic break in its length. The appearance of any portion of the electric buss rail carrier between the break lines form no part of the claimed design.

1 Claim, 4 Drawing Sheets

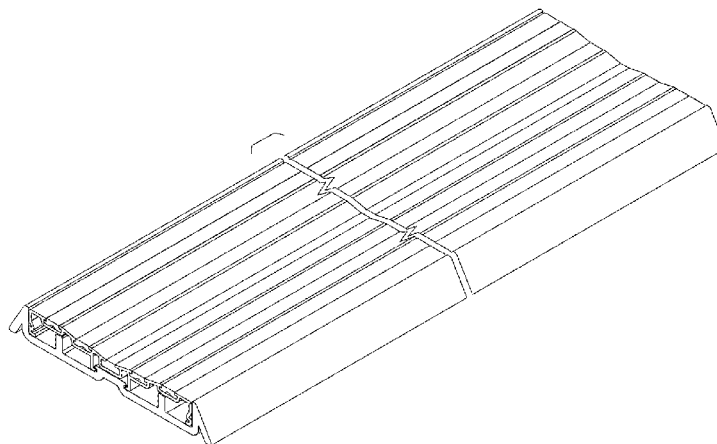

(56)

References Cited

U.S. PATENT DOCUMENTS

2015/0253360	A1*	9/2015	Wendt	H05B 37/0245
				307/18
2016/0268728	A1*	9/2016	Zantout	H01R 13/6205
2018/0090877	A1*	3/2018	Weiby	H01R 13/6205

* cited by examiner

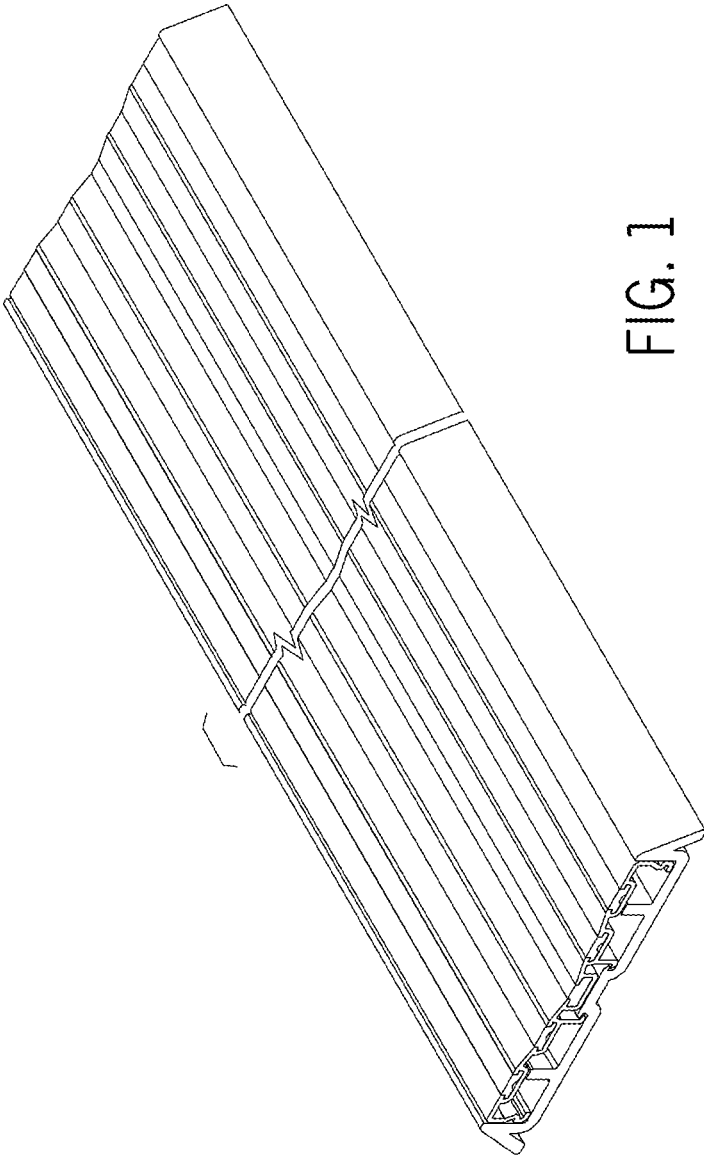

FIG. 1

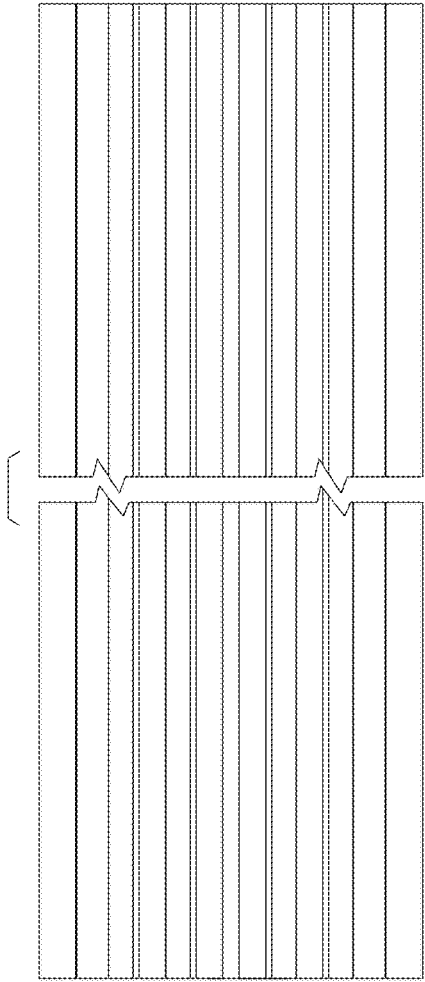

FIG. 2

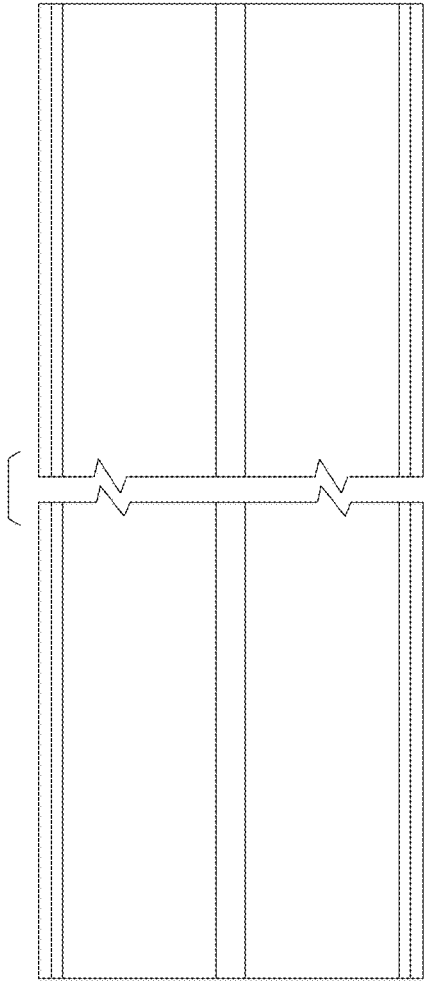

FIG. 3



FIG. 4

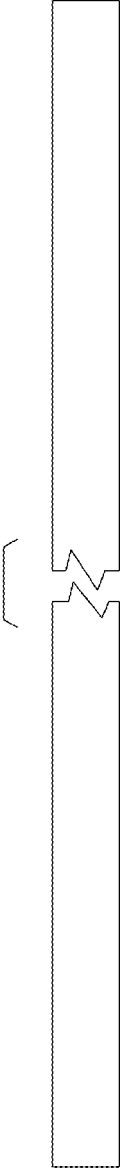

FIG. 5



FIG. 6



FIG. 7