



INTERNATIONAL APPLICATION PUBLISHED UNDER THE PATENT COOPERATION TREATY (PCT)

<p>(51) International Patent Classification ⁶ : A61B 17/22, A61M 25/00</p>	<p>A1</p>	<p>(11) International Publication Number: WO 98/38930 (43) International Publication Date: 11 September 1998 (11.09.98)</p>
<p>(21) International Application Number: PCT/US98/04417 (22) International Filing Date: 6 March 1998 (06.03.98) (30) Priority Data: 08/813,808 6 March 1997 (06.03.97) US 08/933,816 19 September 1997 (19.09.97) US (71) Applicant: PERCUSURGE, INC. [US/US]; 777 N. Pastoria Avenue, Sunnyvale, CA 94086 (US). (72) Inventors: ZADNO-AZIZI, Gholam-Reza; 8213 Del Monte Avenue, Newark, CA 94560 (US). PATEL, Mukund; 427 Ridgefarm Drive, San Jose, CA 95123 (US). MUNI, Ketan, P.; 97 Frontier Trail Drive, San Jose, CA 95136 (US). BAGAOISAN, Celso, J.; 4441 Pomponi Street, Union City, CA 94587 (US). (74) Agent: ALTMAN, Daniel, E.; Knobbe, Martens, Olson and Bear, LLP, 16th floor, 620 Newport Center Drive, Newport Beach, CA 92660 (US).</p>	<p>(81) Designated States: AL, AM, AT, AU, AZ, BA, BB, BG, BR, BY, CA, CH, CN, CU, CZ, DE, DK, EE, ES, FI, GB, GE, GH, GM, GW, HU, ID, IL, IS, JP, KE, KG, KP, KR, KZ, LC, LK, LR, LS, LT, LU, LV, MD, MG, MK, MN, MW, MX, NO, NZ, PL, PT, RO, RU, SD, SE, SG, SI, SK, SL, TJ, TM, TR, TT, UA, UG, UZ, VN, YU, ZW, ARIPO patent (GH, GM, KE, LS, MW, SD, SZ, UG, ZW), Eurasian patent (AM, AZ, BY, KG, KZ, MD, RU, TJ, TM), European patent (AT, BE, CH, DE, DK, ES, FI, FR, GB, GR, IE, IT, LU, MC, NL, PT, SE), OAPI patent (BF, BJ, CF, CG, CI, CM, GA, GN, ML, MR, NE, SN, TD, TG).</p> <p>Published <i>With international search report. Before the expiration of the time limit for amending the claims and to be republished in the event of the receipt of amendments.</i></p>	

(54) Title: CATHETER SYSTEM FOR CONTAINING AND REMOVING VASCULAR OCCLUSIONS

(57) Abstract

Intravascular catheters and a method for the treatment of a stenosis or an occlusion in a blood vessel. A main catheter (406) is first delivered to a site proximal to the occlusion (410). The main catheter (406) may include an occlusive device (408) at its distal end. An inner catheter or guidewire (420) having an occlusive device (422) at its distal end is delivered to the site of the occlusion (410), and the occlusive device (422) is activated at a site distal to the occlusion (410). A therapy catheter is then introduced to treat the occlusion (410). Next, an intermediate catheter (424) is delivered just proximal to the occlusive device (422), and the intermediate catheter (424) is used to aspirate the area removing particles and debris. Following the aspiration, the intermediate catheter (424) may be used to irrigate the area if desired. The aspiration and optional irrigation steps are preferably repeated until the particles and debris are removed. The catheter and method provide for minimally invasive devices and procedures which can be performed quickly and efficiently, with reduced risks to the patient.

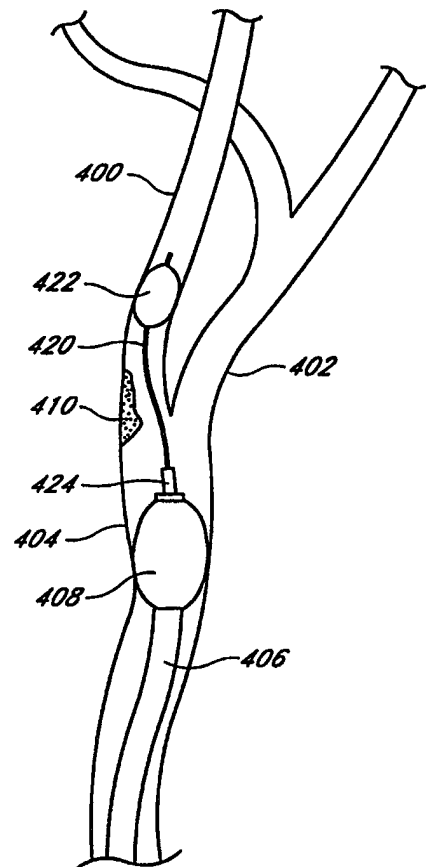

FOR THE PURPOSES OF INFORMATION ONLY

Codes used to identify States party to the PCT on the front pages of pamphlets publishing international applications under the PCT.

AL	Albania	ES	Spain	LS	Lesotho	SI	Slovenia
AM	Armenia	FI	Finland	LT	Lithuania	SK	Slovakia
AT	Austria	FR	France	LU	Luxembourg	SN	Senegal
AU	Australia	GA	Gabon	LV	Latvia	SZ	Swaziland
AZ	Azerbaijan	GB	United Kingdom	MC	Monaco	TD	Chad
BA	Bosnia and Herzegovina	GE	Georgia	MD	Republic of Moldova	TG	Togo
BB	Barbados	GH	Ghana	MG	Madagascar	TJ	Tajikistan
BE	Belgium	GN	Guinea	MK	The former Yugoslav Republic of Macedonia	TM	Turkmenistan
BF	Burkina Faso	GR	Greece	ML	Mali	TR	Turkey
BG	Bulgaria	HU	Hungary	MN	Mongolia	TT	Trinidad and Tobago
BJ	Benin	IE	Ireland	MR	Mauritania	UA	Ukraine
BR	Brazil	IL	Israel	MW	Malawi	UG	Uganda
BY	Belarus	IS	Iceland	MX	Mexico	US	United States of America
CA	Canada	IT	Italy	NE	Niger	UZ	Uzbekistan
CF	Central African Republic	JP	Japan	NL	Netherlands	VN	Viet Nam
CG	Congo	KE	Kenya	NO	Norway	YU	Yugoslavia
CH	Switzerland	KG	Kyrgyzstan	NZ	New Zealand	ZW	Zimbabwe
CI	Côte d'Ivoire	KP	Democratic People's Republic of Korea	PL	Poland		
CM	Cameroon	KR	Republic of Korea	PT	Portugal		
CN	China	KZ	Kazakstan	RO	Romania		
CU	Cuba	LC	Saint Lucia	RU	Russian Federation		
CZ	Czech Republic	LI	Liechtenstein	SD	Sudan		
DE	Germany	LK	Sri Lanka	SE	Sweden		
DK	Denmark	LR	Liberia	SG	Singapore		
EE	Estonia						

CATHETER SYSTEM FOR CONTAINING AND REMOVING VASCULAR OCCLUSIONS

Background of the Invention

Field of the Invention

5 The present invention relates to intravascular catheters and a method for containing and removing emboli, thrombi, plaque, and other types of particles and debris from the carotid arteries and other arteries above the aortic arch during diagnostic and therapeutic procedures.

Description of the Related Art

10 Human blood vessels often become occluded or completely blocked by plaque, thrombi, other deposits, emboli or other substances, which reduce the blood carrying capacity of the vessel. Should the blockage occur at a critical place in the circulatory system, serious and permanent injury, or even death, can occur. To prevent this, some form of medical intervention is usually performed when significant occlusion is detected.

15 The carotid arteries are the main vessels which supply blood to the brain and face. The common carotid artery leads upwards from the aortic arch, branching into the internal carotid artery which feeds the brain, and the external carotid artery which feeds the head and face. The carotid arteries are first narrowed and may eventually be almost completely blocked by plaque, and may further be complicated by the formation of thrombi (blood clots) on the roughened surfaces of the plaques. Narrowing or blockage of the carotid arteries is often untreatable and can result in devastating physical and cognitive debilitation, and even death.

20 Various types of intervention techniques have been developed which facilitate the reduction or removal of the blockage in the blood vessel, allowing increased blood flow through the vessel. One technique for treating stenosis or occlusion of a blood vessel is percutaneous balloon angioplasty. A balloon catheter is threaded through the patient's arterial system and inserted into the narrowed or blocked area, and the balloon is inflated to expand the constricted area. The fear of dislodging an embolus from an ulcerative plaque and the severe resulting consequences, however, has prevented the widespread use of angioplasty in the carotid arteries. Because of the potential complications, the options for minimally invasive treatment of the carotid arteries are severely limited.

25 Carotid endarterectomy is another type of intervention for removal of blockages from the carotid arteries. In endarterectomy, the carotid bifurcation is exposed through an incision in the neck of the patient. Clamps are placed on either side of the occlusion to isolate it, and an incision made to open the artery. The occlusion is removed, the isolated area irrigated and aspirated, and the artery sutured closed. The clamps are removed to reestablish blood flow through the artery. In carotid endarterectomy, the emboli and debris are contained and directed by activating and deactivating the clamps. For example, after the clamps are in place, one on the common carotid artery and one on the internal carotid artery, the particles are contained between the two clamps. After the occlusion is removed, the clamp on the common carotid artery is opened, allowing blood to flow into the previously isolated area toward the clamp on the internal carotid. This blood flow is then aspirated through an external aspiration tube. The common carotid artery is then reclamped, and the clamp on the internal carotid opened. This causes blood to flow into the previously isolated area toward the clamp on the common carotid artery. The flow

30

35

is then aspirated. The clamp on the internal carotid artery is closed, and the artery is sutured closed. This method allows for the flushing of debris into the area where aspiration occurs.

Alternatively, this method of clamping and unclamping the carotid arteries can be done after the incision in the artery is sutured closed. Using this method, it is hoped that any particles in the internal carotid artery will be forced back to the common carotid artery, then into the external carotid area, where serious complications are unlikely to arise from emboli.

Carotid endarterectomy is not without the serious risk of embolization and stroke caused by particles of the blocking material and other debris moving downstream to the brain, however. There is therefore a need for improved intravascular catheters and methods of treatment for occluded carotid arteries which decrease the risks to the patient.

Summary of the Invention

In a preferred embodiment, the catheters and method of the present invention provide for the removal of plaque, thrombi, emboli and other types of obstructions or occlusions from the carotid arteries and other blood vessels above the aortic arch. At least one catheter having an occlusive device such as a balloon or filter, a therapy catheter to treat the occlusion, and a source of aspiration to remove the debris created by the therapy are used. By utilizing the fluid pressure and flow within the blood vessel, the need for a separate irrigation catheter and irrigation fluid may be eliminated. Alternatively, irrigation fluid may be provided to flush the area. The catheters and method allow for the removal of occlusions more rapidly, and less invasively than known devices and methods. The minimally invasive treatment can be provided at low cost and at relatively low risk to the patient.

In accordance with one aspect of the present invention, there is provided a kit comprising a combination of a main catheter having an occlusive device, an inner catheter having an occlusive device, a therapy catheter, and an aspiration catheter. These catheters are all moveable relative to one another and independently manipulatable. In a preferred embodiment, the kit is used in a method for the treatment of an occlusion in a carotid artery. The inner catheter bearing an occlusive device preferably comprises an elongated tubular body, an inflatable balloon mounted on the distal end the tubular body, a core-wire joined to the distal end of the tubular body, and a coil member disposed about the core-wire. The aspiration catheter preferably comprises an elongate hollow shaft, a distal tip adapted for aspiration therethrough, and a proximal end adapted for connection with a source of negative pressure.

In accordance with another aspect of the present invention, there is provided a method for treatment of an occlusion in a carotid artery. A main catheter having a first occlusive device on its distal end is inserted into the artery, until the occlusive device is proximal to the occlusion. The first occlusive device is activated to occlude the artery proximal to the occlusion. An inner catheter having a second occlusive device on its distal end is inserted into the artery across the occlusion, until the occlusive device is distal to the occlusion. The second occlusive device is then activated to occlude the artery distal to the occlusion and create a working area surrounding the occlusion. By occlusive device is meant any device which is capable of preventing at least some particles or other debris from

migrating downstream. Examples of occlusive devices include inflatable balloons, filters or braids, or other mechanical devices.

5 A therapy catheter is then inserted into the working area and used to treat the occlusion. Appropriate treatment can include direct drug delivery to the site of the occlusion, angioplasty, cutting, scraping or pulverizing the occlusion, ablating the occlusion using ultrasound or a laser, deploying a stent within the artery, use of a thrombectomy or rheolitic device, or other treatments. Following treatment of the occlusion, the therapy catheter is removed. An aspiration catheter is then delivered to the working area, and the first occlusive device is deactivated to allow blood flow into the working area. Blood flow from collateral vessels prevent the movement of particles and debris downstream where they could cause serious complications. The blood flow also acts as irrigation fluid to create turbulence within the area. Aspiration of the working area is then performed to removed particles and debris. 10 Aspiration can occur simultaneously with the deactivating of the first occlusive device, if desired. Alternatively, either step can be performed first.

The method of the present invention preferably includes the steps of activating and deactivating the occlusive devices more than once. After the first occlusive device is deactivated to allow blood flow into the area, 15 the occlusive device is reactivated. The second occlusive device is then deactivated, to allow blood flow in from the distal end of the working area. The second occlusive device is reactivated, and these steps can be repeated any number of times until sufficient irrigation and aspiration of the working area occurs.

In another embodiment of the present invention, the method is performed within the two branches of the carotid artery. The first inner catheter with its occlusive device is delivered into one branch, while a second inner 20 catheter having a third occlusive device on its distal end is delivered into the other branch to occlude it. Aspiration then occurs in both branches of the artery to remove particles and debris.

In yet another embodiment of the present invention, aspiration occurs through the main catheter, and a separate aspiration catheter is not required. Following removal of the therapy catheter, and deactivation of the first occlusive device to allow blood flow into the working area, aspiration occurs through the distal end of the main 25 catheter. This eliminates the need to deliver a separate aspiration catheter, thus saving time which is critical in these types of procedures.

If desired, an irrigation catheter can be delivered into the working area following the removal of the therapy catheter. The irrigation catheter is used to deliver irrigation fluid to the working area. Aspiration then occurs through the distal end of the main catheter. In this case, anatomical irrigation (the use of the patient's own blood 30 flow for irrigation) as described above, is not used.

Yet another embodiment of the present invention incorporates the use of a single occlusive device. Using this method, a main catheter or guide catheter is first delivered into the carotid artery, with the distal end positioned just proximal to the occlusion. An inner catheter having an occlusive device on its distal end is then positioned with the occlusive device distal to the occlusion. The occlusive device is activated to occlude the artery distal to the 35 occlusion. A therapy catheter is delivered into the artery until it reaches the occlusion and therapy is performed to reduce or eliminate the occlusion. The therapy catheter is removed, and an intermediate catheter is delivered to a

position proximal to the occlusive device. Preferably, the distance between the proximal end of the occlusive device and the distal end of the intermediate catheter is narrowed at one point during aspiration to a distance of about 2 centimeters or less. The area just proximal to the occlusive device is aspirated, using the intermediate catheter, and then irrigated. The aspirating and irrigating steps can be repeated as often as necessary to facilitate the removal of particles and debris.

In another embodiment, the intermediate catheter has two or more lumens, such that aspiration and irrigation occur through different lumens within the same catheter. This prevents the possibility that aspirated particles will be flushed back into the patient when irrigation is begun.

In alternate embodiments of the present invention, two and even three occlusive devices are employed. In the case of two occlusive devices, a main or guide catheter with an occlusive device on its distal end is delivered to the common carotid artery and the occlusive device is activated. Next, an inner catheter with an occlusive device is delivered distal to the occlusion in the internal carotid artery and activated, thus isolating the occlusion between the two occlusive devices. Therapy is performed on the occlusion, followed by aspiration, and irrigation if desired.

In some cases, three occlusive devices are used. In this method, following activation of the occlusive device in the common carotid artery, an inner catheter with an occlusive device is delivered to the external carotid artery and the occlusive device activated. Next, a second inner catheter is delivered to the internal carotid artery past the site of the occlusion and the occlusive device activated to occlude the internal carotid artery. Alternatively, the first inner catheter and occlusive device is delivered to the internal carotid artery and activated, followed by delivery and activation of the second inner catheter and occlusive device in the external carotid artery. In either case, the occlusion is completely isolated between the three occlusive devices. This is followed by therapy on the occlusion and sequential aspiration and irrigation as desired.

Accordingly, the present invention provides for very fast and efficient treatment of an occlusion within a carotid artery. The patient's own blood can provide the irrigation fluid, thereby eliminating the need for a separate irrigation catheter and supply of irrigation fluid. By performing repeated activation and deactivation of the occlusive devices surrounding the working area, efficient clearance of the working area occurs. By reducing the number of devices needed to be inserted into the patient, the present invention reduces the amount of time required to complete the procedure, and allows the physician to restore normal blood flow in the vessel in a very short period of time. By performing a minimally invasive procedure, the risks and trauma to the patient are decreased, the costs of the procedure are lower, and the trauma and recovery time is greatly improved.

Brief Description of the Drawings

FIGURE 1 is a perspective drawing of the carotid arteries.

FIGURE 2 is a side view of a main catheter suitable for use in the present invention.

FIGURE 3 is a cross-sectional view of the main catheter taken along line 3-3 of FIGURE 2.

FIGURE 4 is a cross-sectional view of the main catheter taken along line 4-4 of FIGURE 2.

FIGURE 5 is a side view of the distal end of an inner catheter for use in the present invention.

FIGURE 6 is a partial cross-sectional view of the inner catheter taken along line 6-6 of FIGURE 5.

FIGURE 7 is a side view of an over-the-wire aspiration catheter for use in the present invention.

FIGURE 8 is a cross-sectional view of the over-the-wire aspiration catheter taken along line 8-8 in FIGURE 7.

FIGURE 9 is a cross-sectional view of the over-the-wire aspiration catheter taken along line 8-8 in FIGURE 7, showing a guidewire inserted there through.

FIGURE 10 is a side view of a single operator aspiration catheter for use in the present invention.

FIGURE 11 is a cross-sectional view of the single operator aspiration catheter taken along line 11-11 in FIGURE 10.

FIGURE 12 is a side view of an over-the-wire irrigation or aspiration catheter for use in the present invention.

FIGURE 13 is a side view of a single operator irrigation catheter for use in the present invention.

FIGURES 14 through 16A are cross-sectional views of the single operator irrigation catheter taken along lines 14-14, 15-15 and 16A-16A of FIGURE 13.

FIGURE 17 is a perspective view of one embodiment of the emboli containment and removal method of the present invention being performed within a carotid artery.

FIGURE 18 is a perspective view of another embodiment of the emboli containment and removal method of the present invention.

FIGURE 19 is a perspective view of yet another embodiment of the emboli containment and removal method which employs a single occlusive device.

FIGURE 20 is a perspective view of the emboli containment and removal method illustrated in FIGURE 19, showing the use of an intermediate catheter.

FIGURE 21 is a perspective view of still another embodiment of the emboli containment and removal method which employs two occlusive devices.

Detailed Description of the Preferred Embodiment

The present invention provides intravascular catheters and a method for containing and removing emboli, plaque, thrombi or other occlusions from a carotid artery and other arteries above the aortic arch. In a preferred embodiment, the catheters and method are used in the treatment of a stenosis or an occlusion in a carotid or other artery in which the stenosis or occlusion has a length and a width or thickness which at least partially occludes the vessel's lumen. Thus, the catheters and method are effective in treating both partial and substantially complete occlusions of arteries. It is to be understood that "occlusion" as used herein, includes both complete and partial occlusions, stenoses, emboli, thrombi, plaque, and any other substance which at least partially occludes the lumen of the artery.

As illustrated in FIGURE 1, the common carotid artery 10 is located in the neck and branches off into the internal carotid 12, and the external carotid 14 arteries. The internal carotid artery 12 supplies blood to the brain, while the external carotid artery 14 supplies blood to the head and face. In accordance with one aspect of the

present invention, a method will be described for the treatment of an occlusion within the internal carotid artery. It is to be understood that this method can be used on other arteries as well.

Generally, the method described involves the percutaneous treatment, containment and removal of occlusions within the carotid arteries or other arteries above the aortic arch. In one embodiment, a main catheter having an occlusive device on its distal end is first delivered to the common carotid artery, proximal to the site of the occlusion. It should be noted that, as used herein, "proximal" refers to the portion of the apparatus closest to the end which remains outside the patient's body, and "distal" refers to the portion closest to the end inserted into the patient's body. The occlusive device is activated to stop the downstream flow of blood. Collateral pressures from the Circle of Willis and other vessels keep the blood flow in the direction of the main catheter, preventing any emboli from moving downstream. In another embodiment, a main catheter without an occlusive device on its distal end, or a main catheter having an occlusive device which is not deployed, is delivered to the common carotid artery, proximal to the site of the occlusion.

In either case, an inner catheter having an occlusive device on its distal end is delivered through the main catheter and across the site of the occlusion. Alternatively, a detachable occlusive device can also be used in the present invention. In either case, the occlusive device is activated at a site distal to the occlusion.

In some cases, a second inner catheter is used to provide a third occlusive device. One inner catheter is delivered to the internal carotid artery, while the other inner catheter is delivered to the external carotid artery. When activated, the three occlusive devices completely isolate the area surrounding the occlusion to be treated.

A therapy catheter is then delivered to the site of the occlusion to treat the occlusion. Such treatment includes, but is not limited to, balloon angioplasty, thermal balloon angioplasty, delivery of an intravascular stent, atherectomy, or radiation treatment.

In one embodiment of the present invention, once therapy is complete, an irrigation catheter is delivered into the working area to provide irrigation fluid. Alternatively, anatomical irrigation can be used, as explained below. Aspiration of the area surrounding the treated occlusion is begun using either the main catheter or a separate aspiration catheter. Blood flow is allowed into the working area to be aspirated by deactivating the occlusive devices on the main and/or inner catheters. This helps to irrigate the area and ensure the removal of particles and debris from the artery.

In another embodiment of the present invention, the need for a separate irrigation catheter and irrigation fluid are eliminated. In the context of removing plaque, thrombi or other blockages from blood vessels, separate irrigation fluid is generally provided through an irrigation catheter to the site of treatment. It has been discovered that the patient's own blood can be used as irrigation fluid, without the need for delivery of a separate irrigation catheter and irrigation fluid.

Although the patient's own flow of blood can provide an irrigation source, situations sometime arise where providing separate irrigation fluid is desired. In such cases a separate catheter is introduced into the patient after the therapy catheter is removed and is delivered within close proximity to the occlusive device. Once the catheter is delivered proximal to the occlusive device, the area is first aspirated through the catheter. By delivering the

catheter close to the occlusive device a turbulence is created freeing debris from the edge of the occlusive device and other areas where it may be trapped. The debris is then aspirated from the patient. Following aspiration, irrigation fluid is provided if desired to flush any remaining particles and debris from the internal carotid.

Apparatus Used With the Present Invention

5 Main Catheter

To remove or reduce vascular occlusions, a main or guide catheter is first introduced into the patient's vasculature and can be used to guide the insertion of other catheters and devices to the desired site. In some embodiments of the present invention, the main catheter has an occlusive device on its distal end. The occlusive device can be an inflatable balloon, filter, expandable braid or other mechanical occlusive device. The occlusive device should be capable of preventing the migration of particles and debris from the working area, either through total or partial occlusion of the vessel. Note that the occlusion of the vessel need not be complete. Substantial occlusion of the vessel can be sufficient for purposes of the present invention. The catheter should be sized so as to slidably receive the inner, therapy and intermediate (irrigation and/or aspiration) catheters inserted therethrough.

FIGURE 2 illustrates a side view of a catheter which can be used as the outer or main catheter of the present system. Catheter 110 generally comprises an elongate flexible tubular body 116 extending between a proximal control end 112 and a distal functional end 114. The tubular body 116 has a main lumen 130 which extends between the ends 112 and 114. The main lumen 130 terminates in a proximal opening 123 and a distal opening 127. A smaller inflation lumen 132, configured in a side-by-side relationship with the main lumen 130, extends along the length of the tubular body 116, and terminates within an occlusion balloon 126 mounted on the distal end 114 of the catheter 110, as described below. The inflation lumen 132, illustrated in FIGURES 3 and 4, is in fluid communication with the occlusion balloon 126, such that fluid passing through the inflation lumen 132 may be used to inflate or deflate the balloon 126. The proximal end of the inflation lumen can terminate at one of the ports 122, 124 on the proximal end of the catheter 110.

A control manifold 119 is provided at the proximal end 112 of the catheter 110. The control manifold 119 is generally provided with a number of ports to provide access to the catheter lumen 130. For example, for the embodiment depicted in FIGURE 2, the control manifold 119 is provided with a catheter end-access port 122 and a catheter side-access port 124, to provide an introduction point for the insertion of other catheters into the lumen 130. Ports 122 and 124 are preferably provided with standard Touhy Borst connectors, although other types of connectors may be used. An inflation port 118, in fluid communication with the small inflation lumen 132, is further provided on the manifold 119 for attachment of devices to inflate or deflate the occlusion balloon 126. The manifold 119 is also provided with an irrigation/aspiration port 120 which is in fluid communication with the lumen 130, for attachment of devices to provide irrigation fluid or aspiration pressure. Other embodiments of the main catheter 110 may feature more or less ports, depending upon the number of lumen in the catheter and the desired functionalities of the catheter.

The manifold 119 is preferably formed out of hard polymers or metals, which possess the requisite structural integrity to provide a functional access port to the catheter lumen, such as for balloon inflation or delivery

of irrigation fluid and/or aspiration pressure. In one preferred embodiment, the manifold 119 is integrally formed out of polycarbonate. Of course, any suitable material may be used to form the manifold 119, including acrylonitrile butadiene styrene (ABS).

As illustrated in FIGURE 2, an inflatable balloon 126 is mounted on the distal end 114 of the catheter 110. The inflatable balloon 126 will function as an occlusion balloon, to prevent blood and debris from passing through the blood vessel distal to the balloon 126. Thus, the inflatable balloon 126 is preferably able to expand to fit a variety of different blood vessel diameters. Accordingly, it is preferred that the inflatable balloon 126 have a compliant expansion profile, tending to increase in radial diameter with increasing inflation pressure. To achieve this, the balloon 126 may be made out of materials which impart such expansion characteristics, including elastomeric materials such as latex or irradiated polyethylene. In one preferred embodiment, the inflatable balloon 126 is formed out of a material comprising a block copolymer of styrene-ethylene-butylene-styrene, sold under the trade name C-FLEX. Non-compliant balloons, such as those made from PET can also be used.

Alternatively, as illustrated in FIGURES 19-20, the main catheter 406 does not include a distal occlusive device, or the distal occlusive device on the main catheter is not used.

15 Inner Catheter

An inner catheter or guidewire having an occlusive device on its distal end is also used. The inner catheter is preferably made of metals such as stainless steel or nitinol, or plastics or composites. The occlusion removal can be effectively carried out using a number of guidewires or catheters that perform the function of occluding the vessel and allowing for the slidable insertion of various other catheters and devices. The term "catheter" as used herein is therefore intended to include both guidewires and catheters with these desired characteristics.

A preferred inner catheter for use in the present invention is illustrated in FIGURES 5 and 6. The catheter apparatus 310 is generally comprised of four communicating members including an elongated tubular member 314, an inflatable balloon member 316, a core-wire member 320 and a coil member 322. The catheter apparatus 310 is preferably provided with an outer coating of a lubricous material, such as TEFLON.

The body member 314 of the catheter apparatus 310 is in the form of hypotubing and is provided with proximal and distal ends 314A and 314B as well as an inner lumen 315 extending along the tubular member 314. The balloon member 316 is coaxially mounted on the distal end 314B of the tubular member 314 by suitable adhesives 319 at a proximal end 316A and a distal end 316B of the balloon member 316 as in the manner shown in FIGURE 6. The core-wire member 320 of the catheter 310 may be comprised of a flexible wire 320. The flexible wire 320 is joined by adhesives, soldering, brazing or crimping at a proximal end 320A of the flexible wire 320 to the distal end 314B of the tubular member 314 as in the manner shown in FIGURE 6.

Preferably, the proximal end 320A of the flexible wire 320 has a transverse cross sectional area substantially less than the smallest transverse cross-sectional area of the inner lumen 315 of the tubular member 314. In the preferred embodiment, the flexible wire 320 tapers in the distal end 320B to smaller diameters to provide greater flexibility to the flexible wire 320. However, the flexible wire may be in the form of a solid rod or a ribbon or combinations thereof.

As shown in FIGURE 6, the distal end 320B of the flexible wire 320 is secured to a rounded plug 318 of solder or braze at the distal end 322B of the coil member 322. The coil member 322 of the catheter 310 may be comprised of a helical coil 322. The coil member 322 is coaxially disposed about the flexible wire 320, and is secured to the flexible wire 320 by soldering, brazing or adhesives at about the proximal end 320A of the flexible wire 320 as in the manner shown in FIGURE 6.

The balloon member 316 is preferably a compliant balloon formed of a suitable elastic material such as a latex or the like, but can be made of non-compliant materials as well. The flexible coil 322 is preferably formed of a wire of platinum based alloys or gold. The flexible core-wire 320 and the tubular member 314 are preferably formed of a nickel-titanium alloy or stainless steel.

Once the inner catheter has been properly positioned inside the carotid artery at a point distal to the occlusion, the occlusive device at the distal end of the inner catheter is actuated to occlude the vessel distal to the existing occlusion to create a working area. When a detachable occlusive device is used, the occlusive device is positioned at a point distal to the occlusion to be treated, and activated to occlude the artery. It is to be understood that the stenosis or occlusion could be in a discrete location or diffused within the artery. Therefore, although placement of the occlusive device is said to be distal to the stenosis or occlusion to be treated, portions of the diffused stenosis or occlusion may remain distal to the occlusive device.

Therapy Catheter

After the area surrounding the occlusion has been isolated, a therapy catheter then is delivered to the site of the occlusion. The term "therapy catheter" is meant to include any of a number of known devices used to treat an occluded vessel. For example, a catheter carrying an inflatable balloon for use in balloon angioplasty can be delivered to dilate the occlusion. Thermal balloon angioplasty includes the use of heat to "mold" the vessel to the size and shape of the angioplasty balloon. Similarly, an intravascular stent can be delivered via a balloon catheter and deployed at the site of the occlusion to keep the vessel open. Cutting, shaving, scraping or pulverizing devices can be delivered to excise the occlusion in a procedure known as atherectomy. A laser or ultrasound device can also be delivered and used to ablate plaque in the vessel. Thrombectomy devices can be used, as can rheolytic devices, and devices which create a venturi effect within the artery. Various thrombolytic or other types of drugs can be delivered locally in high concentrations to the site of the occlusion. It is also possible to deliver various chemical substances or enzymes via a catheter to the site of the stenosis to dissolve the obstruction. The term "therapy catheter" encompasses these and similar devices.

Aspiration and Irrigation Catheters

After the therapy has been performed and the occlusion has been treated using any of the methods and apparatus described above, the working area is aspirated to remove fluid and debris. Aspiration can be provided through the main catheter if desired. A source of negative pressure is attached at the proximal end of the main catheter, and fluid and debris are aspirated through the main catheter's main lumen. Alternatively, an aspiration catheter or similar debris removing device can be delivered to the working area to remove particles and any other debris. The term "aspiration catheter" includes any device which creates an area of fluid turbulence and uses

negative pressure to aspirate fluid and debris, and includes thrombectomy catheters, rheolytic devices and those devices which create a venturi effect within the vessel. Thus, it is possible that a single catheter is used as both the therapy catheter and the aspiration catheter.

5 A preferred aspiration catheter is illustrated in FIGURE 7. The catheter 260 includes an adapter 262 and a seal at its proximal end. The catheter 260 further includes an aspiration port 264 to which a source of negative pressure is attached. The aspiration catheter further comprises a long hollow shaft 266 having a distal end 268. The distal tip 268 can include a radiopaque marker to aid in locating the tip 268 during insertion into the patient, and is preferably soft to prevent damage to the patient's vasculature.

10 The aspiration catheter illustrated in FIGURE 7 is an over-the-wire catheter. As seen in FIGURE 8, the catheter shaft 266 is hollow. During insertion of the aspiration catheter 260, the proximal end of a guidewire 270 is inserted into the distal end of the aspiration catheter 268, and the aspiration catheter 260 is slidably advanced over the guidewire 270, which is positioned inside the hollow lumen 272 of the aspiration catheter 260. The position of the guidewire 270 relative to the shaft 260 of the aspiration catheter 260 is illustrated in FIGURE 9, but of course, can vary. For this type of aspiration catheter 260, a very long guidewire 270, generally around 300 centimeters in length, is used to facilitate the insertion of the aspiration catheter 260 over the guidewire 270.

15 Alternatively, the aspiration catheter 280 can be of a single operator design, as illustrated in FIGURES 10-11. The catheter 280 has an adapter and an aspiration port at its proximal end. Like the over-the-wire aspiration catheter 260 the single operator aspiration catheter 280 further comprises a long hollow shaft 282 having a distal end 288. The distal tip 288 can include a radiopaque marker to aid in locating the tip 288 during insertion into the patient, and is preferably soft to prevent damage to the patient's vasculature. At the distal end of the shaft 288, a guidewire lumen 286 is attached. This lumen 286 provides a separate lumen, apart from the main aspiration lumen 284 of the catheter 280, for the insertion of the guidewire. This guidewire lumen 286 can be as short as 5 centimeters or longer. As illustrated in FIGURE 11, during delivery of the aspiration catheter 280, the proximal end of the guidewire is inserted into the distal end of the guidewire lumen 286, and the guidewire lumen 286 is slidably advanced over the guidewire. Unlike the over-the-wire catheter 260 described above, only a short segment of the single operator aspiration catheter 280 rides over the guidewire, and the guidewire remains in the guidewire lumen 286 and does not enter the aspiration lumen 284 of the aspiration catheter 280. With the single operator system 280, the long guidewire used with the over-the-wire catheter 260, and the extra operator needed to handle it, are not required.

20 25 30 Although the guidewire lumen 286 is shown in FIGURE 10 as being located only on the distal end 288 of the shaft of the aspiration catheter 280, the lumen 286 can also be made to extend the entire length of the shaft 280 if desired. In both embodiments, the aspiration lumen 284 is advantageously left completely unobstructed to provide more efficient aspiration. The guidewire lumen 286 can also include a slit in the outside wall of the lumen to facilitate faster and easier insertion and removal of the guidewire through the side wall of the lumen.

35 In another embodiment not shown, the aspiration catheter can be configured such that the therapy catheter can be inserted through the lumen of the aspiration catheter. The lumen is made large enough to accommodate the

desired therapy catheter. This allows the aspiration catheter and the therapy catheter to be delivered into the patient at the same time. When therapy is complete, the therapy catheter is removed while the aspiration catheter remains in place. This eliminates the need to separately deliver the aspiration catheter after removal of the therapy catheter, saving valuable time.

5 In yet another embodiment, also not shown, the therapy catheter can be built over the aspiration catheter. For example, a dual or triple lumen catheter having a dilatation balloon at its distal end can be used. One lumen is used to inflate the dilatation balloon to be used for angioplasty, while the second lumen is used for aspiration. The third lumen is used as a guidewire lumen. Alternatively, the aspiration catheter can be designed to deploy a stent within the occluded artery, or could include an atherectomy device on its distal end. These designs allows a
10 single combined aspiration catheter and therapy catheter to be delivered into the patient. When therapy is complete, aspiration is carried out without the need to first remove the therapy catheter or separately deliver an aspiration catheter.

FIGURE 12 is a side view of an irrigation catheter 140 or aspiration catheter which also may be utilized. It should be understood that when an irrigation catheter is used, aspiration occurs through the outer pathway
15 between the irrigation and main catheters, while irrigation occurs through the irrigation pathway. Similarly, when an aspiration catheter is used, aspiration occurs through the aspiration catheter while irrigation occurs through the pathway between the aspiration and main catheters. Irrigation fluid is supplied under pressure at the proximal end of the catheter 142 and delivered through the side holes 146 and through the distal end of the catheter 144. Alternatively, aspiration can be provided at the proximal end of the catheter 142 and fluid and debris aspirated
20 through the side holes 146 and through the distal end of the catheter 144. The catheter 140 can be about 125 centimeters in length and constructed from a plastic material such as HYTREL tubing or high density polyethylene (HDPE) or PEBAX (Atochem, France). In order to achieve a softer distal section, the durometer of the tube 148 material is reduced in the distal section to about 55 whereas that of the proximal section 142 is higher, such as about 80. Proximal valves and fittings which are well known in the art can be mounted on the catheter 140 of
25 FIGURE 12.

FIGURES 13-16 illustrate another type of irrigation or aspiration catheter 230, a single operator catheter, which can be used in the present system. In the case of the irrigation catheter, irrigation is through the inner pathway and aspiration is through the outer pathway. If the catheter is used for aspiration, aspiration is through the inner pathway and irrigation is through the outer pathway. As shown in FIGURES 13-16, the catheter 230 has an adaptor 232 on its proximal end. This single operator catheter 230 further comprises a long tubular body 236
30 having a distal end 238. The distal tip 238 can include a radiopaque marker to aid in locating the tip 238 during insertion into the patient, and is preferably soft to prevent damage to the patient's vasculature. At the distal end of the shaft 238, an inner catheter lumen 240 is attached. This lumen 240 provides a separate lumen, apart from the main irrigation or aspiration lumen 242 of the catheter 230, for the insertion of the inner catheter, and has an
35 inner diameter sized to received the inner catheter. In a preferred embodiment, the inner diameter of the lumen is about .016" to about .020", and more preferably is about .019". This inner catheter or guidewire lumen can be as

short as 5 centimeters, but can extend 30 centimeters or longer in a proximal direction. During delivery of the catheter 230, the proximal end of the inner catheter is inserted into the distal end of the inner catheter lumen 240, and the lumen 240 is slidably advanced over the inner catheter. Only a short segment of the single operator catheter 230 rides over the inner catheter, and the inner catheter remains in the lumen 240 and does not enter the main lumen 242 of the catheter 230.

Although the inner catheter lumen 240 is shown in FIGURE 13 as being located only on the distal end 238 of the shaft of the catheter 236, the lumen 240 can also be made to extend the entire length of the shaft 236 if desired. In both embodiments, the main lumen 242 is advantageously left completely unobstructed to provide more efficient irrigation or aspiration. As seen in FIGURE 16, the inner catheter lumen 240 can also include a slit 241 or weakened area in the outside wall of the lumen 240 along the entire length of the lumen 240 to facilitate faster and easier insertion and removal of the inner catheter through the side wall of the lumen 240. By inserting and removing the inner catheter through the side wall of the lumen 240 on the catheter 236, the need to remove adapters and attachments from the proximal end prior to slidably advancing or removing the catheter 236 over the inner catheter is eliminated. It should be understood that this slit 241 or weakened area through which the inner catheter can be inserted and removed can exist on the intermediate catheter regardless of whether the catheter is used for irrigation, aspiration, therapy or some other purpose.

In another embodiment, not shown, the irrigation and aspiration are conducted through a multi lumen catheter. In this embodiment, a single catheter is used. The catheter includes at least two separate lumens; one lumen is used for aspiration and has a source of negative pressure attached at the proximal end, while a second lumen is used to provide irrigation and has a source of irrigation fluid attached at the proximal end.

Use of the devices just described will now be explained in connection with the method of the present invention.

Method of the Present Invention

A. Dual Balloon System

One embodiment of the method of the present invention as used to remove plaque and any associated thrombi from the internal carotid artery 400 is described below in connection with FIGURE 17. It should be noted that this example is merely exemplary, and the method can be used to treat occlusions within the external carotid 402, or common carotid 404 artery or other arteries above the aortic arch as well.

A main catheter or guide catheter 406 is introduced into the patient's vasculature through an incision in the femoral artery in the groin of the patient, or through direct access to the arteries in the neck. The main catheter 406 has a lumen sized to receive other catheters and devices, and can be used to guide the insertion of these other catheters and devices. The main catheter 406 is guided through the vasculature until it reaches the common carotid artery 404, where it can remain in place throughout the procedure. Fluoroscopy is typically used to guide the main catheter 406 and other devices to the desired location within the patient. The devices are frequently marked with radiopaque markings to facilitate visualization of the insertion and positioning of the devices within the patient's vasculature.

Once the main catheter 406 is in place, with its occlusive device 408 at a position proximal to the occlusion 410, the occlusive device 408 is activated. Downstream blood flow is effectively stopped, and blood flow coming from collateral blood vessels distal to the occlusive device prevents the downstream migration of any free particles. In this example, the occlusive device 408 is an inflatable balloon. The balloon is inflated to occlude the common carotid artery 404.

Next, an inner catheter or guidewire 420 having an occlusive device 422 at its distal end is delivered through the main catheter 406 into the internal carotid artery 400 and past the site of the occlusion 410. Alternatively, a detachable occlusive device can be deployed at the site distal to the occlusion, and the delivery device removed. In this example, the occlusive device 422 is also an inflatable balloon. The balloon is inflated to occlude the internal carotid artery at a site distal to the occlusion 410. It should be understood that the occlusion within the artery can be in a discrete location or diffused within the vessel. Therefore, although placement of the distal occlusive device is said to be distal to the occlusion to be treated, portions of the diffuse occlusion may remain distal to the occlusive device.

A working area is therefore created between the two occlusive devices 408, 422 surrounding the occlusion 410. A therapy catheter (not shown) is then delivered. The therapy catheter can be any of a number of devices, including a balloon catheter used to perform angioplasty, a catheter which delivers a stent, a catheter for delivering enzymes, chemicals, or drugs to dissolve and treat the occlusion, an atherectomy device, a thrombectomy device, a rheolytic device, a device which creates a venturi effect within the artery, or a laser or ultrasound device used to ablate the occlusion.

Once the desired therapy is performed, the therapy catheter is withdrawn from the patient's body and an aspiration catheter 424 is delivered through the main catheter 406, preferably over the inner catheter or guidewire 420. The aspiration catheter 424 rides over the guidewire 420 with the guidewire 420 inserted through the aspiration lumen of the catheter 424. Alternatively, a single operator type aspiration catheter can be used, in which only a portion of the aspiration catheter rides over the guidewire, which is inserted into a separate guidewire lumen. FIGURE 17 illustrates the treatment site after the over-the-wire aspiration catheter 424 is inserted into the internal carotid artery 400.

After the aspiration catheter 424 is in place, aspiration is begun. A source of negative pressure is connected to the aspiration catheter 424 at its proximal end. A preferred source of negative pressure is any container containing a fixed vacuum, such as a syringe, attached to the proximal end of the aspiration catheter 424 at the aspiration port. A mechanical pump or bulb or any other appropriate source of negative pressure can also be used, including the creation of a venturi effect within the blood vessel. The difference between the existing pressure within the vessel and the aspiration or negative pressure within the vessel should not exceed about 50 psi. If too much aspiration is applied, the change in pressure in the vessel will be too great and damage may occur to the vessel itself.

Prior to aspiration, simultaneous with aspiration, or after aspiration is begun, the proximal occlusive device 408 is deactivated to allow blood flow into the area. The blood flow into the area provides irrigation fluid which

creates turbulence and facilitates the removal of particles and debris. Preferably, the anatomical irrigation pressure provided is approximately 1-1.5 psi, and the blood flow into the area is at least 10 cubic centimeters/min and more preferably about 60-80 cubic centimeters/min. In a preferred embodiment, the proximal occlusive device is then reactivated, and the distal occlusive device is deactivated. This allows blood flow into the working area from the distal end. Following aspiration, the distal occlusive device is reactivated. This method of alternately deactivating and reactivating the occlusive devices acts to contain and direct the emboli and particles to an area within the working area where they will be aspirated. Particles are initially contained between the two occlusive devices. When the proximal occlusion device is deactivated, blood flow forces particles and debris toward the distal end of the working area. The working area is aspirated, and the occlusive device reactivated. When the distal occlusive device is deactivated, blood flow forces particles and debris back toward the proximal end of the working area, where they are then aspirated. The steps of deactivating and reactivating the occlusive devices and aspirating the working area can be repeated as often as desired, until the working area is substantially free of particles and debris.

When the deactivating and reactivating of the occlusive devices and aspiration steps are complete, the aspiration catheter is removed, and the occlusive devices are deactivated. The main and inner catheters are also removed from the patient.

As described above, the aspiration catheter can be sized such that it can receive the therapy catheter within its lumen. In this case, the aspiration catheter and the therapy catheter are delivered into the artery together. When therapy is complete, the therapy catheter is removed while the aspiration catheter remains in place. When aspiration is complete, the aspiration catheter, inner catheter and main catheter are removed from the patient's body. Delivering the aspiration catheter and therapy catheter together saves time, which is critical during these types of procedures.

In yet another embodiment, aspiration takes place through the lumen of the inner catheter or guidewire. The occlusive device on the inner catheter is positioned distal to the occlusion, and the occlusive device is activated to at least partially occlude the vessel. The therapy catheter is delivered and therapy performed. A source of negative pressure is provided at the proximal end of the inner catheter, and aspiration occurs through openings located at the distal end of the catheter just proximal to the occlusive device. This eliminates the need for a separate aspiration catheter, and the need to remove the therapy catheter prior to aspiration. Again, this saves time, which is critical during these types of procedures.

B. Triple Balloon System

In another embodiment illustrated in FIGURE 18, a third occlusive device 430 is used to occlude the external carotid artery 402. Once the main catheter 406 is in place and the common carotid artery 404 is occluded, inner catheters 420, 432 are delivered to both the internal 400 and external 402 carotid artery branches and occluded. Following therapy and aspiration of the internal carotid artery 400, the aspiration catheter is moved in a proximal direction, and delivered over the inner catheter 420 into the external carotid artery branch 402. Aspiration is then performed in that branch to remove any particles or debris that may have been moved into the external carotid artery 402. The three occlusive devices can be alternately deactivated and reactivated as described above, to ensure the

desired clearance of the working area. When aspiration is complete, the occlusive devices are deactivated, and the main 406, aspiration, and inner catheters 420, 432 are removed from the patient.

Should it be desired that a separate irrigation catheter be used to provide irrigation fluid, an irrigation catheter can be delivered to the site of the occlusion following therapy and removal of the therapy catheter. The irrigation catheter is delivered through the main catheter and over the inner catheter. Irrigation fluid is provided through the irrigation catheter, while aspiration is provided through the main catheter.

C. Single Balloon System

In another embodiment illustrated in FIGURE 19, only a single occlusive device is used. As described above, a main catheter 406, with or without a distal occlusive device, is introduced into the patient's vasculature through an incision in the femoral artery in the groin of the patient or through direct access to the arteries in the neck. The main catheter 406 is guided through the vasculature until it reaches the common carotid artery 404, where it can remain in place throughout the procedure.

Once the main catheter 406 is in place proximal to the occlusion 410, an inner catheter or guidewire 420 having an occlusive device 422 at its distal end is delivered through the main catheter 406 into the internal carotid artery 400 and past the site of the occlusion 410. Alternatively, a detachable occlusive device can be deployed at the site distal to the occlusion, and the delivery device removed. In this example, the occlusive device 422 is an inflatable balloon. The balloon is inflated to occlude the internal carotid artery 400 at a site distal to the occlusion 410. As noted before, it should be understood that the occlusion within the artery can be in a discrete location or diffused within the vessel. Therefore, although placement of the distal occlusive device is said to be distal to the occlusion to be treated, portions of the diffuse occlusion may remain distal to the occlusive device.

A therapy catheter, not shown, is then delivered. Again, the therapy catheter can be any of a number of devices, including a balloon catheter used to perform angioplasty, a catheter which delivers a stent, a catheter for delivering enzymes, radiation, chemicals, or drugs to dissolve and treat the occlusion, an atherectomy device, a thrombectomy device, a rheolitic device, a device which creates a venturi effect within the artery, or a laser or ultrasound device used to ablate the occlusion.

Once the desired therapy is performed, the therapy catheter is withdrawn from the patient's body and an intermediate catheter 426 is delivered through the main catheter 406. A single operator type catheter may be used in which only a portion of the catheter rides over the guidewire, which is inserted into a separate guidewire lumen (as illustrated in FIGURE 20). Alternatively, an over-the-wire type catheter can be used. The intermediate catheter 426 is delivered into the internal carotid artery 400 to a location just proximal to the occlusive device 422. Preferably, in order to maximize the effectiveness of the aspiration or irrigation, the catheter 426 is positioned less than two centimeters from the proximal end of the occlusive device 422 at some point during aspiration. Delivering the intermediate catheter 426 in such close proximity to the occlusion device 422 will allow the creation of a turbulent effect near the occlusive device during aspiration and irrigation thus aiding in the removal of the particles and debris. During aspiration, the intermediate catheter 426 can be moved in a proximal direction, to ensure more effective aspiration of the area.

Delivery of the intermediate catheter 426 near the occlusive device 422 requires passing the intermediate catheter 426 across the previously occluded vessel. In order to minimize the risk to the patient the intermediate catheter 426 is preferably soft, small and flexible. A preferred embodiment of this invention comprises delivering a soft-tipped intermediate catheter 426 made of a compound of a durometer 55 or less.

5 Once the intermediate catheter 426 is delivered in close proximity to the occlusive device 422, the area is first aspirated. As noted above, the intermediate catheter 426 can be moved backward in a proximal direction during aspiration. This forward and backward movement of the intermediate catheter 426 can be repeated as often as desired to provide effective aspiration. At some point during aspiration, the distal end of the aspiration catheter should be positioned about 2 cm or less from the proximal end of the occlusive device to ensure effective aspiration.
10 Following aspiration, the area is irrigated by supplying a fluid, such as saline, through the intermediate catheter 426. The irrigation fluid acts to flush any remaining particles or debris from the internal carotid 400, to the external carotid 402, as indicated by the arrows in FIGURE 21. The steps of sequential aspiration and irrigation or flushing, can be repeated as many times as necessary to remove all of the particles and debris from the vessel.

15 In one embodiment, the intermediate catheter 426 has a single lumen for delivery of aspiration pressure and irrigation fluid, such as the aspiration or irrigation catheters shown in FIGURES 7 through 16. The proximal end of the intermediate catheter 426 is connected to a source of negative pressure (as described above) and is used to aspirate the debris and particles around the occlusive device 422.

20 Following aspiration of the area, the proximal end of the intermediate catheter 426 is connected to a source of irrigation fluid, such as saline, in order to irrigate the area near the occlusive device 422. Preferably, the volume of fluid used to irrigate the area near the occlusive device 422 is equal to or greater than the volume of the area between the proximal end of the distal occlusive device and the start of the internal carotid artery at the bifurcation of the common carotid artery. For example, at least 10 cubic centimeters of fluid is delivered to the area that is between the distal occlusive device and the start of the internal carotid branch, which is approximately 1-5 cubic centimeters. As a result of this irrigation, any particles or debris remaining in the internal carotid 400 will be flushed
25 into the external carotid 402.

30 In yet another embodiment, the intermediate catheter 426 has two lumens, one for aspiration and another for irrigation. The lumen providing aspiration is attached at its proximal end to a negative pressure source. A second lumen is attached at its proximal end to source of irrigation fluid. An advantage of this embodiment is that the particles and debris removed are in a separate lumen, eliminating the possibility that they could be flushed back into the vessel when the irrigation fluid is delivered through the same lumen as the aspiration pressure. As with the single lumen embodiment, the steps of aspirating and irrigating can be repeated as many time as necessary.

D. Alternate Dual Balloon System

35 Under certain circumstances, use of a second occlusive device is desired, as illustrated in FIGURE 21. In this embodiment, the second occlusive device 432 is positioned on the distal end of the main catheter 406 and acts to occlude the main carotid artery 404. A second occlusive device 432 may be desired where the physician is concerned about crossing the occlusion 410 in the internal carotid artery 400 with the inner catheter 420 or where

there is another occlusion 428 in the external carotid artery 402 resulting in decreased flow through the external carotid 402.

Once the main catheter 406 is delivered to the common carotid artery 404, the occlusive device 432 is activated. The activation of the occlusive device 432 will have the effect of occluding the common carotid artery 404 thereby cutting off the blood flow to both the internal carotid 400 and the external carotid 402 arteries.

Next, an inner catheter 420 with an occlusive device 422 is delivered distal to the occlusion 410 in the internal carotid artery 400 and activated, thus isolating the occlusion 410 between the two occlusive devices 432, 422. This is followed by therapy on the occlusion 410 as described above. Sequential aspiration and irrigation are then performed as described above.

The main advantage of using two occlusive devices is that when the internal carotid artery 400 is irrigated, a back pressure is created in the chamber defined by the proximal occlusive device 432 and the distal occlusive device 422. This back pressure will force the fluid, particles and debris from the internal 400 and common 404 carotid arteries through the external carotid artery 402.

E. Alternate Triple Balloon System

In some cases, a triple balloon system is used. This embodiment is especially advantageous in those patients where occlusion of the common carotid artery results in blood from collateral vessels flowing from the external carotid artery to the internal carotid artery. The direction of blood flow in a particular patient can be determined through angiography.

In this system (not shown), following activation of the occlusive device in the common carotid artery, but before crossing the occlusion with an inner catheter, a first inner catheter with an occlusive device is delivered to the external carotid artery and the occlusive device activated. This prevents flow from collateral blood vessels moving from the external to the internal carotid artery. Next, a second inner catheter is delivered to the internal carotid artery past the site of the occlusion and the occlusive device activated to occlude the internal carotid artery. Alternatively, the first inner catheter can be positioned within the internal carotid artery and the occlusive device activated, followed by delivery of the second inner catheter to the external carotid artery and activation of the occlusive device. In either case, the occlusion is completely isolated between the three occlusive devices. This is followed by therapy on the occlusion, aspiration, and irrigation if desired, as described above.

In yet another aspect, there is provided a method of performing a diagnostic procedure in the carotid arteries in which the preferred intravascular catheters, as described herein, are utilized to remove emboli, thrombus, and other obstructions from the vessel of a patient, as shown in FIGURE 21, in order to determine the nature of such obstruction. For example, the aspirated or otherwise removed obstruction can be analyzed visually or in the laboratory. If this analysis indicates that it is in the nature of a thrombus or similar blood clot, then the patient may be treated with suitable anti-clotting medication. On the other hand, if the aspirated obstruction is in the nature of an embolus, which may comprise plaque, then the patient may be treated with suitable anti-cholesterol medication. In addition, as a result of such a diagnostic procedure, the stenosis or other lesion which produced such plaque may be irradiated in order to decrease the risk of reoccurrence. Thus, there is provided this preferred diagnostic method in which an intravascular aspiration system is used to remove obstructions from the vasculature of a patient for further analysis.

WHAT IS CLAIMED IS:

1. A kit comprising a plurality of catheters in combination for use in removal of occlusions in blood vessels, characterized in that the plurality of catheters comprises:

a main catheter having an occlusive device;

an inner catheter having an occlusive device;

a therapy catheter; and

an aspiration catheter.

2. The kit of Claim 1, further characterized in that each of said catheters is capable of independent manipulation.

3. The kit of either Claim 1 or Claim 2, for use in carotid arteries.

4. The kit of either Claim 1 or Claim 2, further characterized in that the inner catheter bearing an occlusive device comprises an elongated tubular body, an inflatable balloon mounted on a distal end of the tubular body, a core-wire joined to the distal end of the tubular body, and a coil member disposed about the core-wire.

5. The kit of either Claim 1 or Claim 2, further characterized in that the aspiration catheter comprises an elongate hollow shaft, a distal tip adapted for aspiration therethrough, and a proximal end adapted for connection with a source of negative pressure.

6. A method for the treatment of an occlusion in a carotid artery, comprising, in order, the following steps:

delivering a main catheter having a first occlusive device on its distal end into said artery, until said occlusive device is proximal to said occlusion;

activating said first occlusive device to occlude said artery proximal to said occlusion;

delivering an inner catheter having a second occlusive device on its distal end into said artery, until said occlusive device is distal to said occlusion;

activating said second occlusive device to occlude said artery distal to said occlusion and create a working area surrounding said occlusion;

delivering a therapy catheter into said artery until it reaches said occlusion;

performing therapy on said occlusion;

removing said therapy catheter from said patient;

delivering a distal end of an aspiration catheter to said working area;

deactivating said first occlusive device on said main catheter to allow blood flow into said working area; and

aspirating said working area following the deactivating of the first occlusive device.

7. The method of Claim 6, further comprising the steps of reactivating said first occlusive device, deactivating said second occlusive device, and aspirating said working area, in order, following the step of deactivating of the second occlusive device.

8. The method of Claim 7, further comprising the step of reactivating the second occlusive device after the step of deactivating the second occlusive device, and wherein said deactivating the first occlusive device, aspirating, reactivating the first occlusive device, deactivating the second occlusive device, and aspirating steps are repeated at least once in order.

5 9. The method of Claim 6, wherein said inner catheter comprises a guidewire.

10. The method of Claim 6, wherein said activating step results in the vessel being substantially occluded.

11. The method of Claim 6, wherein said first and second occlusive devices are balloons and said activating steps comprise inflating said balloons.

10 12. The method of Claim 6, wherein said second occlusive device is a filter and said activating step comprises deploying said filter to prevent migration of particles downstream.

13. The method of Claim 6, wherein said performing step comprises performing a method selected from the group consisting of delivering a drug directly to the site of said occlusion, performing balloon angioplasty, deploying a stent, and performing atherectomy.

15 14. The method of Claim 6, wherein said performing step comprises creating a venturi effect within said vessel to aspirate said occlusion, and wherein said aspirating step occurs simultaneously.

15. The method of Claim 6, wherein said performing step comprises creating turbulence within said vessel, and wherein said aspirating step occurs simultaneously.

20 16. The method of Claim 6, wherein said therapy catheter is selected from the group consisting of a thrombectomy catheter, a rheolytic device, and a device which creates a venturi effect within the vessel, and wherein said performing and said aspirating steps are performed simultaneously.

17. The method of Claim 6, wherein said deactivating and said aspirating steps are performed simultaneously.

18. The method of Claim 6, further comprising the step of aspirating prior to said deactivating step.

25 19. The method of Claim 6, wherein said artery comprises at least two branches, and said second occlusive device is delivered to one of said branches and said method further comprises, in order, delivering a second inner catheter having a third occlusive device on its distal end to the other branch, activating said third occlusive device to occlude said second branch, and aspirating both branches of said artery to remove particles and debris.

30 20. The method of Claim 19, further comprising reactivating said first occlusive device following said aspirating step, then deactivating said second and third occlusive devices, and then aspirating said working area following the deactivating of the second and third occlusive devices.

21. The method of Claim 20, further comprising reactivating said second and third occlusive devices after said aspirating step, and wherein said reactivating said first occlusive device, deactivating said second and third occlusive devices and said aspirating steps are repeated at least once.

22. The method of Claim 6, wherein said therapy catheter is inserted into said aspiration catheter prior to said delivery of said therapy catheter, and said aspiration and therapy catheters are delivered into the artery together.

23. The method of Claim 6, wherein said therapy catheter comprises a catheter capable of performing therapy and providing aspiration, such that said aspiration and therapy catheters comprise a single catheter which is delivered and removed from said artery.

24. A method for the treatment of an occlusion in a carotid artery, comprising, in order, the following steps:

delivering a main catheter having a first occlusive device on its distal end into said artery, until said occlusive device is proximal to said occlusion;

activating said first occlusive device to occlude said artery proximal to said occlusion;

delivering an inner catheter having a second occlusive device on its distal end into said artery, until said occlusive device is distal to said occlusion;

activating said second occlusive device to occlude said artery distal to said occlusion and create a working area surrounding said occlusion;

delivering a therapy catheter into said artery until it reaches said occlusion;

performing therapy on said occlusion;

removing said therapy catheter from said patient;

deactivating said first occlusive device on said main catheter to allow blood flow into said working area; and

aspirating said working area through said main catheter following the deactivating of the first occlusive device.

25. The method of Claim 24, further comprising, in order, the steps of reactivating said first occlusive device after said aspirating step, deactivating said second occlusive device, and aspirating said working area following the deactivating of the second occlusive device.

26. The method of Claim 25, further comprising the step of reactivating the second occlusive device after the deactivating of the second occlusive device, and wherein said deactivating the first occlusive device, aspirating, reactivating the first occlusive device, deactivating the second occlusive device, and aspirating steps are repeated at least once.

27. The method of Claim 24, wherein said activating step results in the vessel being substantially occluded.

28. The method of Claim 24, wherein said first and second occlusive devices are balloons and said activating steps comprise inflating said balloons.

29. The method of Claim 24, wherein said first and second occlusive devices are filters and said activating steps comprise deploying said filters to prevent migration of particles downstream.

30. The method of Claim 24, wherein said performing step comprises performing a method selected from the group consisting of delivering a drug directly to the site of said occlusion, performing balloon angioplasty, deploying a stent, and performing atherectomy.

5 31. The method of Claim 24, wherein said performing step comprises creating a venturi effect within said vessel to aspirate said occlusion, and wherein said aspirating step occurs simultaneously.

32. The method of Claim 24, wherein said performing step comprises creating turbulence within said vessel, and wherein said aspirating step occurs simultaneously.

10 33. The method of Claim 24, wherein said therapy catheter is selected from the group consisting of a thrombectomy catheter, a rheolitic device, and a device which creates a venturi effect within the vessel, and wherein said performing and said aspirating steps are performed simultaneously.

34. The method of Claim 24, wherein said deactivating and said aspirating steps are performed simultaneously.

35. The method of Claim 24, wherein said aspirating step is performed first, followed by said deactivating step.

15 36. The method of Claim 24, further comprising delivering a distal end of an irrigation catheter into said working area following the removal of said therapy catheter, delivering irrigation fluid through said irrigation catheter into said working area and then aspirating through said main catheter.

20 37. The method of Claim 24, wherein said artery comprises at least two branches, and said second occlusive device is delivered to one of said branches and said method further comprises, in order, the steps of delivering a second inner catheter having a third occlusive device on its distal end to the other branch, activating said third occlusive device to occlude said second branch, and aspirating both branches of said artery following the deactivating of said occlusive devices to remove particles and debris.

38. The method of Claim 37, further comprising reactivating said first occlusive device following said aspirating step, then deactivating said second and third occlusive devices, and then aspirating said working area.

25 39. The method of Claim 38, further comprising reactivating said second and third occlusive devices after said aspirating step, and wherein said reactivating said first occlusive device, deactivating said second and third occlusive devices and said aspirating steps are repeated at least once.

40. The method of Claim 24, wherein said aspirating occurs through said inner catheter.

30 41. A method for the treatment of an occlusion in a carotid artery, comprising, in order, the following steps:

delivering a main catheter into said artery, until a distal end of said catheter is proximal to said occlusion;

delivering an inner catheter having an occlusive device on its distal end into said artery, until said occlusive device is distal to said occlusion;

35 activating said occlusive device to occlude said artery distal to said occlusion;

delivering a therapy catheter into said artery until it reaches said occlusion;

performing therapy on said occlusion;
removing said therapy catheter from said patient;
delivering a distal end of an intermediate catheter proximal to said occlusive device;
aspirating an area proximal to said occlusive device using said intermediate catheter to remove
5 particles and debris; and
irrigating said area proximal to said occlusive device using said intermediate catheter following.

42. The method of Claim 41, wherein said aspirating and irrigating steps are repeated at least once.

43. The method of Claim 41, wherein the intermediate catheter comprises a single lumen and said
aspirating and irrigating steps are performed through said lumen.

10 44. The method of Claim 41, wherein the intermediate catheter comprises two or more lumens, and
said aspirating and irrigating steps are performed through different lumens.

45. The method of Claim 41, wherein the irrigating step comprises irrigating with saline solution.

46. The method of Claim 41, wherein said inner catheter comprises a guidewire.

47. The method of Claim 41, wherein said activating step results in the artery being substantially
15 occluded.

48. The method of Claim 41, wherein said occlusive device is a balloon and said activating step
comprises inflating said balloon.

49. The method of Claim 41, wherein said occlusive device is a filter and said activating step
comprises deploying said filter to prevent migration of particles downstream.

20 50. The method of Claim 41, wherein said performing step comprises performing a method selected
from the group consisting of delivering a drug directly to the site of said occlusion, performing balloon angioplasty,
deploying a stent, and performing atherectomy.

51. The method of Claim 41, wherein said therapy catheter is selected from the group consisting of
a thrombectomy catheter, a rheolitic device, and a device which creates a venturi effect within the vessel, and
25 wherein said performing and said aspirating steps are performed simultaneously.

52. The method of Claim 41, wherein said main catheter further comprises an occlusive device
mounted on its distal end, and wherein said method further comprises activating said occlusive device prior to
delivering said inner catheter.

30 53. A method for the treatment of an occlusion in an internal carotid artery, comprising, in order, the
following steps:

delivering a main catheter having a first occlusive device on its distal end into a common carotid
artery, until a distal end of said catheter is proximal to said occlusion;

activating said first occlusive device;

delivering a first inner catheter having a second occlusive device on its distal end into an external
35 carotid artery;

activating said second occlusive device;

delivering a second inner catheter having a third occlusive device on its distal end into said internal carotid artery, until said third occlusive device is distal to said occlusion;

activating said third occlusive device to occlude said internal carotid artery distal to said occlusion;

delivering a therapy catheter into said internal carotid artery until it reaches said occlusion;

5 performing therapy on said occlusion;

removing said therapy catheter from said patient;

delivering a distal end of an intermediate catheter proximal to said third occlusive device; and

aspirating an area proximal to said third occlusive device using said intermediate catheter to remove particles and debris.

10 54. The method of Claim 53, wherein said distal end of said intermediate catheter is delivered to a position approximately two centimeters from said occlusive device.

55. The method of Claim 54, wherein said distal end of said intermediate catheter is moved in a proximal direction during aspiration step.

56. The method of Claim 53, wherein said inner catheter comprises a guidewire.

15 57. The method of Claim 53, wherein said activating step results in the artery being substantially occluded.

58. The method of Claim 53, wherein said first, second and third occlusive device comprise a balloon and said activating steps comprise inflating said balloon.

20 59. The method of Claim 53, wherein said performing step comprises performing a method selected from the group consisting of delivering a drug directly to the site of said occlusion, performing balloon angioplasty, deploying a stent, and performing atherectomy.

60. The method of Claim 53, wherein said therapy catheter is selected from the group consisting of a thrombectomy catheter, a rheolytic device, and a device which creates a venturi effect within the vessel, and wherein said performing and said aspirating steps are performed simultaneously.

25 61. The method of Claim 53, wherein said first inner catheter is delivered into the internal carotid artery and said second occlusive device is activated therein, and said second inner catheter is delivered into the external carotid artery, and the third occlusive device is activated therein.

62. A method for the treatment of an occlusion in a carotid artery, comprising, in order, the following steps:

30 delivering a main catheter into said artery, until a distal end of said catheter is proximal to said occlusion;

delivering a guidewire having a occlusive balloon on its distal end into said artery, until said balloon is distal to said occlusion;

inflating said balloon to occlude said artery distal to said occlusion;

35 delivering a balloon angioplasty catheter into said artery until it reaches said occlusion;

performing balloon angioplasty on said occlusion;

removing said balloon angioplasty catheter from said patient;

delivering a distal end of an intermediate catheter proximal to said occlusive device;

aspirating an area proximal to said occlusive device using said intermediate catheter to remove particles and debris; and

5

irrigating said area proximal to said occlusive device using said intermediate catheter.

63. The method of Claim 62, wherein the intermediate catheter comprises a single lumen and said aspirating and irrigating steps are performed through said lumen.

64. The method of Claim 62, wherein the intermediate catheter comprises two or more lumens, and said aspirating and irrigating steps are performed through different lumens.

10

65. A method of performing a diagnostic procedure in the carotid arteries comprising the steps of removing thrombus, emboli, or other obstructions from the vasculature of the patient and analyzing such articles to determine subsequent patient treatment.

66. The method of Claim 65, wherein said diagnostic procedure is performed utilizing the catheter kit of Claim 1.

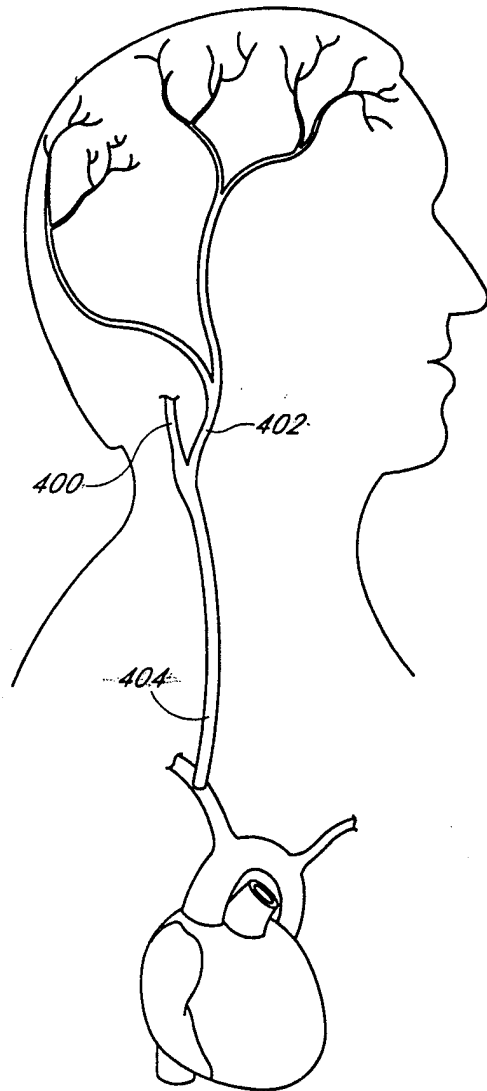

FIG. 1

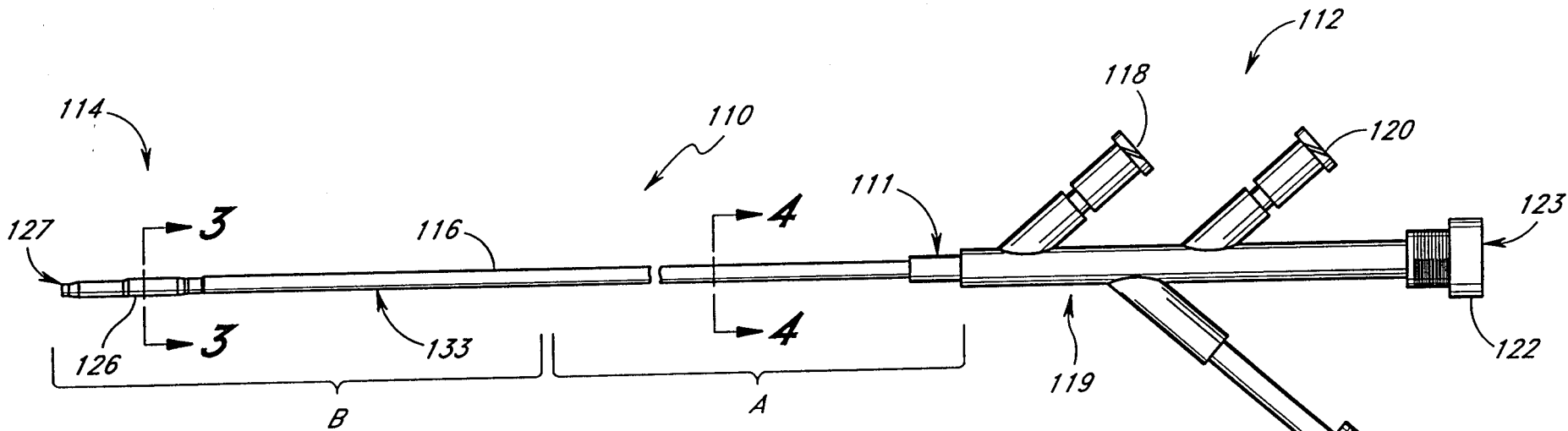

FIG. 2

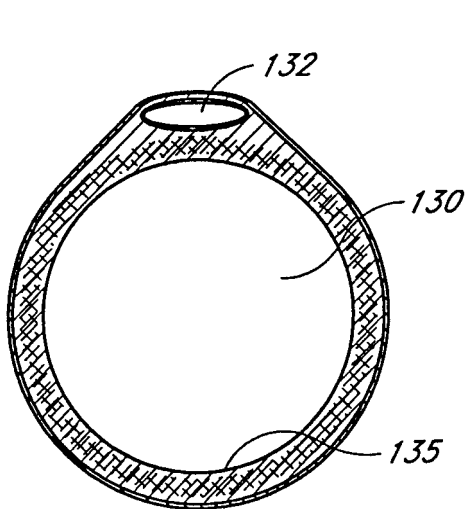

FIG. 3

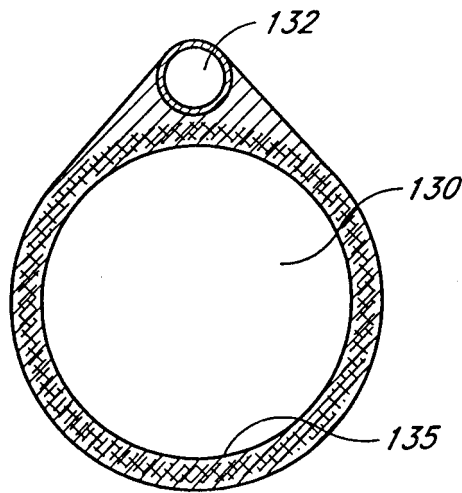

FIG. 4

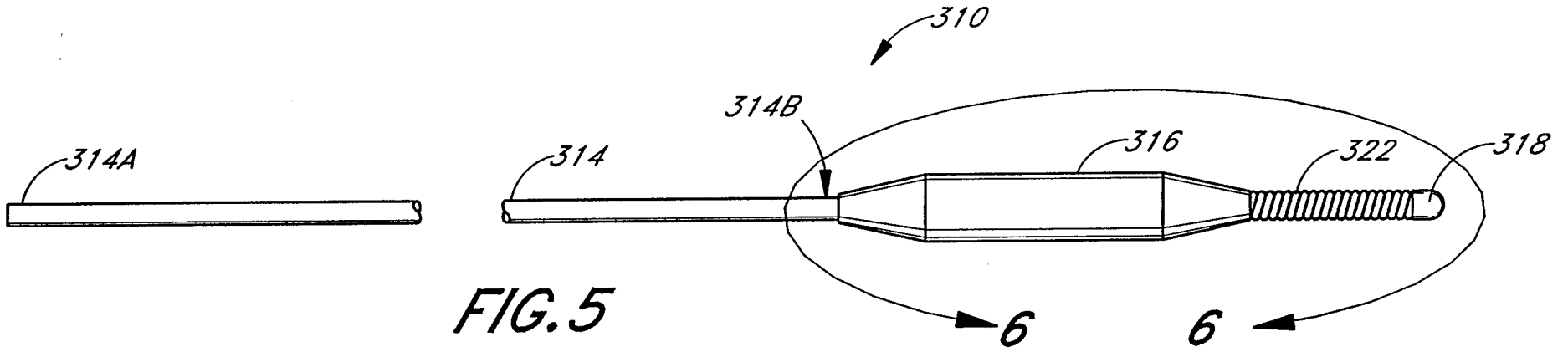

FIG. 5

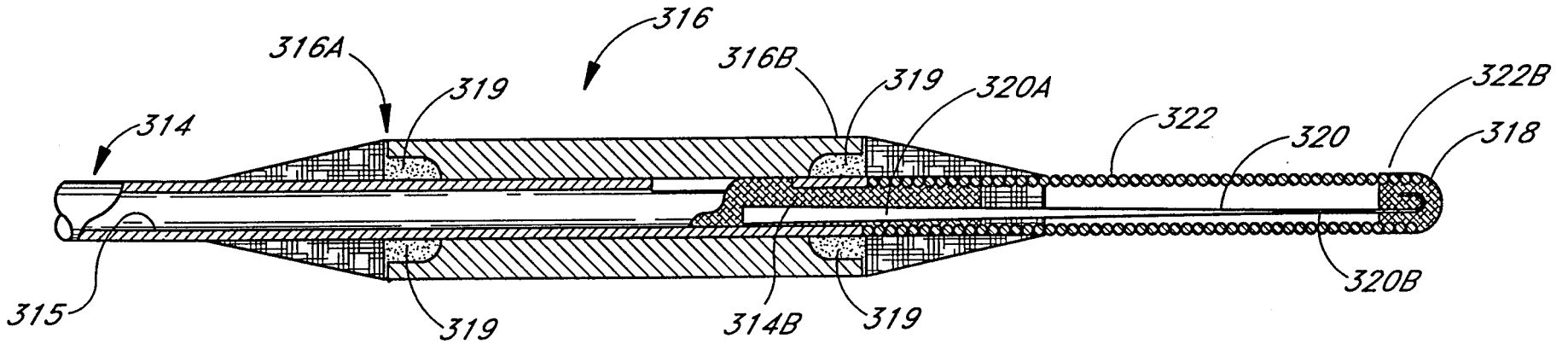

FIG. 6

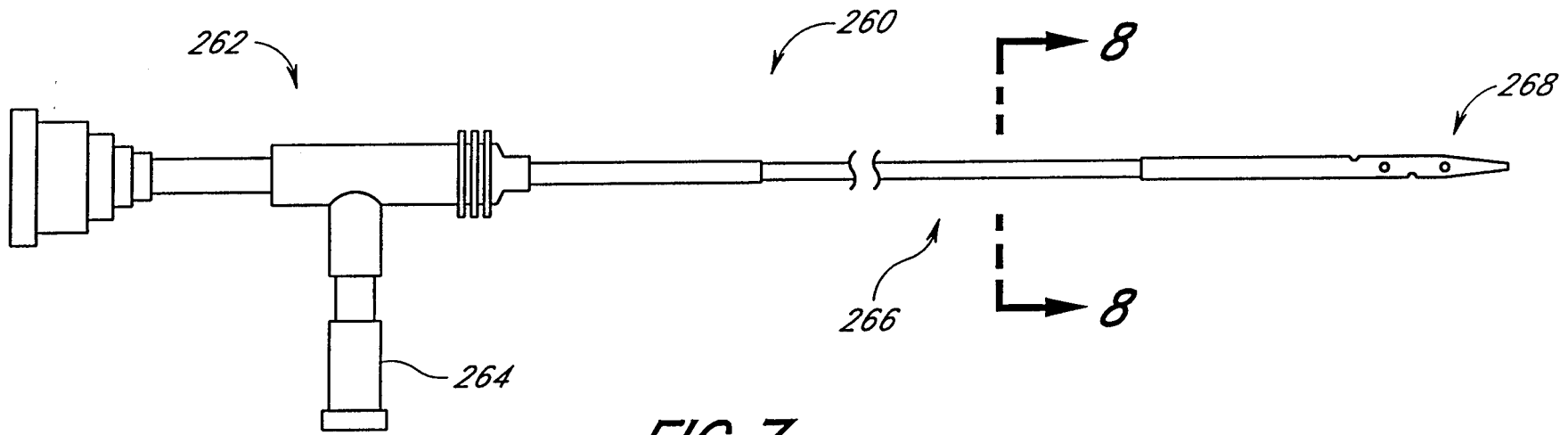

FIG. 7

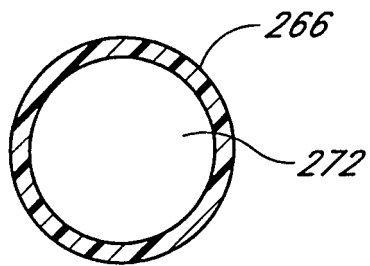

FIG. 8

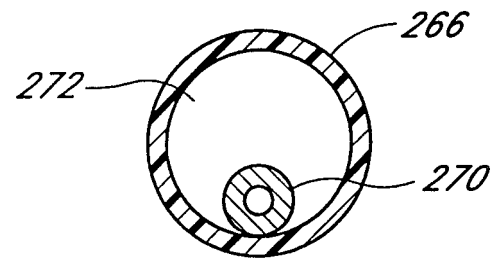

FIG. 9

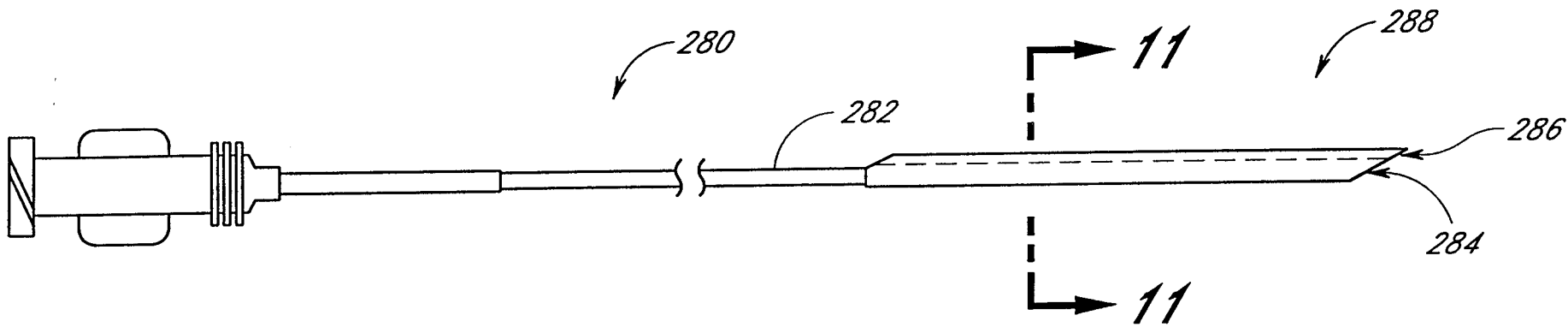

FIG. 10

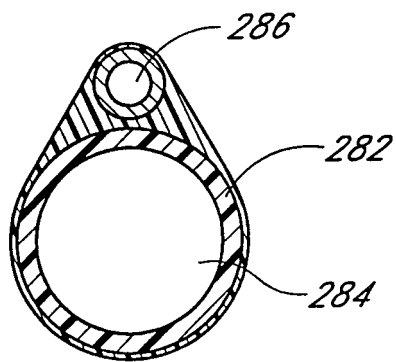

FIG. 11

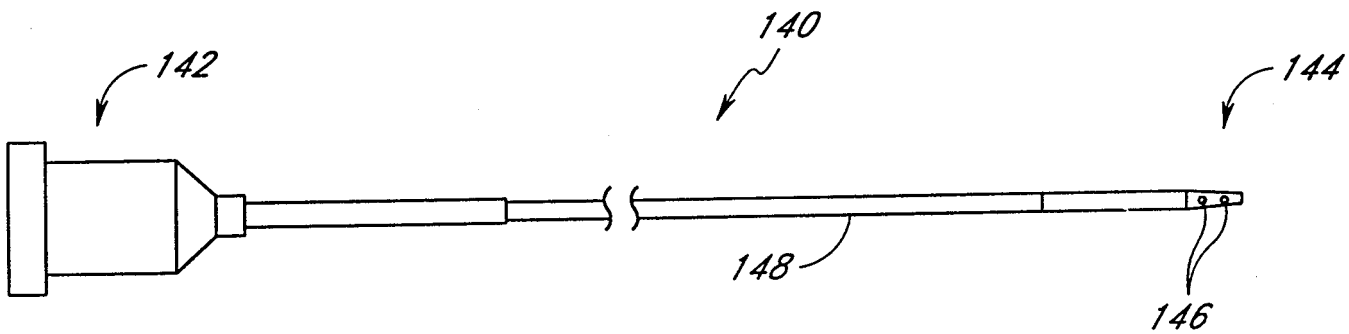

FIG. 12

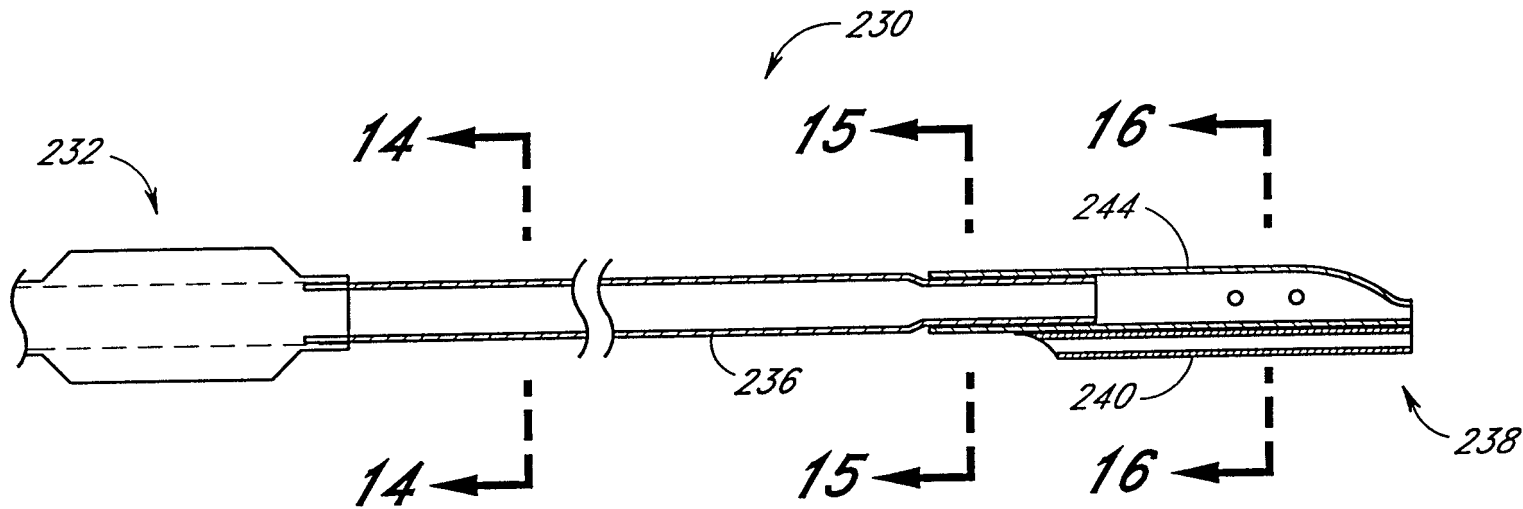

FIG. 13

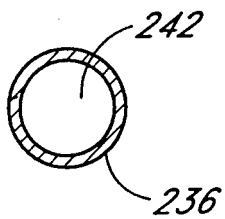

FIG. 14

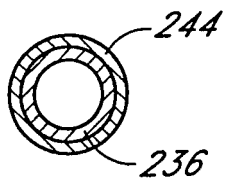

FIG. 15

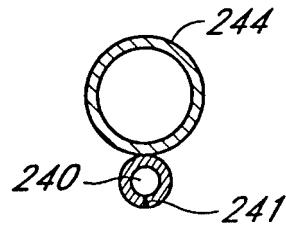

FIG. 16

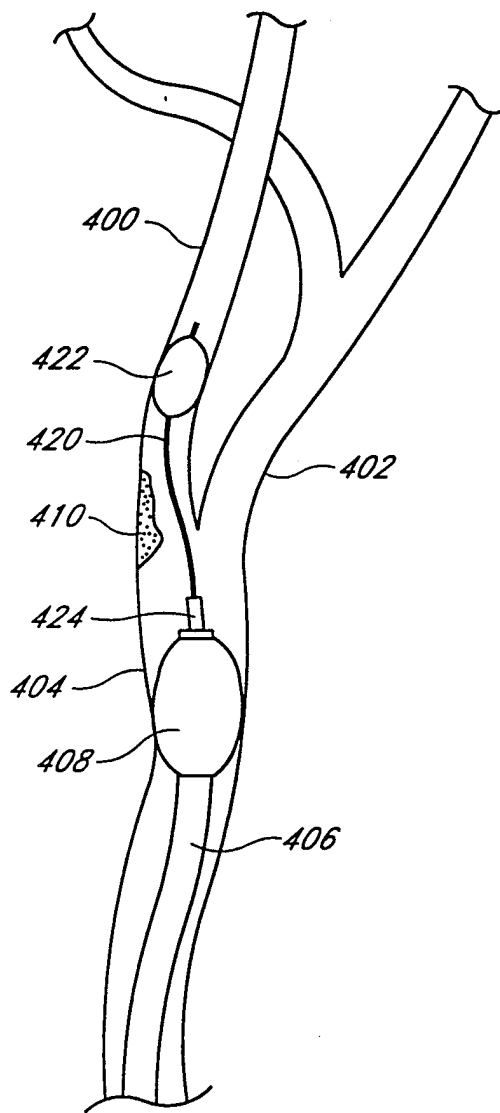

FIG. 17

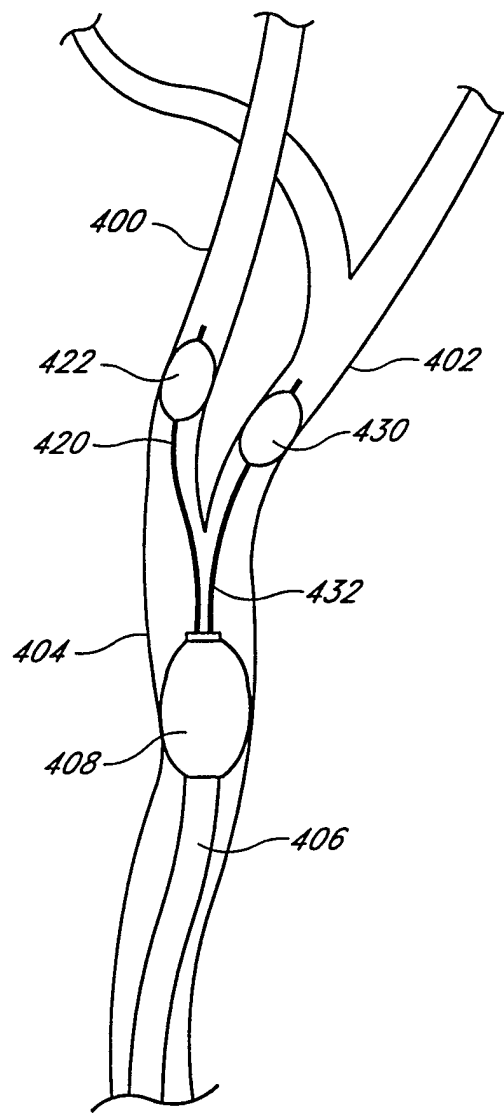

FIG. 18

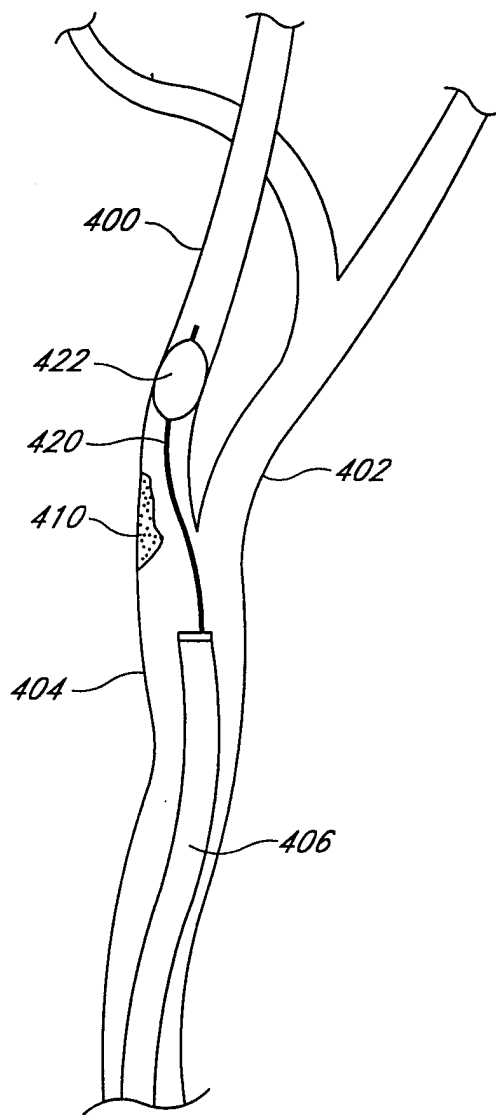

FIG. 19

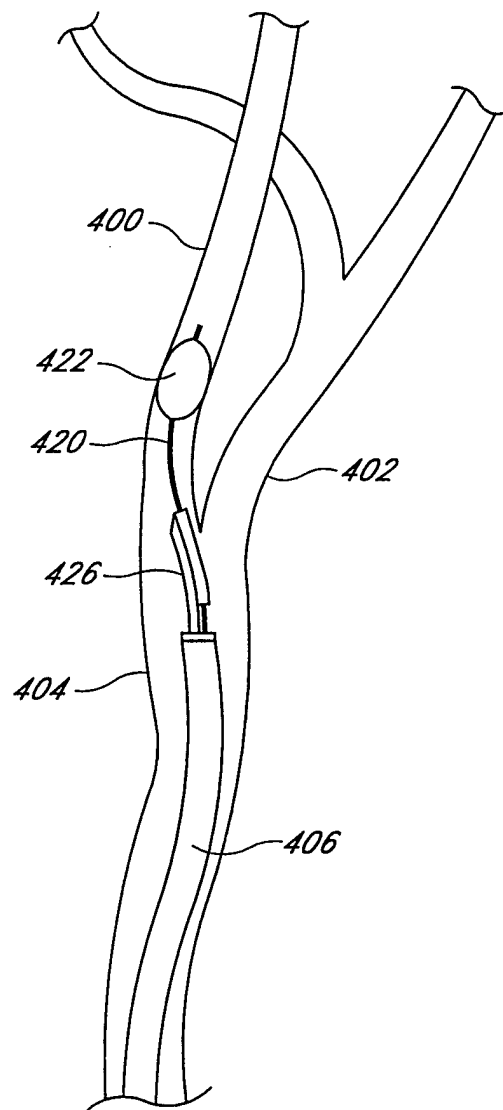

FIG. 20

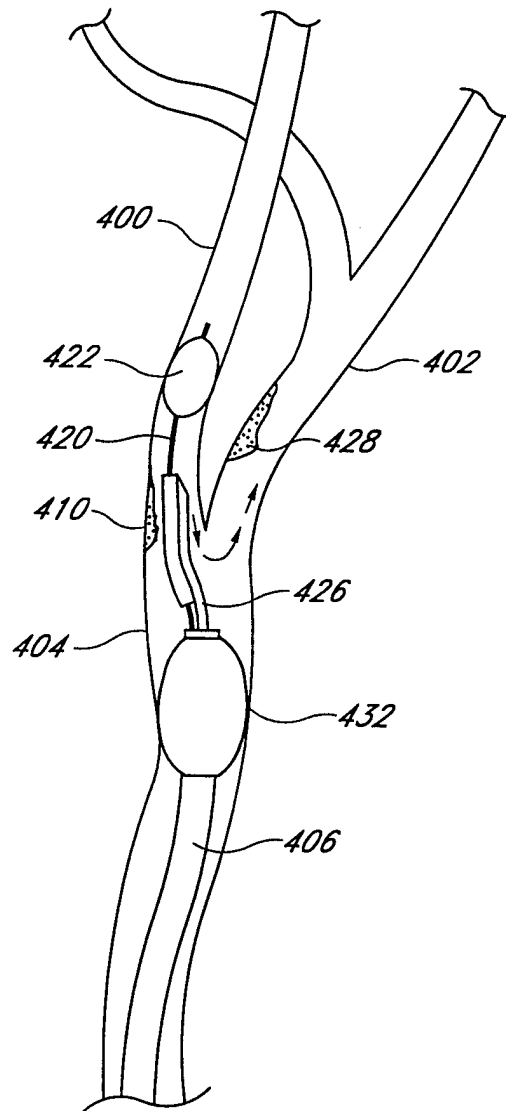

FIG. 21

INTERNATIONAL SEARCH REPORT

Inte: onal Application No
PCT/US 98/04417

A. CLASSIFICATION OF SUBJECT MATTER
IPC 6 A61B17/22 A61M25/00

According to International Patent Classification (IPC) or to both national classification and IPC

B. FIELDS SEARCHED

Minimum documentation searched (classification system followed by classification symbols)
IPC 6 A61B A61M

Documentation searched other than minimum documentation to the extent that such documents are included in the fields searched

Electronic data base consulted during the international search (name of data base and, where practical, search terms used)

C. DOCUMENTS CONSIDERED TO BE RELEVANT

Category	Citation of document, with indication, where appropriate, of the relevant passages	Relevant to claim No.
P, X	WO 97 44082 A (PERCUSURGE INC ;BAGAOISAN CELSO J (US); HA HUNG V (US); PATEL MUKU) 27 November 1997	1-3, 5
A	see the whole document	4
P, X	US 5 681 336 A (AUTH DAVID C ET AL) 28 October 1997 see the whole document	1, 2, 4, 5
X	WO 95 09024 A (TECHNOLOGY DEV CENTER) 6 April 1995	1, 2, 5
A	see the whole document	4
A	US 5 423 742 A (THERON JACQUES) 13 June 1995 see column 2, line 23 - column 3, line 34; figures 2-3F	1
	-/--	

Further documents are listed in the continuation of box C.

Patent family members are listed in annex.

° Special categories of cited documents :

- "A" document defining the general state of the art which is not considered to be of particular relevance
- "E" earlier document but published on or after the international filing date
- "L" document which may throw doubts on priority claim(s) or which is cited to establish the publication date of another citation or other special reason (as specified)
- "O" document referring to an oral disclosure, use, exhibition or other means
- "P" document published prior to the international filing date but later than the priority date claimed

- "T" later document published after the international filing date or priority date and not in conflict with the application but cited to understand the principle or theory underlying the invention
- "X" document of particular relevance; the claimed invention cannot be considered novel or cannot be considered to involve an inventive step when the document is taken alone
- "Y" document of particular relevance; the claimed invention cannot be considered to involve an inventive step when the document is combined with one or more other such documents, such combination being obvious to a person skilled in the art.
- "&" document member of the same patent family

Date of the actual completion of the international search

14 July 1998

Date of mailing of the international search report

24.07.98

Name and mailing address of the ISA

European Patent Office, P.B. 5818 Patentlaan 2
NL - 2280 HV Rijswijk
Tel. (+31-70) 340-2040, Tx. 31 651 epo nl,
Fax: (+31-70) 340-3016

Authorized officer

Jameson, P

INTERNATIONAL SEARCH REPORT

International Application No

PCT/US 98/04417

C.(Continuation) DOCUMENTS CONSIDERED TO BE RELEVANT

Category	Citation of document, with indication, where appropriate, of the relevant passages	Relevant to claim No.
A	US 5 059 178 A (YA WANG D) 22 October 1991 see column 4, line 40 - column 8, line 3; figures 1-21 <p style="text-align: center;">---</p>	1
A	US 4 964 409 A (TREMULIS WILLIAM S) 23 October 1990 see abstract; figure 1 <p style="text-align: center;">-----</p>	4

INTERNATIONAL SEARCH REPORT

International application No.
PCT/US 98/04417

Box I Observations where certain claims were found unsearchable (Continuation of item 1 of first sheet)

This International Search Report has not been established in respect of certain claims under Article 17(2)(a) for the following reasons:

1. Claims Nos.: 6-66
because they relate to subject matter not required to be searched by this Authority, namely:
Rule 39.1(iv) PCT - Method for treatment of the human or animal body by surgery
2. Claims Nos.:
because they relate to parts of the International Application that do not comply with the prescribed requirements to such an extent that no meaningful International Search can be carried out, specifically:
3. Claims Nos.:
because they are dependent claims and are not drafted in accordance with the second and third sentences of Rule 6.4(a).

Box II Observations where unity of invention is lacking (Continuation of item 2 of first sheet)

This International Searching Authority found multiple inventions in this international application, as follows:

1. As all required additional search fees were timely paid by the applicant, this International Search Report covers all searchable claims.
2. As all searchable claims could be searched without effort justifying an additional fee, this Authority did not invite payment of any additional fee.
3. As only some of the required additional search fees were timely paid by the applicant, this International Search Report covers only those claims for which fees were paid, specifically claims Nos.:
4. No required additional search fees were timely paid by the applicant. Consequently, this International Search Report is restricted to the invention first mentioned in the claims; it is covered by claims Nos.:

Remark on Protest

- The additional search fees were accompanied by the applicant's protest.
- No protest accompanied the payment of additional search fees.

INTERNATIONAL SEARCH REPORT

Information on patent family members

International Application No

PCT/US 98/04417

Patent document cited in search report		Publication date	Patent family member(s)	Publication date
WO 9744082	A	27-11-1997	AU 3071797	09-12-1997
			AU 3071897	09-12-1997
			AU 3132097	09-12-1997
			WO 9744084	27-11-1997
			WO 9744085	27-11-1997
US 5681336	A	28-10-1997	NONE	
WO 9509024	A	06-04-1995	US 5462529	31-10-1995
			AU 7846694	18-04-1995
US 5423742	A	13-06-1995	DE 8910856	30-11-1989
US 5059178	A	22-10-1991	JP 1752627	08-04-1993
			JP 2055064	23-02-1990
			JP 4038435	24-06-1992
US 4964409	A	23-10-1990	US 4953553	04-09-1990
			US 5050606	24-09-1991
			CA 2016339	11-11-1990
			EP 0397173	14-11-1990
			JP 3090166	16-04-1991
			US 5159937	03-11-1992