

(12) PATENT
(19) AUSTRALIAN PATENT OFFICE

(11) Application No. AU 200123730 B2
(10) Patent No. 774279

- (54) Title
Device for transferring a substance applied to a support tape in the form of a film to a substrate
- (51)⁷ International Patent Classification(s)
B65H 037/00
- (21) Application No: **200123730** (22) Application Date: **2001.01.08**
- (87) WIPO No: **WO01/51394**
- (30) Priority Data
- | | | |
|-----------------|-------------------|--------------|
| (31) Number | (32) Date | (33) Country |
| 10001465 | 2000.01.15 | DE |
- (43) Publication Date : **2001.07.24**
(43) Publication Journal Date : **2001.10.04**
(44) Accepted Journal Date : **2004.06.24**
- (71) Applicant(s)
Pritt Produktionsgesellschaft mbH
- (72) Inventor(s)
Ingo Bebensee; Wulf Herrmannsen; Oliver Bartling
- (74) Agent/Attorney
SPRUSON and FERGUSON,GPO Box 3898,SYDNEY NSW 2001
- (56) Related Art
US 4853074
US 3170613
US 4997512

(12) NACH DEM VERTRAG ÜBER DIE INTERNATIONALE ZUSAMMENARBEIT AUF DEM GEBIET DES PATENTWESENS (PCT) VERÖFFENTLICHTE INTERNATIONALE ANMELDUNG

(19) Weltorganisation für geistiges Eigentum
Internationales Büro



(43) Internationales Veröffentlichungsdatum
19. Juli 2001 (19.07.2001)

PCT

(10) Internationale Veröffentlichungsnummer
WO 01/51394 A1

- (51) Internationale Patentklassifikation⁷: B65H 37/00
- (21) Internationales Aktenzeichen: PCT/EP01/00127
- (22) Internationales Anmeldedatum:
8. Januar 2001 (08.01.2001)
- (25) Einreichungssprache: Deutsch
- (26) Veröffentlichungssprache: Deutsch
- (30) Angaben zur Priorität:
100 01 465.8 15. Januar 2000 (15.01.2000) DE
- (71) Anmelder (für alle Bestimmungsstaaten mit Ausnahme von US): PRITT PRODUKTIONSGESELLSCHAFT MBH [DE/DE]; Sichelstrasse 1, 30453 Hannover (DE).
- (72) Erfinder; und
(75) Erfinder/Anmelder (nur für US): BEBENSEE, Ingo [DE/DE]; Kriegerstrasse 43, 30161 Hannover (DE).
HERRMANNSEN, Wulf [DE/DE]; Rebhuhnweg 16, 30952 Ronnenberg (DE).
BARTLING, Oliver [DE/DE]; Droehnenstrasse 33, 30455 Hannover (DE).
- (74) Anwalt: MATHES, Nikolaus; Henkel Kommanditgesellschaft auf Aktien, Patente (VTP), 40191 Düsseldorf (DE).
- (81) Bestimmungsstaaten (national): AE, AG, AL, AM, AU, AZ, BA, BB, BG, BR, BY, BZ, CA, CN, CR, CU, CZ, DM, DZ, EE, GD, GE, GH, GM, HR, HU, ID, IL, IN, IS, JP, KE, KG, KP, KR, KZ, LC, LK, LR, LS, LT, LV, MA, MD, MG, MK, MN, MW, MX, MZ, NO, NZ, PL, RO, RU, SD, SG,

[Fortsetzung auf der nächsten Seite]

(54) Title: DEVICE FOR TRANSFERRING A SUBSTANCE APPLIED TO A SUPPORT TAPE IN THE FORM OF A FILM TO A SUBSTRATE

(54) Bezeichnung: GERÄT ZUM ÜBERTRAGEN EINES IN FORM EINES FILMES AUF EIN TRÄGERBAND AUFGEBRACHTEN STOFFES AUF EIN SUBSTRAT

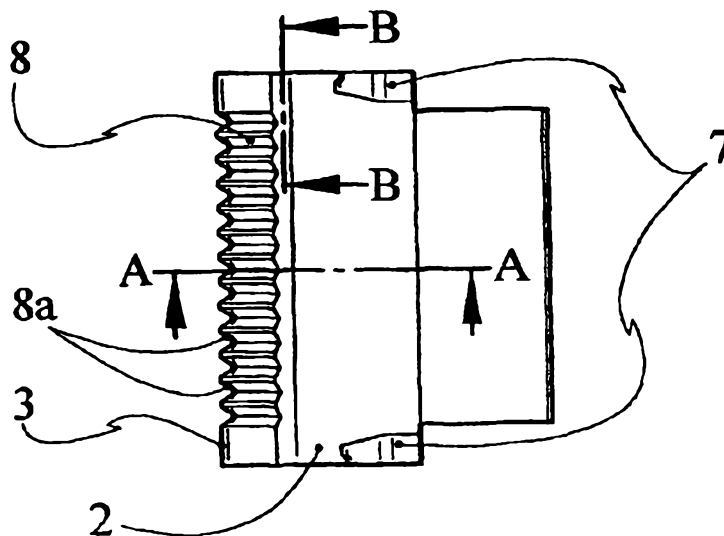

(57) Abstract: The invention relates to a device for transferring a substance that has been applied to a support tape in the form of a film, to a substrate such as a writing or drawing sheet. The device comprises a housing in which a supply reel for the film-coated support tape and an empty reel for receiving the support tape with the coating removed are located. The film-coated support tape is guided over an application base with an application edge, said support tape looping around said base. The aim of the invention is to improve the smooth running of the device and the perfect transfer of the film to the substrate while ensuring in particular, that the device remains economical to produce. To this end, the application base (1) is provided with at least one recess (8, 8a, 9) at least in the area of the underside facing towards the substrate.

[Fortsetzung auf der nächsten Seite]



SI, SK, SL, TJ, TM, TT, TZ, UA, UG, US, UZ, VN, YU,
ZA, ZW.

(84) **Bestimmungsstaaten (regional):** ARIPO-Patent (GH, GM, KE, LS, MW, MZ, SD, SL, SZ, TZ, UG, ZW), eurasisches Patent (AM, AZ, BY, KG, KZ, MD, RU, TJ, TM), europäisches Patent (AT, BE, CH, CY, DE, DK, ES, FI, FR, GB, GR, IE, IT, LU, MC, NL, PT, SE, TR), OAPI-Patent (BF, BJ, CF, CG, CI, CM, GA, GN, GW, ML, MR, NE, SN, TD, TG).

Veröffentlicht:

- mit internationalem Recherchenbericht
- vor Ablauf der für Änderungen der Ansprüche geltenden Frist; Veröffentlichung wird wiederholt, falls Änderungen eintreffen

Zur Erklärung der Zweibuchstaben-Codes, und der anderen Abkürzungen wird auf die Erklärungen ("Guidance Notes on Codes and Abbreviations") am Anfang jeder regulären Ausgabe der PCT-Gazette verwiesen.

(57) **Zusammenfassung:** Ein Gerät zum Übertragen eines in Form eines Filmes auf ein Trägerband aufgebracht Stoffes auf ein Substrat, wie ein Schreib- oder Zeichenblatt, mit einem Gehäuse, in dem eine Vorratsspule für das filmbeschichtete Trägerband und eine Leerspule zur Aufnahme des entschlitzten Trägerbandes angeordnet sind, wobei das filmbeschichtete Trägerband über einen Auftragsfuß mit Auftragskante geführt ist, welcher vom Trägerband umschlungen ist, soll so verbessert werden, dass mit möglichst einfachen Mitteln unter besonderer Berücksichtigung einer wirtschaftlichen Herstellbarkeit die Leichtgängigkeit und die einwandfreie Übertragung des Filmes auf das Substrat verbessert wird. Dies wird dadurch erreicht, dass der Auftragsfuß (1) wenigstens im Bereich seiner dem Substrat zugewandten Unterseite mit wenigstens einer Ausnehmung (8, 8a, 9) versehen ist.

Device for transferring a substance applied to a support tape
in the form of a film to a substrate

The invention relates to a device for transferring to a substrate, such as a writing or drawing sheet, a substance applied in the form of a film to a carrier tape, comprising a housing in which a storage reel for the film-coated carrier tape and an empty reel for receiving the carrier tape with the coating removed are arranged, wherein the film-coated carrier tape is guided over an applicator foot with an applicator edge, around which the carrier tape is looped.

Hand devices of that kind for transferring a film (for example, adhesive, covering material, marking colorant, etc.) are known. In that case different realisations of the designs of the applicator foot are known in pursuit of easy motion and good capability of transfer of the film to the substrate. Thus, the applicator foot can, for example, be equipped with an applicator roller which preferably has a rubber-elastic running surface. However, since the outer diameter of an applicator roller appropriate to the function cannot be kept as small as desired, because good brushing against the substrate requires a minimum thickness for the elastic running ring and rotational mobility presupposes a sufficient difference between stub axle and outer diameter, such a roller has disadvantages. Accordingly, most solutions for the applicator foot comprise an applicator strip which has advantages relative to an applicator roller, since a sharper unwinding of the carrier tape is possible in the transfer phase, whereby the detached portion after completed transfer has less tendency to formation of a wavy edge. Thereagainst, a disadvantage relative to a solution with an applicator roller is that in the case of the applicator strip the carrier tape is guided over this with a friction couple, which depending on the respective quality of the carrier tape can lead to an undesired heavy motion.

A device according to category is known from, for example, the specification US-4 853 074 A. In this known apparatus there is provided, at the end of the applicator strip facing the carrier film, apart from the presser edge a heel edge which is arranged parallel thereto and which separately projects through a depression or recess of this and is similarly rounded off, the heel edge having a substantially smaller radius of curvature than the presser edge. The recess there in that case merely serves the purpose of forming a spacing between two elevations. The "ironing-on" of the torn-off edge of the adhesive to the substrate shall thereby be improved. The disadvantage of this solution is, however, that in principle it does not improve transfer of the film to the substrate, but merely ensures that at the start of the transfer process the film is indeed transferred to the substrate.

A device according to the category is also known from, for example, US-A-5 430 904. In this device the applicator foot in the region looped around by the carrier tape is provided with a slide element of a friction-reducing rubber-like material which is fastened to the applicator foot. This slide element is to serve the purpose of achieving a faultless transfer of the film to the substrate. However, it has proved that the easy motion of the device and the transfer of the film to the substrate is still worthy of improvement.

Moreover, another device according to the category is known from EP 0 360 045 A2. In this device the applicator foot has, adjacent to a rigid applicator strip at the free end, an end region which is capable of springing away relative to the applicator strip and which defines a presser edge and consists of mutually adjacent portions able to resiliently spring out substantially independently of one another perpendicularly to the longitudinal centre plane relative to the applicator strip, but formed to be non-yielding in the direction of this longitudinal centre plane. These end regions in that case are preferably formed from resilient tongues disposed adjacent to one another, wherein, however, each tongue is deflectable quite independently of the adjacent tongues. A good adaptation to uneven substrates is indeed possible with such an applicator foot, but an applicator foot of that kind with several tongues arranged adjacent to one another is relatively costly to produce.

The object of the invention is accordingly to so improve a device according to category that the easy motion and faultless transfer of the film to the substrate are improved by simplest possible means with particular consideration of economic capability of manufacture.

According to the invention there is provided a device for transferring to a substrate, such as a writing or drawing sheet, a substance applied in the form of a film to a carrier tape, comprising a housing in which a storage reel for the film-coated carrier tape and an empty reel for receiving the carrier tape with the coating removed are arranged, wherein
5 the film-coated carrier tape is guided over an applicator foot with an applicator edge, around which the carrier tape is looped, wherein the applicator foot is provided at least in the region of its underside facing the substrate with at least one recess which extends into the region of the applicator edge, wherein the at least one recess extends in the conveying direction of the carrier tape.

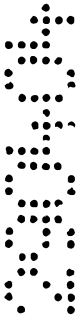

In departure from known devices of this kind, the underside of the applicator foot thus does not have a flat surface in the region of the applicator edge or in the region adjoining the applicator edge, but is provided with recesses, whereby the surface of the applicator foot in this region is greater than the support area of the carrier tape on the applicator foot, i.e. the contact area between the applicator foot and the carrier tape is very small. Substantially improved slide properties thereby result, in particular hardly any stretching in the material layer (for example, adhesive) to be transferred occurs, the carrier tape does not slip through during use and running properties remain stable until the tape end. In addition, blockages due to high friction do not occur. The manufacture of the device is not thereby made difficult, since the (injection-moulding) tool has to be rebuilt or modified only once.

In a particularly advantageous embodiment it is provided that the at least one recess extends into the region of the applicator edge. Since the carrier tape during use is pressed against the applicator foot particularly in the region of the applicator edge, it is especially advantageous if the contact area is also reduced in this region by the recesses.

In order to keep the contact area between the carrier tape and the applicator foot as small as possible, it is advantageous to provide several recesses arranged adjacent to one another and extending from the applicator edge in the conveying direction of the carrier tape.

The recesses can in that case be arranged parallelly and they can also be arranged to run conically towards the applicator edge, other geometric formations also being possible.

Additionally or alternatively at least one recess can be arranged transversely to the conveying direction in front of the applicator edge as seen in the conveying direction and can be formed as a collecting groove for film coating residues. Residues not transferred to the substrate can be caught by this collecting groove and do not impair the functional capability of the device; in particular, these residues do not pass into the region of the empty reel. The easy mobility of the device is thus further improved.

In a further advantageous embodiment that the applicator foot can also be provided with recesses on its upper side.

The invention is explained in more detail by way of example in the following by reference to the drawing, in which:

- Fig. 1 shows, in perspective illustration, an applicator foot of a device according to the invention,
- Fig. 2 shows a view from below of the applicator strip of the applicator foot,
- Fig. 3 shows a view from the front of the applicator strip in an arrangement disposed overhead relative to the use position,
- Fig. 4 shows a section according to the line A-A in Fig. 2,
- Fig. 5 shows a section according to the line B-B in Fig. 2,
- Fig. 6 shows a view from the side of the illustration according to Fig. 3,
- Fig. 7 shows a view from below of a modified applicator strip of the applicator foot and
- Fig. 8 shows a section according to the line A-A in Fig. 7.

In Fig. 1 there are illustrated - of a device according to the invention for transferring to a substrate a substance applied in the form of a film to a carrier tape - only the parts which are of significance for the invention, namely substantially only an applicator foot generally denoted by 1. This applicator foot 1 is equipped with an applicator strip 2 with a front applicator edge 3, around which is guided, over the applicator strip 2, a coated carrier tape 4 coming from a storage reel (not illustrated) of the device. After transfer of the coating 5 to a substrate it is guided back as empty tape 6 to a winding-up reel (not illustrated) of the device, the reel being arranged in the housing (not illustrated) of the device.

Tape guide ears 7, between which the carrier tape 4 coming from the storage reel of the device is guided, are provided in usual manner on both sides at the underside of the applicator strip 2 at the end seen in conveying direction, i.e. opposite the applicator edge 3.

According to the invention it is now provided that the applicator foot 1 is provided at the least in the region of its underside facing the substrate, i.e. at the side having the tape guidance ears 7, and in the region of its applicator strip 2 with, preferably, several recesses 8 which are arranged substantially in conveying direction and which in the case of the embodiment are disposed adjacent and parallel to one another and parallel to the conveying direction. These recesses 8 in that case preferably extend into the vicinity of the applicator edge 3, those regions of the recesses being denoted by 8a. These notch-shaped recesses 8 or 8a have the consequence that the applicator strip 2 in this region has a substantially larger surface than the surface of the carrier tape 4, so that the carrier tape 4 bears against the applicator strip 2 only by very small contact areas.

The recesses 8 and 8a can in principle have any desired shape or arrangement and the number of recesses 8 is in principle as desired, being obviously dependent on the size of the applicator strip 2. By virtue of these notch-shaped recesses 8, 8a not only a small contact area for the carrier tape 4 is given, but a good capability of transfer to uneven substrates is also guaranteed.

In an alternative form of embodiment, which is not illustrated, the recesses 8 can also be formed to run conically towards the applicator edge 3, i.e. the individual notch-shaped recesses 8 are then arranged to be non-parallel, but to run forwardly to a tip or conically preferably symmetrically relative to the centre axis. The form of recesses 8 illustrated in, in particular, Fig. 5 is in fact preferably notch-shaped, but obviously other geometric designs are also possible.

A further form of embodiment of the invention is illustrated in Figs. 7 and 8. In distinction from the form of embodiment according to Figs. 1 to 6, in this form of embodiment it is additionally provided that at least one recess 9 is arranged transversely to the conveying direction in front of the applicator edge 3 as seen in the conveying direction and is formed as a collecting groove for film coating residues. Film coating residues can then accumulate in this collecting groove 9 and do not pass into the region of the empty reel, so that a faultless winding-up of the empty tape 6 is guaranteed and the easy motion of the device is ensured.

The invention is obviously not restricted to the illustrated examples of embodiment. Further embodiments are possible without departing from the basic concepts. Even if this is not illustrated in the drawings, it can also be provided in accordance with the invention

that the applicator foot 1 has only a recess 9 transverse to the conveying direction, whilst the applicator strip 2 is otherwise constructed to be flat, i.e. does not have any recesses 8, 8a.

The claims defining the invention are as follows:

1. A device for transferring to a substrate, such as a writing or drawing sheet, a substance applied in the form of a film to a carrier tape, comprising a housing in which a storage reel for the film-coated carrier tape and an empty reel for receiving the carrier tape with the coating removed are arranged, wherein the film-coated carrier tape is guided
5 over an applicator foot with an applicator edge, around which the carrier tape is looped, wherein the applicator foot is provided at least in the region of its underside facing the substrate with at least one recess which extends into the region of the applicator edge, wherein the at least one recess extends in the conveying direction of the carrier tape.
- 10 2. A device according to claim 1, wherein several recesses arranged adjacent to one another are provided.
3. A device according to claim 2, wherein the at least one recess extends into the region of the applicator edge.
4. A device according to claim 2 or 3, wherein the recesses are arranged to run
15 conically towards the applicator edge.
5. A device according to any one of claims 1 to 4, wherein at least one additional recess is arranged transversely to the conveying direction in front of the applicator edge as seen in conveying direction and is formed as a collecting channel for film coating residues.
- 20 6. A device according to any one of claims 1 to 5, wherein the applicator foot is also provided with recesses on its upper side.
7. A device for transferring a substance applied in the form of a film to a carrier tape substantially as hereinbefore described with reference to the accompanying drawings.

Dated 28 April, 2004

Pritt Produktionsgesellschaft mbH

**Patent Attorneys for the Applicant/Nominated Person
SPRUSON & FERGUSON**

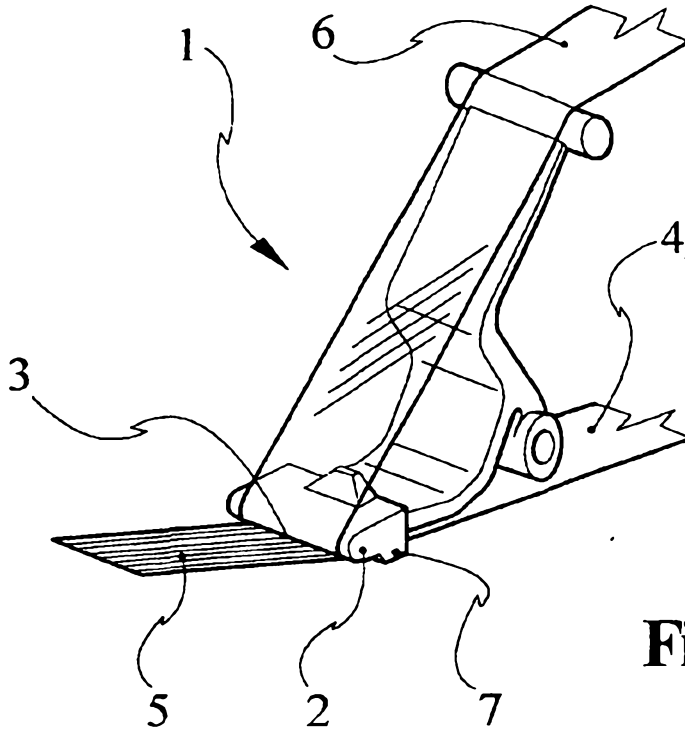

Fig. 1

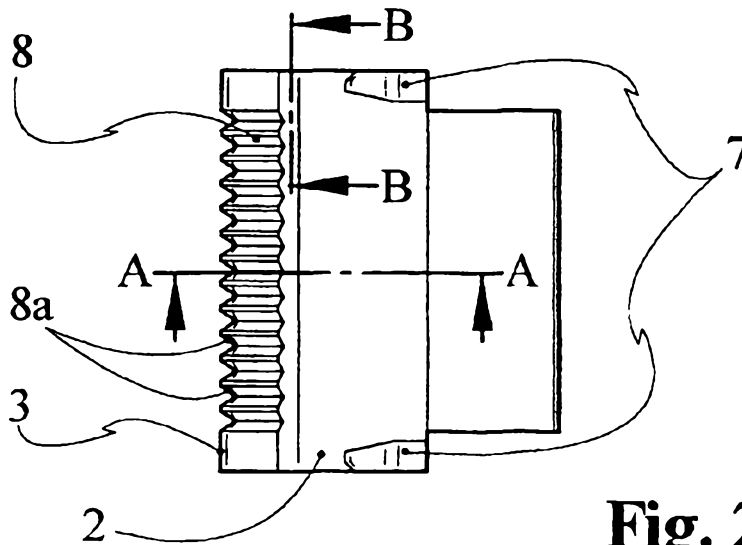

Fig. 2

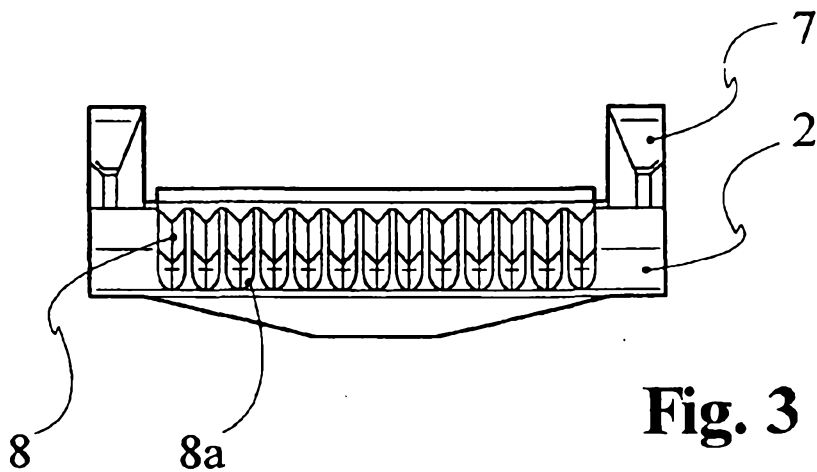

Fig. 3

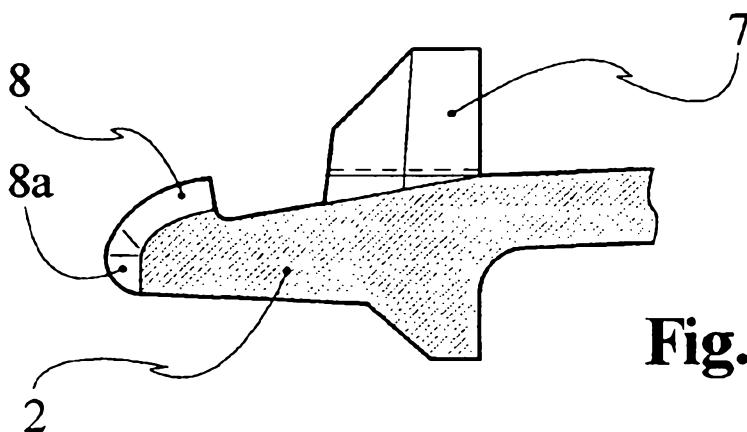

Fig. 4

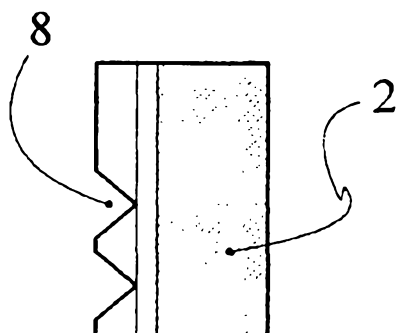

Fig. 5

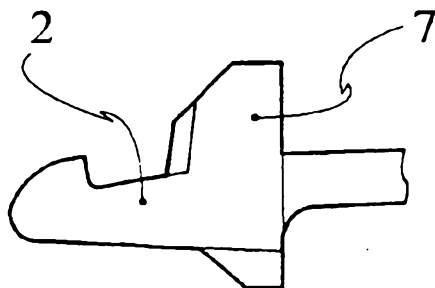

Fig. 6

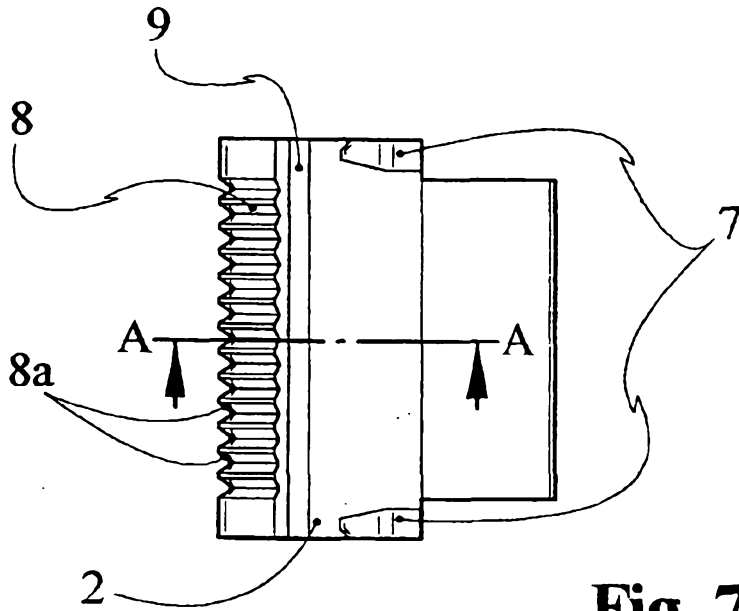

Fig. 7

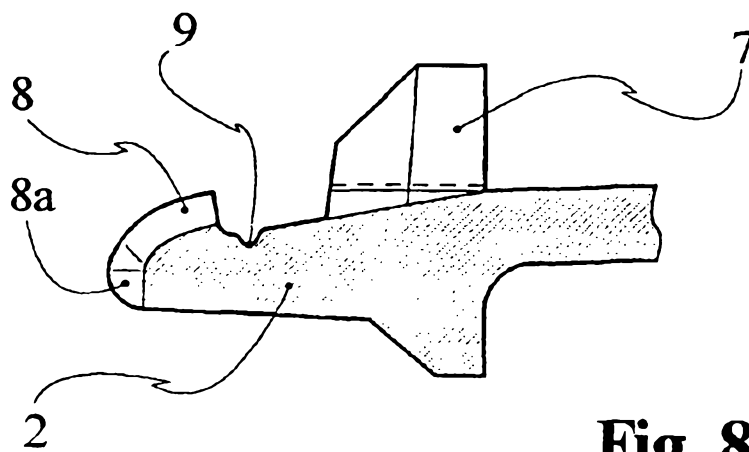

Fig. 8