

597814

FORM APPLICATION ACCEPTED AND AMENDMENTS
15.3.90.
ALLOWED

SPRUSON & FERGUSON*

COMMONWEALTH OF AUSTRALIA

PATENTS ACT 1952

APPLICATION FOR A STANDARD PATENT

James E. Klosterman, of 466 Chatham Drive, Dayton, Ohio, 45429, UNITED STATES OF AMERICA, hereby apply for the grant of a standard patent for an invention entitled:

Simplified Adjustable Ski Binding Structure

which is described in the accompanying complete specification.

The address for service is:-

Spruson & Ferguson
Patent Attorneys
Level 33 St Martins Tower
31 Market Street
Sydney New South Wales Australia

DATED this EIGHTH day of APRIL 1988

James E. Klosterman

By:

M. J. Anderson

Registered Patent Attorney

TO: THE COMMISSIONER OF PATENTS
OUR REF: 55390
S&F CODE: 56150

LODGED AT SUB-OFFICE
- 8 APR 1988
Sydney

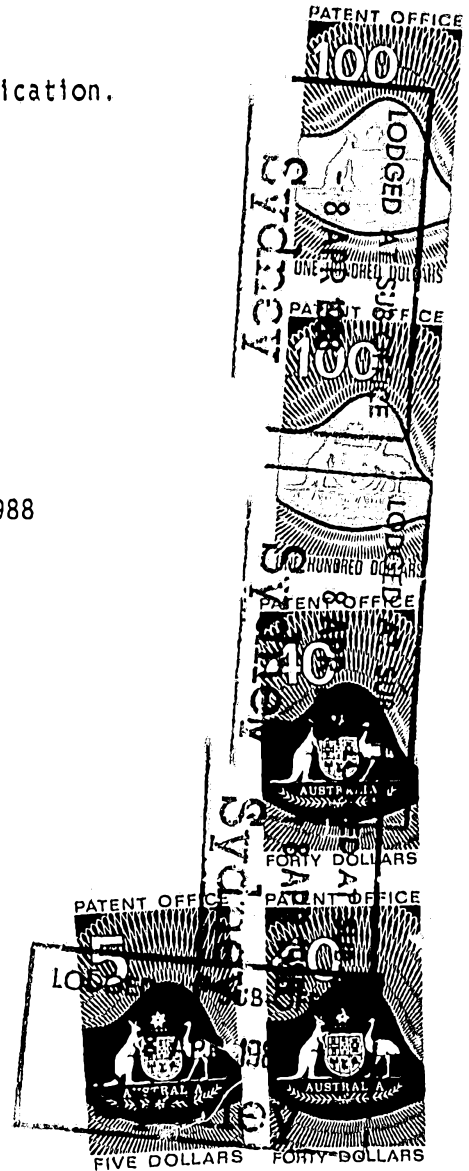

5845/2

285/0

DECLARATION IN SUPPORT OF AN APPLICATION
FOR A PATENT OR PATENT OF ADDITION.

Full name of
Applicant.

In support of the application made by James E. Klosterman

for a ~~patent~~ ^{patent of addition} for an invention entitled

Simplified Adjustable Ski Binding Structure

Full name and address
of Declarant.

I, James E. Klosterman of 466 Chatham Drive
Dayton, Ohio 45429
United States of America

do solemnly and sincerely declare as follows:-

I am the applicant for the ~~patent.~~
~~1. I am the applicant for the patent of addition.~~

(or, in the case of an application by a body corporate)

~~1. I am authorised by~~

~~the applicant for the patent of addition to make this declaration on its behalf.~~

2. I am the actual inventor of the invention.

(or, where a person other than the inventor is the applicant)

Full name and address
of Inventor(s).

2.

~~of~~

~~is the actual inventor of the invention and the facts upon which the applicant is/are entitled to make the application are as follows:-~~

Declared at Dayton, Ohio this 25th day of March 19 88.

James E. Klosterman
Signature of Declarant.

James E. Klosterman
SPRUSON & FERGUSON

To:
The Commissioner of Patents,

(12) PATENT ABRIDGMENT (11) Document No. AU-B-14401/88
(19) AUSTRALIAN PATENT OFFICE (10) Acceptance No. 597814

- (54) Title
SIMPLIFIED ADJUSTABLE SKI BINDING STRUCTURE
- International Patent Classification(s)
(51)^a A63C 009/04
- (21) Application No. : 14401/88 (22) Application Date : 08.04.88
- (43) Publication Date : 30.11.89
- (44) Publication Date of Accepted Application : 07.06.90
- (71) Applicant(s)
JAMES E. KLOSTERMAN
- (72) Inventor(s)
JAMES E. KLOSTERMAN
- (74) Attorney or Agent
SPRUSON & FERGUSON
- (57) Claim

12. ^A ~~The method of producing a ski binding~~
structure for attachment to a ski and for receiving a
boot or the like comprising:

forming a flat sheet of material into an attach-
ment portion, a pair of side portions, and an enclosure
portion, separating the side portions from the attachment
portions, with the enclosure portion attached to the
attachment portion,

followed by moving the side portions to positions
one upon the other and upon the attachment portion, where-
by the side portions cover the attachment portion, and
folding the enclosure portion with respect to the attach-
ment portion and to a position which partially encompasses
the attachment portion and the side portions to form
a receptacle which is adapted to receive a portion of
a boot or the like.

21. Ski binding structure for retaining foot-
wear of a skier comprising a sheet of material provided
with an attachment portion, the attachment portion in-
cluding means for attachment to a ski, a pair of side
portions, and an enclosure portion, the side portions
and the attachment portion being adapted to be substan-

tially horizontal, the side portions being positioned one upon the other and above the attachment portion, the enclosure portion extending upwardly from the attachment portion and from the side portions, the enclosure portion partially encompassing the side portions and the attachment portion, the attachment portion and the side portions and the enclosure portion thus forming a receptacle to receive footwear as the footwear is positioned above the side portions and the attachment portion and as a part of the footwear is partially encompassed by the enclosure portion, and means for attaching the attachment portion to a ski.

30. Ski binding structure for attachment to a snow ski, the ski binding structure being adapted to receive a ski boot or the like, comprising:

a receptacle member adapted to receive at least a portion of a ski boot or the like including a single piece of foldable material having a plurality of portions which are folded one with respect to the other, there being a bottom portion and an enclosure portion, the bottom portion being adapted to be substantially horizontal, the enclosure portion extending upwardly from the bottom portion as the enclosure portion encompasses at least a part of the bottom portion, means for maintaining the enclosure portion in an upwardly extending position with respect to the bottom portion, whereby a receptacle is formed to receive a part of a ski boot or the like, as a part of the ski boot is positioned upon the bottom portion and is partially encompassed by the enclosure portion, and means for attachment of the bottom portion to a ski.

FORM 10

COMMONWEALTH OF AUSTRALIA

PATENTS ACT 1952

COMPLETE SPECIFICATION

59 78 14

(ORIGINAL)

FOR OFFICE USE:

Class Int Class

•••••
•••••
•••••
•••••
•••••
•••••
•••••
•••••
•••••
•••••

Complete Specification Lodged:
Accepted:
Published:

This document contains the amendments made under Section 49 and is correct for printing.

Priority:

Related Art:

Name and Address
of Applicant:

James E. Klosterman
466 Chatham Drive
Dayton Ohio 45429 UNITED STATES OF AMERICA

Address for Service:

Spruson & Ferguson, Patent Attorneys
Level 33 St Martins Tower, 31 Market Street
Sydney, New South Wales, 2000, Australia

Complete Specification for the invention entitled:

Simplified Adjustable Ski Binding Structure

The following statement is a full description of this invention, including the best method of performing it known to me/us

SIMPLIFIED ADJUSTABLE SKI BINDING STRUCTURE

Abstract of The Disclosure

A simplified adjustable ski binding structure which includes a base section (10) (130) which can be formed from a single sheet of material. The sheet of material which forms the base section (10) (130) has portions (28) (32) (40) (132) (138) (146) (156) which are folded and which are angularly moved to form a heel section. An attachment portion (16) (116) is attached to the heel section. In one embodiment the attachment portion (16) is integral with the heel section. In another embodiment the attachment portion (116) is attached by a fastening member (180) to the heel section. The attachment portion (16) (116) has a series of apertures by which the attachment portion can be adjustably attached to a ski to receive a small boot or a large boot or a boot intermediate in size.

Background of The Invention

In order for a person to use a pair of skis a ski binding structure is attached to each ski and the ski binding structure is adapted to receive the person's
5 ski boot or shoe.

The ski binding structure must snugly fit the boot. Conventionally, only the forward part of the ski binding structure is attached to a ski and permits raising of the heel of the boot and the heel portion
10 of the ski binding structure.

A problem has existed with regard to a ski binding structure for children. Of course, a child's foot grows and requires larger boots. In the past, in order to provide a ski binding structure which snugly
15 fits a child's boot, it has been necessary periodically to purchase new ski binding structures as the child's foot grows and as the child wears larger boots. Naturally significant expense and trouble are involved as it is necessary to periodically obtain a new pair of ski binding
20 structures for a child as the child grows.

~~It is an object of this invention to provide a ski binding structure which is adjustable in size and which may be used by a child when the child's boots are relatively small and which can be used by the child as
25 the child grows and wears larger and larger boots.~~

~~Another object of this invention is to provide a ski binding structure which is adjustable in size and which can be used by persons having any one of a plurality of boot sizes.~~



It is the object of the present invention to provide an improved ski binding structure for attachment to a snow ski which overcomes at least one of the problems and/or disadvantages of the prior art.

In one broad form the present invention provides a ski binding structure for attachment to a snow ski, the ski binding structure being adapted to receive a ski boot or the like, comprising:

5 a receptacle member adapted to receive at least a portion of a ski boot or the like including a single piece of material having a plurality of portions which are folded one with respect to the other, there being a
10 bottom portion, a pair of side portions and an enclosure portion, the side portions being separated from the bottom portion by cut lines, the enclosure portion being joined to the bottom portion and to the side portions by fold lines, the side portions being positioned one upon the other and positioned upon the bottom portion, the enclosure portion
15 extending upwardly from the bottom portion and from the side portions, the enclosure portion encompassing at least part of the side portions and the bottom portion, whereby a receptacle is formed to receive a part of a ski boot or the like, as a part of the ski boot is positioned upon one of the side portions and above the side portions and above the bottom portion, and
20 as a part of the ski boot is partially encompassed by the enclosure portion, and means for attachment of at least one of the portions to a ski.

A further broad form of the present invention provides a method of producing ski binding structure for attachment to a ski and for receiving a ski boot or the like, comprising:

25 forming a single sheet of material into a plurality of portions, including an attachment portion, a bottom portion, a pair of side portions including a first side portion and a second side portion, forming a cut line between the attachment portion and the first side portion, forming a cut line between the attachment portion and the second side portion,
30 forming an enclosure portion, forming a fold line between the enclosure portion and the first side portion and forming a fold line between the enclosure portion and the bottom portion and forming a fold line between the enclosure portion and the second side portion, and forming a fold line between the enclosure portion and the attachment portion,



moving the side portions to positions one upon the other and upon the bottom portion, folding the enclosure portion to a position which partially encompasses the attachment portion and the side portions, the formation of the side portions and the attachment portion and the enclosure portion thus forming a receptacle for a portion of a ski boot or the like.

Preferred forms of the present invention will now be described by way of example with reference to the accompanying drawings, wherein:

FIG. 1 is a plan or lay-out view showing a single piece of material from which a base portion of ski binding structure is constructed in accordance with this invention.

FIG. 2 is a fragmentary perspective view, illustrating a step in formation of the single piece of material into a base portion of ski binding structure.

FIG. 3 is a fragmentary perspective view illustrating another step in formation of the single piece of material into a base portion of ski binding structure.

FIG. 4 is a perspective view, with parts broken away and shown in section, of the one-piece base portion and illustrating a securing member combined with the base portion.

FIG. 5 is a lay-out view or plan view of a one-piece toe portion of ski binding structure of this invention.

FIG. 6 is a fragmentary perspective view showing the toe portion of the ski binding structure in formation to receive a toe of a boot and including an attachment member joined to the toe portion.

STA/10655b



FIG. 7 is a fragmentary perspective exploded view showing the ski binding structure of FIGS. 1-6 and illustrating attachment of the ski binding structure to a ski.

5 FIG. 8 is a fragmentary perspective view illustrating a pair of ski binding structures constructed according to this invention and attached to a pair of skis and illustrating use thereof as a right boot binding structure and as a left boot binding structure.

10 FIG. 9 is a fragmentary plan view, with parts shown broken away, of a ski binding structure of this invention, illustrating attachment thereof to a ski and adjusted to receive a relatively large boot.

15 FIG. 10 is a plan view, similar to FIG. 9, illustrating attachment of the ski binding structure to a ski and adjusted to receive a relatively small boot.

 FIG. 11 is a plan view or lay-out view showing a portion of another embodiment of the ski binding structure of this invention.

20 FIG. 12 is a plan view or lay-out view showing another portion of the embodiment of the ski binding structure of FIG. 11.

25 FIG. 13 is a fragmentary perspective exploded view showing the embodiment of FIGS. 11 and 12 and illustrating attachment thereof to a ski.

 FIG. 14 is a plan view or lay-out view of a piece of material adapted to form a toe portion of the ski binding structure of this invention shown in FIG. 13.

30 FIG. 15 is a fragmentary perspective view of the piece of material of FIG. 14, formed into a toe portion of the ski binding structure which is shown in FIGS. 13 and 14 and including a securing member.

Detailed Description of The Invention

The preferred embodiment of this invention is shown in the lay-out view of FIG. 1. This figure shows a single sheet of material which is adapted to be formed into a ski binding base 10. The single sheet of material, may comprise a sheet of plastics material, or leather material or any other reasonably flexible and sturdy material. The base 10 has an elongate attachment portion or bottom portion 16. The attachment portion or bottom portion 16 has an end part 20 and a connection part 22. Between the end part 20 and the connection part 22, the attachment portion 16 is provided with a series of pairs of apertures 24.

A cut line 26 separates the connection part 22 of the attachment portion 16 from a flap portion 28. A cut line 30 separates the connection part 22 from a flap portion 32.

A fold line 36 separates the flap portion 28 from an elongate flap portion 40. A fold line 41 separates the connection part 22 of the elongate attachment portion 16 from the elongate flap portion 40. A fold line 43 separates the elongate flap portion 40 from the flap portion 32.

Notches 42 are shown between the cut line 26 and the fold line 36 and between the cut line 30 and the fold line 43.

The elongate attachment portion 16 is provided with a pair of slots 44 adjacent the connection part 22 of the attachment portion 16. The slots 44 are shown as being substantially parallel to each other and substantially parallel to the longitudinal axis of the attachment portion 16.

The flap portion 28 has a pair of slots 46 which are shown as being substantially normal to the slots 44. The flap portion 32 has a pair of slots 48

which are shown as being normal to the slots 44 and are shown as being in alignment with the slots 46 of the flap portion 28.

The elongate flap portion 40 has a slot 50
5 and a slot 52, which are shown as being in alignment, one with the other, and adjacent the fold lines 36 and 43, respectively. The slot 50 is shown as being in lateral alignment with the slots 46 of the flap portion 28. The slot 52 is shown as being in lateral alignment with
10 the slots 48 of the flap portion 32.

The elongate flap portion 40 is also shown
as having a slot 56 and a slot 58. The slots 56 and
58 are shown spaced from the slots 50 and 52, respec-
tively, and are at angles with respect to the slots 50
15 and 52.

As illustrated in FIGS. 2, 3, and 4, the flap
portions 28, 32, and 40 are movable with respect to the
elongate attachment portion 16. With the attachment
portion 16 maintained horizontal, the flap portion 40
20 is moved to a vertical position by folding along the fold lines 36, 41, and 43 as illustrated in FIG. 2. Then as the flap portion 32 is maintained horizontal, the flap portion 32 is moved through substantially a right angle, as illustrated by an arrow 59 in FIG. 2
25 to a position immediately above the connection part 22 of the attachment portion 16, as shown in FIG. 2. In this position of the flap portion 32, the slots 48 of the flap portion 32 are immediately above and in alignment with the slots 44 of the connection part 22 of the attach-
30 ment portion 16. Then, as the flap portion 28 is maintained horizontal, the flap portion 28 is moved through substantially a right angle, as illustrated by an arrow 61 in FIG. 3 to a position immediately above the flap portion 32, as illustrated in FIG. 3. In this position
35 of the flap portion 28, the slots 46 of the flap portion 28 are immediately above and in alignment with the slots

48 of the flap portion 32 and above and in alignment with the slots 44 of the connection part 22 of the attachment portion 16.

5 This formation of the flap portions 28, 32, and 40 and the attachment portion 16 is shown in FIG. 3 as comprising a heel receiving receptacle. In this formation the connection portion 22, and the flap portions 28 and 32 serve as a heel support region, and the flap portion 40 serves as a heel enclosure region.

10 Then, as illustrated in FIG. 4, a securing member, such as a strap 60, is inserted through the slot 58 of the flap portion 40 and then through the slot 52 of the flap portion 40. Then the strap 60 is extended to the exterior of the flap portion 40 and upwardly through
15 one of the slots 44 of the connection portion 22, then through one of the slots 48 of the flap portion 32, and then through one of the slots 46 of the flap portion 28. Then, as shown in FIG. 4, the strap 60 is extended across the flap portion 28 and is extended downwardly
20 through one of the slots 46 of the flap portion 28, then through one of the slots 48 of the flap portion 32, and then through one of the slots 44 of the connection portion 22. Then the strap 60 is extended to a position below the connection part 22 of the attachment portion 16.
25 The strap 60 is then extended to a position exterior of the flap portion 40 and then into the slot 50 of the flap portion 40 and then outwardly through the slot 56 of the flap portion 40, as illustrated in FIG. 4.

30 Insertion of the strap 60 has been described with regard to a left ski. With regard to a right ski, the strap 60 is inserted in a reverse manner.

As illustrated in FIG. 7, the base 10 is thus prepared for attachment to a ski 64. However, prior to attachment of the base 10 to the ski 64, a toe section
35 66 is formed in the manner illustrated in FIGS. 5 and 6. As shown in FIGS. 5 and 6, the toe section 66 is

formed from a single sheet of material, such as the material from which the base 10 is formed. The toe section 66, as shown in FIG. 5, is elongate, with spaced-apart fold lines 68 and 70. The fold lines 68 and 70 separate 5 the toe section 66 into a flap portion 72 and a flap portion 74, and a flap portion 76. The flap portion 72 has a slot 78 and the flap portion 76 has a slot 80. The flap portion 74 has a plurality of apertures 82.

The flap portions 72 and 76 are folded along 10 the fold lines 68 and 70, respectively, and positioned angularly with respect to the flap portion 74, as illustrated in FIG. 6. Then a securing member, such as a strap 84, is inserted through the slot 78 of the flap portion 72 and through the slot 80 of the flap portion 15 76, as shown in FIG. 6.

Then, as illustrated in FIG. 7, the toe section 66 is placed above the attachment portion 24 of the base 10. Then fastener members, such as screws 90, are inserted through the apertures 82 of the flap portion 74, 20 and through apertures 24 in the attachment portion 16 of the base 10. Then the screws 90 are inserted into holes 95 to attach the attachment portion 16 to the ski 64. Thus, the toe section 66 and the attachment portion 16 of the base 10 are attached to the ski 64.

25 FIG. 8 shows portions of a pair of skis 64 and 94, with the ski 64 serving as a left ski and the ski 94 serving as a right ski. This figure shows a buckle 96 attached to the strap 60 of the ski binding structure which is attached to the left ski 64 and a buckle 98 30 attached to a strap 99 of the ski binding structure which is attached to the right ski 94. The strap 84 of the toe section 66 of the left ski 64 has a buckle 100, and a strap 102 of the toe section of the right ski 94 has a buckle 106. Therefore, the buckles 96, 98, 100, and 35 106 are on the outside parts of the ski binding structures, so that they do not interfere with ski action. Thus,

ski binding structure of this invention is readily adapted for use with either a right boot and ski or a left boot and ski. Thus, the skis 64 and 94 are prepared for ski activity, as the heel portion of a person's boot is positioned within the flap portions 28, 32 and 40, and as the toe portion of a person's boot is positioned within the toe sections 66 of the skis 64 and 94.

As illustrated, the apertures 24 along the length of the elongate portion 16 are adapted to have a toe section 66 attached thereto, to accommodate a boot of any size between a relatively small size and a relatively large size. As illustrated in FIG. 9, the toe section 66 can be attached adjacent the end part 20 of the attachment portion 16 of the base 10. Thus, a relatively large shoe or boot is accommodated. FIG. 10 shows the toe section 66 attached to the attachment portion of the base 10 adjacent the flaps 28, 32, and 40. Thus, a relatively small shoe or boot is accommodated.

FIGURES 11-15

Figures 11-15 illustrate another embodiment of the ski binding structure of this invention.

FIG. 11 is a lay-out view which shows an elongate attachment portion or bottom portion 116 which has an end part 120 and a connection part 122. The elongate attachment portion 116 is provided with a series of pairs of apertures 124. The connection portion 122 is provided with a pair of slots 126.

FIG. 12 is a lay-out view which shows a heel section 130 which has a connection flap portion 132 which is provided with a pair of slots 134. A cut line 136 separates the connection flap portion 132 from flap portion 138. The flap portion 138 has a pair of slots 140. A cut line 144 separates the flap portion 132 from a flap portion 146. The flap portion 146 has a pair of slots 148. A fold line 150 joins the flap portion

138 and to an elongate flap portion 156. A fold line 151 joins the flap portion 132 to the elongate flap portion 156. A fold line 152 joins the flap portion 146 to the elongate flap portion 156.

5 The elongate flap portion 156 has a slot 160 adjacent the fold line 150 and in lateral alignment with the slots 140 of the flap portion 138. The flap portion 156 also has a slot 164 adjacent the fold line 152 and in lateral alignment with the slots 148 of the flap portion
10 146. The flap portion 156 also has a slot 170 spaced from the slot 160 and angular with respect thereto. The flap portion 156 also has a slot 174 spaced from the slot 164 and angular with respect thereto.

 The flap portions 138, 146 and 156 are moved
15 with respect to the connection flap portion 132, as illustrated in FIG. 13. With the portions 132, 138, and 146 horizontal, the elongate flap portion is moved upwardly about the fold lines 150, 151, and 152. Then, while the flap portion 146 is maintained horizontal, the flap
20 portion 146 is moved angularly to a position immediately above the connection flap portion 132. With the flap portion 138 maintained horizontal, the flap portion 138 is moved angularly to a position immediately above the flap portion 146. Thus, the slots 140 of the flap portion
25 138, and the slots 148 of the flap portion 146, and the slots 134 of the connection flap portion 132 are in vertical alignment. Thus, the flap portions 132, 138, and 146 become a support section, and the flap portion 156 becomes an enclosure section, as shown in FIG. 13.

30 Then, as shown in FIG. 13, a securing member, such as a strap 180, is inserted through the slot 170 of the flap portion 156 and then along the inner surface of the flap portion 156 and then outwardly through the slot 160 of the flap portion 156. Then the strap 180
35 is extended around the edges of the flap portions 138, 146 and 132. Then the strap 180 is extended around the

edge of the connection part 122 of the attachment portion 116. Then the strap 180 is brought upwardly through one of the slots 126 of the attachment portion 116, then through one of the slots 134 of the flap portion 132, 5 then through one of the slots 148 of the flap portion 146, then through one of the slots 140 of the flap portion 138.

Then the strap 180 is extended across the upper surface of the flap portion 138 and then downwardly through 10 one of the slots 140 of the flap portion 138. Then, the strap 180 is inserted through one of the slots 148 of the flap portion 146, then through one of the slots 134 of the flap portion 132. Then the strap 180 is extended along the exterior surface of the flap portion 15 156 and then through the slot 164 and then along the interior surface of the flap portion 156 and then outwardly through the slot 174. Thus, the heel section 130 is attached to the connection part 122 of the attachment portion 116.

20 A toe section 200 is shown in FIGS. 13, 14 and 15. The toe section 200 has a flap portion 204 and a flap portion 206, which are separated by a flap portion 210. The flap portion 204 has slots 220 and 222. The flap portion 206 has slots 228 and 230. The flap portion 25 210 has a plurality of apertures 240.

As shown in FIGS. 13 and 15, a securing member, in the form of a strap 250, is inserted through the slot 230 of the flap portion 206, then along the interior surface of the flap 206 and then outwardly through the 30 slot 228 of the flap portion 200. Then the strap 250 is extended along the lower surface of the flap portion 210 and then along the exterior surface of the flap portion 204 and through the slot 222 of the flap portion 204. Then the strap 250 is extended along the interior surface 35 of the flap portion 204. Then the strap 250 is inserted through the slot 220 of the flap portion 204. Thus, the strap 250 is attached to the toe section 200.

Then fastener members, such as screws 300, are inserted through the apertures 240 of the flap portion 210 and are then inserted through selected apertures 124 in the elongate portion 116. The screws 300 are
5 then inserted into holes 346 of a ski 350, as illustrated in FIG. 13. Thus, the ski binding structure of FIGS. 11, 12, 13, 14 and 15 is attached to the ski 350.

The toe section 200 can be attached to any desired part of the elongate portion 116 by selecting
10 a desired set of aperture 124 of the attachment portion 116. Thus, the ski binding structure of FIGS. 11-15 is adjustable to accomodate a large boot or a small boot.

Although the preferred embodiment of the ski binding structure and method of this invention have
15 been described, it will be understood that within the purview of this invention various changes may be made in the form, details, proportion and arrangement of parts, the combination thereof, and the methods involved, which generally stated consist in a structure and/or method
20 within the scope of the appended claims.

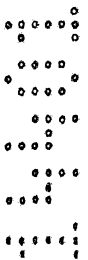

The claims defining the invention are as follows:

1. Ski binding structure for attachment to a snow ski, the ski binding structure being adapted to receive a ski boot or the like, comprising:

a receptacle member adapted to receive at least
5 a portion of a ski boot or the like including a single piece of material having a plurality of portions which are folded one with respect to the other, there being a bottom portion, a pair of side portions and an enclosure portion, the side portions being separated from the bottom
10 portion by cut lines, the enclosure portion being joined to the bottom portion and to the side portions by fold lines, the side portions being positioned one upon the other and positioned upon the bottom portion, the enclosure portion extending upwardly from the bottom portion and
15 from the side portions, the enclosure portion encompassing at least part of the side portions and the bottom portion, whereby a receptacle is formed to receive a part of a ski ~~boot~~ ^{boot} or the like, as a part of the ski ~~boot~~ ^{boot} is positioned upon one of the side portions and above the side
20 portions and above the bottom portion, and as a part of the ski boot is partially encompassed by the enclosure portion, and means for attachment of at least one of the portions to a ski.

2. The ski binding structure of Claim 1 in which the bottom portion is elongate and extends from the other portions, the bottom portion being provided with a series of apertures for adjustable attachment
5 to a ski.



3. The ski binding structure of Claim 1 in which the receptacle which is formed is adapted to receive a heel part of a ski boot or the like and in which the bottom portion is elongate and provided with a plurality of connection portion, and in which the ski binding structure includes a toe section, means for adjustably attaching the toe section to any one of the connection portions of the bottom portion, and means for attaching the bottom portion and the toe section to a ski.

4. The ski binding structure of Claim 1 which includes an elongate attachment member having a part positioned upon the bottom portion, the elongate attachment member being provided with a slot therethrough, the bottom portion being provided with a slot therethrough, each of the side portions being provided with a slot therethrough, a strap extending through the slots in the attachment member and in the bottom portion and in the side portions, the strap thus attaching the elongate attachment member to the side portions and to the bottom portion.

5. Ski binding structure for attachment to a snow ski and for receiving a ski boot or the like comprising:

a receptacle member adapted to receive a portion
5 of a ski boot or the like including a single piece of material having a plurality of portions which are folded one with respect to the others, there being a bottom portion, a pair of side portions and an enclosure portion, the side portions being positioned one upon the other
10 and positioned above the bottom portion, the side portions and the bottom portion being adapted to be generally horizontal, the enclosure portion encompassing a part of the side portions and the bottom portion and extending upwardly therefrom, a receptacle thus being formed
15 to receive a part of a ski boot or the like as a part of the ski boot rests upon a side portion and is above the side portions and above a part of the bottom portion and as a part of the ski ~~boot~~^{boot} is partially encompassed by the enclosure portion, and attachment means for attach-
20 ment of the bottom portion to a ski.

6. The ski binding structure of Claim 5 in which the attachment means includes an elongate attachment member, and means attaching the elongate attachment member to the bottom portion of the receptacle member.

7. The ski binding structure of Claim 5 in which the attachment means includes an elongate attachment member provided with a slot therein, and in which the bottom portion is provided with a slot therein,
5 and strap means extending through the slots and attaching the elongate attachment member to the bottom portion of the receptacle member.

8. The ski binding structure of Claim 5 wherein the bottom portion includes a series of connection portions, and means for attachment of any one of the connection portions to a ski.

9. ^A ~~The method of producing ski binding structure~~ for attachment to a ski and for receiving a ski boot or the like, comprising:

forming a single sheet of material into a plurality of portions, including an attachment portion, a
5 ~~bottom portion, a~~ pair of side portions including a first side portion and a second side portion, forming a cut line between the attachment portion and the first side portion, forming a cut line between the attachment portion and the second
10 side portion, forming an enclosure portion, forming a fold line between the enclosure portion and the first side portion and forming a fold line between the enclosure portion and the bottom portion and forming a fold line between the enclosure portion and the second side portion,
15 and forming a fold line between the enclosure portion and the attachment portion,

moving the side portions to positions one upon the other and upon the bottom portion, folding the enclosure portion to a position which partially encompasses
20 the attachment portion and the side portions, the formation of the side portions and the attachment portion and the enclosure portion thus forming a receptacle for a portion of a ski boot or the like.

10. The method of Claim 9 which includes forming the attachment portion into an elongate configuration, and which includes forming a second sheet of material into a toe receiving configuration, followed by attaching
5 the second sheet of material to a part of the attachment portion, followed by attaching the elongate attachment portion and the second sheet of material to a ski.



11. The method of Claim 9 which includes forming a slot in each of the portions, followed by inserting a strap through the slot in each of the portions, whereby portions are secured together for securing a part portion
5 of a boot in engagement with the enclosure portion.

12. ^A ~~The method of producing a ski binding.~~
structure for attachment to a ski and for receiving a boot or the like comprising:

forming a flat sheet of material into an attachment portion, a pair of side portions, and an enclosure portion, separating the side portions from the attachment portions, with the enclosure portion attached to the attachment portion,
5

followed by moving the side portions to positions one upon the other and upon the attachment portion, whereby the side portions cover the attachment portion, and
10 folding the enclosure portion with respect to the attachment portion and to a position which partially encompasses the attachment portion and the side portions to form
15 a receptacle which is adapted to receive a portion of a boot or the like.

13. The method of Claim 12 which includes forming a slot in each of the portions, followed by inserting a strap through the slot in each of the portions for retaining the portions in formation and for maintaining a portion of a boot in contact with the enclosure
5 portion.

14. The method of Claim 12 which includes forming the attachment portion into an elongate configuration for attachment of a part of the attachment portion to a ski, in which the part of the attachment portion
5 is spaced from the enclosure portion.



15. The method of Claim 12 which includes forming the attachment portion into an elongate configuration for attachment of the attachment portion to a ski, forming an elongate strip of material into a generally U-shape element, to receive a portion of a boot or the like, followed by attaching the elongate strip of material to the elongate attachment portion and to a ski.

16. The method of Claim 12 which includes forming an elongate strip of material, followed by attaching the elongate strip of material to the attachment portion of the folded sheet of material.

17. The method of Claim 12 which includes attaching a strap to each of the portions to retain the portions in receptacle formation.

18. The method of Claim 12 which includes forming an elongate strip of material, followed by attaching a strap to each of the portions of the folded sheet of material and attaching the strap to the elongate strip of material for securing the folded sheet of material to the elongate strip of material and for retaining a portion of a boot which is enclosed by the enclosure portion.

19. The method of Claim 12 which includes forming an elongate strip of material, followed by inserting a strap through each of the portions of the folded sheet of material and through the elongate strip of material for attaching the receptacle formation to the elongate strip of material and for retaining a portion of a boot in engagement with the enclosure portion, forming a toe member, followed by attaching the toe member to the elongate strip of material and to a ski.

20. The method of Claim 12 which includes forming an elongate attachment member, attaching the elongate attachment member to the attachment portion which is covered by the side portions.

5 21. Ski binding structure for retaining footwear of a skier comprising a sheet of material provided with an attachment portion, the attachment portion including means for attachment to a ski, a pair of side portions, and an enclosure portion, the side portions and the attachment portion being adapted to be substantially horizontal, the side portions being positioned one upon the other and above the attachment portion, the enclosure portion extending upwardly from the attachment portion and from the side portions, the enclosure portion partially encompassing the side portions and the attachment portion, the attachment portion and the side portions and the enclosure portion thus forming a receptacle to receive footwear as the footwear is positioned above the side portions and the attachment portion and as a part of the footwear is partially encompassed by the enclosure portion, and means for attaching the attachment portion to a ski.

10

15

22. The ski binding structure of Claim 21 in which the attachment portion is elongate in configuration, and in which the attachment portion includes means along the length thereof for adjustable attachment of the attachment portion to a ski.

5

23. The ski binding structure of Claim 21 in which the receptacle is adapted to receive the heel of a ski boot, and in which the attachment portion is elongate in configuration, and in which the attachment
5 portion is provided with means along the length thereof for adjustable attachment to a ski, and in which the ski binding structure includes a ski boot toe receptacle member, the ski boot toe receptacle member being posi-
10 tioned upon the elongate attachment portion and attached to the elongate attachment portion.

24. The ski binding structure of Claim 21 which includes a toe section, means attaching the toe section to the attachment portion, and means for attaching the toe section and the attachment portion to a ski.

25. The ski binding structure of Claim 21 in which the attachment portion is elongate in configuration, and in which the attachment portion includes a plurality of attachment sections and means for attach-
5 ment of any one of the attachment sections to a ski boot.

26. The simplified adjustable ski binding structure substantially as hereinbefore described and as shown in the accompanying drawings.

~~DATED this EIGHTH day of APRIL, 1988~~

~~James E. Klosterman~~

~~Patent Attorneys for the Applicant
SPRUISON & FERGUSON~~



27. ^A ~~The method of producing ski binding structure~~

for attachment to a snow ski and for receiving a ski boot or the like, which is provided with a heel portion and a toe portion, comprising:

5 forming a single sheet of foldable material into a plurality of portions, including an attachment portion and an enclosure portion,

10 folding the enclosure portion to a position which is angular with respect to the attachment portion and positioning the enclosure portion to partially encompass the attachment portion, with the attachment portion being substantially horizontal and the enclosure portion extending upwardly from the attachment portion, whereby the attachment portion and the enclosure portion form
15 a receptacle for a heel portion of a ski boot or the like.

28. The method of Claim 27 which includes forming the attachment portion into an elongate configuration, and which includes forming a second sheet of foldable material into a generally U-shape configuration for receiving a toe portion of a ski boot or the like, followed by attaching the elongate attachment portion and the second sheet of foldable material to a ski.



29. The method of Claim 27 which includes forming a slot in each of the portions, followed by inserting a strap through the slot in each of the portions, whereby the portions are secured together for receiving
5 a heel portion of a boot as the heel portion is partially encompassed by the enclosure portion, and as the strap is positioned to encompass a portion of the boot to secure the enclosure portion in encompassing relationship with respect to said portion of the boot.

30. Ski binding structure for attachment to a snow ski, the ski binding structure being adapted to receive a ski boot or the like, comprising:

a receptacle member adapted to receive at least
5 a portion of a ski boot or the like including a single piece of foldable material having a plurality of portions which are folded one with respect to the other, there being a bottom portion and an enclosure portion, the bottom portion being adapted to be substantially horizontal, the enclosure portion extending upwardly from
10 the bottom portion as the enclosure portion encompasses at least a part of the bottom portion, means for maintaining the enclosure portion in an upwardly extending position with respect to the bottom portion, whereby a receptacle is formed to receive a part of a ski boot or
15 the like, as a part of the ski boot is positioned upon the bottom portion and is partially encompassed by the enclosure portion, and means for attachment of the bottom portion to a ski.



31. The ski binding structure of Claim 30 for receiving a ski boot having a heel portion and a toe portion, in which the receptacle which is formed by the bottom portion and the enclosure portion is adapted
5 to receive a heel portion of a ski boot or the like and in which the bottom portion is elongate and is provided with a plurality of connection portions, and in which the ski binding structure includes a toe section, means for adjustably attaching the toe section to any one of
10 the connection portions of the bottom portion, and means for attaching the bottom portion and the toe section to a ski.

32. The ski binding structure of Claim 30 which includes an elongate attachment member having a part positioned adjacent the bottom portion, the elongate attachment member being provided with a slot therethrough,
5 the bottom portion being provided with a slot therethrough, a strap extending through the slots in the attachment member and in the bottom portion, whereby the strap attaches the elongate attachment member to the bottom portion.

33. The ski binding structure of Claim 30 which includes an elongate attachment member having a part positioned adjacent the bottom portion, and means for attachment of the elongate attachment member to the
5 bottom portion.



DATED this NINETEENTH day of OCTOBER 1988
James E Klosterman

Patent Attorneys for the Applicant
SPRUSON & FERGUSON

RECEIVED
OCT 20 1988
PATENT OFFICE

RECEIVED
OCT 20 1988
PATENT OFFICE



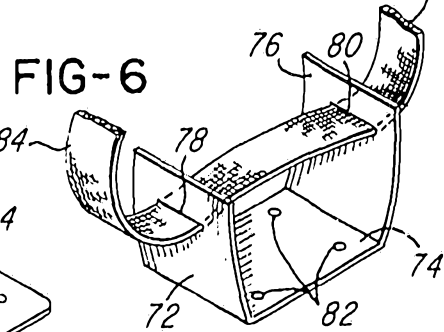
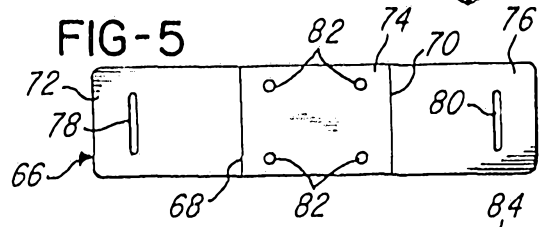
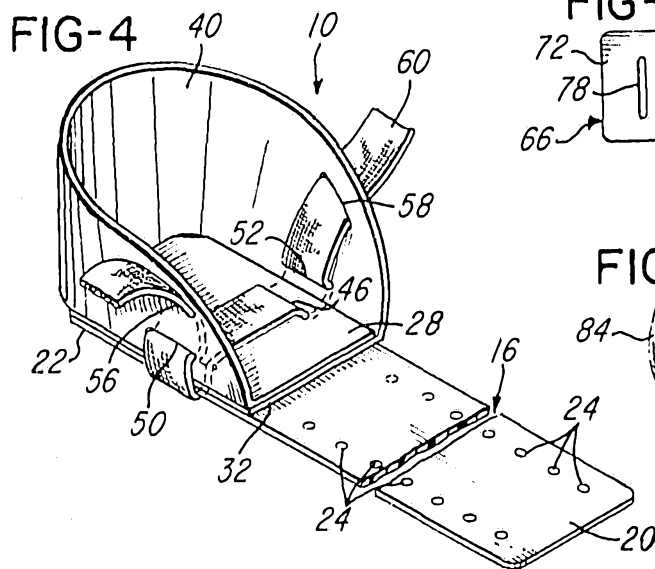
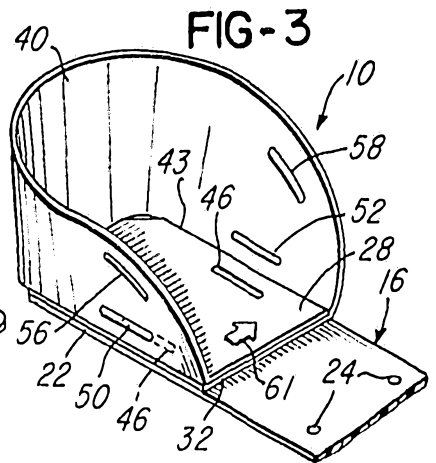
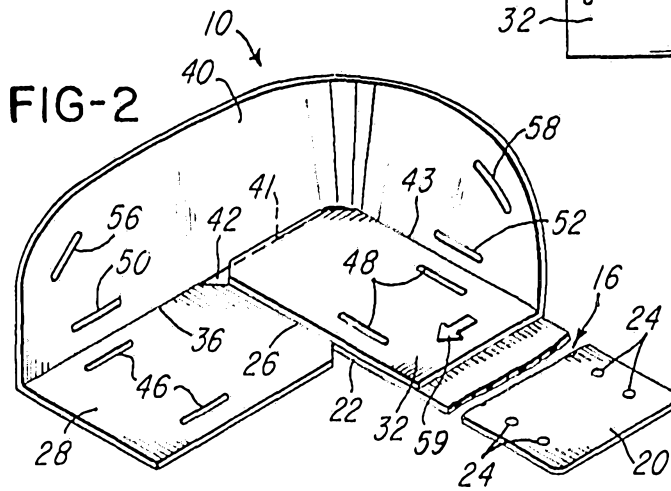
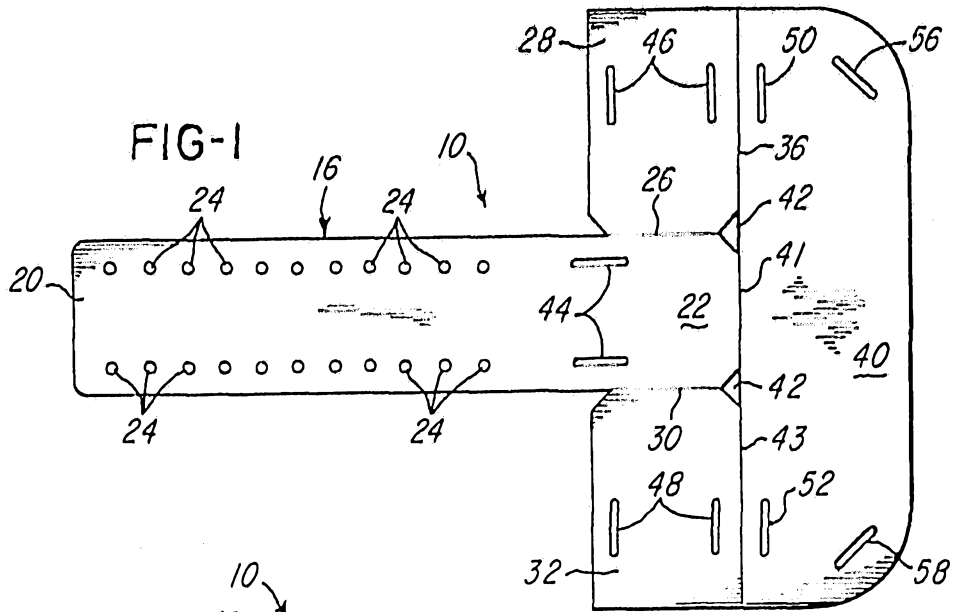

FIG-7

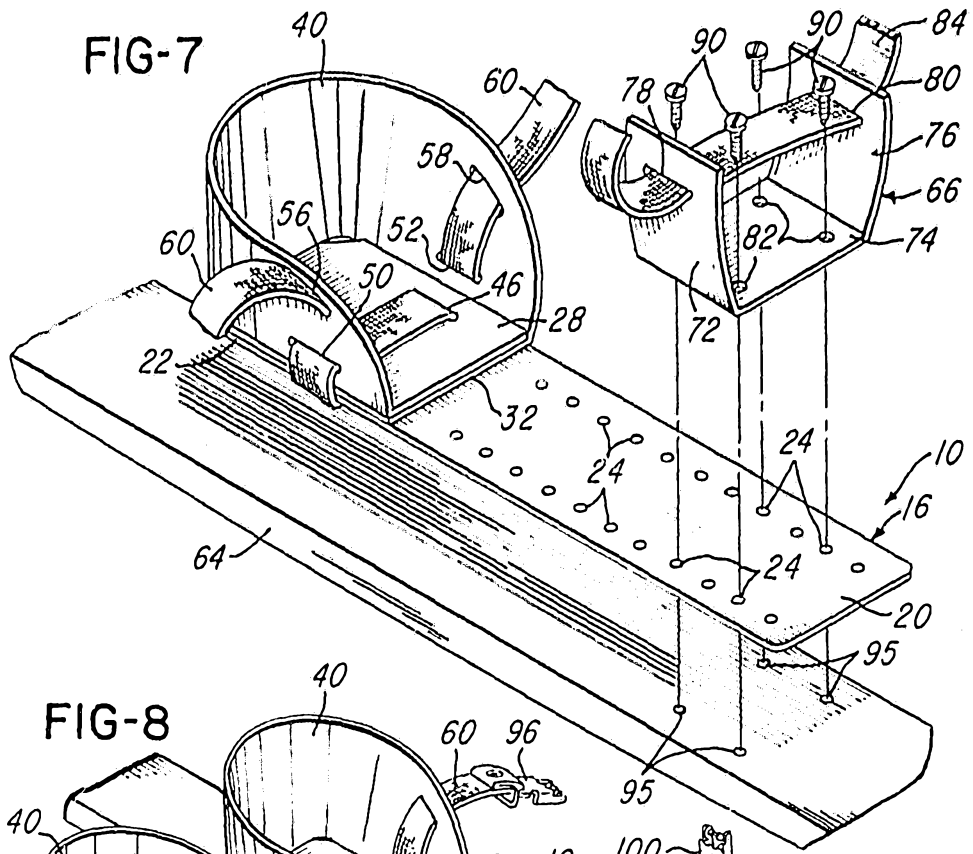

FIG-8

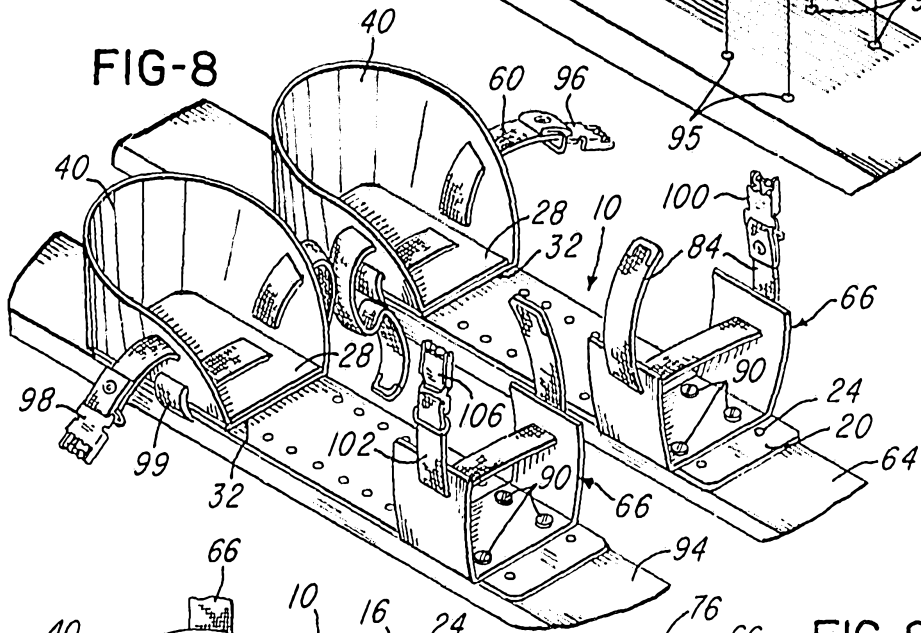

FIG-9

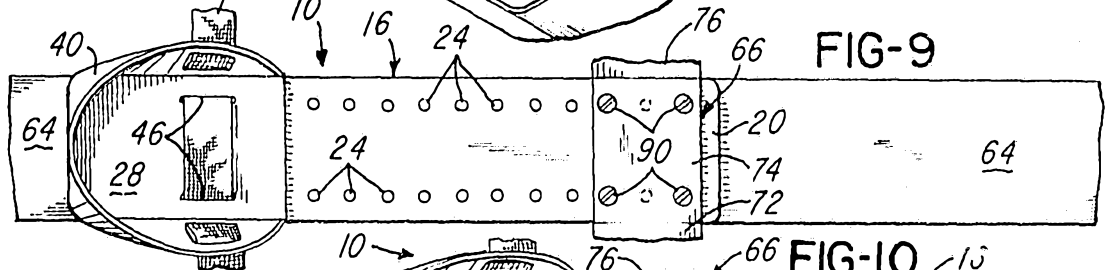

FIG-10

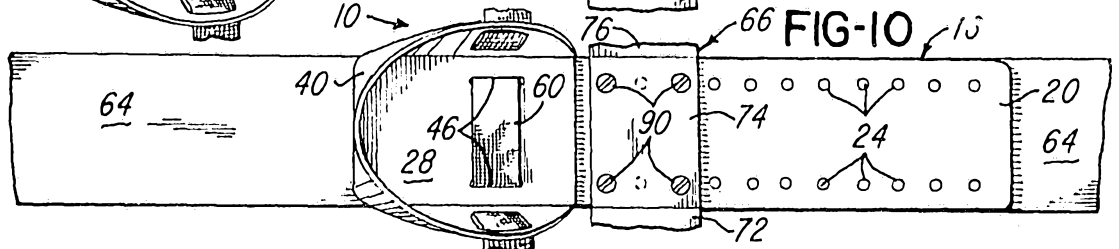

FIG-11

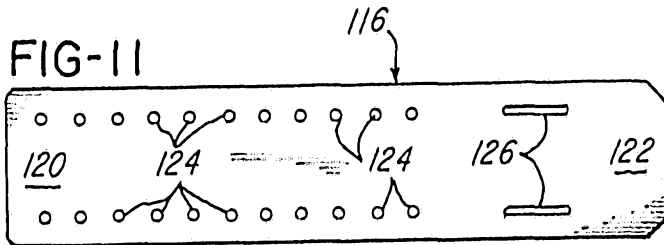

FIG-12

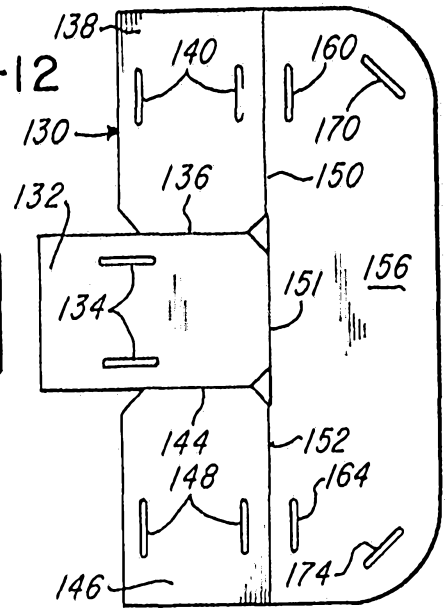

FIG-13

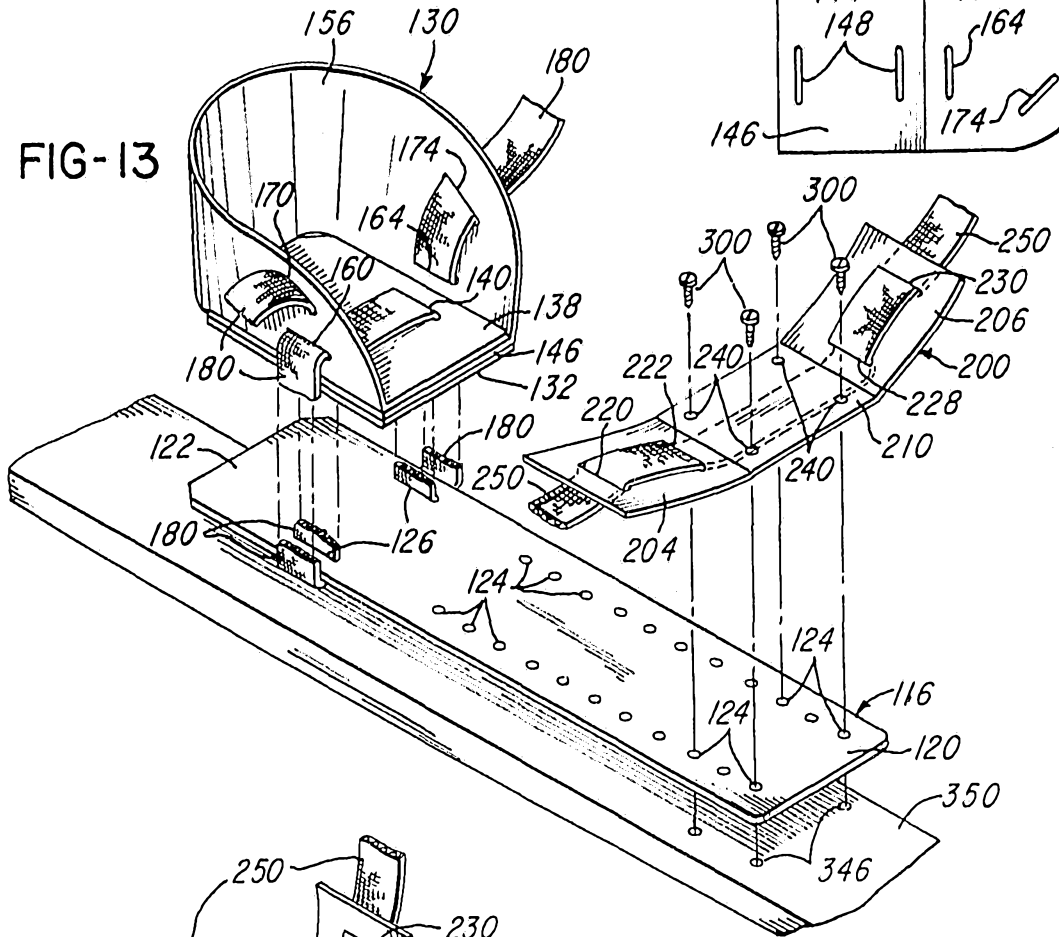

FIG-15

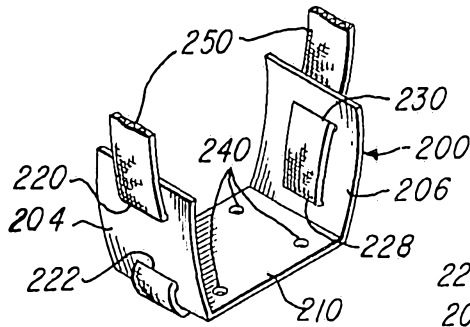

FIG-14

